

ITEM #	PART #	QTY	DESCRIPTION
1	MAJ-10-25	1	INSERT, RECEPTACLE, 6-COND
2	MAJ-10-67	1	HOUSING JACK
3	MAP-57-01	1	STRAIN RELIEF
4	MAP-50-03	1	WASHER, RUBBER
5	MAP-50-24	1	NUT ADAPTER, ϕ .250
6	AJ-117BR-9	1	BUSHING, ϕ .250
7	AJ-117BR-10	1	WASHER, ϕ .250
8	AJ-117BR-15	1	SPRING, ϕ .250
9	AJ-117BR-11	1	STUD, SHELL ϕ .250

B MAJ-57-30

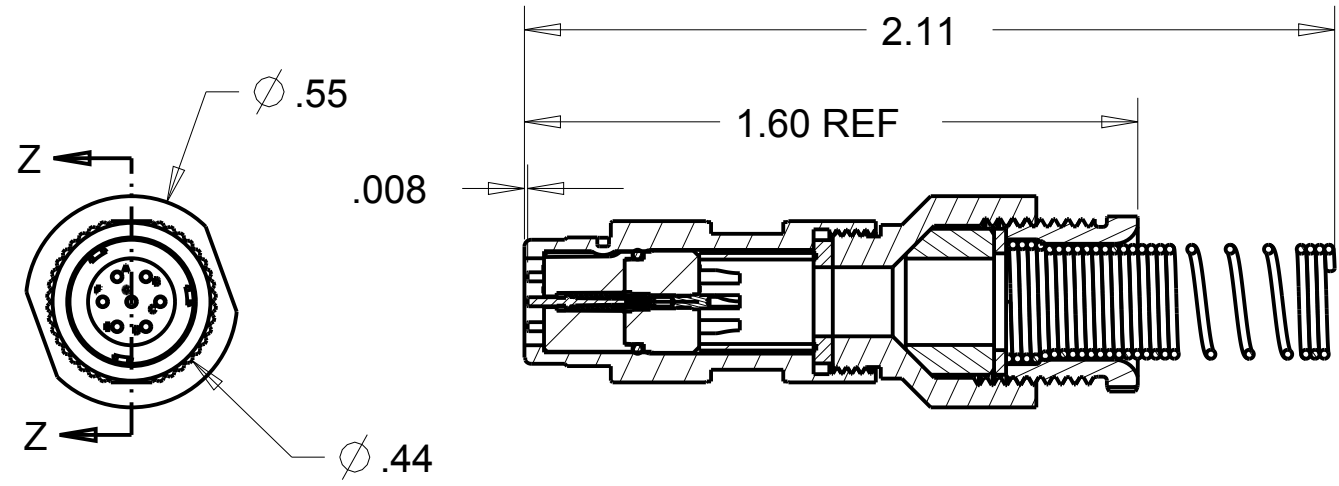
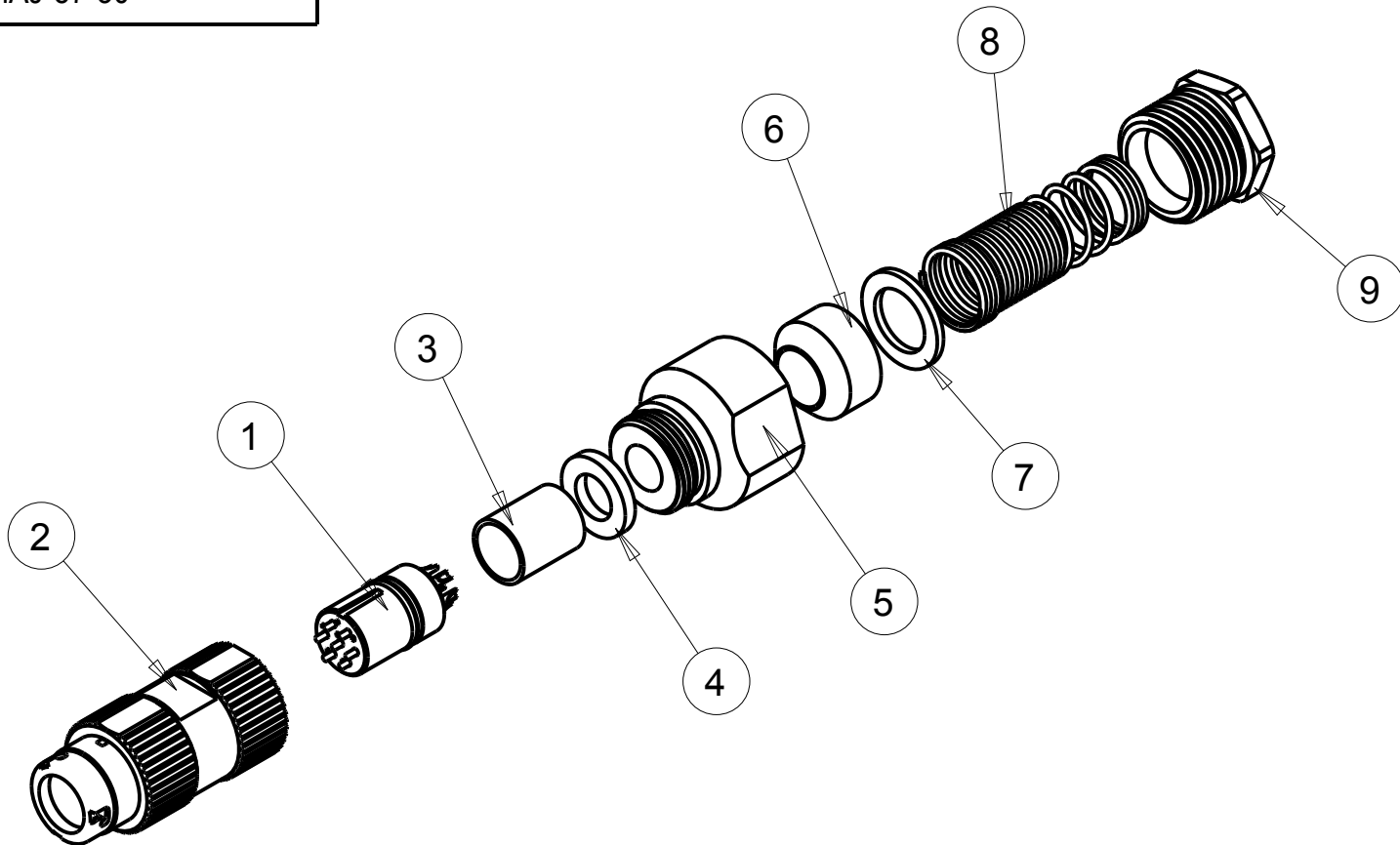

SECTION Z-Z

THIS DOCUMENT CONTAINS PROPRIETARY INFORMATION OF NEXUS, INCORPORATED AND SUCH INFORMATION MAY NOT BE DISCLOSED TO OTHERS FOR ANY PURPOSE OR USED FOR ANY PURPOSE WITHOUT THE WRITTEN CONSENT OF NEXUS.

LET.	REVISION	CN #	DATE	CHK.
C	CHG: ,AP-60-06 TO MAP-57-01	152	1/24 2013	HR
B	CHG MAP-50-05 TO MAP-60-06	146	11/8 2012	HR
A	NEW RELEASE		9/28 2011	HR

DWN.BY	HR	DATE	9/28/11
CHECKED BY		DATE	
APPR.BY		DATE	

MATERIAL	
FINISH	
WEIGHT	SCALE = 1.00 :1
TITLE	
7- COND JACK ϕ .250 CABLE	
DO NOT SCALE DWG.	SHEET 1 OF 1

NEXUS STAMFORD, CONN	
B	MAJ-57-30