

GaAs MMIC SOT26 SPDT SWITCH, DC- 3 GHz

Typical Applications

The HMC197BE is ideal for:

- MMDS & WirelessLAN
- PCMCIA Wireless Cards
- Portable Wireless

Functional Diagram

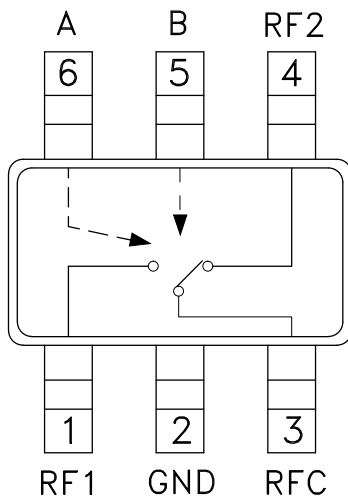

Features

- Low Insertion Loss: 0.4 dB
- Ultra Small Package: SOT26
- Input IP3: +59 dBm
- Positive Control: 0/+3V @ 3 μ A

General Description

The HMC197BE is a low-cost SPDT switch in a 6-lead SOT26 plastic package for use in general switching applications which require very low insertion loss and very small size. The device can control signals from DC to 3 GHz and is especially suited for 900 MHz, 1.8 - 2.2 GHz, and 2.4 GHz ISM applications with less than 1 dB loss. The design provides exceptional insertion loss performance, ideal for filter and receiver switching. RF1 and RF2 are reflective shorts when "Off". The two control voltages require a minimal amount of DC current and offer compatibility with most CMOS & TTL logic families. See HMC221BE for same performance in an alternate SOT26 pin-out.

Electrical Specifications, $T_A = +25^\circ C$, $V_{ctl} = 0/+3$ to $+8$ Vdc, 50 Ohm System

Parameter	Frequency	Min.	Typ.	Max.	Units
Insertion Loss	DC - 1.0 GHz		0.4	0.7	dB
	DC - 2.0 GHz		0.4	0.8	dB
	DC - 2.5 GHz		0.4	0.9	dB
	DC - 3.0 GHz		0.5	1.1	dB
Isolation	DC - 1.0 GHz	24	30		dB
	DC - 2.0 GHz	24	34		dB
	DC - 2.5 GHz	18	29		dB
	DC - 3.0 GHz	14	24		dB
Return Loss	DC - 1.0 GHz	20	35		dB
	DC - 2.0 GHz	16	31		dB
	DC - 2.5 GHz	14	28		dB
	DC - 3.0 GHz	10	24		dB
Input Power for 1dB Compression ($V_{ctl} = 0/+5V$)	0.5 - 1.0 GHz	25	30		dBm
	0.5 - 3.0 GHz	23	29		dBm
Input Third Order Intercept ($V_{ctl} = 0/+5V$) (Two-tone Input Power = +10 dBm Each Tone)	0.5 - 1.0 GHz	40	59		dBm
	0.5 - 3.0 GHz	38	55		dBm
Switching Characteristics	DC - 3.0 GHz				
		tRISE, tFALL (10/90% RF) tON, tOFF (50% CTL to 10/90% RF)		3 10	ns ns

GaAs MMIC SOT26 SPDT SWITCH, DC- 3 GHz

Insertion Loss

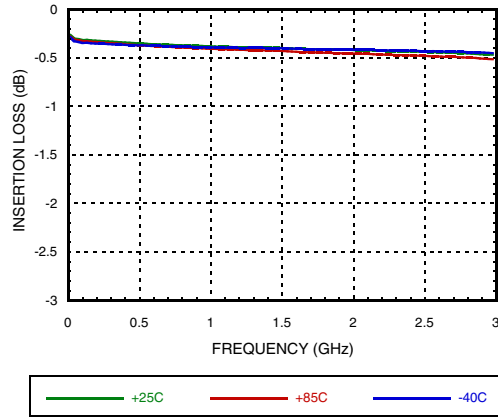

Isolation

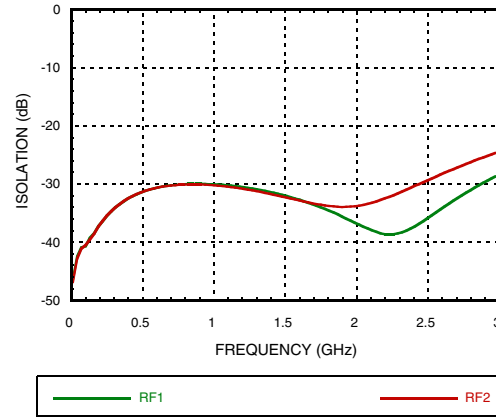

Return Loss

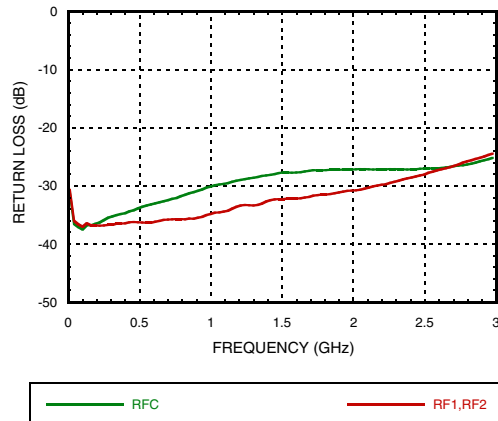

Input 0.1 and 1.0 dB Compression vs. Control Voltage

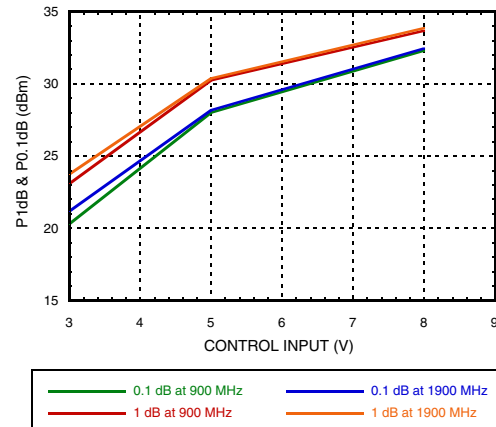

Input Third Order Intercept Point vs. Control Voltage

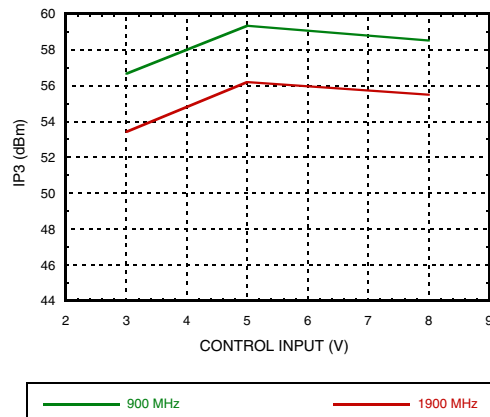

Distortion vs. Control Voltage

Control Input (Vdc)	Third Order Intercept (dBm) +10 dBm Each Tone	
	900 MHz	1900 MHz
+3	57	53
+5	59	56
+8	58	55

Truth Table

*Control Input Voltage Tolerances are ± 0.2 Vdc.

Control Input*		Control Current		Signal Path State	
A (Vdc)	B (Vdc)	Ia (µA)	Ib (µA)	RF to RF1	RF to RF2
0	+3	-0.5	0.5	ON	OFF
+3	0	0.5	-0.5	OFF	ON
0	+5	-1.1	1.1	ON	OFF
+5	0	1.1	-1.1	OFF	ON
0	+8	-8	8	ON	OFF
+8	0	8	-8	OFF	ON

GaAs MMIC SOT26 SPDT SWITCH, DC- 3 GHz

Compression vs. Control Voltage

Control Input (Vdc)	Carrier at 900 MHz		Carrier at 1900 MHz	
	Input Power for 0.1 dB Compression (dBm)	Input Power for 1.0 dB Compression (dBm)	Input Power for 0.1 dB Compression (dBm)	Input Power for 1.0 dB Compression (dBm)
+3	21	24	21	24
+5	28	30	27	30
+8	32	34	32	34

Caution: Do not operate in 1dB compression at power levels above +31 dBm (Vctl = +5 Vdc) and do not "hot switch" power levels greater than +20 dBm (Vctl = +5Vdc). DC blocks are required at ports RFC, RF1 and RF2.

Absolute Maximum Ratings

Control Voltage Range (A & B)	-0.2 to +12 Vdc
Storage Temperature	-65 to +150 °C
Operating Temperature	-40 to +85 °C
ESD Sensitivity (HBM)	Class 1A



**ELECTROSTATIC SENSITIVE DEVICE
OBSERVE HANDLING PRECAUTIONS**

Outline Drawing

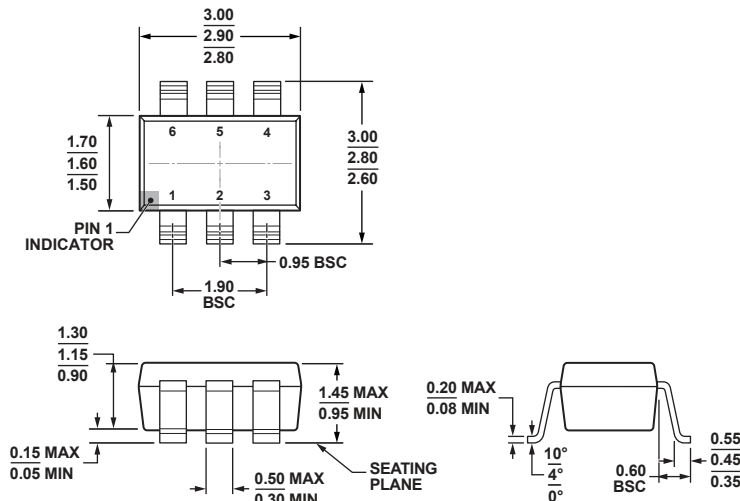

COMPLIANT TO JEDEC STANDARDS MO-178-AB

6-Lead Small Outline Transistor Package [SOT-23] (RJ-6)

Dimensions shown in millimeters.

12-16-2008-A

Package Information

Part Number	Package Body Material	Lead Finish	MSL Rating	Package Marking ^[3]
HMC197BE	RoHS-compliant Low Stress Injection Molded Plastic	100% matte Sn	MSL1 ^[1]	197BE XXXX

[1] Max peak reflow temperature of 260 °C

[2] 4-Digit lot number XXXX

GaAs MMIC SOT26 SPDT SWITCH, DC- 3 GHz

Typical Application Circuit

Notes:

1. Set logic gate and switch Vdd = +3V to +5V and use HCT series logic to provide a TTL driver interface.
2. Control inputs A/B can be driven directly with CMOS logic (HC) with Vdd of 5 to 8 Volts applied to the CMOS logic gates.
3. DC Blocking capacitors are required for each RF port as shown. Capacitor value determines lowest frequency of operation.
4. Highest RF signal power capability is achieved with Vdd = +8V and A/B set to 0/+8V.

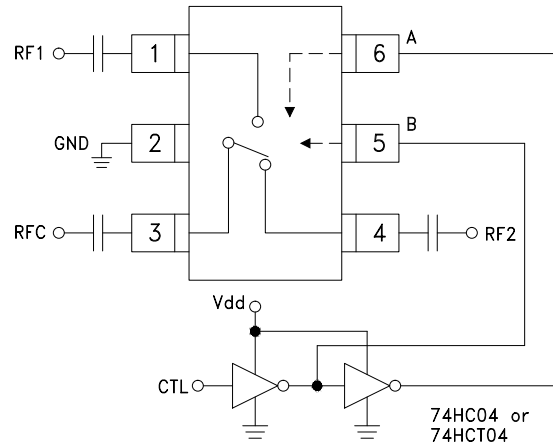

Evaluation Circuit Board

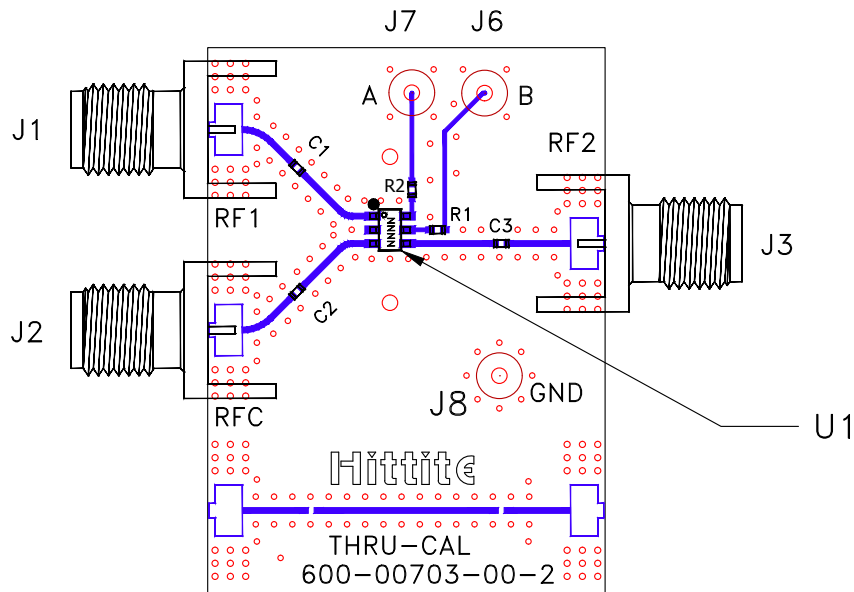

List of Materials for Evaluation PCB EVAL01-HMC197BE^[1]

Item	Description
J1 - J3	PCB Mount SMA RF Connector
J6 - J8	DC Pin
C1 - C3	330 pF Capacitor, 0603 Pkg.
R1, R2	1 kOhm Resistor, 0402 Pkg.
U1	HMC197BE SPDT Switch
PCB [2]	600-00703-00 Evaluation PCB

[1] Reference this number when ordering complete evaluation PCB

[2] Circuit Board Material: Rogers 4350

The circuit board used in the final application should be generated with proper RF circuit design techniques. Signal lines at the RF port should have 50 Ohm impedance and the package ground leads and package bottom should be connected directly to the ground plane similar to that shown above. The evaluation circuit board shown above is available from Analog Devices Inc. upon request.