

Click [here](#) for production status of specific part numbers.

MAX17572

4.5V–60V, 1A, High-Efficiency, Synchronous Step-Down DC-DC Converter with Internal Compensation

General Description

The MAX17572 high-efficiency, high-voltage, synchronous step-down DC-DC converter with integrated MOSFETs operates over a 4.5V to 60V input. The converter can deliver up to 1A and generates output voltages from 0.9V up to $0.9 \times V_{IN}$. The feedback (FB) voltage is accurate to within $\pm 1.2\%$ over -40°C to $+125^{\circ}\text{C}$. The MAX17572 uses peak current-mode control.

The device is available in a 12-pin (3mm x 3mm) TDFN package. Simulation models are available.

Applications

- Industrial Control Power Supplies
- General-Purpose Point-of-Load
- Distributed Supply Regulation
- Base Station Power Supplies
- Wall Transformer Regulation
- High-Voltage, Single-Board Systems

Benefits and Features

- Reduces External Components and Total Cost
 - No Schottky-Synchronous Operation
 - Internal Compensation for Any Output Voltage
 - All-Ceramic Capacitors, Compact Layout
- Reduces Number of DC-DC Regulators to Stock
 - Wide 4.5V to 60V Input
 - Adjustable 0.9V to $0.9 \times V_{IN}$ Output
 - Continuous 1A Current Over Temperature
 - 400kHz to 2.2MHz Adjustable Switching Frequency with External Synchronization
- Reduces Power Dissipation
 - Peak Efficiency > 92%
 - Auxiliary Bootstrap LDO for Improved Efficiency
 - 4.65 μA Shutdown Current
- Operates Reliably in Adverse Industrial Environments
 - Hiccup Mode Overload Protection
 - Adjustable Soft-Start
 - Built-In Output-Voltage Monitoring with $\overline{\text{RESET}}$
 - Programmable EN/UVLO Threshold
 - Monotonic Startup into Prebiased Load
 - Overtemperature Protection
 - High Industrial -40°C to $+125^{\circ}\text{C}$ Ambient Operating Temperature Range/ -40°C to $+150^{\circ}\text{C}$ Junction Temperature Range

[Ordering Information](#) appears at end of data sheet.

Absolute Maximum Ratings

V_{IN} to PGND	-0.3V to +65V	V_{CC} to GND	-0.3V to +6.5V
EN/UVLO to GND	-0.3V to $V_{IN} + 0.3V$	LX Total RMS Current	$\pm 1.6A$
EXTV _{CC} to GND	-0.3V to +26V	Continuous Power Dissipation ($T_A = +70^\circ C$)	
BST to PGND	-0.3V to +70V	(derate 24.4mW/ $^\circ C$ above +70 $^\circ C$) (Multilayer board) ..	1951mW
LX to PGND	-0.3V to ($V_{IN} + 0.3$)V	Output Short-Circuit Duration	Continuous
BST to LX	-0.3V to +6.5V	Junction Temperature	+150 $^\circ C$
BST to V_{CC}	-0.3V to +65V	Storage Temperature Range	-65 $^\circ C$ to +160 $^\circ C$
RESET, SS, RT/SYNC to GND	-0.3V to +6.5V	Lead Temperature (soldering, 10s)	+300 $^\circ C$
PGND to GND	-0.3V to +0.3V	Soldering Temperature (reflow)	+260 $^\circ C$
FB to GND	-0.3V to +1.5V		

Stresses beyond those listed under "Absolute Maximum Ratings" may cause permanent damage to the device. These are stress ratings only, and functional operation of the device at these or any other conditions beyond those indicated in the operational sections of the specifications is not implied. Exposure to absolute maximum rating conditions for extended periods may affect device reliability. Junction temperature greater than +125 $^\circ C$ degrades operating lifetimes.

Package Information

PACKAGE TYPE: 12 TDFN	
Package Code	TD1233+1C
Outline Number	21-0664
Land Pattern Number	90-0397
THERMAL RESISTANCE, FOUR-LAYER BOARD	
Junction to Ambient (θ_{JA})	41 $^\circ C/W$
Junction to Case (θ_{JC})	8.5 $^\circ C/W$

For the latest package outline information and land patterns (footprints), go to www.maximintegrated.com/packages. Note that a "+", "#", or "-" in the package code indicates RoHS status only. Package drawings may show a different suffix character, but the drawing pertains to the package regardless of RoHS status.

Package thermal resistances were obtained using the method described in JEDEC specification JESD51-7, using a four-layer board. For detailed information on package thermal considerations, refer to www.maximintegrated.com/thermal-tutorial.

Electrical Characteristics

($V_{IN} = V_{EN/UVLO} = 24V$, $R_{RT} = 40.2k$, $C_{VCC} = 2.2\mu F$, $V_{PGND} = V_{GND} = EXT_{VCC} = 0$, $LX = SS = \overline{RESET} = OPEN$, $V_{BST} \text{ to } V_{LX} = 5V$, $V_{FB} = 1V$, $T_A = -40^\circ C$ to $125^\circ C$, unless otherwise noted. Typical values are at $T_A = +25^\circ C$. All voltages are referenced to GND, unless otherwise noted.) (Note 1)

PARAMETER	SYMBOL	CONDITIONS	MIN	TYP	MAX	UNITS
INPUT SUPPLY (V_{IN})						
Input Voltage Range	V_{IN}		4.5		60	V
Input Shutdown Current	I_{IN-SH}	$V_{EN/UVLO} = 0V$ (shutdown mode)		4.65	7.25	μA
Input Quiescent Current	I_{Q_PWM}	Normal switching mode, $f_{SW} = 500kHz$, $V_{FB} = 0.8V$, $EXT_{VCC} = GND$		5.2		mA
ENABLE/UVLO (EN)						
EN/UVLO Threshold	V_{ENR}	$V_{EN/UVLO}$ rising	1.19	1.215	1.26	V
	V_{ENF}	$V_{EN/UVLO}$ falling	1.068	1.09	1.131	V
EN/UVLO Input Leakage Current	I_{ENLKG}	$V_{EN/UVLO} = 1.25V$, $T_A = 25^\circ C$	-50		+50	nA

Electrical Characteristics (continued)

($V_{IN} = V_{EN/UVLO} = 24V$, $R_{RT} = 40.2k$, $C_{VCC} = 2.2\mu F$, $V_{PGND} = V_{GND} = EXT_{VCC} = 0$, $LX = SS = \overline{RESET} = OPEN$, V_{BST} to $V_{LX} = 5V$, $V_{FB} = 1V$, $T_A = -40^\circ C$ to $125^\circ C$, unless otherwise noted. Typical values are at $T_A = +25^\circ C$. All voltages are referenced to GND, unless otherwise noted.) (Note 1)

PARAMETER	SYMBOL	CONDITIONS	MIN	TYP	MAX	UNITS
V_{CC} LDO						
V _{CC} Output Voltage Range	V _{CC}	$1mA \leq I_{VCC} \leq 15mA$	4.75	5	5.25	V
		$6V \leq V_{IN} \leq 60V$; $I_{VCC} = 1mA$	4.75	5	5.25	V
V _{CC} Current Limit	I _{VCC-MAX}	$V_{CC} = 4.3V$, $V_{IN} = 6.5V$	25	54	100	mA
V _{CC} Dropout	V _{CC-DO}	$V_{IN} = 4.5V$, $I_{VCC} = 15mA$	4.15			V
V _{CC} UVLO	V _{CC-UVR}	Rising	4.05	4.2	4.3	V
	V _{CC-UVF}	Falling	3.65	3.8	3.9	V
EXT LDO						
EXTV _{CC} Switchover Voltage		EXTV _{CC} rising	4.56	4.7	4.84	V
		EXTV _{CC} falling	4.3	4.45	4.6	V
EXTV _{CC} Dropout	EXTV _{CC-DO}	$EXT_{VCC} = 4.75V$, $I_{EXT_{VCC}} = 15mA$			0.3	V
EXTV _{CC} Current Limit	EXT V _{CC} LIM	$V_{CC} = 4.5V$, $EXT_{VCC} = 7V$	26.5	60	100	mA
HIGH-SIDE MOSFET AND LOW-SIDE MOSFET DRIVER						
High-Side nMOS On-Resistance	R _{DS-ONH}	$I_{LX} = 0.3A$		330	620	mΩ
Low-Side nMOS On-Resistance	R _{DS-ONL}	$I_{LX} = 0.3A$		170	320	mΩ
LX Leakage Current (LX to PGND ₋)	IL _{XLKG}	$V_{LX} = V_{IN} - 1V$; $V_{LX} = V_{PGND} + 1V$; $T_A = 25^\circ C$	-2		+2	μA
SOFT-START						
Soft-Start Current	I _{SS}	$V_{SS} = 0.5V$	4.7	5	5.3	μA
FEEDBACK (FB)						
FB Regulation Voltage	V _{FB_REG}		0.889	0.9	0.911	V
FB Input Bias Current	I _{FB}	$0 \leq V_{FB} \leq 1V$, $T_A = 25^\circ C$	-50		+50	nA
CURRENT LIMIT						
Peak Current-Limit Threshold	I _{PEAK-LIMIT}		1.5	1.75	2.00	A
Runaway Current-Limit Threshold	I _{RUNAWAY-LIMIT}		1.75	2	2.25	A
Negative Current-Limit Threshold				0.65		A
RT/SYNC AND TIMINGS						
Switching Frequency	f _{SW}	R _{RT} = OPEN	430	490	550	kHz
		R _{RT} = 51.1kΩ	370	400	430	kHz
		R _{RT} = 40.2kΩ	475	500	525	kHz
		R _{RT} = 8.06kΩ	1950	2200	2450	kHz
V _{FB} Undervoltage Trip Level to Cause HICCUP	V _{FB-HICF}		0.56	0.58	0.65	V

Electrical Characteristics (continued)

($V_{IN} = V_{EN/UVLO} = 24V$, $R_{RT} = 40.2k$, $C_{VCC} = 2.2\mu F$, $V_{PGND} = V_{GND} = EXT_{VCC} = 0$, $LX = SS = \overline{RESET} = OPEN$, V_{BST} to $V_{LX} = 5V$, $V_{FB} = 1V$, $T_A = -40^\circ C$ to $125^\circ C$, unless otherwise noted. Typical values are at $T_A = +25^\circ C$. All voltages are referenced to GND, unless otherwise noted.) (Note 1)

PARAMETER	SYMBOL	CONDITIONS	MIN	TYP	MAX	UNITS
HICCUP Timeout				32768		Cycles
Minimum On-Time	t_{ON_MIN}			60	80	ns
Minimum Off-Time	t_{OFF_MIN}		140	150	160	ns
LX Dead Time				5		ns
SYNC Frequency Capture Range		f_{SW} set by R_{RT}	$1.1 \times f_{SW}$		$1.4 \times f_{SW}$	
SYNC Pulse Width			50			ns
SYNC Threshold	V_{IH}		2.1			V
	V_{IL}				0.8	V
RESET						
RESET Output Level Low		$I_{\overline{RESET}} = 10mA$			400	mV
RESET Output Leakage Current		$T_A = T_J = 25^\circ C$, $V_{\overline{RESET}} = 5.5V$	-100		+100	nA
V_{OUT} Threshold for RESET Assertion	$V_{OUT-OKF}$	V_{FB} falling	90.5	92	94.6	%
V_{OUT} Threshold for RESET De-Assertion	$V_{OUT-OKR}$	V_{FB} rising	93.8	95	97.8	%
RESET Delay After FB Reaches 95% Regulation				1024		Cycles
THERMAL SHUTDOWN						
Thermal-Shutdown Threshold	T_{SHDNR}	Temp rising		165		$^\circ C$
Thermal-Shutdown Hysteresis	T_{SHDNHY}			10		$^\circ C$

Note 1: All limits are 100% tested at $T_A = +25^\circ C$. Limits over the operating temperature range and relevant supply voltage range are guaranteed by design and characterization

Typical Operating Characteristics

($V_{IN} = V_{EN/UVLO} = 24V$, $V_{GND} = V_{PGND} = 0V$, $C_{VIN} = 2.2\mu F$, $C_{VCC} = 2.2\mu F$, $C_{BST} = 0.1\mu F$, $C_{SS} = 5600pF$, $T_A = -40^\circ C$ to $+125^\circ C$, unless otherwise noted. Typical values are at $T_A = +25^\circ C$. All voltages are referenced to GND, unless otherwise noted.)

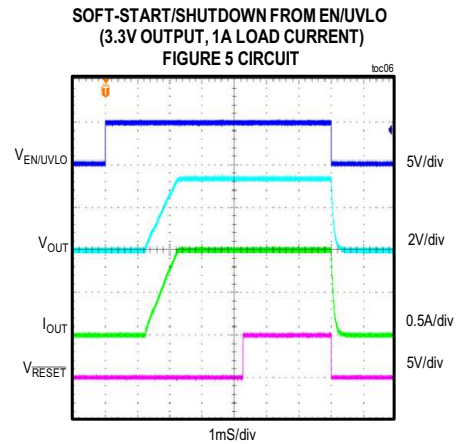
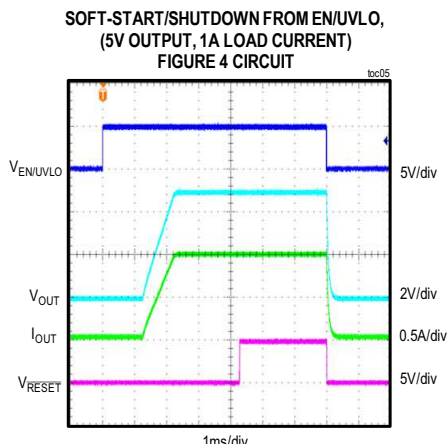
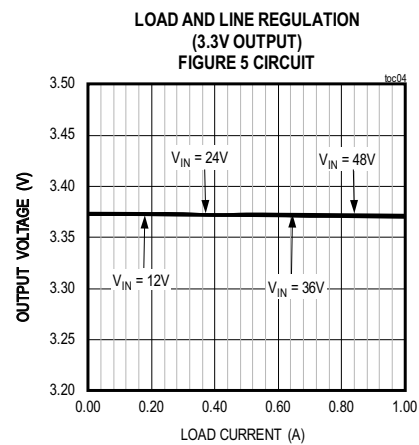
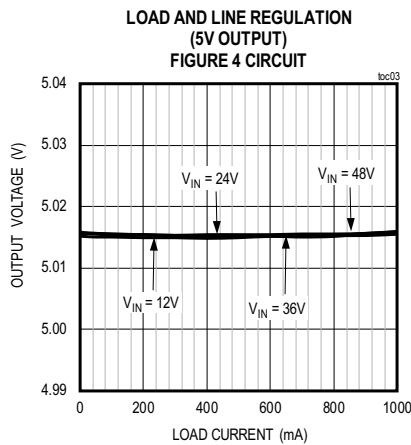
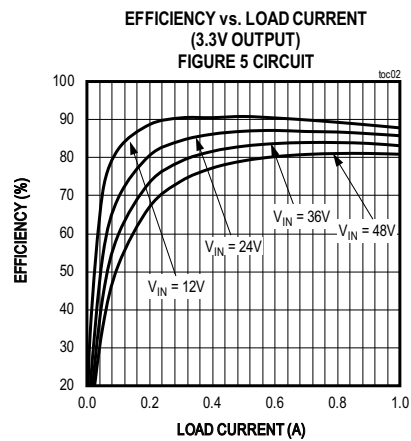
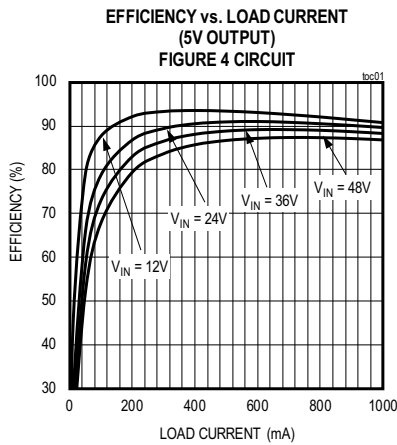

CONDITION: RESET IS PULLED UP TO V_{CC} WITH A 10k Ω RESISTOR

CONDITION: RESET IS PULLED UP TO V_{CC} WITH A 10k Ω RESISTOR

Typical Operating Characteristics (continued)

($V_{IN} = V_{EN/UVLO} = 24V$, $V_{GND} = V_{PGND} = 0V$, $C_{VIN} = 2.2\mu F$, $C_{VCC} = 2.2\mu F$, $C_{BST} = 0.1\mu F$, $C_{SS} = 5600pF$, $T_A = -40^{\circ}C$ to $+125^{\circ}C$, unless otherwise noted. Typical values are at $T_A = +25^{\circ}C$. All voltages are referenced to GND, unless otherwise noted.)

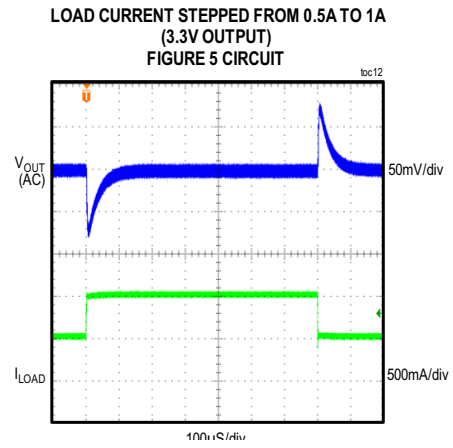
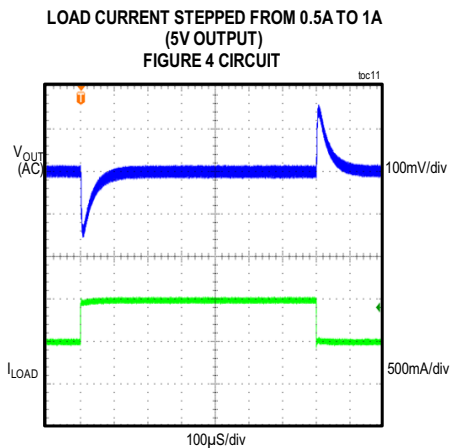
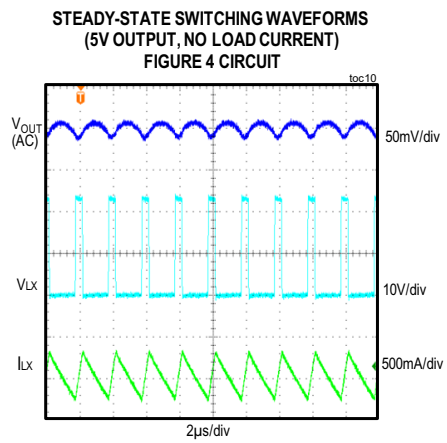
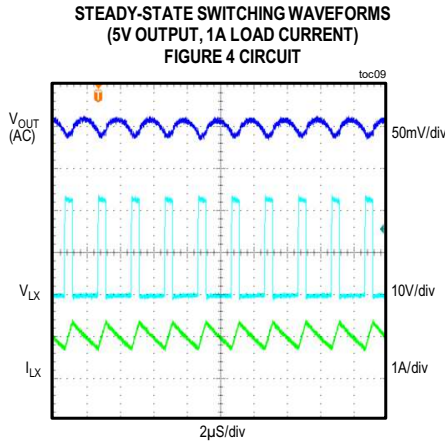
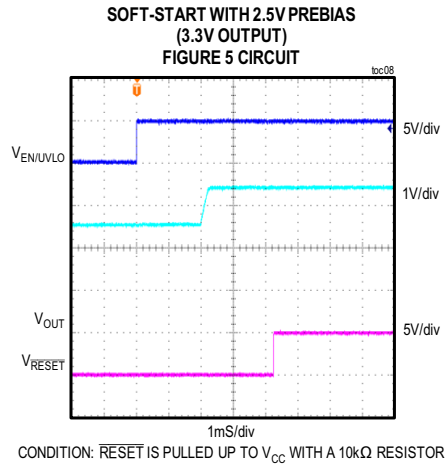
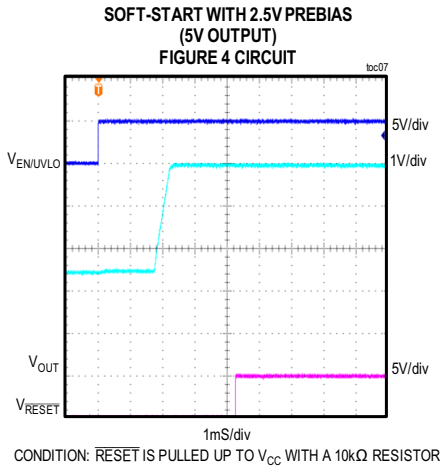

Typical Operating Characteristics (continued)

($V_{IN} = V_{EN}/UVLO = 24V$, $V_{GND} = V_{PGND} = 0V$, $C_{VIN} = 2.2\mu F$, $C_{VCC} = 2.2\mu F$, $C_{BST} = 0.1\mu F$, $C_{SS} = 5600pF$, $T_A = -40^\circ C$ to $+125^\circ C$, unless otherwise noted. Typical values are at $T_A = +25^\circ C$. All voltages are referenced to GND, unless otherwise noted.)

LOAD CURRENT STEPPED FROM NO LOAD TO 0.5A
(5V OUTPUT)
FIGURE 4 CIRCUIT

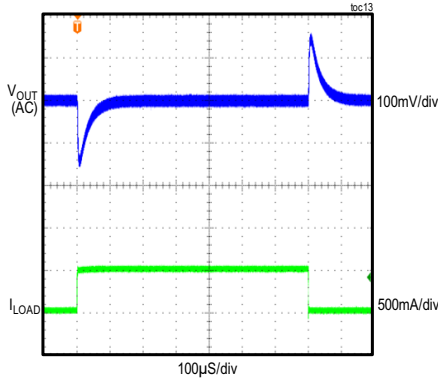

LOAD CURRENT STEPPED FROM NO LOAD TO 0.5A
(3.3V OUTPUT)
FIGURE 5 CIRCUIT

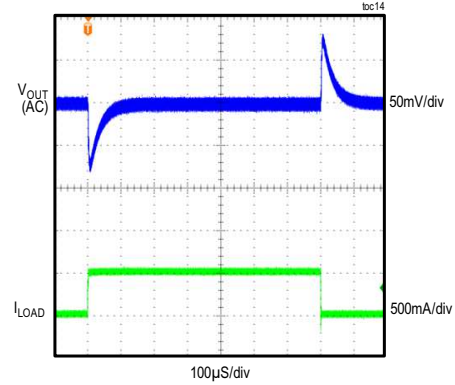

OVERLOAD PROTECTION
(5V OUTPUT) FIGURE 4 CIRCUIT

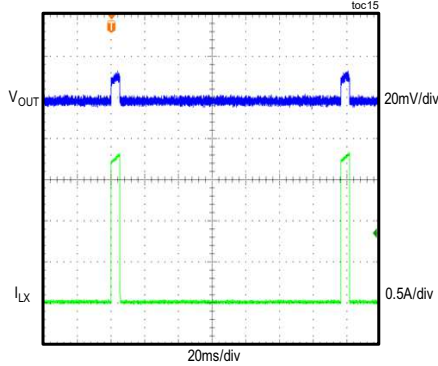

APPLICATION OF EXTERNAL CLOCK AT 600kHz
(5V OUTPUT) FIGURE 1 CIRCUIT

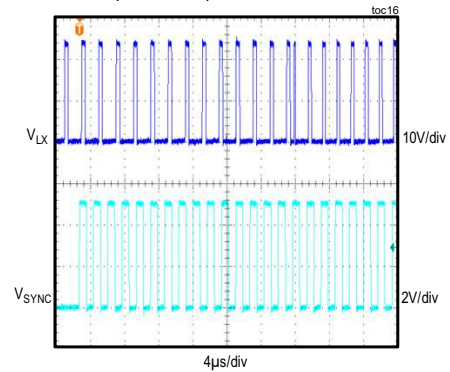

BODE PLOT
(5V OUTPUT, 1A LOAD CURRENT)
FIGURE 4 CIRCUIT

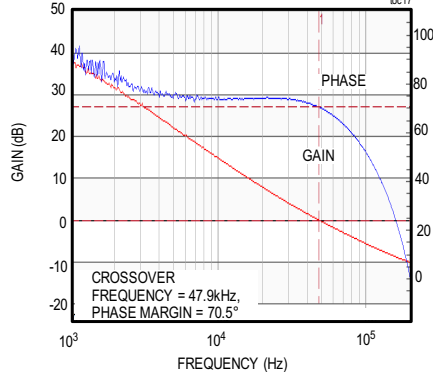

BODE PLOT
(3.3V OUTPUT, 1A LOAD CURRENT)
FIGURE 5 CIRCUIT

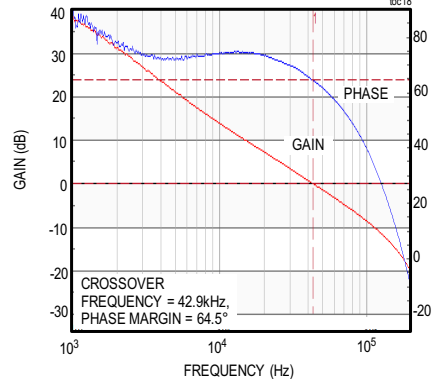

Pin Configuration

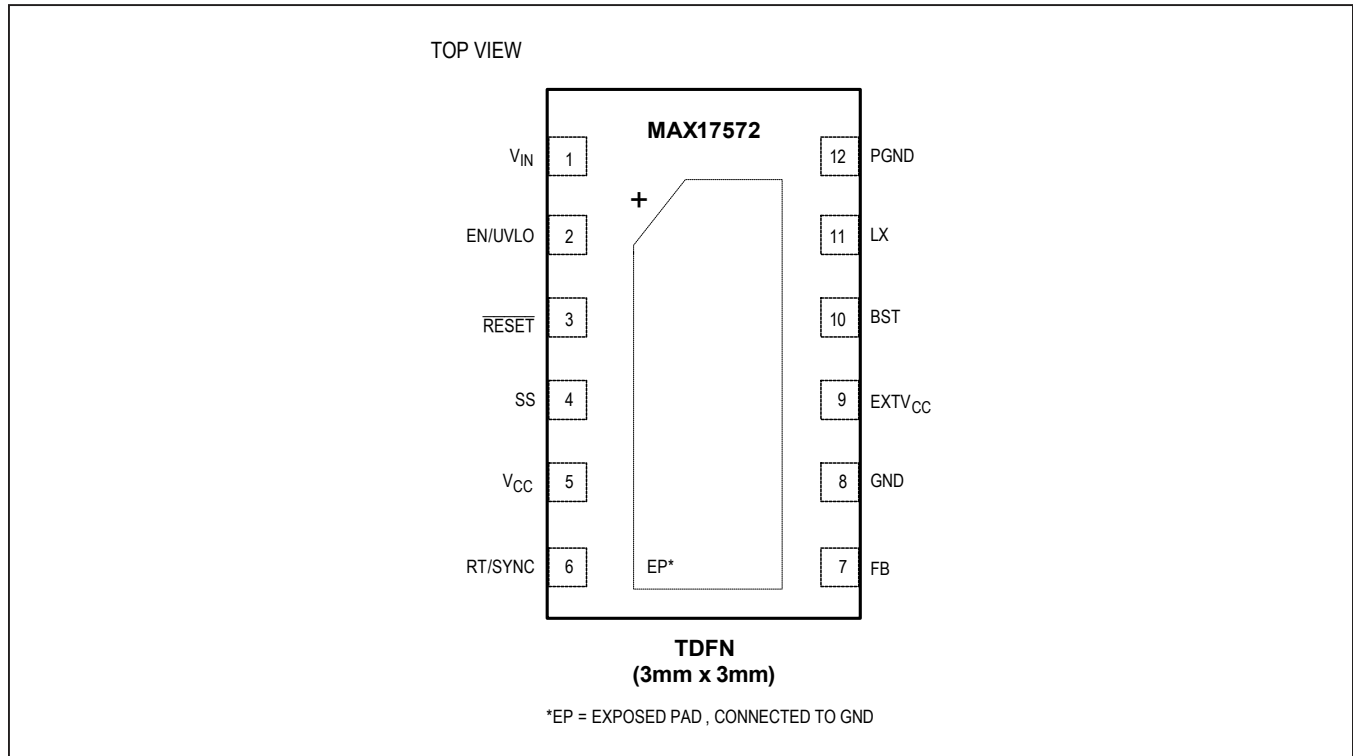

Pin Description

PIN	NAME	FUNCTION
V_{IN}	1	Power-Supply Input. The input supply range is from 4.5V to 60V.
EN/UVLO	2	Enable/Undervoltage Lockout Input. Drive EN/UVLO high to enable the output voltage. Connect to the centre of the resistive divider between V_{IN} and GND to set the input voltage (undervoltage threshold) at which the device turns on. Pull up to V_{IN} for always on.
\overline{RESET}	3	Open-Drain \overline{RESET} Output. The \overline{RESET} output is driven low if FB drops below 92% of its set value. \overline{RESET} goes high 1024 clock cycles after FB rises above 95% of its set value. \overline{RESET} is valid when the device is enabled and V_{IN} is above 4.5V.
SS	4	Soft-Start Input. Connect a capacitor from SS to GND to set the soft-start time.
V_{CC}	5	5V LDO Output. Bypass V_{CC} with 2.2 μ F/10V/X7R/0603(MURATA GRM188R71A225KE15) or 4.7 μ F/10V/X7R/0805(TDK C2012X7R1A475K085AC) ceramic capacitor to GND.
RT/SYNC	6	Oscillator Timing Resistor Input. Connect a resistor from RT/SYNC to GND to program the switching frequency from 400kHz to 2.2MHz. An external pulse can be applied to RT/SYNC through a coupling capacitor to synchronize the internal clock to the external pulse frequency. See the <i>Switching Frequency Selection and External Frequency Synchronization</i> section for details.
FB	7	Feedback Input. Connect FB to the center of the resistive divider between output voltage and GND.
GND	8	Analog Ground.
$EXTV_{CC}$	9	External Power-Supply Input for the Internal LDO. Applying a voltage between 4.84V and 24V at the $EXTV_{CC}$ pin will bypass the internal LDO and improve efficiency.

Pin Description (continued)

PIN	NAME	FUNCTION
BST	10	Boost Flying Capacitor. Connect a 0.1μF ceramic capacitor between BST and LX.
LX	11	Switching Node. Connect LX to the switching side of the inductor. LX is high impedance when the device is in shutdown mode.
PGND	12	Power Ground. Connect PGND externally to the power ground plane. Connect GND and PGND pins together at the ground return path of the V _{CC} bypass capacitor.
EP	—	Exposed Pad. Always connect EP to the GND pin of the IC. Also, connect EP to a large GND plane with several thermal vias for best thermal performance. Refer to the MAX17572 EV kit data sheet for an example of the correct method for EP connection and thermal vias.

Functional (or Block) Diagram

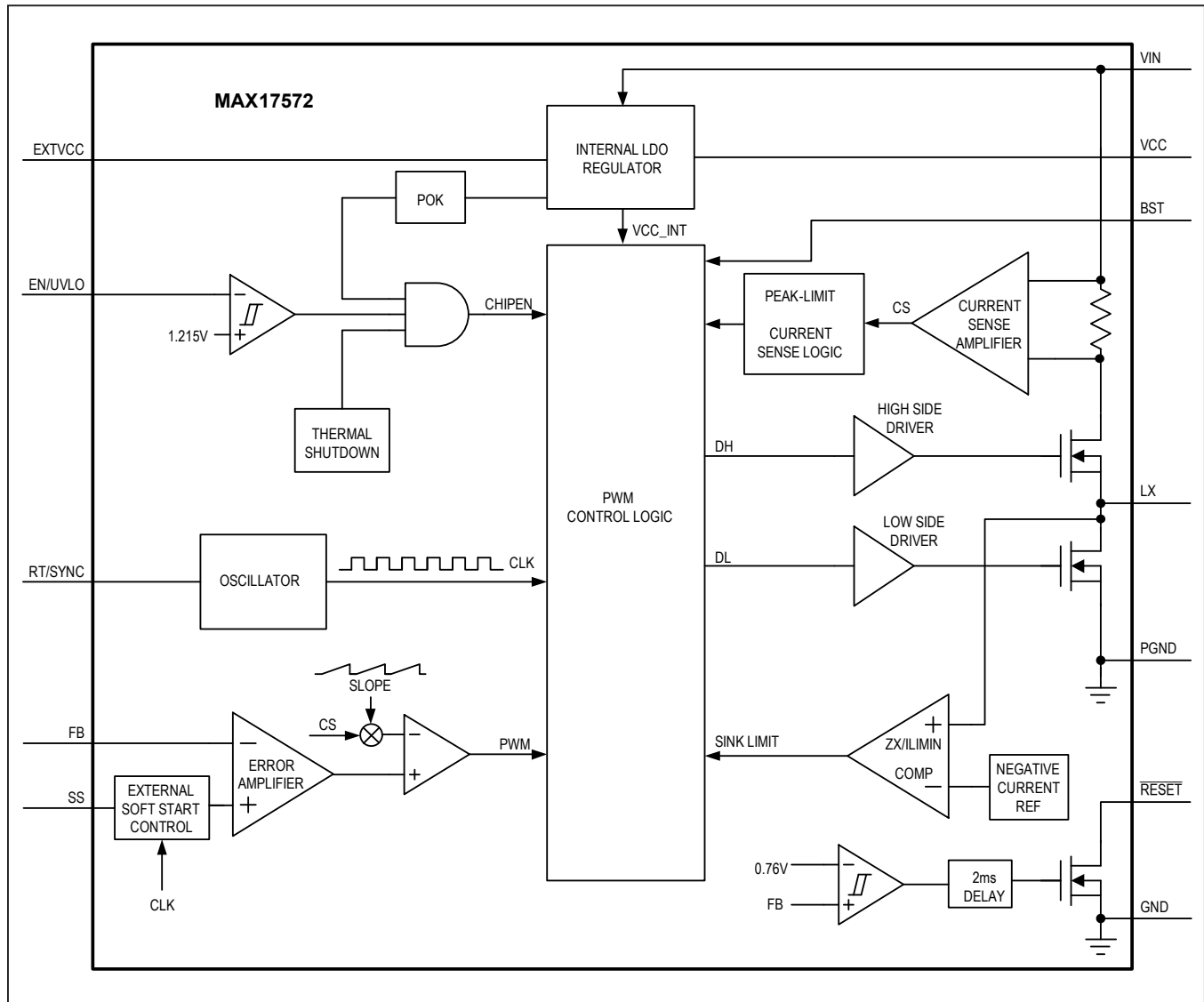

Detailed Description

The MAX17572 high-efficiency, high-voltage, synchronous step-down DC-DC converter with integrated MOSFETs operates over a 4.5V to 60V input. The converter can deliver up to 1A and generates output voltages from 0.9V up to $0.9 \times V_{IN}$. The feedback (FB) voltage is accurate to within $\pm 1.2\%$ over -40°C to $+125^{\circ}\text{C}$.

The device features a peak-current-mode control architecture. An internal transconductance error amplifier produces an integrated error voltage at an internal node that sets the duty cycle using a PWM comparator, a high-side current-sense amplifier, and a slope-compensation generator. At each rising edge of the clock, the high-side MOSFET turns on and remains on until either the appropriate or maximum duty cycle is reached, or the peak current limit is detected. During the high-side MOSFET’s on-time, the inductor current ramps up. During the second-half of the switching cycle, the high-side MOSFET turns off and the low-side MOSFET turns on. The inductor releases the stored energy as its current ramps down and provides current to the output.

The device features a RT/SYNC pin to program the switching frequency and to synchronize to an external clock. The device also features adjustable-input, undervoltage-lockout, adjustable soft-start, open-drain $\overline{\text{RESET}}$ and auxiliary bootstrap LDO.

Linear Regulator (V_{CC})

The device has two internal (low-dropout) regulators (LDOs) which powers V_{CC}. One LDO is powered from V_{IN} and the other LDO is powered from EXT_{V_{CC}} (EXT_{V_{CC}} LDO). Only one of the two LDOs is in operation at a time, depending on the voltage levels present at EXT_{V_{CC}}. If EXT_{V_{CC}} voltage is greater than 4.7V (typ), V_{CC} is powered from EXT_{V_{CC}}. If EXT_{V_{CC}} is lower than 4.7V (typ), V_{CC} is powered from V_{IN}. Powering V_{CC} from EXT_{V_{CC}} increases efficiency at higher input voltages. EXT_{V_{CC}} voltage should not exceed 24V.

Typical V_{CC} output voltage is 5V. Bypass V_{CC} to GND with either 2.2μF/10V/X7R/0603(MURATA GRM188R71A225KE15) or 4.7μF/10V/X7R/0805(TDK C2012X7R1A475K085AC) ceramic capacitor. V_{CC} powers the internal blocks and the low-side MOSFET driver and recharges the external bootstrap capacitor. Both LDO can source up to 60mA (typ). The MAX17572 employs an undervoltage-lockout circuit that forces the converter off when V_{CC} falls below 3.8V (typ). The converter is enabled again when V_{CC} is higher than 4.2V. The 400mV UVLO hysteresis prevents chattering on power-up/power-down. In applications where the buck converter output is connected to the EXT_{V_{CC}} pin, if the output is shorted to ground, then transfer from EXT_{V_{CC}} LDO to the internal LDO happens seamlessly without any impact on the normal functionality.

Switching Frequency Selection and External Frequency synchronization

The switching frequency of the MAX17572 can be programmed from 400kHz to 2.2MHz by using a resistor connected from the RT/SYNC pin to GND. When no resistor is used, the frequency is programmed to 490kHz. The switching frequency (f_{SW}) is related to the resistor connected at the RT pin (R_{RT}) by the following equation:

$$R_{RT} = \frac{21 \times 10^3}{f_{SW}} - 1.7$$

where R_{RT} is in kΩ and f_{SW} is in kHz. See [Table 1](#) for RT resistor values for a few common switching frequencies. The RT/SYNC pin can be used to synchronize the device’s internal oscillator to an external system clock. A resistor must be connected from the RT/SYNC pin to GND to be able to synchronize the MAX17572 to an external clock. The external clock should be coupled to the RT/SYNC pin through a network, as shown in [Figure 1](#). When an external clock is applied to MODE/SYNC pin, the internal oscillator frequency changes to external clock frequency (from original frequency based on RT setting) after detecting 16 external clock edges. The external clock logic-high level should be higher than 2.1V, logic-low level lower than 0.8V and the pulse width of the external clock should be more than 50ns. The RT resistor should be selected to set the switching frequency at 10% lower than the external clock frequency.

Table 1. Switching Frequency vs. RT Resistor

SWITCHING FREQUENCY (kHz)	RT RESISTOR (kΩ)
400	51.1
500	OPEN
1000	19.1
2200	8.06

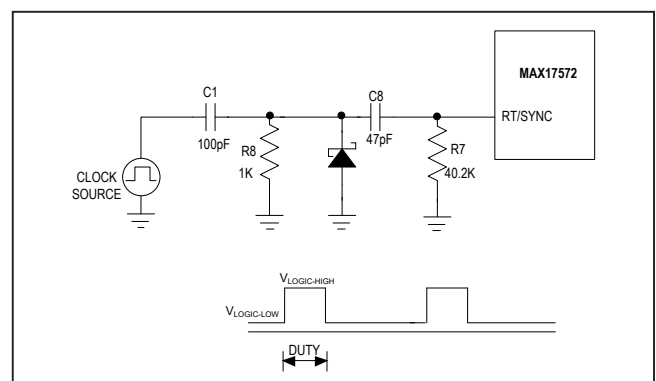

Figure 1. External Clock Synchronization

Operating Input Voltage Range

The minimum and maximum operating input voltages for a given output voltage should be calculated as follows:

$$V_{IN(MIN)} = \frac{V_{OUT} + (I_{OUT(MAX)} \times (R_{DCR(MAX)} + R_{DS_ONL(MAX)}))}{1 - (f_{SW(MAX)} \times t_{OFF_MIN(MAX)})} + (I_{OUT(MAX)} \times (R_{DS_ONH(MAX)} - R_{DS_ONL(MAX)}))$$

$$V_{IN(MAX)} = \frac{V_{OUT}}{f_{SW(MAX)} \times t_{ON_MIN(MAX)}}$$

where:

V_{OUT} = Steady-state output voltage

$I_{OUT(MAX)}$ = Maximum load current

$R_{DCR(MAX)}$ = Worst-case DC resistance of the inductor

$f_{SW(MAX)}$ = Maximum switching frequency

$t_{OFF_MIN(MAX)}$ = Worst-case minimum switch off-time (160ns)

$t_{ON_MIN(MAX)}$ = Worst-case minimum switch on-time (80ns)

$R_{DS_ONH(MAX)}$ = Worst-case on-state resistances and high-side internal MOSFET

$R_{DS_ONL(MAX)}$ = Worst-case on-state resistances and low-side external MOSFET

Overcurrent Protection

The device is provided with a robust overcurrent protection scheme that protects the device under overload and output short-circuit conditions. A cycle-by-cycle peak current limit turns off the high-side MOSFET whenever the high-side switch current exceeds an internal limit of 1.75A (typ). A runaway current limit on the high-side switch current at 2A (typ) protects the device under high input voltage, short-circuit conditions when there is insufficient output voltage available to restore the inductor current that was built up during the on period of the step-down converter. One occurrence of runaway current limit triggers a hiccup mode. In addition, if, due to a fault condition, feedback voltage drops to 0.58V (typ) any time after soft-start is complete, hiccup mode is triggered. In hiccup mode, the converter is protected by suspending switching for a hiccup timeout period of 32,768 clock cycles. Once the hiccup timeout period expires, soft-start is attempted again. Note that when soft-start is attempted under an overload condition, if the feedback voltage does not exceed 0.58V, the device switches at half the programmed switching frequency. Hiccup mode of operation ensures low power dissipation under output short-circuit conditions.

RESET Output

The device includes a \overline{RESET} comparator to monitor the status of the output voltage. The open-drain \overline{RESET} output requires an external pullup resistor. \overline{RESET} goes high (high impedance) 1024 switching cycles after the regulator output increases above 95% of the designed nominal regulated voltage. \overline{RESET} goes low when the regulator output

voltage drops to below 92% of the set nominal output voltage. \overline{RESET} also goes low during thermal shutdown.

Prebiased Output

When the device starts into a prebiased output, both the high-side and low-side switches are turned off so that the converter does not sink current from the output. High-side and low-side switches do not start switching until the PWM comparator commands the first PWM pulse. The output voltage is then smoothly ramped up to the target value in alignment with the internal reference.

Thermal Shutdown Protection

Thermal shutdown protection limits total power dissipation in the device. When the junction temperature of the device exceeds +165°C, an on-chip thermal sensor shuts down the device, allowing the device to cool. The thermal sensor turns the device on again after the junction temperature cools by 10°C. Soft-start is deasserted during thermal shutdown and initiates the start-up operation when the device recovers from thermal shutdown. Carefully evaluate the total power dissipation (see the [Power Dissipation](#) section) to avoid unwanted triggering of the thermal shutdown protection in normal operation.

Applications Information

Input Capacitor Selection

The input filter capacitor reduces peak currents drawn from the power source and reduces noise and voltage ripple on the input caused by the circuit's switching. The input capacitor RMS current (I_{RMS}) is defined by the following equation:

$$I_{RMS} = I_{OUT(MAX)} \times \frac{\sqrt{V_{OUT} \times (V_{IN} - V_{OUT})}}{V_{IN}}$$

where, $I_{OUT(MAX)}$ is the maximum load current. I_{RMS} has a maximum value when the input voltage equals twice the output voltage ($V_{IN} = 2 \times V_{OUT}$), so $I_{RMS(MAX)} = I_{OUT(MAX)}/2$.

Choose an input capacitor that exhibits less than +10°C temperature rise at the RMS input current for optimal long-term reliability. Use low-ESR ceramic capacitors with high-ripple-current capability at the input. X7R capacitors are recommended in industrial applications for their temperature stability. Calculate the input capacitance using the following equation:

$$C_{IN} = \frac{I_{OUT(MAX)} \times D \times (1-D)}{\eta \times f_{SW} \times \Delta V_{IN}}$$

where $D = V_{OUT}/V_{IN}$ is the duty ratio of the converter, f_{SW} is the switching frequency, ΔV_{IN} is the allowable input voltage ripple, and η is the efficiency.

In applications where the source is located distant from the device input, an electrolytic capacitor should be added in parallel to the ceramic capacitor to provide necessary damping for potential oscillations caused by the inductance of the longer input power path and input ceramic capacitor.

Inductor Selection

Three key inductor parameters must be specified for operation with the device: inductance value (L), inductor saturation current (I_{SAT}) and DC resistance (R_{DCR}). The switching frequency and output voltage determine the inductor value as follows:

$$L = \frac{2 \times V_{OUT}}{f_{SW}}$$

Where V_{OUT} and f_{SW} are nominal values and f_{SW} is in Hz. Select an inductor whose value is nearest to the value calculated by the previous formula.

Select a low-loss inductor closest to the calculated value with acceptable dimensions and having the lowest possible DC resistance. The saturation current rating (I_{SAT}) of the inductor must be high enough to ensure that saturation can occur only above the peak current-limit value.

Output Capacitor Selection

X7R ceramic output capacitors are preferred due to their stability over temperature in industrial applications. The output capacitors are usually sized to support a step load of 50% of the maximum output current in the application, so the output voltage deviation is contained to 3% of the output voltage change. The minimum required output capacitance can be calculated as follows:

$$C_{OUT} = \frac{60}{V_{OUT}}$$

Where C_{OUT} is in μF . Derating of ceramic capacitors with DC-voltage must be considered while selecting the output capacitor. Derating curves are available from all major ceramic capacitor vendors.

Soft-Start Capacitor Selection

The device implements adjustable soft-start operation to reduce inrush current. A capacitor connected from the SS pin to GND programs the soft-start time. The selected output capacitance (C_{SEL}) and the output voltage (V_{OUT}) determine the minimum required soft-start capacitor as follows:

$$C_{SS} \geq 56 \times 10^{-6} \times C_{SEL} \times V_{OUT}$$

The soft-start time (t_{SS}) is related to the capacitor connected at SS (C_{SS}) by the following equation:

$$t_{SS} = \frac{C_{SS}}{5.55 \times 10^{-6}}$$

For example, to program a 2ms soft-start time, a 12nF capacitor should be connected from the SS pin to GND.

Adjusting Output Voltage

Set the output voltage with a resistive voltage-divider connected from the positive terminal of the output capacitor (V_{OUT}) to SGND (see [Figure 2](#)). Connect the center node of the divider to the FB pin. Use the following procedure to choose the resistive voltage-divider values:

Calculate resistor R4 from the output to the FB pin as follows:

$$R4 = \frac{1850}{C_{OUT_SEL}}$$

Where C_{OUT_SEL} (in μF) is the actual derated value of the output capacitance used and R4 is in $\text{k}\Omega$. The minimum allowable value of R4 is $(5.6 \times V_{OUT})$, where R4 is in $\text{k}\Omega$. If the value of R4 calculated using the above equation is less than $(5.6 \times V_{OUT})$, increase the value of R4 to at least $(5.6 \times V_{OUT})$.

$$R5 = \frac{R4 \times 0.9}{(V_{OUT} - 0.9)}$$

R5 is in $\text{k}\Omega$.

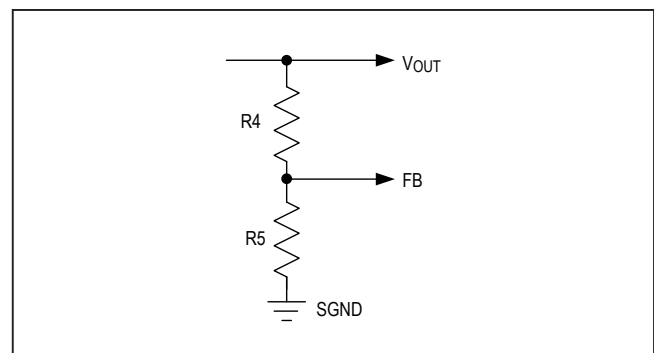

Figure 2. Adjusting Output Voltage

Setting the Undervoltage Lockout Level

The device offers an adjustable input undervoltage-lockout level. Set the voltage at which the device turns on with a resistive voltage-divider connected from V_{IN} to SGND (see Figure 3). Connect the center node of the divider to EN/UVLO. Choose R1 to be 3.3M Ω and then calculate R2 as follows:

$$R2 = \frac{1.215 \times R1}{(V_{INU} - 1.215)}$$

where V_{INU} is the voltage at which the device is required to turn on. Ensure that V_{INU} is higher than $0.8 \times V_{OUT}$.

If the EN/UVLO pin is driven from an external signal source, a series resistance of minimum 1k Ω is recommended to be placed between the signal source output and the EN/UVLO pin, to reduce voltage ringing on the line.

Power Dissipation

At a particular operating condition, the power losses that lead to temperature rise of the part are estimated as follows:

$$P_{LOSS} = (P_{OUT} \times (\frac{1}{\eta} - 1)) - (I_{OUT}^2 \times R_{DCR})$$

$$P_{OUT} = V_{OUT} \times I_{OUT}$$

Where P_{OUT} is the output power, η is the efficiency of the converter and R_{DCR} is the DC resistance of the inductor (see the [Typical Operating Characteristics](#) for more information on efficiency at typical operating conditions).

For a typical multilayer board, the thermal performance metrics for the package are given below:

$$\theta_{JA} = 41^\circ\text{C/W}$$

$$\theta_{JC} = 8.5^\circ\text{C/W}$$

The junction temperature of the device can be estimated at any given maximum ambient temperature (T_{A_MAX}) from the following equation:

$$T_{J_MAX} = T_{A_MAX} + (\theta_{JA} \times P_{LOSS})$$

If the application has a thermal-management system that ensures that the exposed pad of the device is maintained at a given temperature (T_{EP_MAX}) by using proper heat sinks, the junction temperature of the device can be estimated at any given maximum ambient temperature as:

$$T_{J_MAX} = T_{EP_MAX} + (\theta_{JC} \times P_{LOSS})$$

Junction temperatures greater than +125 $^\circ\text{C}$ degrades operating lifetimes.

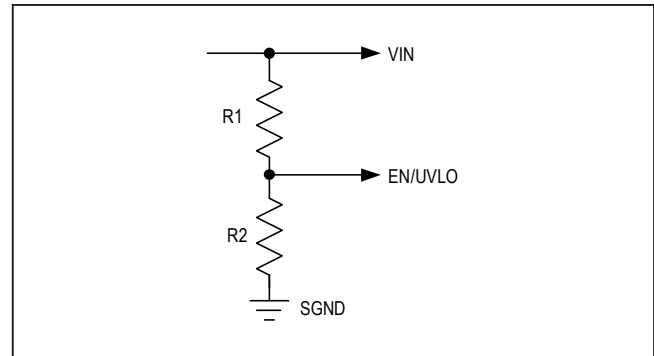

Figure 3. Setting the Input Undervoltage Lockout

PCB Layout Guidelines

All connections carrying pulsed currents must be very short and as wide as possible. The inductance of these connections must be kept to an absolute minimum due to the high di/dt of the currents. Since inductance of a current carrying loop is proportional to the area enclosed by the loop, if the loop area is made very small, inductance is reduced. Additionally, small-current loop areas reduce radiated EMI.

A ceramic input filter capacitor should be placed close to the V_{IN} pins of the IC. This eliminates as much trace inductance effects as possible and gives the IC a cleaner voltage supply. A bypass capacitor for the V_{CC} pin also should be placed close to the pin to reduce effects of trace impedance.

When routing the circuitry around the IC, the analog small-signal ground and the power ground for switching currents must be kept separate. They should be connected together at a point where switching activity is at a minimum, typically the return terminal of the V_{CC} bypass capacitor. This helps keep the analog ground quiet. The ground plane should be kept continuous/unbroken as far as possible. No trace carrying high switching current should be placed directly over any ground plane discontinuity.

PCB layout also affects the thermal performance of the design. A number of thermal vias that connect to a large ground plane should be provided under the exposed pad of the part, for efficient heat dissipation.

For a sample layout that ensures first pass success, refer to the MAX17572 evaluation kit layout available at www.maximintegrated.com.

Typical Application Circuit

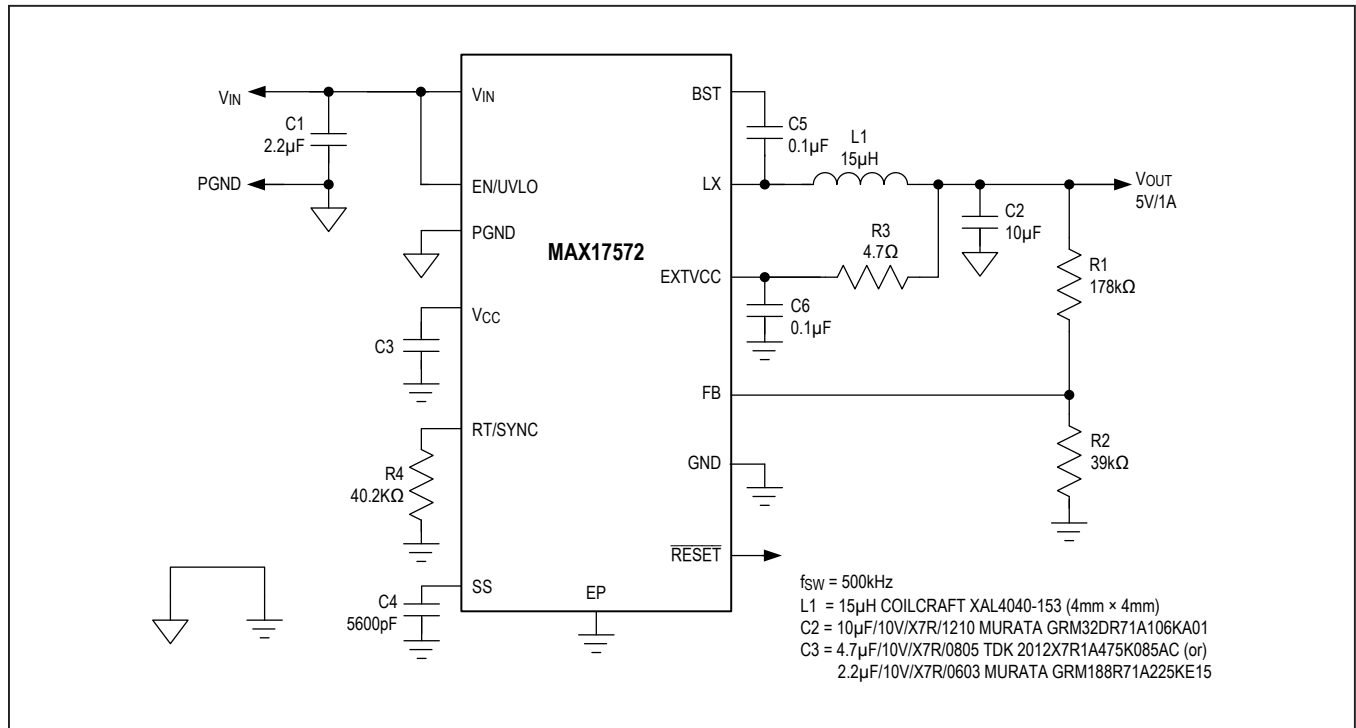

Figure 4. Typical Application Circuit for 5V Output

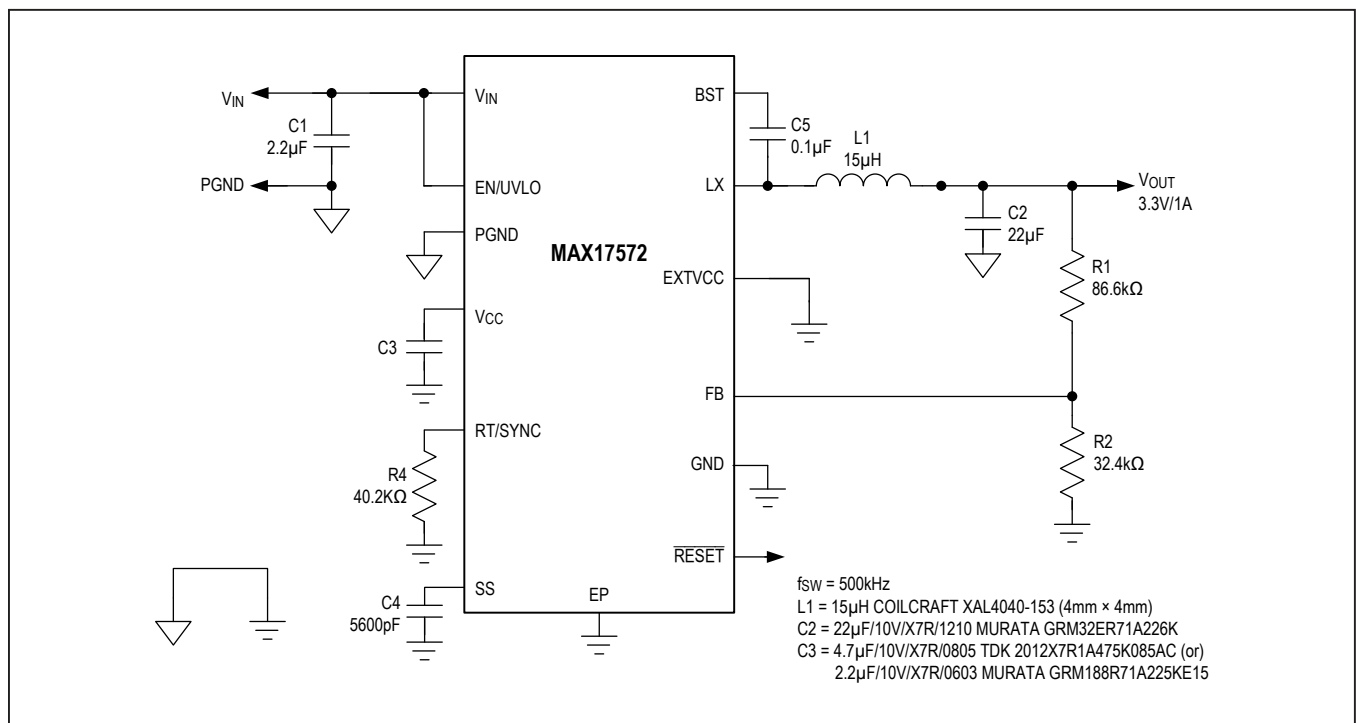

Figure 5. Typical Application Circuit for 3.3V Output

MAX17572

4.5V–60V, 1A, High-Efficiency, Synchronous
Step-Down DC-DC Converter
with Internal Compensation

Ordering Information

PART	PIN-PACKAGE	PACKAGE-SIZE
MAX17572ATC+	12 TDFN	3mm × 3mm

+Denotes a lead(Pb)-free/RoHS-compliant package.

Chip Information

PROCESS: BiCMOS

Revision History

REVISION NUMBER	REVISION DATE	DESCRIPTION	PAGES CHANGED
0	9/16	Initial release	—
1	3/17	Updated <i>Absolute Maximum Ratings</i> and <i>Typical Operating Characteristics</i> sections	2, 5–7
2	6/17	Updated VCC capacitor to 4.7μF 0805. Updated global characteristics for <i>Electrical Characteristics</i> table and <i>Typical Operating Characteristics</i> . Updated Function for V _{CC} in <i>Pin Description</i> table. Updated <i>Detailed Description</i> , Equation 1, added a reference to Figure 3 in the <i>Setting the Undervoltage Lockout Level</i> section. Updated <i>Typical Application Circuits</i> .	2–8, 10–11, 13–14
3	5/18	Updated the <i>Absolute Maximum Ratings</i> , <i>Detailed Description</i> , <i>Linear Regulator</i> , <i>Operating Input-Voltage Range</i> , <i>RESET Output</i> , <i>Thermal Shutdown Protection</i> , <i>Application Information</i> , and <i>Power Dissipation</i> sections. Updated the <i>Electrical Characteristics</i> and <i>Typical Operating Characteristics</i> global characteristics, TOC05–TOC08, and the <i>Pin Description</i> table.	2–11, 13–14
3.1		Corrected references in the <i>Pin Description</i> table.	8

For pricing, delivery, and ordering information, please contact Maxim Direct at 1-888-629-4642, or visit Maxim Integrated's website at www.maximintegrated.com.

Maxim Integrated cannot assume responsibility for use of any circuitry other than circuitry entirely embodied in a Maxim Integrated product. No circuit patent licenses are implied. Maxim Integrated reserves the right to change the circuitry and specifications without notice at any time. The parametric values (min and max limits) shown in the *Electrical Characteristics* table are guaranteed. Other parametric values quoted in this data sheet are provided for guidance.