

PAGE 1/2

ISSUE 11-04-17

SERIE : SPnT

PART NUMBER : R573F03200

## RF CHARACTERISTICS

Number of ways : 12  
 Frequency range : 0 - 18 GHz  
 Impedance : 50 Ohms

Frequency (GHz)	DC - 3	3 - 8	8 - 12.4	12.4 - 15	15 - 18
VSWR max	1.20	1.40	1.60	1.70	1.80
Insertion loss max	0.20 dB	0.40 dB	0.60 dB	0.70 dB	0.80 dB
Isolation min	80 dB	70 dB	60 dB	60 dB	50 dB
Average power (*)	240 W	150 W	120 W	110 W	100 W

## ELECTRICAL CHARACTERISTICS

Actuator : **NORMALLY OPEN**  
 Nominal current \*\* : 102 mA  
 Actuator voltage (Vcc) : 28V (24 to 30V) / **NEGATIVE COMMON**  
 Terminals : **solder pins (250°C max. / 30 sec.)**

## MECHANICAL CHARACTERISTICS

Connectors : **SMA female per MIL-C 39012**  
 Life : **2 million cycles per position**  
 Switching Time\*\*\* : **< 15 ms**  
 Construction : **Splashproof**  
 Weight : **< 400 g**

## ENVIRONMENTAL CHARACTERISTICS

Operating temperature range : **-40°C to +85°C**  
 Storage temperature range : **-55°C to +85°C**

(\* Average power at 25°C per RF Path)

(\*\* At 25° C ±10%)

(\*\*\* Nominal voltage ; 25° C)



PAGE 2/2

ISSUE 11-04-17

SERIE : SPnT

PART NUMBER : R573F03200

DRAWING

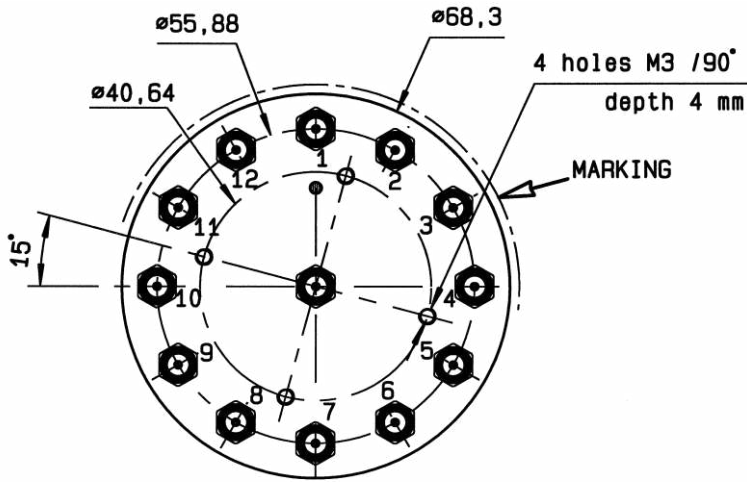

Voltage	RF Continuity
-C +1	IN ↔ 1
-C +2	IN ↔ 2
-C +3	IN ↔ 3
-C +4	IN ↔ 4
-C +5	IN ↔ 5
-C +6	IN ↔ 6
-C +7	IN ↔ 7
-C +8	IN ↔ 8
-C +9	IN ↔ 9
-C +10	IN ↔ 10
-C +11	IN ↔ 11
-C +12	IN ↔ 12

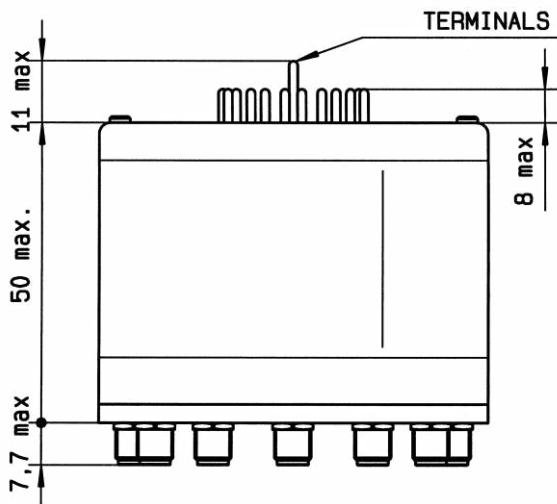

LABEL

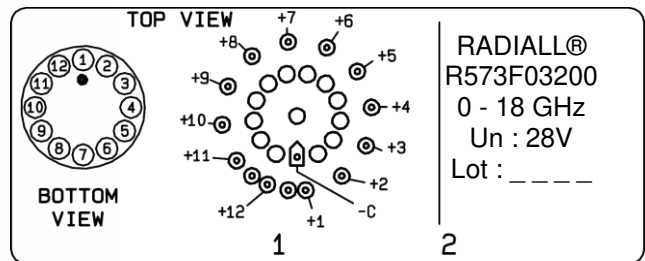

General tolerances : ±0,5 mm [0,02 in]

SCHEMATIC DIAGRAM

