

TE AC-5ND PNEUMATIC CRIMPING TOOL

TE AC-5ND エアー式クリンプツール

Part Number 2155364

部品番号 2155364



LANGUAGE 言語

ENGLISH From 2 of 16 to 10 of 17.
JAPANESE From 11 of 16 to 17 of 17.

英語 From 2 of 16 to 10 of 17.
日本語 From 11 of 16 to 17 of 17.

この書類は当社により変更管理されており、必要に応じ変更されます。

最新の改訂に関しては当社本支店にお問い合わせ下さい。

This TE controlled document is subject to change. For latest revision call local TE representative.

This Operator's Guide and Service Manual contains details on using the equipment and important notes for its use.

Please read and understand all of the instructions and safety information in this manual to operate the equipment safely.

CONTENTS

CAUTIONS	3 of 17
LUBRICATION UNIT	3 of 17
SPECIFICATION	4 of 17
EXPLODED VIEW PARTS LIST	5 of 17
OPERATION MANUAL	6 of 17
HOW TO LOAD AND UNLOAD THE JAWS	7 of 17
CHECK AND DISASSEMBLY OF EACH PART	8 of 17
PISTON	8 of 17
EXHAUST VALVE	9 of 17
FOOT PEDAL	9 of 17
HOW TO HANDLE O-RING, PACKING AND BALL MADE OF POLYURETHANE ..	10 of 17
OPTION	10 of 17

CAUTIONS

1. On the replacement of jaws, be sure to stop the supply of air from the source.
2. Never operate this tool for crimping with no matter to be pressed held therein.
3. As the jaws operate with instantaneous action, be careful of the hands near the jaws.
4. Be sure to push and release the foot valve securely. Any incomplete pressing of the foot valve will cause leakage of air, resulting in dropping the performance of the tool. When the foot pedal is not operated or in stand-by, be sure to separate the foot from the pedal without fail.

LUBRICATION UNIT

As these parts such as filter, oiler, regulator, and pressure gauge are assembled into a body, providing this unit on the line of air hoses will make it possible to feed clean air with a definite pressure and clean lubricating oil automatically, preventing any possible break-down of the tool due to over-pressure as lengthening the useful life of the tool.

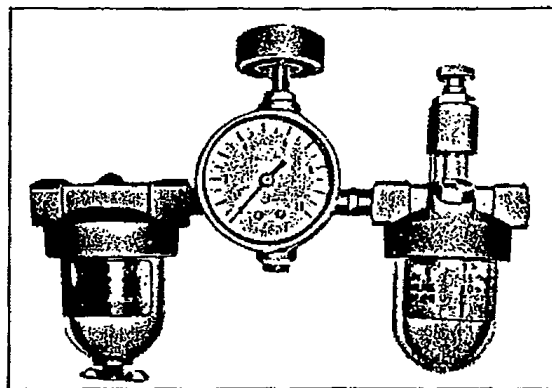

SPECIFICATION

Motive mechanism: Piston's reciprocating motion plus linking mechanism thereto.

Applicable air pressure: 5 to 6 kg/cm² (Gauge pressure)

Out put: 1,300 kg (In case of 5kg/cm² of pneumatic pressure)

How to handle: Opening and closing of the foot valve by foot-operation.

Dimensions: L 190mm x H 99mm x W 92mm

Weight: 2.5 kg

Hose withstand pressure: Maximum pressure limit 10 kg/cm²
(with a coupler of PT 1/4)

Air requirement: 33 ℓ /min
(In case of reciprocation of 30 cycles/min
at the pneumatic pressure of 6 kg/cm²)

Crimping capacity (requiring the replacement of jaws:
Non-insulated terminal... 1.25 to 5.5mm²
Insulated terminal ... 1.25 to 5.5mm²

Standard accessories: Foot valve (with 2 pcs. of air hose (2m)

(Note : These specifications may be modified for improvement without notice) .

EXPLODED VIEW AND PARTS LIST

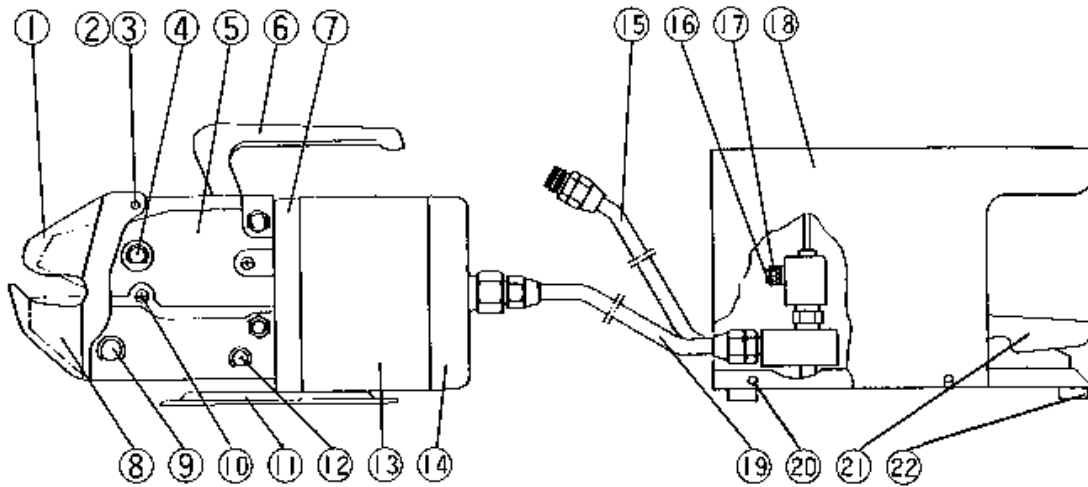

NUMBER	NAME	NUMBER	NAME
1	Safety cover	12	* AC5ND PIN 64 # 2155364-3
2	Pin (95)	13	Cylinder
3	E Ring 2.5	14	Rear cover
4	* AC5ND PIN 63 # 2155364-2	15	Air hose (A)
5	Cover	16	Adjusting knob
6	Grip	17	Lock nut
7	Front cover	18	Cover, Foot pedal
8	Head --- Optional	19	Air hose (B)
9	* AC5ND PIN 65 # 2155364-4	20	Cross recessed head screw M5×6
10	Cross recessed head screw M4×6	21	Foot pedal
11	Base	22	Rubber pad

* With Stop ring (CE-Ring).

Part number.

OPERATION MANUAL

1. Attaching of jaws:

Attach the suitable jaw for the size of electric wire and the type of terminal.
(As for how to attach it and to remove it, refer to P.6).

2. Adjustment of air pressure:

Adjust the air pressure within the range of 5 to 6kg/cm² according to the type of terminal.
As the performance and useful life of this tool will be affected if the air pressure stands beyond the range mentioned above, be sure to check the air pressure from time to time if it is proper.

3. Removing of moisture

As any moisture gets into this tool, this will cause it to be rusted, dropping its performance and shortening its useful life, be sure to provide a drain valve on its piping and to remove any moisture deposited in the pipe line prior to its operation.

4. Lubrication of each part:

Lubricate the hinge shafts, fulcrum shaft, and the link part with spindle oil through the lubricating orifice and also lubricate the cylinder part with spindle oil through the hose coupling respectively from time to time.

5. Attaching of air hose:

Among 2 pcs. of hose attached to the accessory foot valve, the one attached with a cap nut (PF 3/8") shall be attached to the main body and the other one (PT 1/4" male-screw) shall be attached to the outlet of compressed air.

6. Crimping work:

Keeping the terminal and the electric wire in the correct position of the jaw, supporting with both hands. Push the foot pedal fully, taking care of the hands.
When the surface of the jaws have touched with each other, the crimping work is finished.
At this instant, release the foot from the foot pedal.

The lubrication hole which is
above an aluminum cover

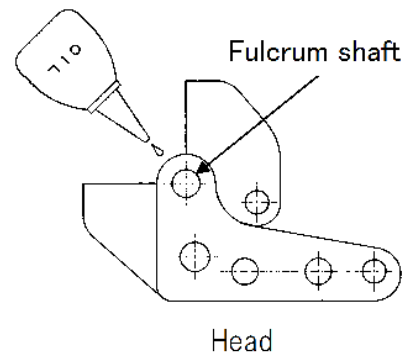
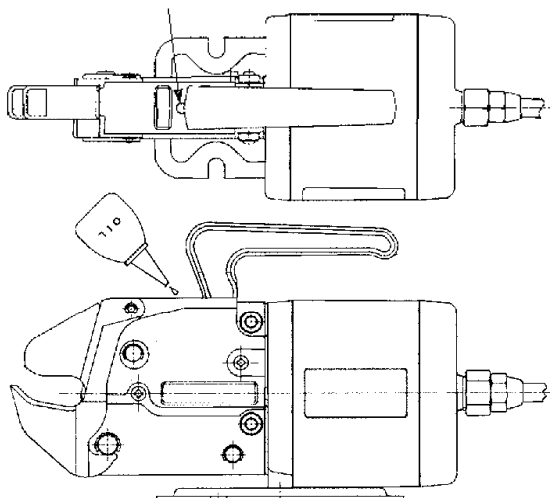

HOW TO LOAD AND UNLOAD THE JAWS

CAUTION

1. On the replacement of jaws, be sure to stop the supply of air from the source.
2. Never operate this tool for crimping with no matter to be pressed held therein.
3. As the jaws operate with instantaneous action, be careful of the hands near the jaws.
4. Be sure to push and release the foot valve securely. Any incomplete pressing of the foot valve will cause leakage of air, resulting in dropping the performance of the tool. When the foot pedal is not operated or in stand-by, be sure to separate the foot from the pedal without fail.

HOW TO LOAD AND UNLOAD THE JAWS

a) Loading of the jaw:

After inserting the jaws into the prescribed position of main body, insert AC5ND Pin 64, AC5ND Pin 63, AC5ND Pin 65 in this order into their holes till their stop rings have touched with the setting plate as shown in the figure.

Note: If their insertion is incomplete, the tool may be damaged by falling of the Pins, etc.

b) Unloading of the head:

The hinge shafts can be pulled out by pushing from the side shown in the figure. In this case, if it is hard to pull out the Pin, it is recommended to tap it with a hammer, placing a bit on opposite side.

The order of unloading the Pins is to be performed in the same order with that in case of loading of them, AC5ND Pin 64, AC5ND Pin 63, and AC5ND Pin 65 in this order.

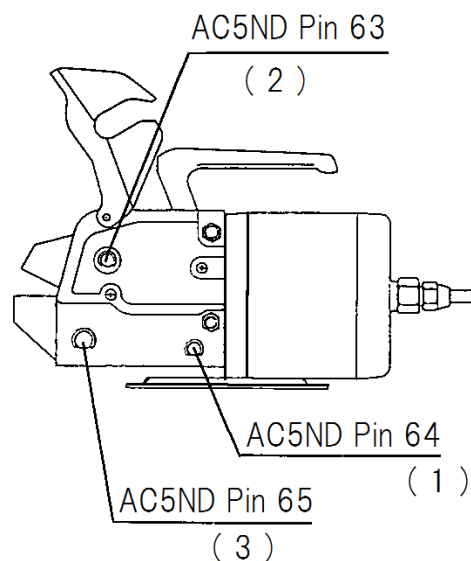

CHECK AND DISASSEMBLY OF EACH PART**PISTON**

- Check:**
1. Check if any air leakage is found through the exhaust port provided on the front side of the front cover when the foot valve has been depressed.
 2. Check if any abnormal noise, stick-slip motion, or abnormal heating is found when the piston is reciprocating, checking the speed of motion at the same time.

- DISASSEMBLY:**
1. Pull out the piano wire through the slot on the under side of the rear part of main body.
(Note: Be sure to pull the piano wire in the direction of non-pointed tip of the piano wire.)
 2. Pull the packing disk out of the cylinder.
(Note: In case it is hard to pull it out, it is recommended to blow compressed air thereinto so as to make it easy, provided that in this case it is necessary to fix the main body and hold the rear cover by both hands as the packing disk will be jetted out instantaneously.)
 3. Keeping the main body into a vice with the situation as the piston is slightly pushed, disconnecting the hex-nut M8 and releasing the vice slowly will pull the piston automatically by means of the force of the spring incorporated therein.
(Note: Never disconnect only the hex-nut hastily because it will allow the piston to jet out instantaneously by means of the force of the spring. If so, it is dangerous and causes damage to other parts.)

EXHAUST VALVE

- Check:**
1. Check if any air leakage is found through the exhaust port of the rear cover when the foot valve has been depressed.
 2. Check if exhaust will be performed immediately when the foot valve has been released.

- Disassembly:**
1. Disconnect M6 x 18 bolt and then remove the rear cover.
 2. Pull the exhaust valve out of the rear cover.

FOOT PEDAL









- Check:**
1. Check if any air leakage is found when it is not depressed.
 2. Check if any air leakage is found when it has been depressed.
 3. Check if air suction or air exhaust will be performed immediately and securely during the repetition of pressing and releasing.

- Disassembly:**
1. Stop the air supply.
 2. Pull off the hinge shaft of the valve case by disconnecting the E-3 snap ring.
 3. Disconnect the small M3 x 8 screw setting the valve block with a phillips head screw driver.
 4. Pull out the spring pin (2mm²) setting the push-pin on the valve block and take out the push-pin, coil spring, washer, and O-ring.
(Note: In case any air leakage is found when the foot pedal has been pressed or the performance of the foot valve is wrong, check if the push-pin, coil spring, and O-ring are not damaged and properly lubricated).
 5. Remove the spring-holding bushes on the both sides of the valve block and then take out the coil spring and the ball made of polyurethane respectively.
(Note: In case air leakage is found only when the foot valve is not pressed, remove the spring-holding bush on the side of taking the compressed air and then replace the ball with new one or rinse the ball clearly.
In case that leakage is found only when the foot pedal has been pressed, remove the spring-holding bush on the side of connecting the main body thereto and then replace the ball with new one or rinse the ball clearly).

How to handle O-ring, packing, and ball made of polyurethane

1. Be sure to check carefully on their disassembly if they are damaged or worn.
(Note : Most of the causes of the dropping of performance such as air leakage etc. are due to wearing or damage of the parts shown above).
2. Be sure to use light oil or alcohol etc. for rinsing the parts.
(Note : Never to use toluene, thinner, and gasoline etc. for the rinsing because it will corrode the parts).
3. Be careful on their handling for disassembly and assembly lest any parts should be damaged.
4. Be sure to apply proper grease on the grooves and all their surfaces prior to their assembly and take care not to allow any dust to stick on them.

OPTION

				TE P/N
No.1 head	1.25~5.5mm ²	Non-insulated		2155365-1
No.3 head	1.25mm ²	Insulated	 	2155365-2
No.4 head	2mm ²	Insulated	 	2155365-3
No.5 head	5.5mm ²	Insulated		2155365-4
No.7A head	CE-2, CE-5	Closed end		2155365-5
No.8 head	CE-1, CE-8	Closed end		2155365-6

NOTE

 For the crimp terminals of JIS C 2805 and JIS C 2806.
(JIS: Japanese Industrial Standards)
It has not applied to the TE terminal.

 For the crimp terminals of JIS C 2807.
(JIS: Japanese Industrial Standards)
It has not applied to the TE terminal.

 Since it may change with terminal makers, please introduce a use terminal maker when placing an order.

この取扱説明書は本機の取り扱い、注意事項などについて説明してありますのでご使用前によくお読みのうえ、正しく安全にご使用ください。

目次

安全上の注意事項	12 of 17
リブリーケーション・ユニット	12 of 17
工具仕様	12 of 17
各部の名称	13 of 17
使用方法	14 of 17
AF-2 フットペダル圧着保持時間の調整方法	14 of 17
交換用ヘッドの着脱方法	15 of 17
交換用ヘッド オプション別売り	15 of 17
保守・点検	16 of 17
パーツリスト	17 of 17

・安全上の注意事項

- (1) ヘッド交換の際は必ず空気源を止めてから行なって下さい。
- (2) 空押し操作はできるだけさけて下さい。
- (3) ヘッド部は瞬間的な作動をしますので手元には十分注意して下さい。
- (4) 圧着保持の時間調整ねじを右回転(時計方向)へ締め込み過ぎて操作するとヘッド部が解除しなくなります。この場合すみやかに調整ねじを左回転(反時計方向)へゆるめて下さい。所定位置に達するとヘッドは自動解除します。
- (5) 危険防止のため0.6MPaを超える空気圧では使用しないで下さい。
- (6) 始業前に必ず軸(63)および交換用ヘッドの支点軸への注油を行って下さい。

・リューブリケーション・ユニット

フィルタ・オイラ・レギュレータ・圧力計がセットされておりますので、このセットを空気ホースの途中に設けますと一定圧の清浄な空気と潤滑油を自動的に供給出来ますので、圧力オーバーによる工具の破損を防ぐばかりでなく工具が大変長持ち致します。

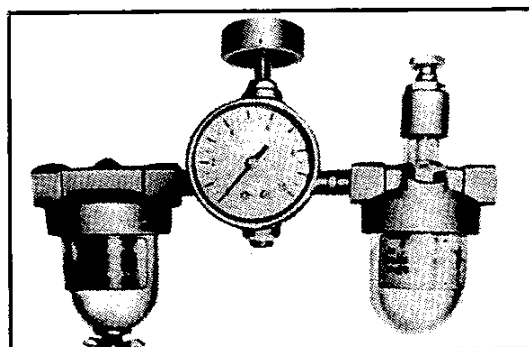

・工具仕様

項目	内容
動力形式	〈ピストン往復動〉+〈リンク機構〉
使用空気圧力	0.5~0.6MPa(ゲージ圧)
公称出力	12.5kN(空気圧0.5MPa時)
操作方式	足踏み操作に依るフットバルブの開閉
本体寸法・重量	長さ190mm×高さ99mm×巾92mm・2.0kg
使用ホース	耐圧1.0MPa(PT1/4口金付)
消費空気量	33ℓ/min(空気圧0.6MPaにて毎分30回使用時の大気量)
圧着能力 (ヘッド交換を要す)	裸圧着端子・スリーブ } 1.25~5.5mm ² 絶縁被覆付圧着端子・スリーブ } 閉端接続子 CE-1~CE-8
標準付属品	AF-2フットペダル(2mエアホース2本付)

・各部の名称

■ TE AC-5ND 本体

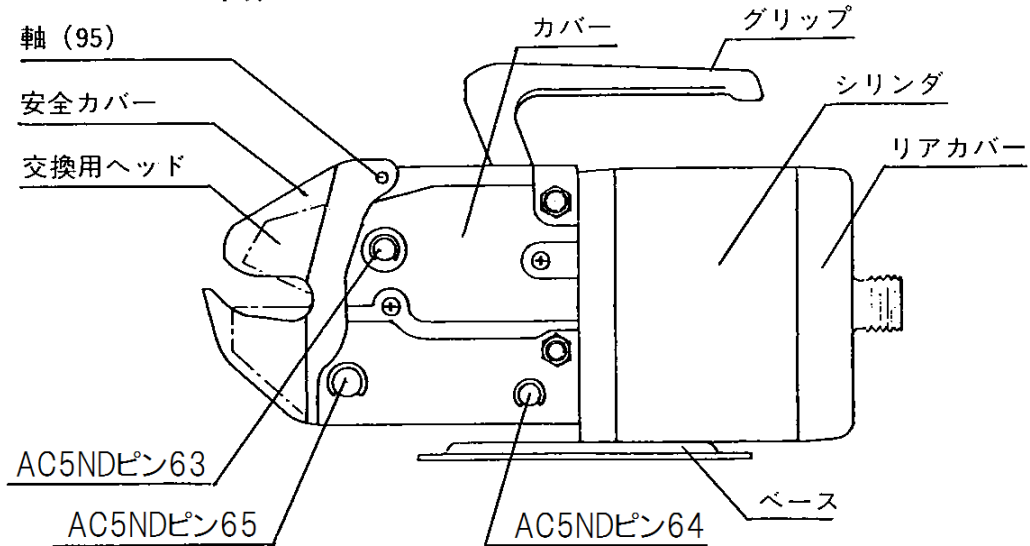

■ AF-2 フットペダル (空気圧保持機構バルブ内蔵型)

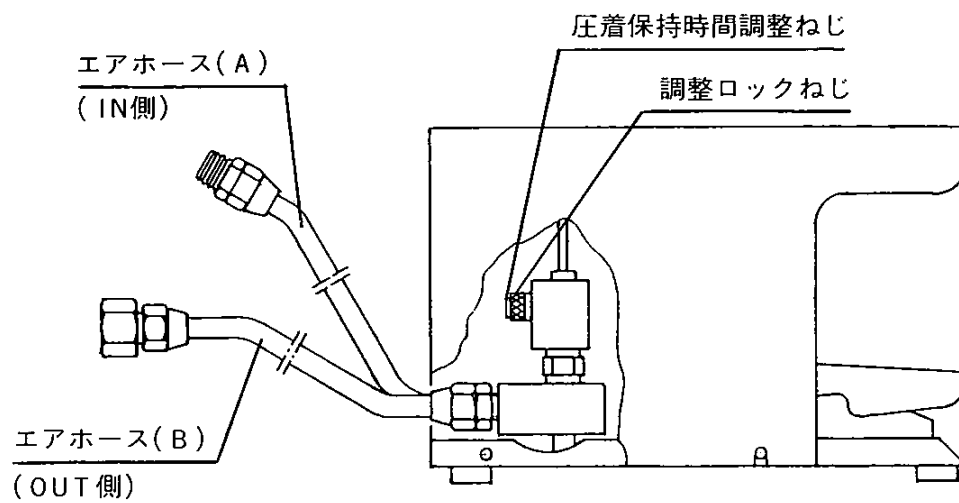

・使用方法

- (1)ヘッ드의取付け……………電線サイズと端子の種別に合ったダイスを装着して下さい。〔着脱の方法は4ページ参照〕
- (2)空気圧の調整……………使用する端子に応じて空気圧を0.5～0.6MPaの範囲内で調節して下さい。空気圧が範囲外ですと本機の機能及び寿命に影響しますので使用中にも時々チェックして下さい。
- (3)ドレーンの除去……………本機内にドレーンが入りますと発錆の原因となり、機能を低下させ寿命を縮めますので、配管の途中にはドレーン抜きを設けてご使用前には必ずドレーン除去して下さい。
- (4)各部への給油……………各軸及びリンク部には注油口より、又シリンダ内にはホース取付口よりそれぞれスピンドル油を時々注油して下さい。但し、リューブリケーション・ユニットを使用している場合はシリンダ内への給油は不要です。
- (5)エアホースの取付け…付属のフットバルブに取付けられている2本のホースの内、袋ナット〔PF 3/8″〕の付いている方を本体に、もう一方〔PT 1/4″オネジ〕を圧搾空気取出口に取付けて下さい。
- (6)圧着作業……………両手で端子と電線を適合菌形の箇所保持し手元に十分注意して、フットペダルを「ポン」と踏み込んで下さい。端子の圧着をより確実にコントロールし、圧着不足を防止するために一定の保持時間にセットしてありますので、圧着終了と同時にダイスは自動解除し、次の作業に移れます。

・AF-2 フットペダル圧着保持時間の調整方法

(空気圧保持機構バルブ内蔵型)

〔本フットペダルはフットペダルの踏む時間に関係なく一定の圧着保持時間をエアタイマーにより、常に確保致しますので作業者の個人差に関係なく常に正確な圧着が出来ることを目的としています。〕

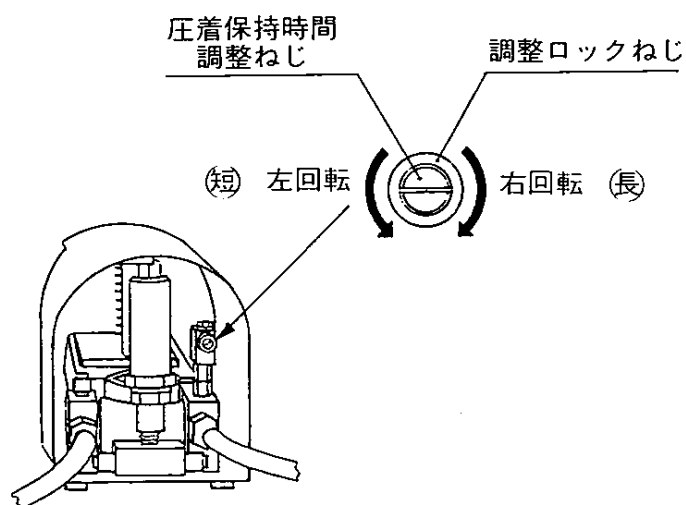

- (1)調整ロックねじを左回転（反時計方向）させてゆるめます。
 - (2)圧着保持時間調整ねじをドライバー（-）にて右、左回転任意の方向へ回転させます。
 - 右回転——保持時間が長くなる
 - 左回転——保持時間が短くなる
- 作業用途に応じた時間設定が完了したら調整ロックねじにて右回転（時計方向）させ締付けます。

・交換用ヘッドの着脱方法

〔取付け〕 ヘッドを本体の所定位置に挿入し
AC5NDピン64 → AC5NDピン63
→ AC5NDピン65 の順に図示方向
よりストップリングが取付面に当
るまで差込んで下さい。(キツイ
場合は軸に棒等を当てハンマでた
たいて下さい。)

〔差込が不完全ですと軸の抜け落
ち等により工具を損傷すること
があります。〕

〔取外し〕 各軸は図示反対側より押すと抜け
ます。(キツイ場合は軸に棒等を当
てハンマでたたいて下さい。) 尚、
外す順序は取付け時と同様、
AC5NDピン64 → AC5NDピン63
→ AC5NDピン65 の順に行なって下
さい。

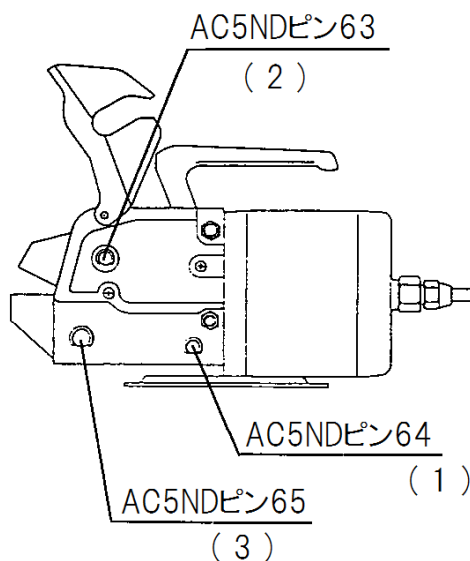

注記

- ・取付け時に各 AC5ND ピンのストップリングが穴端面(取付面)に当たるまで確実に差し込んでください。
- ・AC5ND ピンに変形、外傷、抜けてくるなどの症状がある場合は AC5ND ピンを交換してください。

・交換用ヘッド オプション別売り

				TE P/N
1号ヘッド	1.25~5.5mm ²	Non-insulated	裸圧着端子、スリーブ	△1 2155365-1
3号ヘッド	1.25mm ²	Insulated	絶縁被覆付圧着端子、スリーブ	△1 △3 2155365-2
4号ヘッド	2mm ²	Insulated	絶縁被覆付圧着端子、スリーブ	△1 △3 2155365-3
5号ヘッド	5.5mm ²	Insulated	絶縁被覆付圧着端子、スリーブ	△1 2155365-4
7号Aヘッド	CE-2, CE-5	Closed end	絶縁被覆付閉端接続子	△2 2155365-5
8号ヘッド	CE-1, CE-8	Closed end	絶縁被覆付閉端接続子	△2 2155365-6

注記



JIS C 2805 (銅線用裸圧着端子、銅線用絶縁被覆付圧着端子)、
JIS C 2806 (銅線用裸圧着スリーブ) に基づく圧着接続用。
TE 製の端子には適用していません。



JIS C 2807 (絶縁被覆付閉端接続子) に基づく圧着接続用。
TE 製の端子には適用していません。



端子メーカーによって異なる場合がありますので、ご注文に際しては使用端子メーカーを
ご紹介下さい。

・ 保守・点検

日常の保守・点検を怠りますと工具の故障の原因になります。

次の事項に十分注意して下さい。

- (1) 工具の円滑な作動及び、サビの発生を防ぐためできるだけ湿気をさけて保管して下さい。
- (2) スピンドル油を各 AC5ND ピンに注油、又リンク部には注油口より注油、シリンダ内には、リアカバー部のホース取付け口より時々注油してください。
交換用ヘッドの支点軸への注油も行ってください。

アルミカバーの注油口

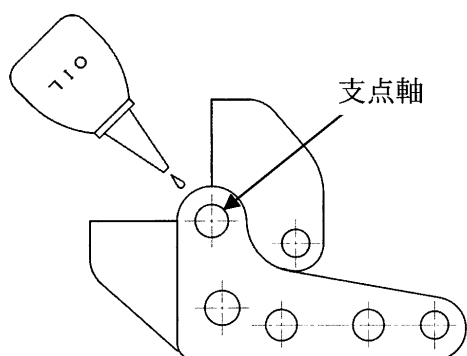
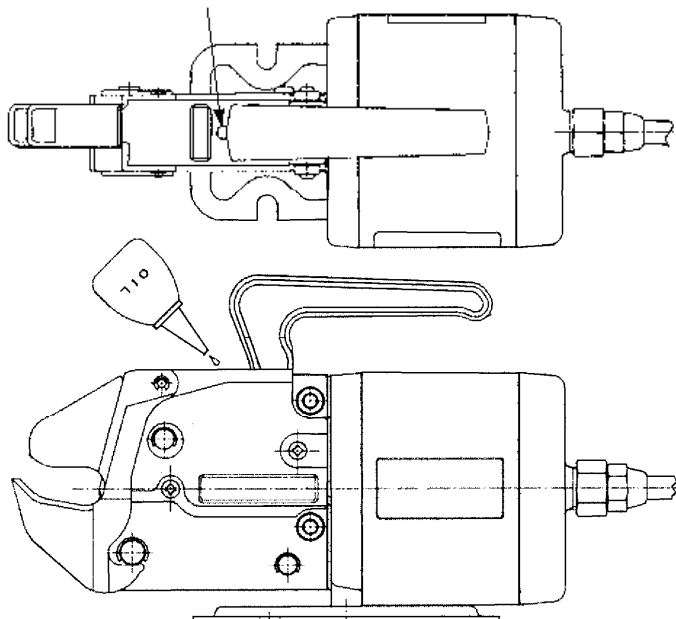

交換ヘッド

- (3) エアホースは、折り曲げたり、踏みつけたりしない様、取り扱い保管して下さい。
- (4) 故障が生じた場合は、もよりの代理店又は、営業所へお問い合わせ下さい。

・パーツリスト

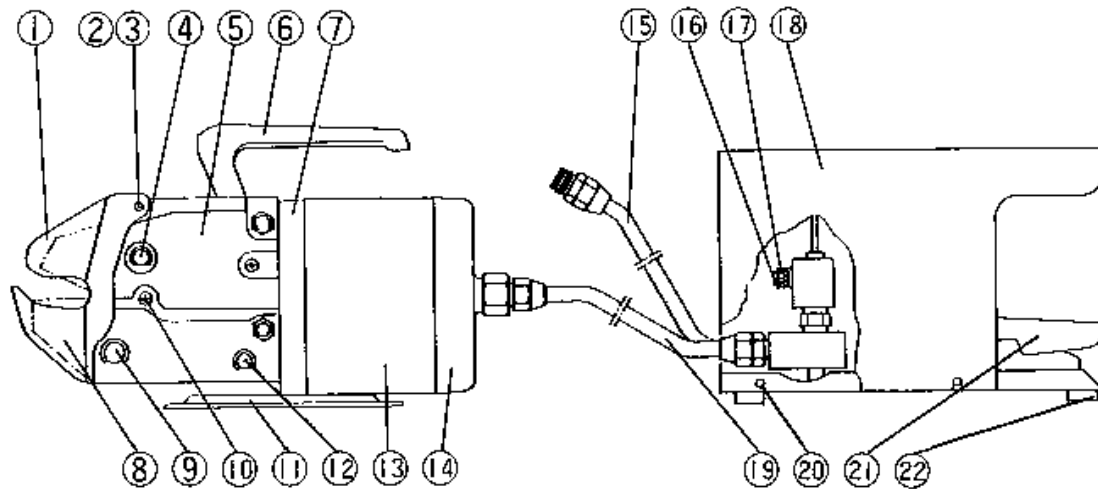

番号	品名	# 型番	番号	品名	# 型番
1	安全カバー		12	* AC5NDピン64	# 2155364-3
2	軸 (95)		13	シリンダ	
3	E型止め輪 2.5		14	リアカバー	
4	* AC5NDピン63	# 2155364-2	15	エアホース (A)	
5	カバ ー		16	圧着保持時間調整ねじ	
6	グリップ		17	調整ロックねじ	
7	フロントカバー		18	フットペダルカバー	
8	交換用ヘッド		19	エアホース (B)	
9	* AC5NDピン65	# 2155364-4	20	十字穴付なべ小ねじ M5×6	
10	十字穴付なべ小ねじ M4×6		21	フットペダル	
11	ベ ー ス		22	ゴ ム 足	

* ピンにはストップリング (OEリング)が付属しています。