

Ultra-Low-THD Dual-SPDT (0.35Ω) Analog Switch with Negative Signal Handling Capability

Features

- CMOS Technology for Bus and Analog Applications
- Negative Signal Handling Capability at all Ports
- Low On-Resistance: 0.35Ω at 1.8V Supply
- On-Resistance Flatness 0.001Ω
- Wide VDD Range: 1.65V to 4.3V
- 2.0Vrms analog signal range
- Programmable soft-start and soft-stop time
- -3dB Bandwidth: 255MHz
- High Off Isolation: -85dB @ 30kHz
- Low THD: 0.0003% from 20Hz to 20kHz, 0.5VRMS
- Crosstalk Rejection Reduces Signal Distortion: -85dB @ 30kHz
- High-impedance mode when VDD not applied
- ESD: 4kV for HBM mode, 1kV for CDM mode
- Extended Industrial Temperature Range: -40°C to 85°C
- Totally Lead-Free & Fully RoHS Compliant (Notes 1 & 2)
- Halogen and Antimony Free. "Green" Device (Note 3)
- Packaging (Pb-free & Green): -10-contact UQFN (ZM10)

Applications

- Cell Phones, PDAs, MP3 Players
- Portable Instrumentation
- Computer Peripherals
- Speaker Headset Switching
- Power Routing
- Relay Replacement
- Audio and Video Signal Routing
- PCMCIA Cards
- Modems

Description

PI3A288 is a dual, single-pole double throw (SPDT) CMOS switch with negative signal handling capability at all ports. It can be used as an analog switch or as a low-delay bus switch. Operating over a wide power supply voltage ranges from 1.65V to 4.3V, PI3A288 processes a low on-resistance and distortion. The ultra-low THD performance enables PI3A288 to apply in high-quality audio applications. PI3A288 has also a soft-start and soft-stop feature so as to minimize signal disruption during channel switching.

Functional Block Diagram

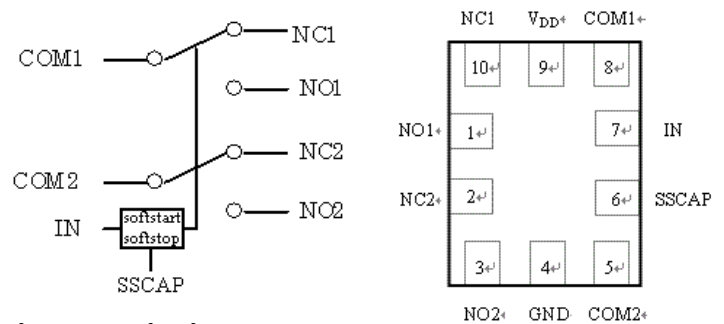

Pin Description

Pin	Name	Description
1, 3	NO _X	Data Ports (Normally open)
4	GND	Ground
2, 10	NC _X	Data Ports (Normally closed)
5, 8	COM _X	Common Output / Data Ports
9	V _{DD}	Positive Power Supply
7	IN	Logic Control Pins
6	SSCAP	Slew Rate Control Pin

Logic Function Table

Logic Input (IN)	Function
0	NC1 Connected to COM1 NC2 Connected to COM2
1	NO1 Connected to COM1 NO2 Connected to COM2

Notes:
 1. No purposely added lead. Fully EU Directive 2002/95/EC (RoHS), 2011/65/EU (RoHS 2) & 2015/863/EU (RoHS 3) compliant.
 2. See <https://www.diodes.com/quality/lead-free/> for more information about Diodes Incorporated's definitions of Halogen- and Antimony-free, "Green" and Lead-free.
 3. Halogen- and Antimony-free "Green" products are defined as those which contain <900ppm bromine, <900ppm chlorine (<1500ppm total Br + Cl) and <1000ppm antimony compounds.

Maximum Ratings

Storage Temperature.....	-65°C to +150°C
Ambient Temperature with Power Applied.....	-40°C to +85°C
Supply Voltage V_{DD}	-0.5V to +4.6V
Control Input Voltage V_{IN}	-0.5V to +4.6V
DC Input Voltage V_{INPUT}	$V_{DD} - 6.0V$ and $-3.1V$ to $+3.1V$
Continuous Current NO_NC_COM_.....	$\pm 350mA$
Peak Current NO_NC_COM_	
(pulsed at 1ms 50% duty cycle)	$\pm 400mA$
Peak Current NO_NC_COM_	
(pulsed at 1ms 10% duty cycle)	$\pm 500mA$
ESD HBM mode.....	4kV
CDM mode.....	1kV

Note:

Stresses greater than those listed under MAXIMUM RATINGS may cause permanent damage to the device. This is a stress rating only and functional operation of the device at these or any other conditions above those indicated in the operational sections of this specification is not implied. Exposure to absolute maximum rating conditions for extended periods may affect reliability.

Control input must be held HIGH or LOW; it must not float.

Recommended Operating Conditions

Symbol	Parameter	Conditions	Min.	Typ.	Max.	Unit
V_{DD}	Operating Voltage	-	1.65	-	4.3	V
V_{IN}	Control Input Voltage	-	0	-	4.3	V
V_{INPUT}	Switch Input Voltage	$V_{DD} \leq 2.3V$		2.0		V_{RMS}
		$V_{DD} > 2.3V$		1.8		
T_A	Operating Temperature	-	-40	25	85	°C

Electrical Characteristics

($T_A = -40^\circ C$ to $85^\circ C$, unless otherwise noted. Typical values are at 1.8V and $+25^\circ C$.)

Parameter	Symbol	Test Conditions	Min.	Typ.	Max.	Units	
ANALOG SWITCH							
Analog Signal Range	V_{NO} , V_{NC} , V_{COM}	$V_{DD} \leq 2.3V$		2.0		V_{RMS}	
		$V_{DD} > 2.3V$		1.8			
On-Resistance	R_{ON}	$V_{DD} = 1.8V$, $V_{COM} = 0V$ Test Circuit Figure 1	-	0.35	-	Ω	
On-Resistance Match Between Channels	ΔR_{ON}	$V_{DD} = 1.8V$, $V_{COM} = 0V$ between same NC_ and NO_ channel Test Circuit Figure 1	-	0.005	0.05	Ω	
On-Resistance Flatness	R_{ONF}	$V_{DD} = 1.8V$, $V_{COM} = -2.5V$ to $+2.5V$ Test Circuit Figure 1 (NOTE1)		0.001	0.01	Ω	
Supply Current	I_{CC}	$V_{DD} = 1.8V$	-	70	110	μA	
DIGITAL INPUTS							
Input Logic High	V_{IH}		1.4			V	
Input Logic Low	V_{IL}				0.325		
IN Input Leakage Current	I_{IN}	$V_{DD} = 1.8V$, $V_{IN} = 0$ or $1.8V$	-0.5	-	0.5	μA	
DYNAMIC CHARACTERISTICS							
Turn-Off Time	t_{OFF}	V_{NO} or $V_{NC} = 3V$, $R_L = 32\Omega$ SSCAP=float		65		μs	
Turn-On Time	t_{ON}	V_{NO} or $V_{NC} = 3V$, $R_L = 32\Omega$ SSCAP=float		270		μs	
Soft-Start Time	t_{START}	SSCAP=0.01 μF $V_{NC} = 0.1V$, 10% to 90%		5		ms	
Soft-Stop Time	t_{STOP}	SSCAP=0.01 μF $V_{NC} = 0.1V$, 90% to 10%		5		ms	
NC-NO and COM-NC/NO Off-Isolation	O_{ISO}	$V_{BIAS} = 0V$, $V_{IN} = 0dBm$ See Test Circuit Figure 2 and Figure 3	30kHz	-	-85	-	dB

Channel-to-Channel Crosstalk	X_{TALKD}	$V_{BIAS}=0V, V_{IN}=0dBm$ See Test Circuit Figure 4	30kHz	-	-85	-	dB
-3dB Bandwidth	f_{3dB}	$V_{BIAS}=0V, V_{IN}=0dBm$ See Test Circuit Figure 5		-	255	-	MHz
Total Harmonic Distortion	THD+N	$f=20Hz$ to $20kHz, R_L=32\Omega,$ $V_{IN}=0.5V_{RMS}, V_{BIAS}=0V$ (NOTE2)		-	-110	-	dB

Note 1 and Note 2 : These parameters are measured on TA=25°C

Capacitance

Parameter	Symbol	Test Conditions	Min.	Typ.	Max.	Units
Control Pin Input Capacitance	C_{IN}	$V_{DD}=0V, f=1MHz,$	-	6	-	pF
NC Off Capacitance	$C_{NC(OFF)}$	$V_{DD}=1.8V, f=1MHz,$ See Test Circuit Figure 6.	-	14	-	
NO Off Capacitance	$C_{NO(OFF)}$	$V_{DD}=1.8V, f=1MHz,$ See Test Circuit Figure 6.	-	14	-	
NC On Capacitance	$C_{NC(ON)}$	$V_{DD}=1.8V, f=1MHz,$ See Test Circuit Figure 7.	-	35	-	
NO On Capacitance	$C_{NO(ON)}$	$V_{DD}=1.8V, f=1MHz,$ See Test Circuit Figure 7.	-	35	-	

Test Circuits and Timing Diagrams

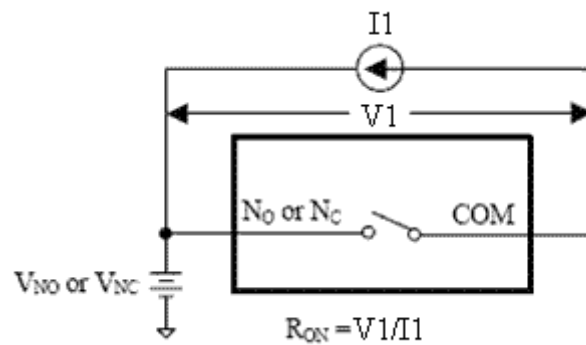

Figure 1, On Resistance

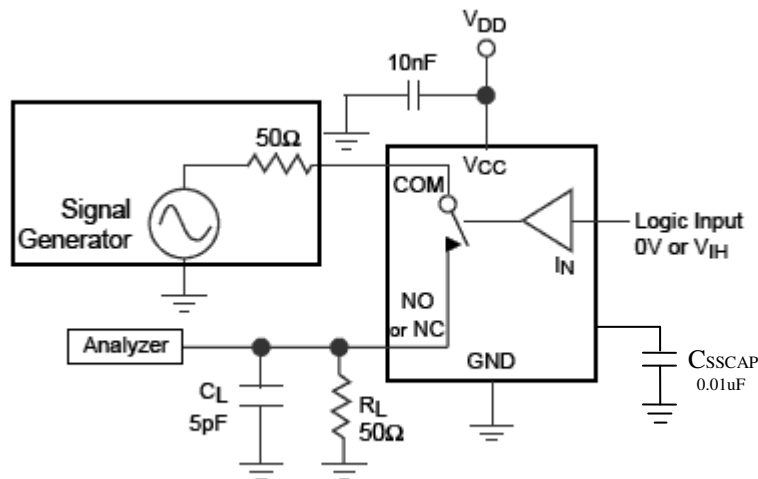

Figure 2, COM-NC/NO Isolation

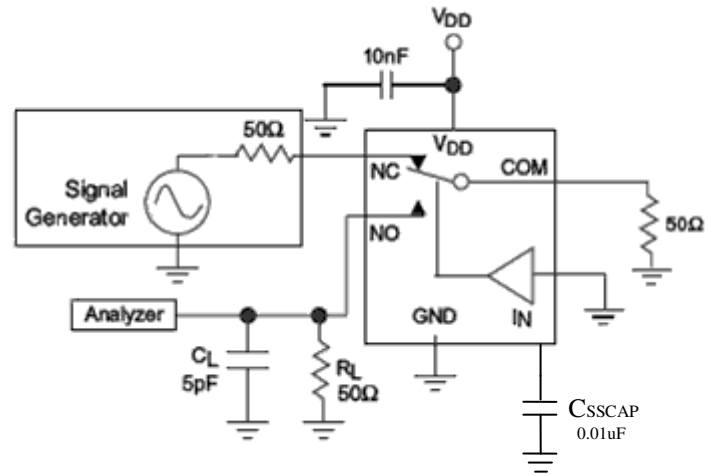

Figure 3, NC-NO Isolation

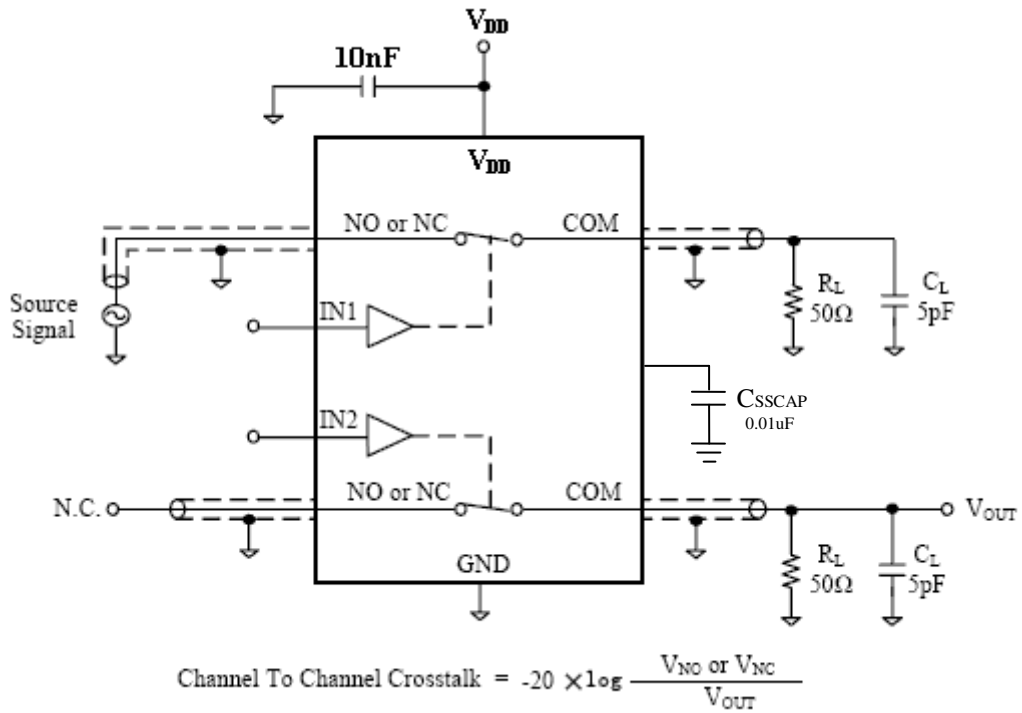

Figure 4, Channel-to-Channel Crosstalk

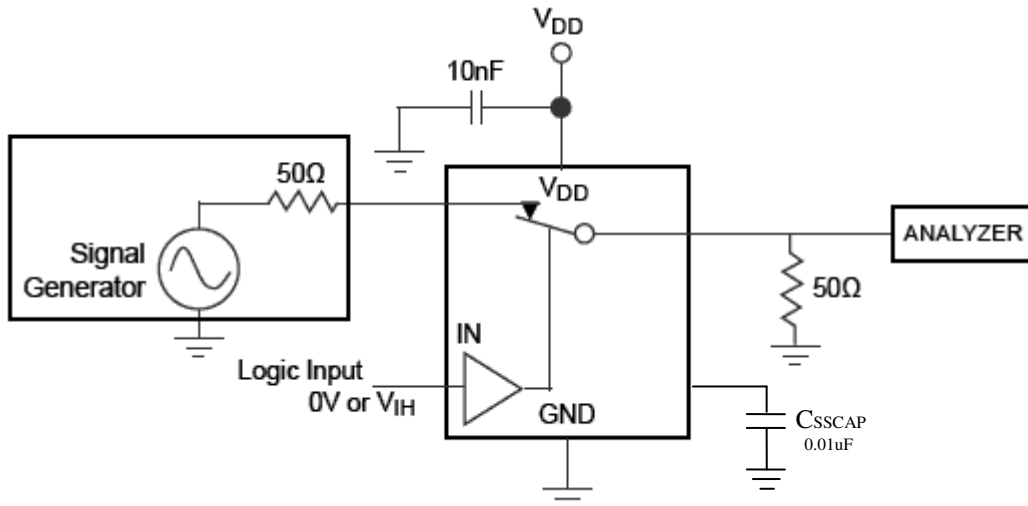

Figure 5, Bandwidth

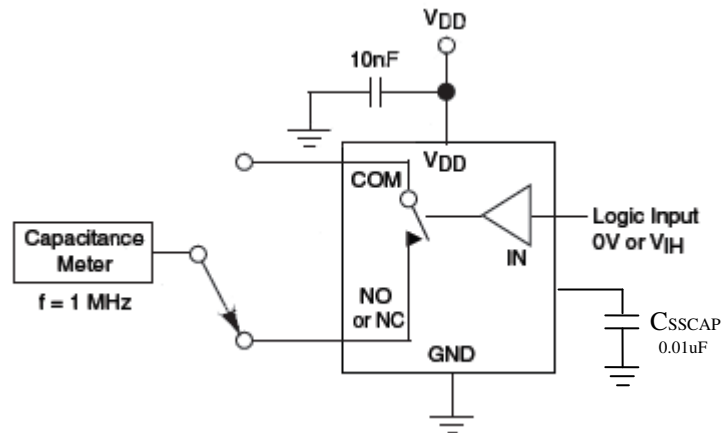

Figure 6, Channel Off Capacitance

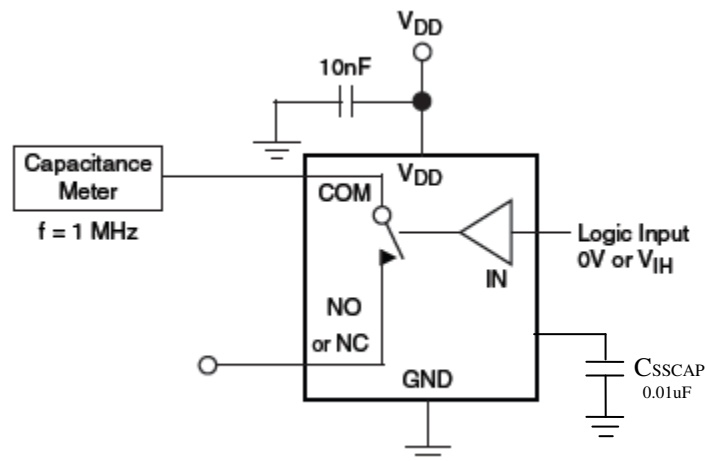

Figure 7, Channel On Capacitance

Typical Characteristics

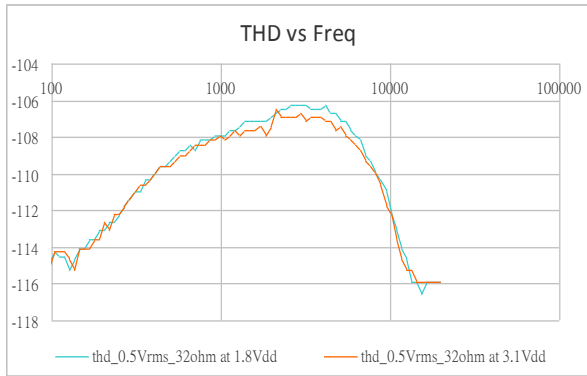

Figure 8, THD vs signal frequency

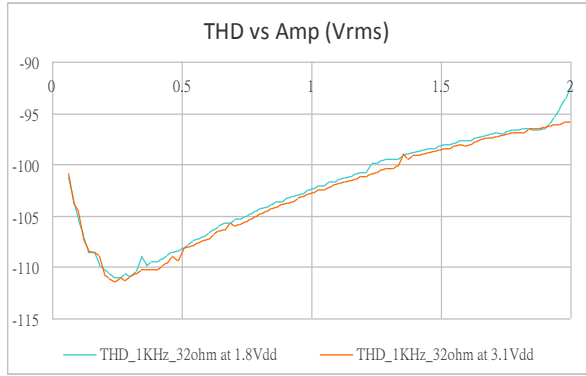

Figure 9, THD vs signal amplitude

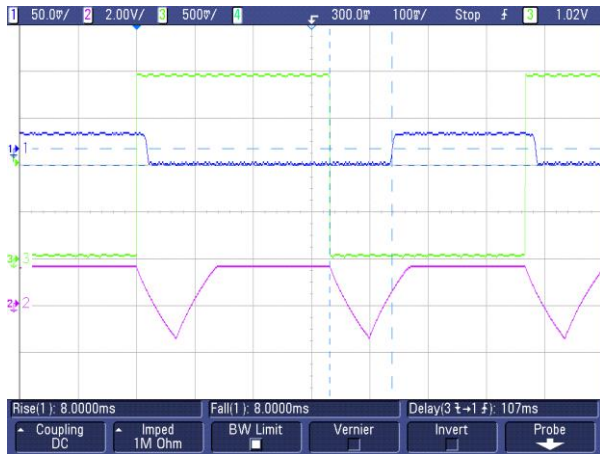

Figure 10, Soft-start with $C_{SSCAP} = 10nF$, $V_{NC} = +50mV$, $V_{NO} = 0V$
Channel 1 = COM
Channel 2 = SSCAP
Channel 3 = IN

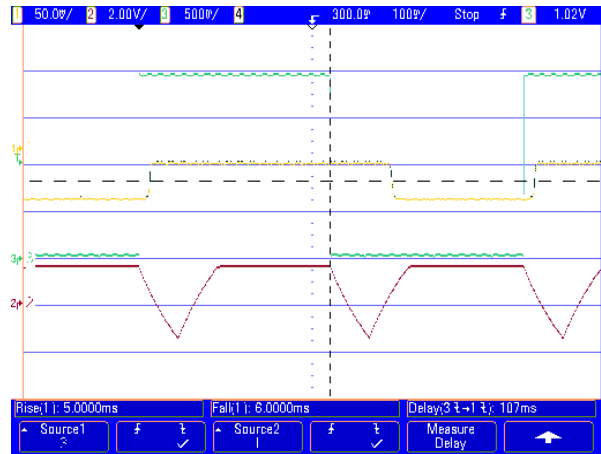

Figure 11, Soft-start with $C_{SSCAP} = 10nF$, $V_{NC} = -50mV$, $V_{NO} = 0V$
Channel 1 = COM
Channel 2 = SSCAP
Channel 3 = IN

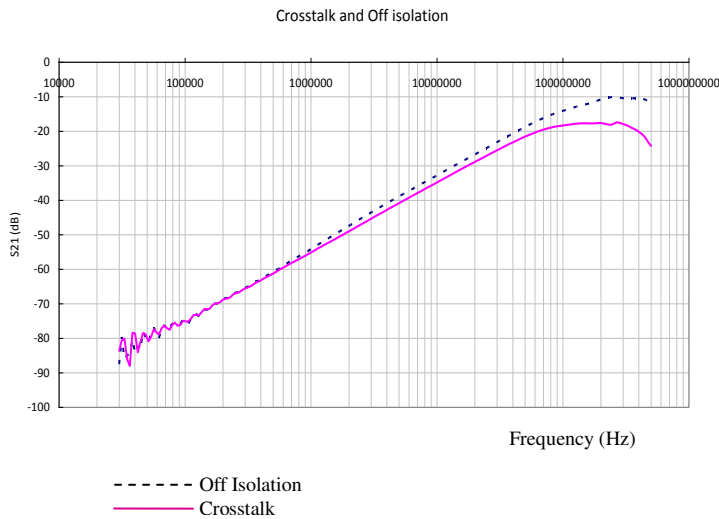

Figure12, Crosstalk and Isolation

Typical Application Circuit

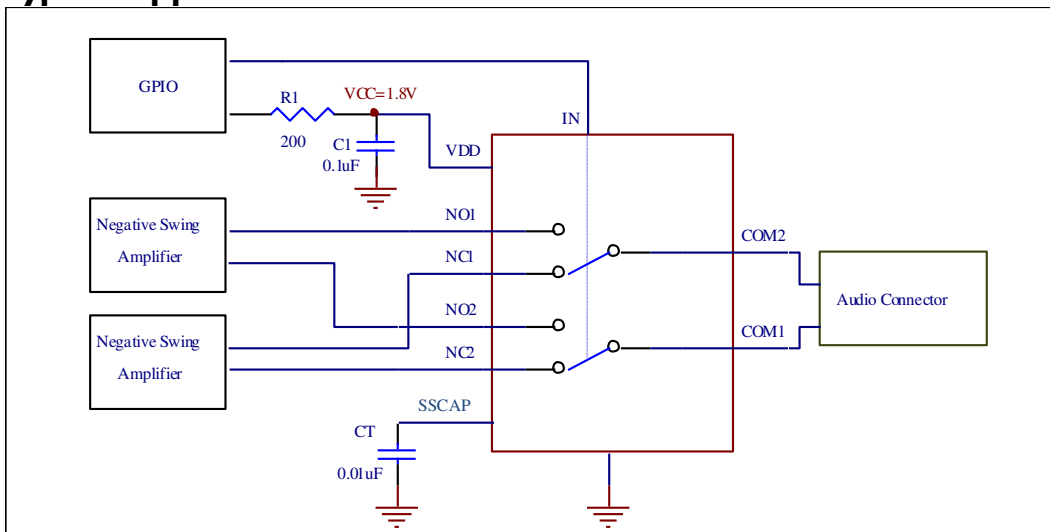

Figure12, Crosstalk and Isolation

Function Description

The PI3A288 is an ultra-small, ultra-low THD, low on-resistance, high ESD-protected DPDT switch that operates from a +1.65V to 4.3V supply. These switches feature the low on-resistance (RON) necessary for high-performance switching applications. The Beyond-the-Rails signal capability of the PI3A288 allows signals below ground and above VCC to pass without distortion.

Analog Signal Levels

The topology of the switches allows the signal to drop below ground without the need of an external negative voltage supply. The devices can also withstand analog signal levels of 2Vrms. in the case of lower VDD voltage.

Digital Control Input

The PI3A288 provides a single-bit control logic input, IN. IN controls the switch position. The logic control inputs can be driven up to +4.3V regardless of the supply voltage. For example, given a +3.3V supply, the output enables or select pins may be driven to low to 0V and high to 4.3V.

Click and Pop Operation

The PI3A288 can pass ground referenced audio signals which allows it to be directly connected to audio drivers that output ground referenced audio signals, eliminating the need for a DC blocking capacitor. Audio drivers that swing around ground, however, do generate some DC offset, from a few millivolts to tens of millivolts. When switching between audio channels or muting the audio signal, these small DC offset levels of the drivers can lead to a voltage step across the speaker loads and create unwanted clicks and pops.

The PI3A288 has a special soft-start feature that slowly ramps the DC offset voltage from the audio driver to the speaker load when turning on a switch channel. The ramp rate at the load is determined by the capacitor value connected at the SSCAP pin. A soft-start capacitor value of 0.01 μ F provides obvious effect of eliminating pop-click noise and is recommended.

Part Marking

ZM Package



YW: Year & Workweek

Packaging Mechanical
10- UQFN (ZM10)

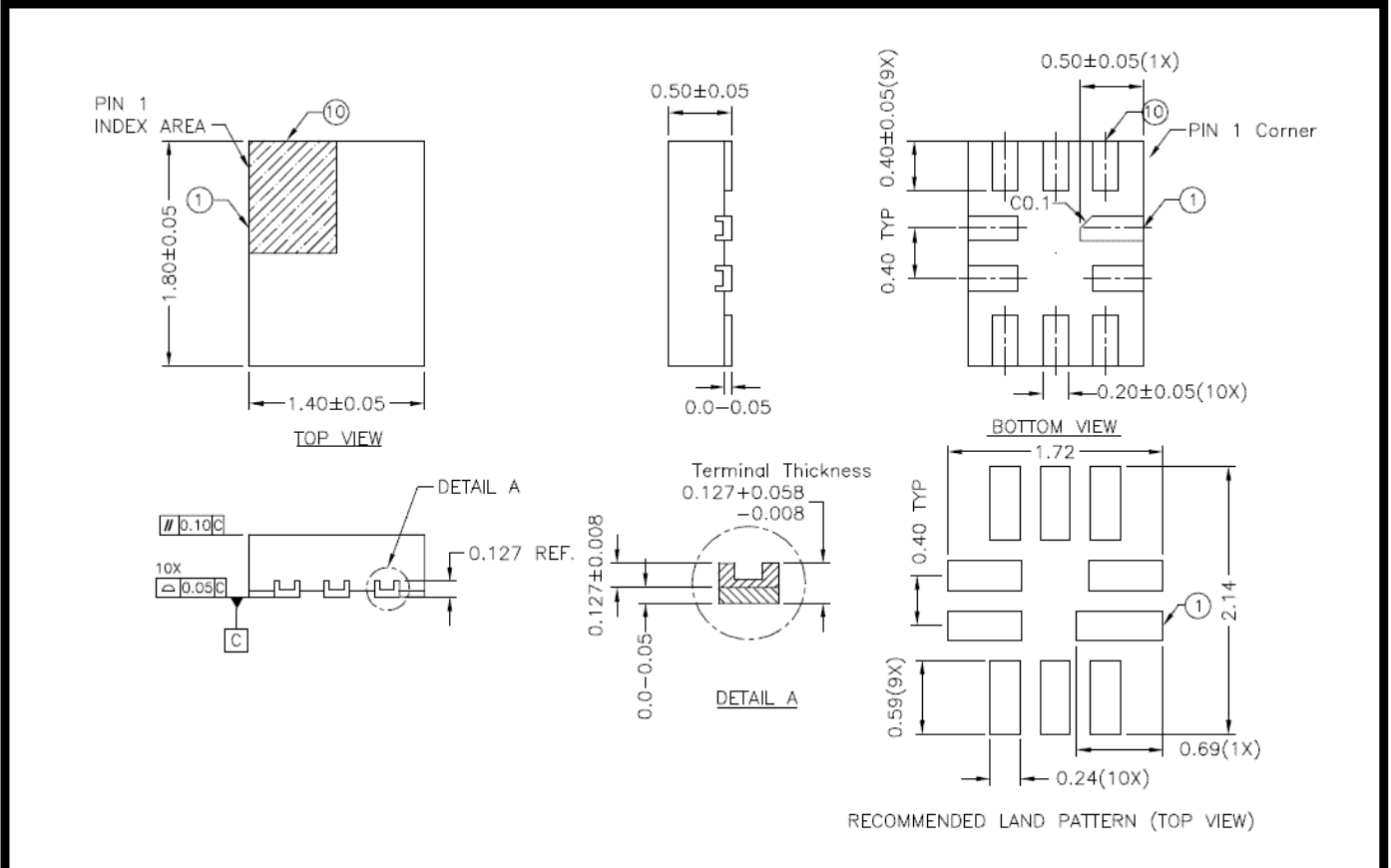

NOTE :

1. ALL DIMENSIONS ARE IN mm. ANGLES IN DEGREES.
2. COPLANARITY APPLIES TO THE EXPOSED PAD AS WELL AS THE TERMINALS.
3. REFER JEDEC MO-236/MO-248
4. RECOMMENDED LAND PATTERN IS FOR REFERENCE ONLY.

	DATE: 01/29/09
DESCRIPTION: 10-contact, Ultra-thin Quad Flat No-Lead (UQFN)	
PACKAGE CODE: ZM10	
DOCUMENT CONTROL #: PD-2066	REVISION: A

For latest package info.

please check: <http://www.diodes.com/design/support/packaging/pericom-packaging/packaging-mechanicals-and-thermal-characteristics/>

Ordering Information

Part Numbers	Package Code	Package
PI3A288ZMEX	ZM	10-contact, Ultra-thin Quad Flat No-Lead (UQFN)

Notes:

1. No purposely added lead. Fully EU Directive 2002/95/EC (RoHS), 2011/65/EU (RoHS 2) & 2015/863/EU (RoHS 3) compliant.
2. See <https://www.diodes.com/quality/lead-free/> for more information about Diodes Incorporated's definitions of Halogen- and Antimony-free, "Green" and Lead-free.
3. Halogen- and Antimony-free "Green" products are defined as those which contain <900ppm bromine, <900ppm chlorine (<1500ppm total Br + Cl) and <1000ppm antimony compounds.
4. E = Pb-free and Green
5. X suffix = Tape/Reel

IMPORTANT NOTICE

DIODES INCORPORATED MAKES NO WARRANTY OF ANY KIND, EXPRESS OR IMPLIED, WITH REGARDS TO THIS DOCUMENT, INCLUDING, BUT NOT LIMITED TO, THE IMPLIED WARRANTIES OF MERCHANTABILITY AND FITNESS FOR A PARTICULAR PURPOSE (AND THEIR EQUIVALENTS UNDER THE LAWS OF ANY JURISDICTION).

Diodes Incorporated and its subsidiaries reserve the right to make modifications, enhancements, improvements, corrections or other changes without further notice to this document and any product described herein. Diodes Incorporated does not assume any liability arising out of the application or use of this document or any product described herein; neither does Diodes Incorporated convey any license under its patent or trademark rights, nor the rights of others. Any Customer or user of this document or products described herein in such applications shall assume all risks of such use and will agree to hold Diodes Incorporated and all the companies whose products are represented on Diodes Incorporated website, harmless against all damages.

Diodes Incorporated does not warrant or accept any liability whatsoever in respect of any products purchased through unauthorized sales channel.

Should Customers purchase or use Diodes Incorporated products for any unintended or unauthorized application, Customers shall indemnify and hold Diodes Incorporated and its representatives harmless against all claims, damages, expenses, and attorney fees arising out of, directly or indirectly, any claim of personal injury or death associated with such unintended or unauthorized application.

Products described herein may be covered by one or more United States, international or foreign patents pending. Product names and markings noted herein may also be covered by one or more United States, international or foreign trademarks.

This document is written in English but may be translated into multiple languages for reference. Only the English version of this document is the final and determinative format released by Diodes Incorporated.

LIFE SUPPORT

Diodes Incorporated products are specifically not authorized for use as critical components in life support devices or systems without the express written approval of the Chief Executive Officer of Diodes Incorporated. As used herein:

A. Life support devices or systems are devices or systems which:

1. are intended to implant into the body, or
2. support or sustain life and whose failure to perform when properly used in accordance with instructions for use provided in the labeling can be reasonably expected to result in significant injury to the user.

B. A critical component is any component in a life support device or system whose failure to perform can be reasonably expected to cause the failure of the life support device or to affect its safety or effectiveness.

Customers represent that they have all necessary expertise in the safety and regulatory ramifications of their life support devices or systems, and acknowledge and agree that they are solely responsible for all legal, regulatory and safety-related requirements concerning their products and any use of Diodes Incorporated products in such safety-critical, life support devices or systems, notwithstanding any devices- or systems-related information or support that may be provided by Diodes Incorporated. Further, Customers must fully indemnify Diodes Incorporated and its representatives against any damages arising out of the use of Diodes Incorporated products in such safety-critical, life support devices or systems.

Copyright © 2016, Diodes Incorporated
www.diodes.com