

REVISIONS					
P.	LTN	DESCRIPTION	DATE	DMN	APVD
B1		REVISED DESIGN ECO-14-009564	16 JUL 2014	NCL	MG
B2		CHANGED NOTE 5 ECO-15-013698	23 SEP 2015	NCL	MG
C		REVISED BY ECO-18-017297	14 NOV 2018	EL	JMN
C1		REVISED BY ECO-19-005113	05 ABR 2019	LAA	DAO

SUPPLY CONDITION

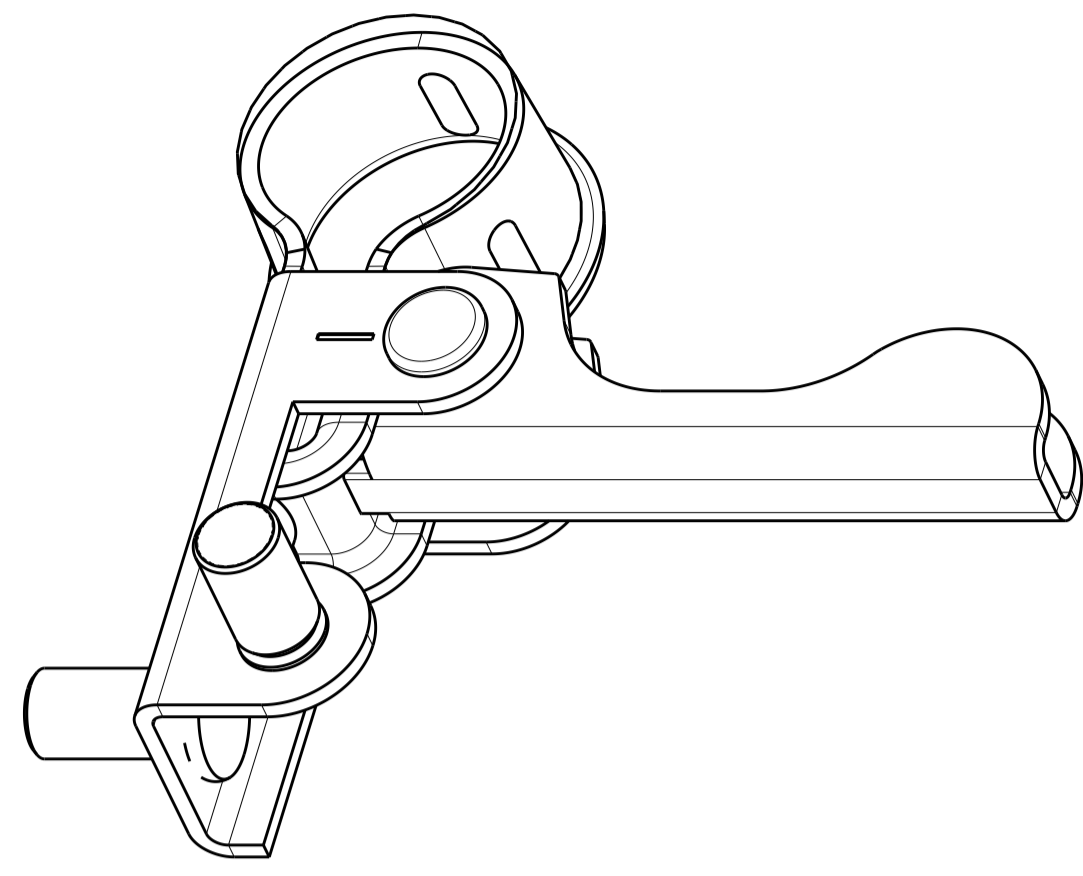

PERSPECTIVE VIEW
SCALE 2:1

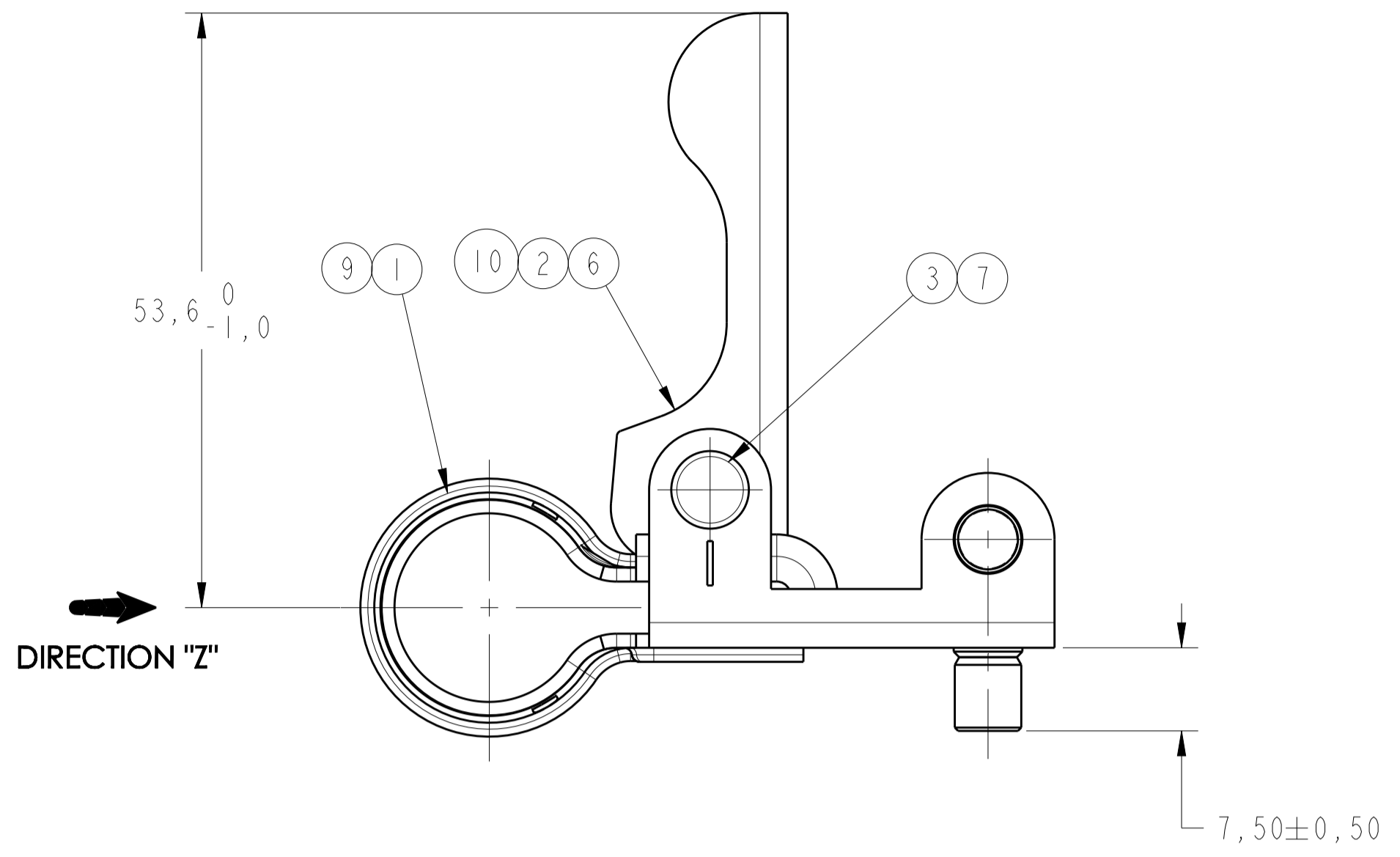

- 1 - LATÃO CuZn30 1/2 DURO CONFORME ESPECIFICAÇÃO TE 100-86 T082;
- 2 - ACABAMENTO PÓS-ESTANHADO COM ESPESSURA DE CAMADA DE 8µm A 15µm, CONFORME ESPECIFICAÇÃO TE 112-16-3;
- 3 - APÓS PRIMEIRO ACIONAMENTO DA ALAVANCA A DIMENSÃO DE Ø17,341 PODE CHEGAR A Ø17,041 MIN.
- 4 - TORQUE INDICADO PARA OS PARAFUSOS: 5.0±0.5 Nm
- 5 - TERMINAL PARA POLO DE BATERIA NEGATIVO CONFORME JCI
- 6 - DIMENSÃO DE REFERÊNCIA VÁLIDA SOMENTE NO BLANK
- 7 - ACABAMENTO ZINCADO CROMO TRIVALENTE AMARELO ELETRODEPOSITADO COM ESPESSURA DE CAMADA DE 8 A 15µm E CAMADA ORGÂNICA COMPLEMENTAR (SELANTE) CONFORME ESPECIFICAÇÃO TE 112-78-6; RESISTÊNCIA A CORROSÃO DO ACABAMENTO (CORROSÃO BRANCA) DE 120 HORAS E CORROSÃO DO METAL BASE (CORROSÃO VERMELHA) DE 240 HORAS CONFORME ESPECIFICAÇÃO GMW 3044
- 8 - ACABAMENTO ZINCADO BRANCO BICROMATIZADO TRIVALENTE ELETRODEPOSITADO COM ESPESSURA DE CAMADA DE 8 A 15µm. SALT SPRAY 96 HORAS CORROSÃO BRANCA.
- 9 - COBRE FERRO CuFe2P 1/2 DURO CONFORME ESPECIFICAÇÃO TE 100-265 H02;

- 1 - BRASS CuZn30 1/2 HARD ACC. TO SPEC. TE 100-86 T082;
- 2 - POST-TINNED PLATE, LAYER THICKNESS 8µm TO 15µm, ACC. TO SPEC. TE 112-16-3;
- 3 - AFTER FIRST ACTUATION OF LEVER THE DIMENSION Ø17,341 CAN BECOME Ø17,041 MIN.
- 4 - RECOMMENDED TORQUE AT THE SCREWS: 5.0±0.5 Nm
- 5 - TERMINAL TO NEGATIVE BATTERY POLE ACC. TO JCI
- 6 - REFERENCE DIMENSIOIS VALID ONLY FOR BLANK
- 7 - ZINC PLATE TRIVALENTE CHROMIUM YELLOW ELECTROPLATED WITH THICKNESS LAYER OF 8 TO 15 µm AND SUPPLEMENTAL ORGANIC TOPCOAT ACCORDING TE-112-78-6 SPECIFICATION; RESISTANCE TO PLATE CORROSION (WHITE CORROSION) OF 120 HOURS AND BASE METAL CORROSION (RED CORROSION) OF 240 HOURS ACCORDING SPECIFICATION
- 8 - ZINC PLATE BICROMATIZED TRIVALENTE WHITE ELECTROPLATED WITH LAYER THICKNESS OF 8 TO 15µm SALT SPRAY 96 HOURS WHITE CORROSION
- 9 - IRON COOPER CuFe 1/2 HARD ACC. TO SPEC. TE 100-265 H02;

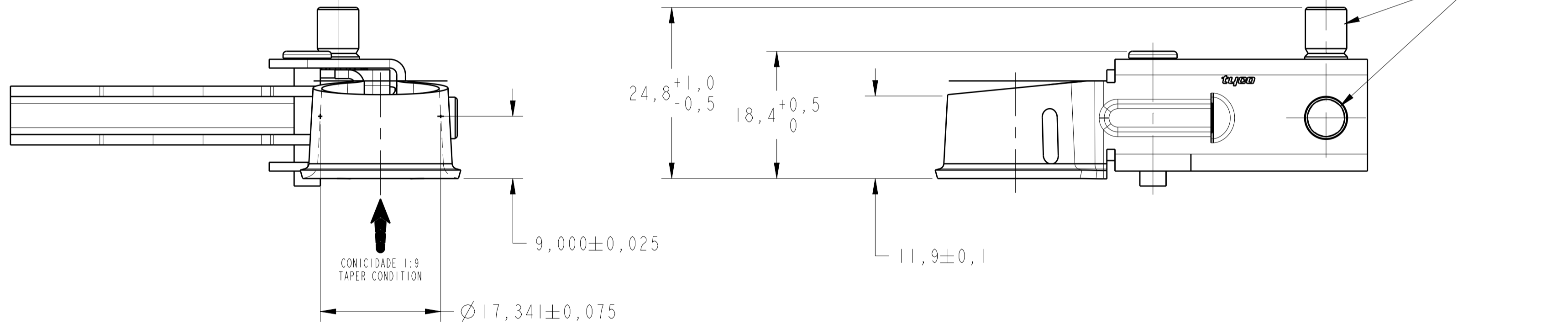

FINAL CONDITION

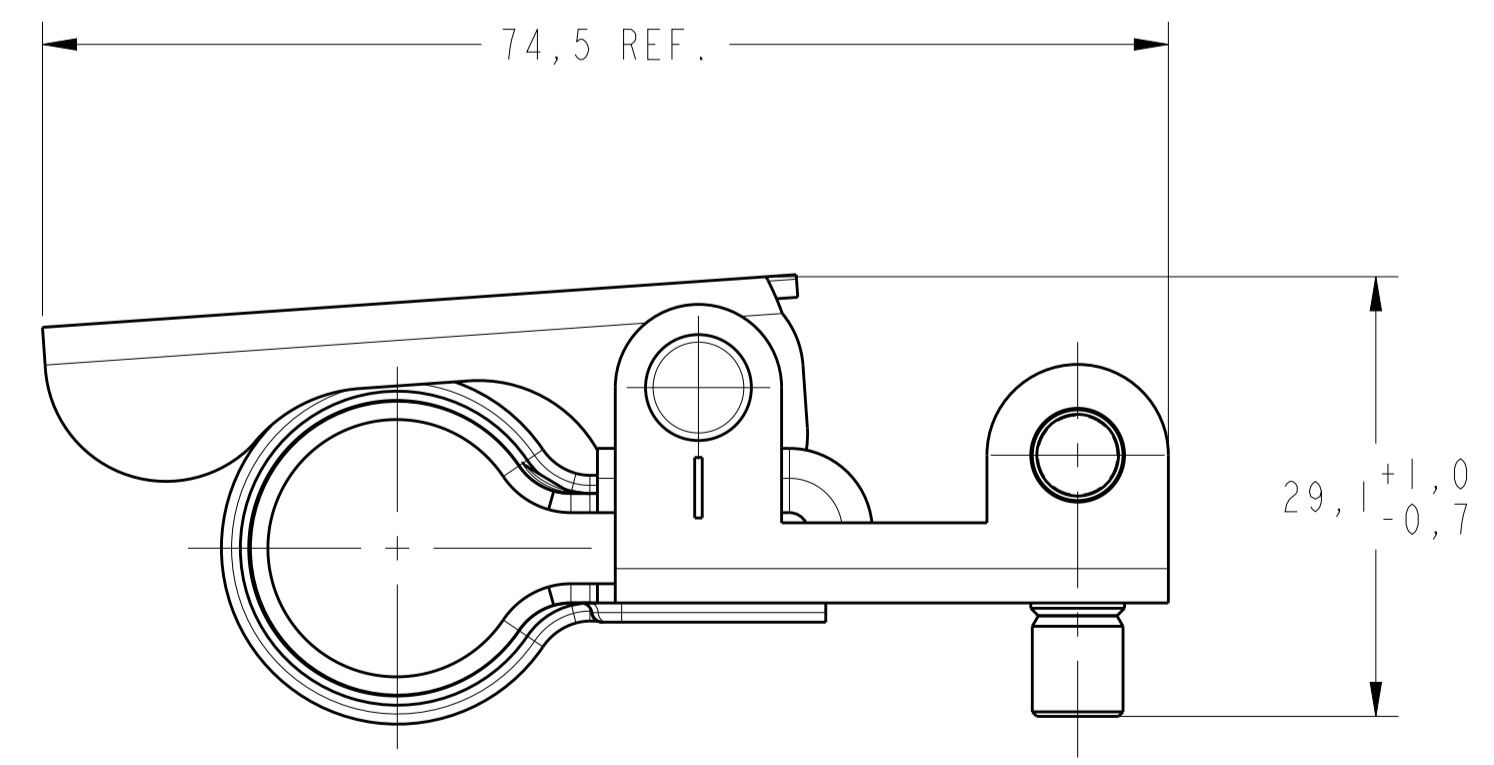
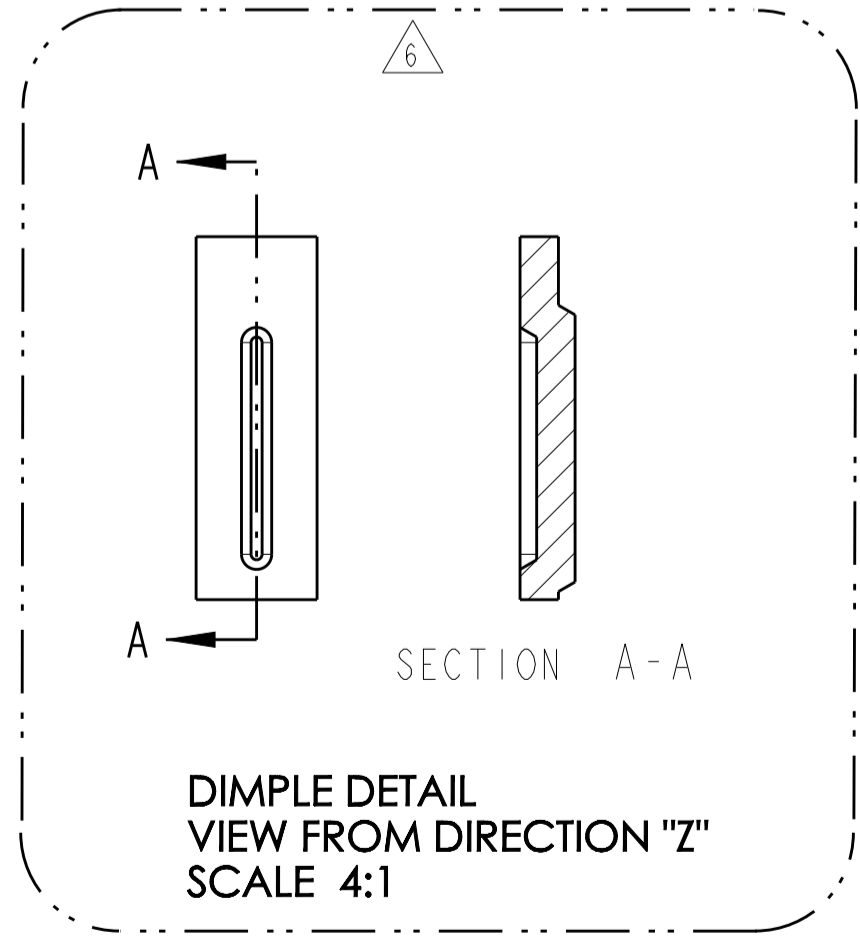
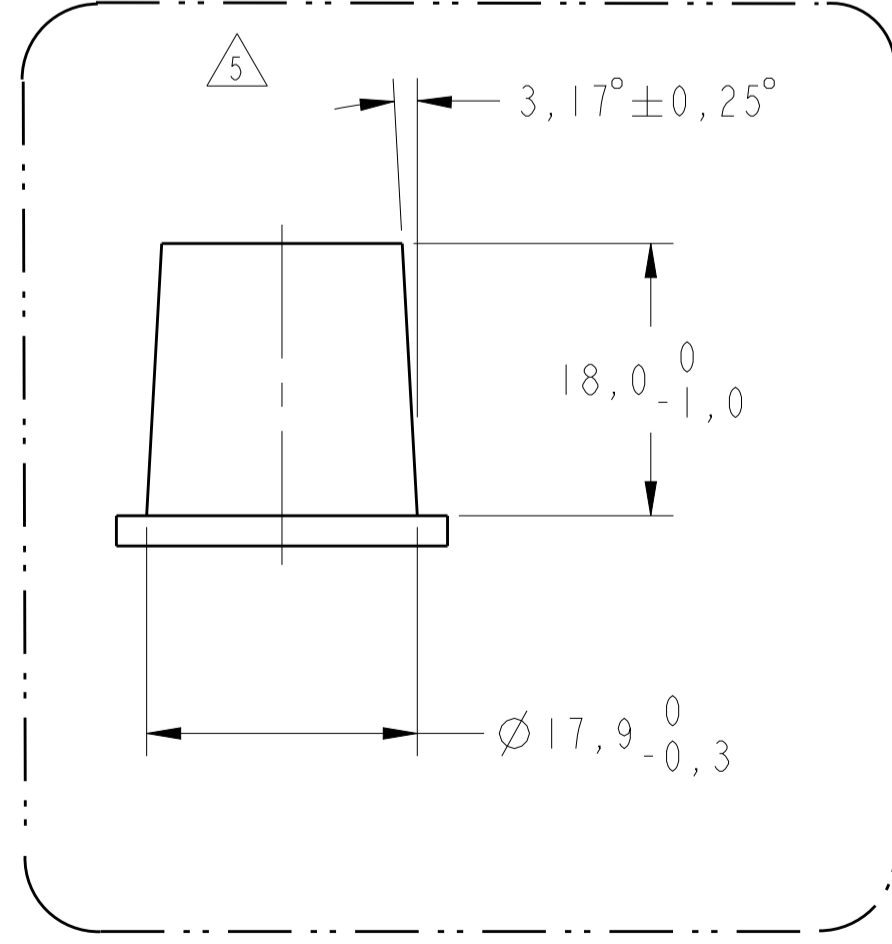

GRAVAÇÕES MARKINGS	
LOGOTIPO TE	
TE LOGO	
SINAL NEGATIVO (-)	
NEGATIVE SIGN (-)	

QTY	ITEM	DESCRIPTION	MATERIAL	FINISH						
1	1	SPECIAL BATTERY TERMINAL, METALLIC LEVER	LOW CARBON STEEL	ZINC PLATED						
-	-	9	IRON COOPER CuFe2P	TIN PLATED						
2	2	2	CARBON STEEL	ZINC PLATED						
1	1	1	LOW CARBON STEEL	ZINC PLATED						
-	-	1	LOW CARBON STEEL	ZINC PLATED						
-	-	2	CARBON STEEL	ZINC PLATED						
-	-	2	CARBON STEEL	ZINC PLATED						
-	-	1	LOW CARBON STEEL	ZINC PLATED						
-	-	1	LOW CARBON STEEL	ZINC PLATED						
1	1	1	BRASS CuZn30	TIN PLATED						
REQ. PER ASSY										
-8	-6	-5	-4	-3	-2	-1	ITEM	DESCRIPTION	MATERIAL	FINISH
1599923										

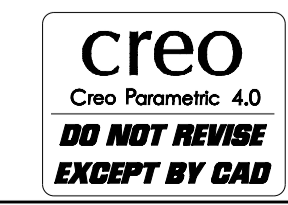

THIS DRAWING IS A CONTROLLED DOCUMENT.

DMN: ABALMEIDA 26OCT2005
 CHG: PLEFARIA 26OCT2005
 APVD: MGSOLDI 26OCT2005

TE Connectivity

SPECIAL BATTERY TERMINAL ASSEMBLY
 NEGATIVE
 (QUICK CONNECTION)

SIZE: A1 CAGE CODE: 00779 DRAWING NO: 1599923
 WEIGHT: 45,8 g
 Customer Drawing