

10 9 8 7 6 5 4 3 2 1

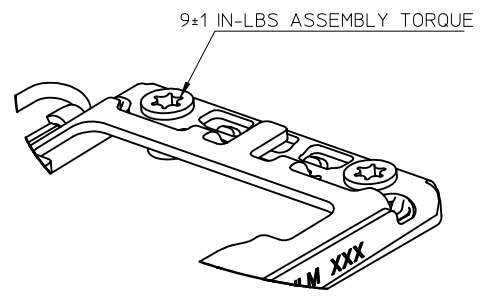
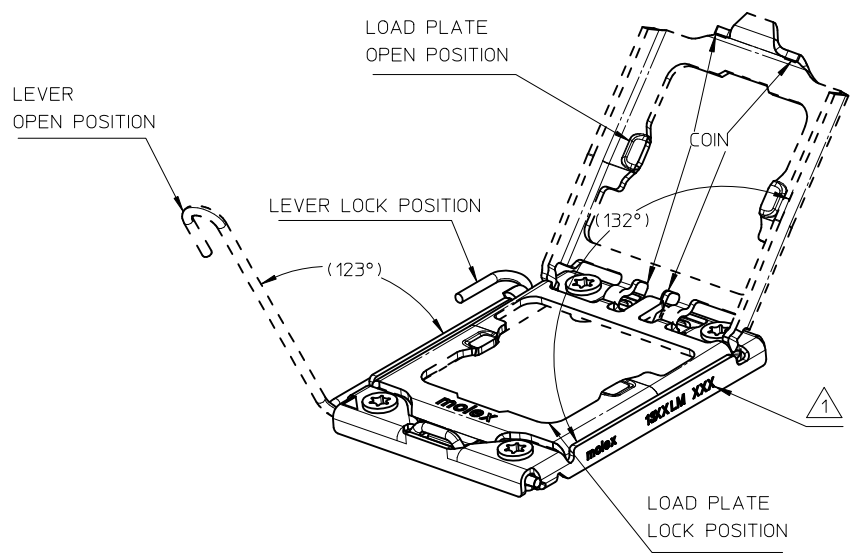

SCALE 2:1
DETAIL 1

- NOTES:
- 1. DATE CODE
 - 2. INK MARKING, FILL AREA WITH BLACK.
 - 3. THE PARTS 47593-9*** COMPLIANT TO RoHS DIRECTIVE 2002/95/EC AND ELV 2000/53/EC.

ENTER DESCRIPTION EC NO: SH2012-0262 DRWN: ZHANG11 2012/02/13 CHKD: APPR: AYIN 2012/02/23	DESCRIPTION REV	QUALITY SYMBOLS	GENERAL TOLERANCES (UNLESS SPECIFIED)		DIMENSION STYLE MM ONLY		SCALE 1:1	DESIGN UNITS METRIC	THIRD ANGLE PROJECTION		
		$F_A=0$ $F_G=0$ $F_P=0$	mm INCH 4 PLACES ± --- ± --- 3 PLACES ± --- ± --- 2 PLACES ± 0.2 ± --- 1 PLACE ± 0.3 ± ---	DRAWN BY YQSUN	DATE 2008/10/14	TITLE 13XX ILM ASSEMBLY					
		ANGULAR ± 1/2°	DRAFT WHERE APPLICABLE MUST REMAIN WITHIN DIMENSIONS	CHECKED BY FORD LIU	DATE 2008/10/14	MOLEX INCORPORATED DOCUMENT NO. SD-47593-900					
				APPROVED BY AYIN	DATE 2010/10/22	SHEET NO. 1 OF 3					
			SIZE A3	THIS DRAWING CONTAINS INFORMATION THAT IS PROPRIETARY TO MOLEX INCORPORATED AND SHOULD NOT BE USED WITHOUT WRITTEN PERMISSION							

9 8 7 6 5 4 3 2 1

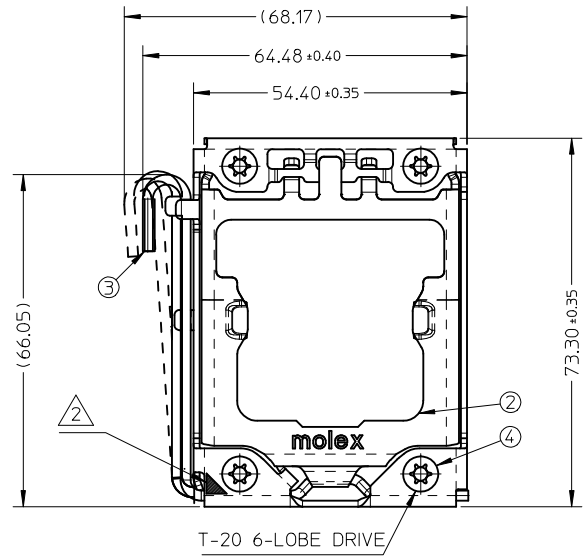

THIS VIEW IS ONLY FOR 475939000

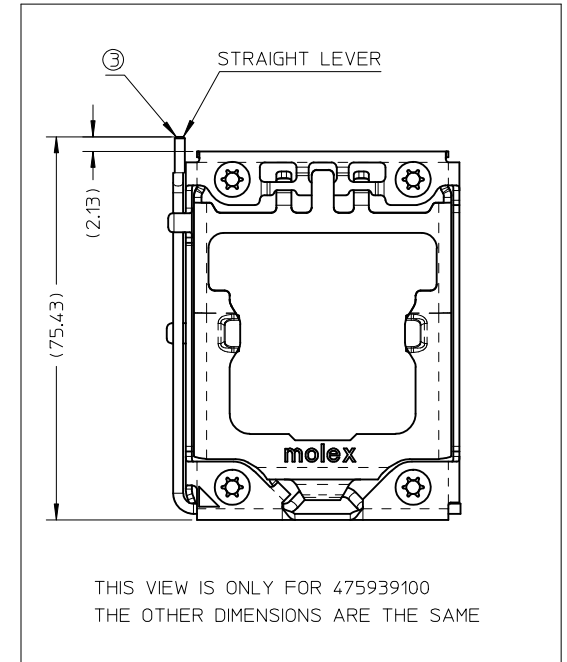
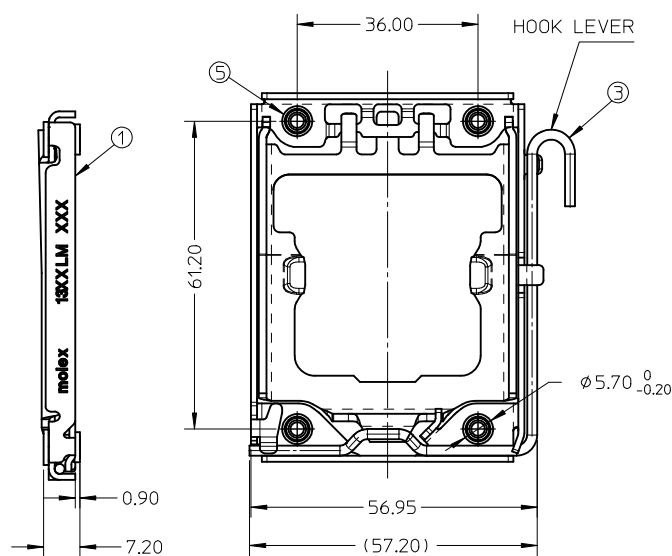

THIS VIEW IS ONLY FOR 475939100
THE OTHER DIMENSIONS ARE THE SAME

475939005	(5)	4	SOCKET 13XX FASTENER COLLAR	STEEL WITH NICKEL PLATING	
475939004	(4)	4	SOCKET 13XX FASTENER NUT	STEEL WITH NICKEL PLATING	
475939003	475939103	(3)	HOOK LEVER	STRAIGHT LEVER	STAINLESS STEEL
475939002	(2)	1	SOCKET 13XX ILM LOAD PLATE	STAINLESS STEEL	
475939001	(1)	1	SOCKET 13XX ILM FRAME	STEEL WITH NICKEL PLATING	
475939000	475939100		1	SOCKET 13XX ILM ASSEMBLY	
PART NO.	ITEM NO	QTY	DESCRIPTION	MATERIAL	

475939100	STRAIGHT LEVER	WITHOUT ILM COVER
475939000	HOOK LEVER	
PART NO.	DESCRIPTION	

ENTER DESCRIPTION EC NO: SH2012-0262 DRWN: ZHANG11 2012/02/13 CHKD: APPR: AYIN 2012/02/23	QUALITY SYMBOLS $F_A=0$ $F_C=0$ $F_P=0$	GENERAL TOLERANCES (UNLESS SPECIFIED)		DIMENSION STYLE MM ONLY		SCALE 1:1	DESIGN UNITS METRIC	THIRD ANGLE PROJECTION	
				mm INCH	DRAWN BY YQSUN	DATE 2008/10/14	TITLE 13XX ILM ASSEMBLY		
				4 PLACES ± --- ± --- 3 PLACES ± --- ± --- 2 PLACES ± 0.2 ± --- 1 PLACE ± 0.3 ± ---	CHECKED BY FORD LIU	DATE 2008/10/14	MOLEX INCORPORATED		
				ANGULAR ±1/2°	APPROVED BY AYIN	DATE 2010/10/22	MATERIAL NO. SEE TABLE	DOCUMENT NO. SD-47593-900	SHEET NO. 2 OF 3
		DRAFT WHERE APPLICABLE MUST REMAIN WITHIN DIMENSIONS		THIS DRAWING CONTAINS INFORMATION THAT IS PROPRIETARY TO MOLEX INCORPORATED AND SHOULD NOT BE USED WITHOUT WRITTEN PERMISSION					

10 9 8 7 6 5 4 3 2 1

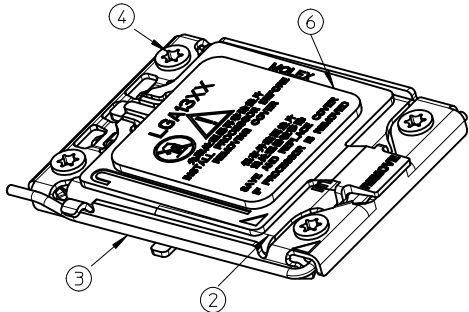

THIS VIEW IS ONLY FOR 475939170
THE OTHER DIMENSIONS ARE THE SAME.

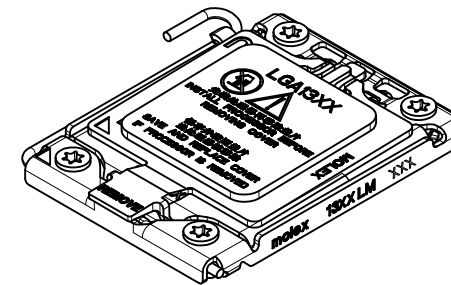
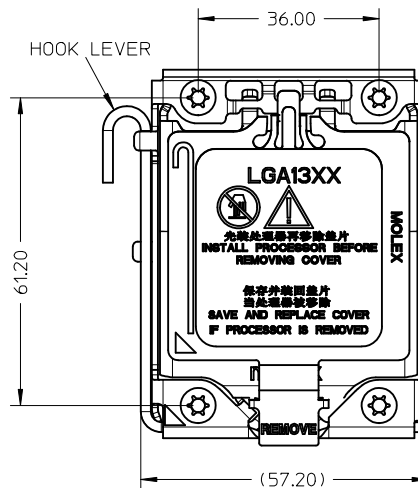
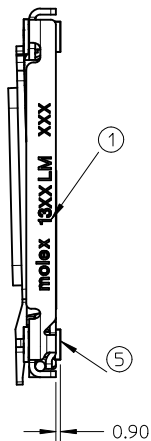

THIS VIEW IS ONLY FOR 475939070

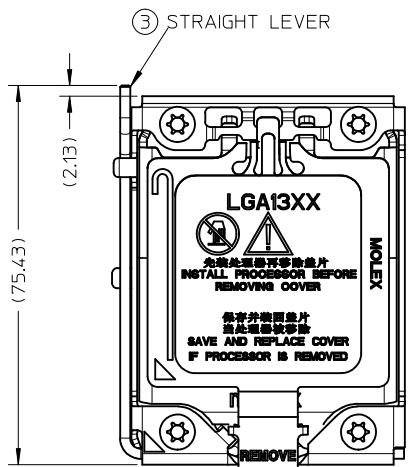
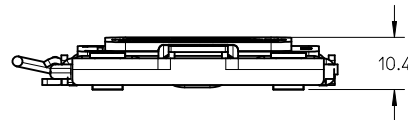

475930403	⑥	1	SOCKET 13XX ILM COVER	PC/ABS
475939005	⑤	4	SOCKET 13XX FASTENER COLLAR	STEEL WITH NICKEL PLATING
475939004	④	4	SOCKET 13XX FASTENER NUT	STEEL WITH NICKEL PLATING
475939003	③	1	HOOK LEVER	STAINLESS STEEL
475939103	③	1	STRAIGHT LEVER	STAINLESS STEEL
475939002	②	1	SOCKET 13XX ILM LOAD PLATE	STAINLESS STEEL
475939001	①	1	SOCKET 13XX ILM FRAME	STEEL WITH NICKEL PLATING
475939070	①	1	SOCKET 13XX ILM ASSEMBLY	
PART NO.	ITEM NO	QTY	DESCRIPTION	MATERIAL

475939170	STRAIGHT LEVER	WITH ILM COVER
475939070	HOOK LEVER	
PART NO.	DESCRIPTION	

ENTER DESCRIPTION
EC NO: SH2012-0262
DRAWN: ZHANG11 2012/02/13
CHKD:
APPR: AYIN 2012/02/23

QUALITY SYMBOLS
FA=0
FB=0
FC=0

GENERAL TOLERANCES (UNLESS SPECIFIED)

	mm	INCH
4 PLACES	± ---	± ---
3 PLACES	± ---	± ---
2 PLACES	± 0.2	± ---
1 PLACE	± 0.3	± ---

ANGULAR ±1/2°

DRAFT WHERE APPLICABLE
MUST REMAIN WITHIN DIMENSIONS

DIMENSION STYLE
MM ONLY

DRAWN BY	DATE
YOSUN	2008/10/14
CHECKED BY	DATE
FORD LIU	2008/10/14
APPROVED BY	DATE
AYIN	2010/10/22

MATERIAL NO.
SEE TABLE

SCALE 1:1
DESIGN UNITS METRIC
THIRD ANGLE PROJECTION

TITLE
13XX ILM ASSEMBLY

MOLEX MOLEX INCORPORATED
DOCUMENT NO. SD-47593-900
SHEET NO. 3 OF 3

THIS DRAWING CONTAINS INFORMATION THAT IS PROPRIETARY TO MOLEX INCORPORATED AND SHOULD NOT BE USED WITHOUT WRITTEN PERMISSION

9 8 7 6 5 4 3 2 1