

**Harvatek Surface Mount CHIP LEDs Data Sheet
B3173BGR-20C0001Q3U1930**



Official Product	HT Part No. B3173BGR-20C0001Q3U1930	Customer Part No.	Data Sheet No.
Tentative Product	*****	*****	
Specifications are subject to changes for improvement without advance notice. Proprietary data, drawings, company confidential all rights reserved.		06/08/2020	Version 1.6
			Page 1/15

DISCLAIMER	3
LIFE SUPPORT POLICY	3
PRODUCT SPECIFICATIONS	4
ATTENTION: ELECTROSTATIC DISCHARGE (ESD) PROTECTION	5
LABEL SPECIFICATIONS	6
SPECIFICATIONS RANGE	7
PRODUCT FEATURES	8
ELECTRO-OPTICAL CHARACTERISTICS	8
PACKAGE OUTLINE DIMENSION AND RECOMMENDED SOLDERING PATTERN FOR REFLOW	
SOLDERING	8
CHARACTERISTICS OF B3173BGR -20C	9
PRECAUTION FOR USE	11
PACKAGING	12
TAPE DIMENSION	12
REEL DIMENSION	13
PACKING	13
DRY PACK	14
BAKING	14
PRECAUTIONS	14
REFLOW SOLDERING	15
REWORKING	15
CLEANING	15
CAUTIONS OF PICK AND PLACE	16
REVISE HISTORY	16

Official Product	HT Part No. B3173BGR-20C0001Q3U1930	Customer Part No.	Data Sheet No.
Tentative Product	*****	*****	
Specifications are subject to changes for improvement without advance notice. Proprietary data, drawings, company confidential all rights reserved.		06/08/2020	Version 1.6
			Page 2/15

DISCLAIMER

HARVATEK reserves the right to make changes without further notice to any products herein to improve reliability, function or design. HARVATEK does not assume any liability arising out of the application or use of any product or circuit described herein; neither does it convey any license under its patent rights, nor the rights of others.

Life Support Policy

HARVATEK's products are not authorized for use as critical components in life support devices or systems without the express written approval of the President of HARVATEK or HARVATEK INTERNATIONAL. As used herein:

1. Life support devices or systems are devices or systems which, (a) are intended for surgical implant into the body, or (b) support or sustain life, and (c) whose failure to perform when properly used in accordance with instructions for use provided in the labeling, can be reasonably expected to result in a significant injury of the user.
2. A critical component in any component of a life support device or system whose failure to perform can be reasonably expected to cause the failure of the life support device or system, or to affect its safety or effectiveness.

Official Product	HT Part No. B3173BGR-20C0001Q3U1930	Customer Part No.	Data Sheet No.
Tentative Product	*****	*****	
Specifications are subject to changes for improvement without advance notice. Proprietary data, drawings, company confidential all rights reserved.		06/08/2020	Version 1.6 Page 3/15

Product Specifications

Item	Specification	Material	Quantity
Luminous Intensity(Iv)	R : 370-790 mcd G : 800-1150 mcd B : 130-340 mcd @20mA/ T _S = 25°C;Tolerance: ± 10%		
Wavelength	R : 620.0-630.0 nm G : 517.0-527.0 nm B : 462.0-472.0 nm @20mA/ T _S = 25°C;Tolerance: ± 0.5nm		
Vf	R : 1.8-2.4 V G : 2.6-3.4 V B : 2.6-3.4 V @20mA/ T _S = 25°C ;Tolerance: ± 0.05V		
Ir	< 1 μA @ V _R = 5V		
Resin	Clear	Epoxy	
Carrier tape	EIA 481-1A specs	Conductive black tape	3000ea/reel
Reel	EIA 481-1A specs	Conductive black	
Label	HT standard	Paper	
Packing bag	220x240mm	Aluminum laminated bag/ no-zipper	One reel per bag
Carton	HT standard	Paper	Non-specified

Official Product	HT Part No. B3173BGR-20C0001Q3U1930	Customer Part No.	Data Sheet No.
Tentative Product	*****	*****	
Specifications are subject to changes for improvement without advance notice. Proprietary data, drawings, company confidential all rights reserved.		06/08/2020	Version 1.6
			Page 4/15

Others:

Each immediate box consists of 5 reels. The 5 reels may not necessarily have the same lot number or the same bin combinations of I_V , λ_D and V_f . Each reel has a label identifying its specification; the immediate box consists of a product label as well.

Note :This is shipped test conditions

※Remarks: This product should be operated in forward bias. If a reverse voltage is continuously applied to the product, such operation can cause migration resulting in LED damage.

ATTENTION: Electrostatic Discharge (ESD) protection



The symbol to the left denotes that ESD precaution is needed. ESD protection for GaP and AlGaAs based chips is necessary even though they are relatively safe in the presence of low static-electric discharge. Parts built with AlInGaP, GaN, or/and InGaN based chips are **STATIC SENSITIVE devices**. ESD precaution must be taken during design and assembly.

If manual work or processing is needed, please ensure the device is adequately protected from ESD during the process.

Official Product	HT Part No. B3173BGR-20C0001Q3U1930	Customer Part No.	Data Sheet No.
Tentative Product	*****	*****	
Specifications are subject to changes for improvement without advance notice. Proprietary data, drawings, company confidential all rights reserved.		06/08/2020	Version 1.6
			Page 5/15

Label Specifications

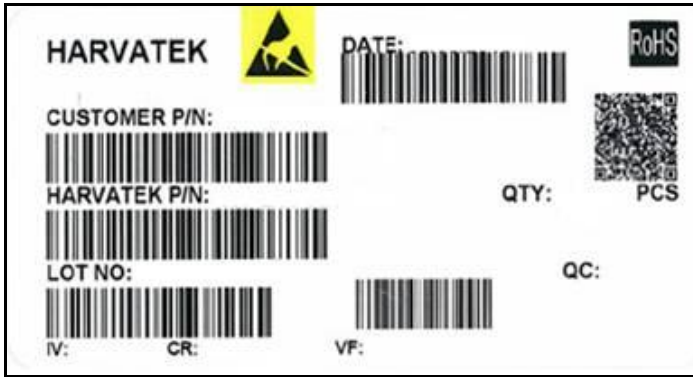

Harvatek P/N:

B 317 3 BGR- 20C 0001 Q3 U1930

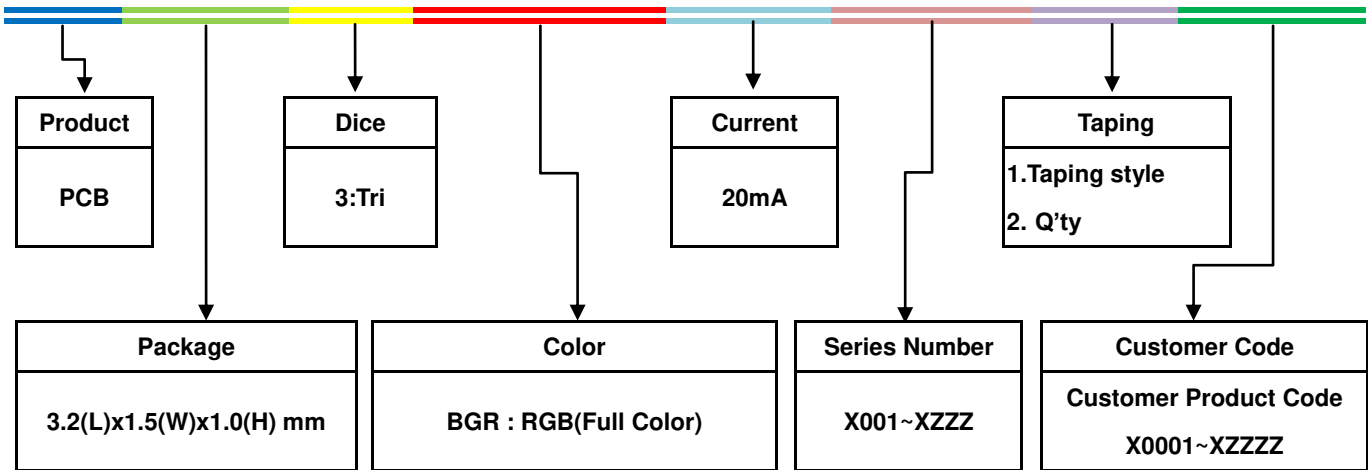

Lot No.:

1	2	3	4	5	6	7	8	9	10
E	1	A	1	A	2	2	L	1	2
Code 1 2		Code 3	Code 4	Code 5	Code 6	Code 7	Code 8	Code 9	Code 10
		Mfg. Year	Mfg. Month	Mfg. Date	Consecutive number		Special code		
Internal Tracing Code		2010-A		1:A	01~ZZ		000~ZZZ		
		2011-B		2:B					
		2012-C	1:Jan.	3:C					
		...	2:Feb.	...					
		2018-I/J	...	26:Z					
		2019-K	A:Oct.	27:7					
		...	B:Nov.	28:8					
2022-N	C:Dec.	29:9							
2023-P		30:3							
...		31:4							

Official Product	HT Part No. B3173BGR-20C0001Q3U1930	Customer Part No.	Data Sheet No.
Tentative Product	*****	*****	
Specifications are subject to changes for improvement without advance notice. Proprietary data, drawings, company confidential all rights reserved.		06/08/2020	Version 1.6 Page 6/15

Specifications Range

■ Luminous Intensity (Iv) Bin:

Luminous Intensity (Iv) Bin:R/G/B@20mA

HT-B3173BGR Series								
IV								
Red			Green			Blue		
KR1	370	540	KG1	800	1150	KB1	130	210
KR2	540	790				KB2	210	340

Note: It maintains a tolerance of $\pm 10\%$ on luminous intensity

Dominant Wavelength (λD) Bin:

HT-B3173 BGR Series								
WD								
Red			Green			Blue		
R1	620	625	G1	517	522	B1	462	467
R2	625	630	G2	522	527	B2	467	472

Note: It maintains a tolerance of $\pm 0.5\text{nm}$ on Wavelength bin

Forward Voltage (Vf) Bin:

HT-B3173BGR Series								
VF								
Red			Green			Blue		
F	1.8	2.4	G38	2.6	3.4	G38	2.6	3.4

Note: It maintains a tolerance of $\pm 0.05\text{V}$ on forward voltage measurement

Official Product	HT Part No. B3173BGR-20C0001Q3U1930	Customer Part No.	Data Sheet No.
Tentative Product	*****	*****	
Specifications are subject to changes for improvement without advance notice. Proprietary data, drawings, company confidential all rights reserved.		06/08/2020	Version 1.6 Page 7/15

Product Features

Electro-Optical Characteristics

(T_{Soldering} : 25 °C)

Series	Emitting Color	Material	V _F (V)		Wavelength λ(nm)			I _v (mcd)	Viewing Angle 2θ _{1/2}
			typ	max	λ _D	λ _P	Δ λ	Typical	
B3173BGR-20	Red	AllnGaP	2.0	2.4	622	632	20	450	X=118 Y=145
	Green	InGaN	2.6	3.4	523	520	30	850	X=125 Y=128
	Blue	InGaN	2.6	3.4	465	468	40	140	X=124 Y=136

Package Outline Dimension and Recommended Soldering Pattern for Reflow Soldering

(Unit:mm Tolerance: +/-0.1)

Outline Dim.	Soldering Pattern
Soldering terminals may shift in the x, y direction.	

Official Product	HT Part No. B3173BGR-20C0001Q3U1930	Customer Part No.	Data Sheet No.
Tentative Product	*****	*****	
Specifications are subject to changes for improvement without advance notice. Proprietary data, drawings, company confidential all rights reserved.		06/08/2020	Version 1.6
			Page 8/15

(T_{Soldering} 25 °C)

Absolute Maximum Ratings

Series	P _D (mW)	V _R (V)	I _F (mA)	I _{FP} (mA)*	Top(°C)
Color	Power Dissipation	Reverse Voltage	Forward Current	Pulse Forward Current	Operating Temperature
Red	45	5	20	≤ 60	-30~+80
Green	56	5	20	≤ 30	
Blue	60	5	20	≤ 30	

*Condition for I_{FP} is pulse of 1/10 duty and 0.1msec width

*Remarks: This product should be operated in forward bias. If a reverse voltage is continuously applied to the product, such operation can cause migration resulting in LED damage.

Characteristics of B3173BGR -20C

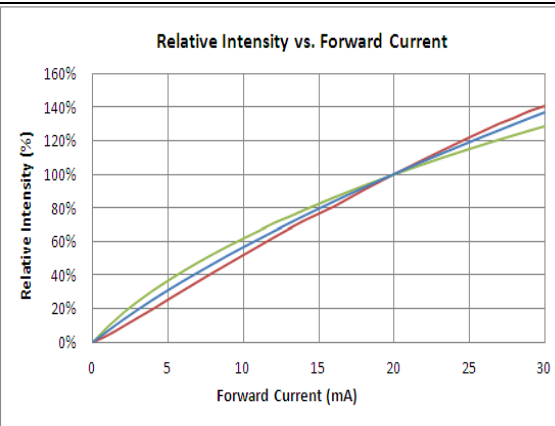
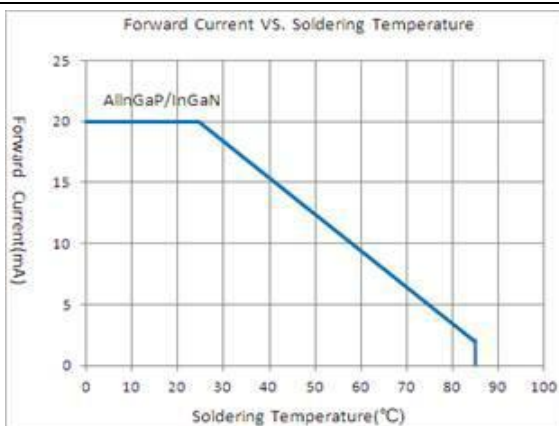
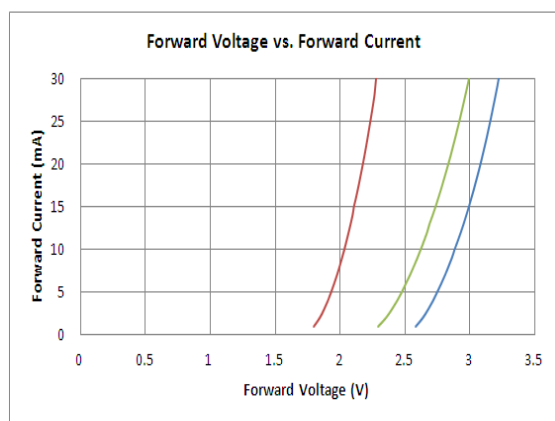
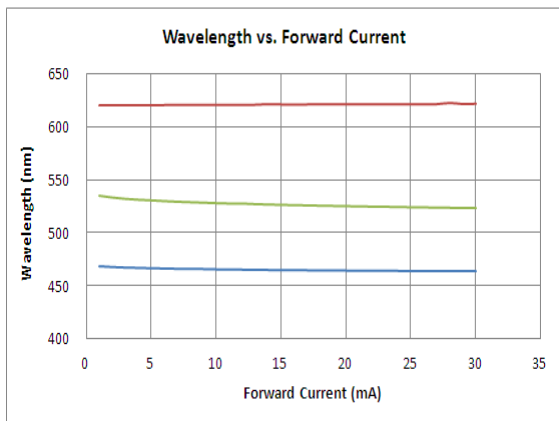

Official Product	HT Part No. B3173BGR-20C0001Q3U1930	Customer Part No.	Data Sheet No.
Tentative Product	*****	*****	
Specifications are subject to changes for improvement without advance notice. Proprietary data, drawings, company confidential all rights reserved.	06/08/2020	Version 1.6	Page 9/15

Directive Characteristics

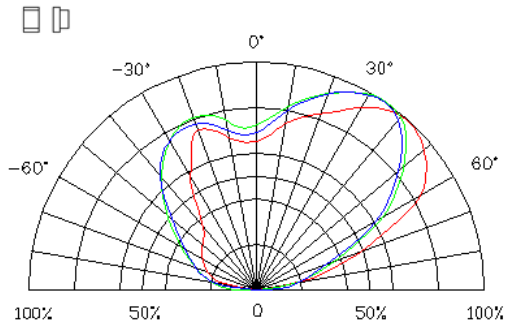

Directive Characteristics

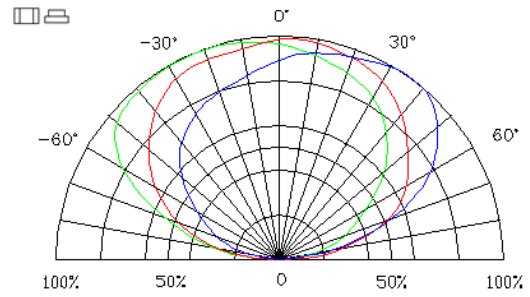

Official Product	HT Part No. B3173BGR-20C0001Q3U1930	Customer Part No.	Data Sheet No.
Tentative Product	*****	*****	
Specifications are subject to changes for improvement without advance notice. Proprietary data, drawings, company confidential all rights reserved.		06/08/2020	Version 1.6
			Page 10/15

Precaution for Use

1. The chips should not be used directly in any type of fluid such as water, oil, organic solvent, etc.
2. When the LEDs are illuminating, the maximum ambient temperature should be first considered before operation.
3. LEDs must be stored in a clean environment. A sealed container with a nitrogen atmosphere is necessary if the storage period is over 3 months after shipping.
4. The LEDs must be used within 72 hrs after unpacked. Unused products must be repacked in an anti-electrostatic package, folded to close any opening and then stored in a dry and cool space.
5. The appearance and specifications of the products may be modified for improvement without further notice.
6. The LEDs are sensitive to the static electricity and surge. It is strongly recommended to use a grounded wrist band and anti-electrostatic glove when handling the LEDs. If a voltage over the absolute maximum rating is applied to LEDs, it will damage LEDs. Damaged LEDs will show some abnormal characteristics such as remarkable increase of leak current, lower turn-on voltage and getting unlit at low current.

Official Product	HT Part No. B3173BGR-20C0001Q3U1930	Customer Part No.	Data Sheet No.
Tentative Product	*****	*****	
Specifications are subject to changes for improvement without advance notice. Proprietary data, drawings, company confidential all rights reserved.		06/08/2020	Version 1.6 Page 11/15

Packaging Tape Dimension

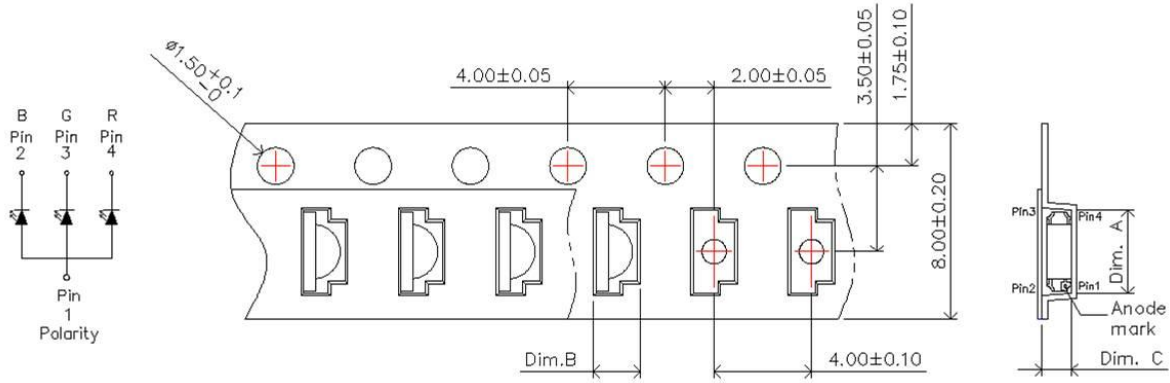

Dim. A	Dim. B	Dim. C	Q'ty/Reel
3.40 ± 0.10	1.70 ± 0.10	1.20 ± 0.10	3K

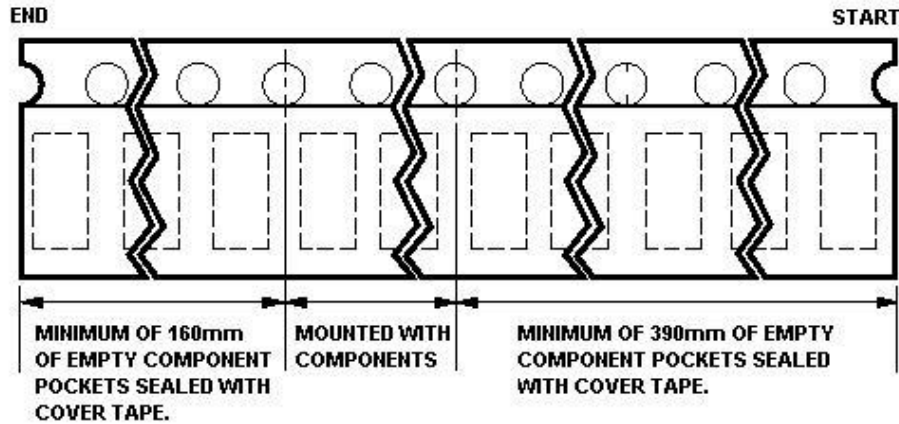

Official Product	HT Part No. B3173BGR-20C0001Q3U1930	Customer Part No.	Data Sheet No.
Tentative Product	*****	*****	
Specifications are subject to changes for improvement without advance notice. Proprietary data, drawings, company confidential all rights reserved.		06/08/2020	Version 1.6
			Page 12/15

Reel Dimension

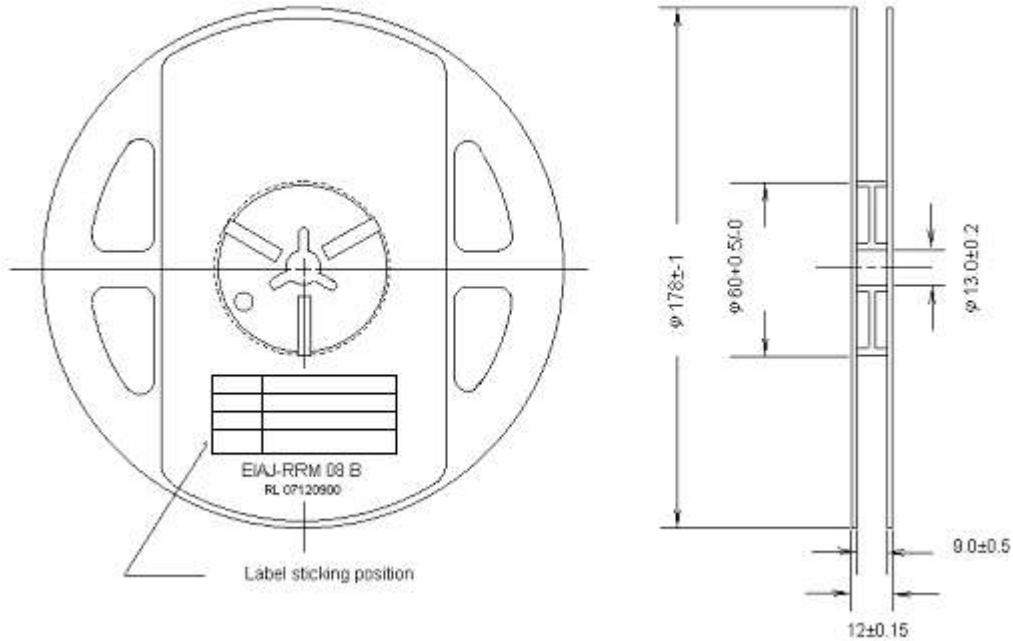

Packing

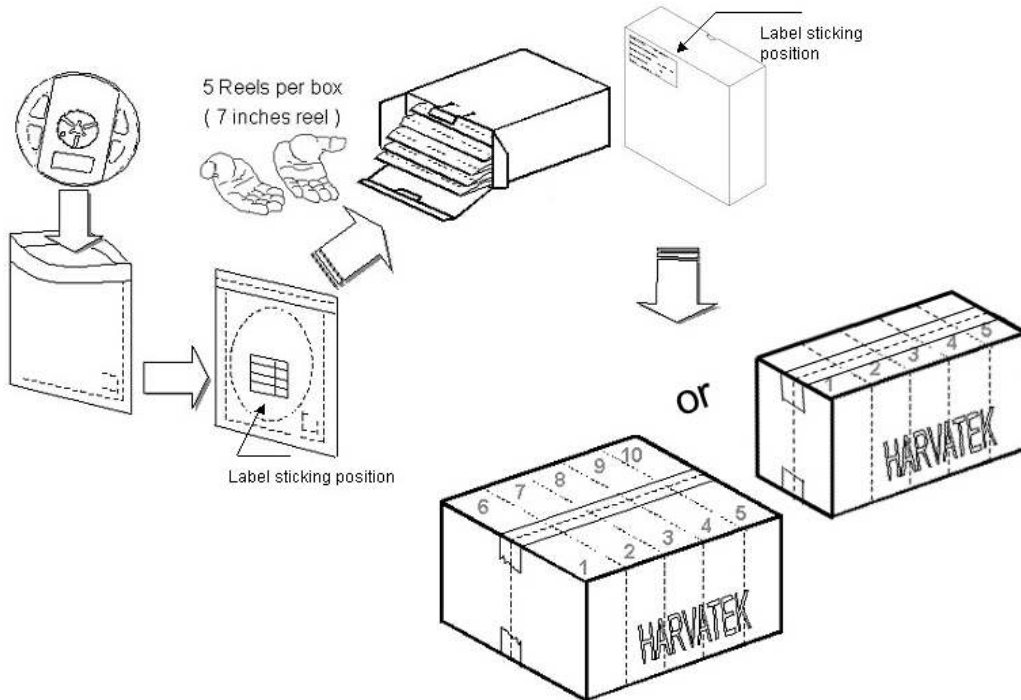

5 or 10 boxes per carton is available depending on shipment quantity.

Official Product	HT Part No.	Customer Part No.		Data Sheet No.
	B3173BGR-20C0001Q3U1930			
Tentative Product	*****	*****		
Specifications are subject to changes for improvement without advance notice. Proprietary data, drawings, company confidential all rights reserved.		06/08/2020	Version 1.6	Page 13/15

Dry Pack

All SMD optical devices are **MOISTURE SENSITIVE**. Avoid exposure to moisture at all times during transportation or storage. Every reel is packaged in a moisture protected anti-static bag. Each bag is properly sealed prior to shipment.

A humidity indicator will be included in the moisture protected anti-static bag prior to shipment.

The packaging sequence is as follows:

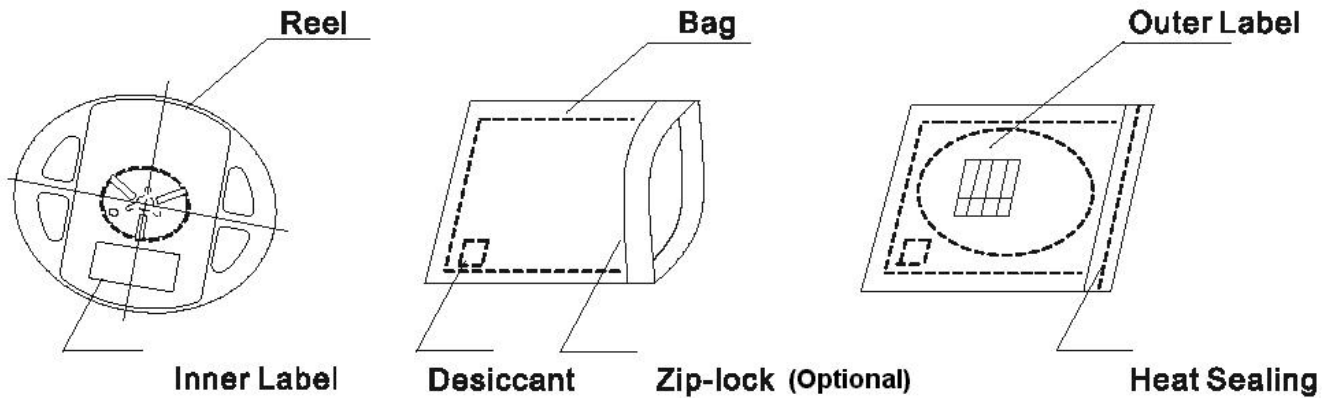

Baking

Baking before soldering is recommended when the package has been unsealed for 72 hrs.

The conditions are as followings:

1. $60\pm 3^{\circ}\text{C} \times (12\sim 24\text{hrs})$ and $<5\%RH$, taped reel type.
2. $100\pm 3^{\circ}\text{C} \times (45\text{min}\sim 1\text{hr})$, bulk type.
3. $130\pm 3^{\circ}\text{C} \times (15\text{min}\sim 30\text{min})$, bulk type.

Precautions

1. Avoid exposure to moisture at all times during transportation or storage.
2. Anti-Static precaution must be taken when handling GaN, InGaN, and AlInGaP products.
3. It is suggested to connect the unit with a current limiting resistor of the proper size. Avoid applying a reverse voltage beyond the specified limit.
4. Avoid operation beyond the limits as specified by the absolute maximum ratings.
5. Avoid direct contact with the surface through which the LED emits light.
6. If possible, assemble the unit in a clean room or dust-free environment.

Official Product	HT Part No. B3173BGR-20C0001Q3U1930	Customer Part No.	Data Sheet No.
Tentative Product	*****	*****	
Specifications are subject to changes for improvement without advance notice. Proprietary data, drawings, company confidential all rights reserved.		06/08/2020	Version 1.6 Page 14/15

Reflow Soldering

Recommend soldering paste specifications:

1. Operating temp.: Above 217°C ,60~150 sec.
2. Peak temp.:260 °C Max.,10sec Max.
3. Reflow soldering should not be done more than two times.
4. Never attempt next process until the component is cooled down to room temperature after reflow.
5. The recommended reflow soldering profile (measured on the surface of the LED terminal) is as following:

Lead-free Solder Profile

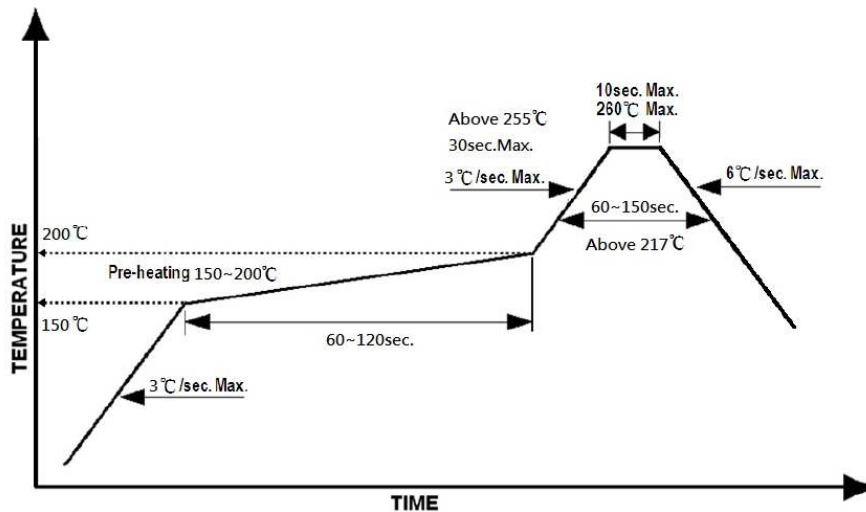

Reworking

- Rework should be completed within 5 seconds under 260 °C .
- The iron tip must not come in contact with the copper foil.
- Twin-head type is preferred.

Cleaning

Following are cleaning procedures after soldering:

- An alcohol-based solvent such as isopropyl alcohol (IPA) is recommended.
- Temperature x Time should be 50°C x 30sec. or <30°C x 3min
- Ultrasonic cleaning: < 15W/ bath; bath volume ≤ 1liter
- Curing: 100 °C max, <3min

Official Product	HT Part No. B3173BGR-20C0001Q3U1930	Customer Part No.	Data Sheet No.
Tentative Product	*****	*****	
Specifications are subject to changes for improvement without advance notice. Proprietary data, drawings, company confidential all rights reserved.		06/08/2020	Version 1.6 Page 15/15

Cautions of Pick and Place

- Avoid stress on the resin at elevated temperature.
- Avoid rubbing or scraping the resin by any object.
- Electric-static may cause damage to the component. Please ensure that the equipment is properly grounded. Use of an ionizer fan is recommended.

Revise History

Rev.	Descriptions	Date	Page
1.0	-	03/10/2016	-
1.1	Renew form	12/26/2017	-
1.2	Renew form	03/29/2018	-
1.3	Renew form	10/30/2018	-
1.4	Change Product MSL rating from Level 2a to Level 4.	05/06/2019	P10+P13
1.5	Renew form	03/17/2020	-
1.6	Renew form	09/11/2020	-
1.7	Add Customer Product Code	09/15/2020	P5

Official Product	HT Part No. B3173BGR-20C0001Q3U1930	Customer Part No.		Data Sheet No.
Tentative Product	*****	*****		
Specifications are subject to changes for improvement without advance notice. Proprietary data, drawings, company confidential all rights reserved.		06/08/2020	Version 1.6	Page 16/15