

LOC		DIST		REVISIONS			
P	LTR	DESCRIPTION	DATE	DWN	APVD		
F		REVISED	26 JAN 2011	T.S	N.Y		
F1		ADD P/N 6376610-3	18 OCT 2018	A.W	R.B		
F2		ADD MISSING PCB DIMENSION	25 JAN 2019	A.W	R.B		

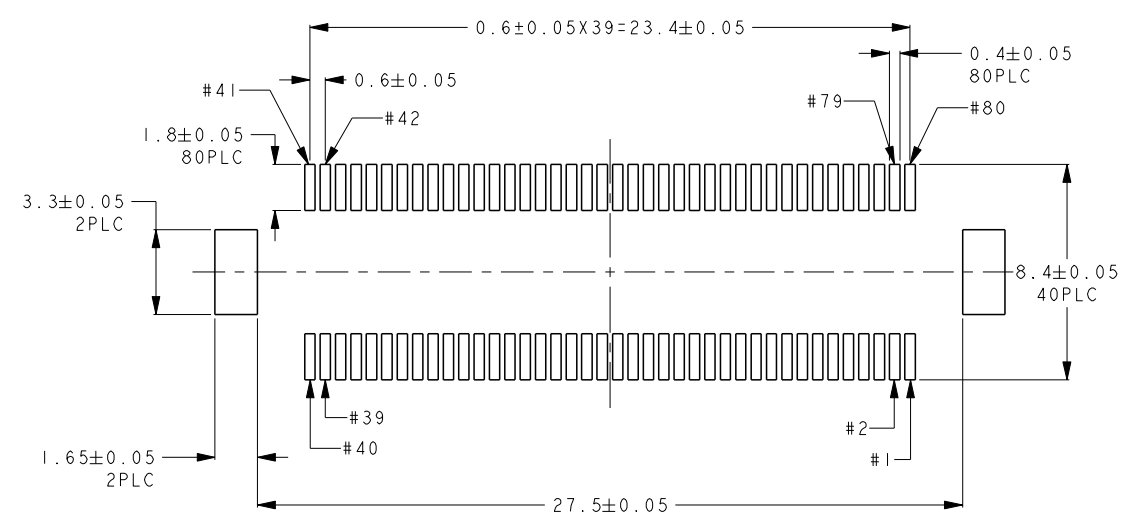
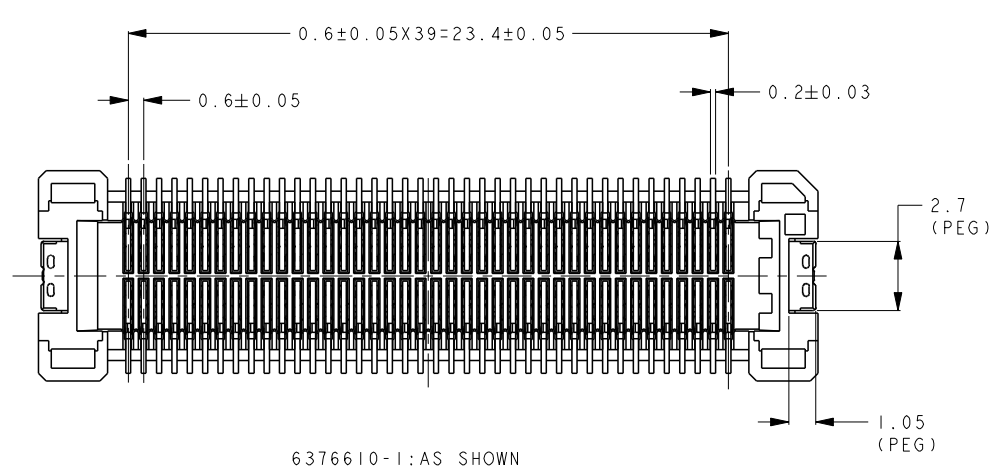
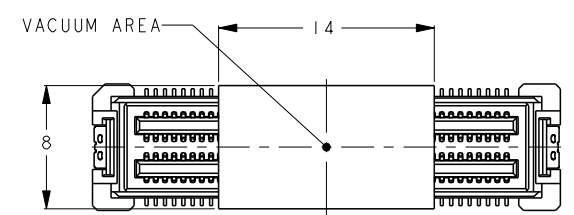
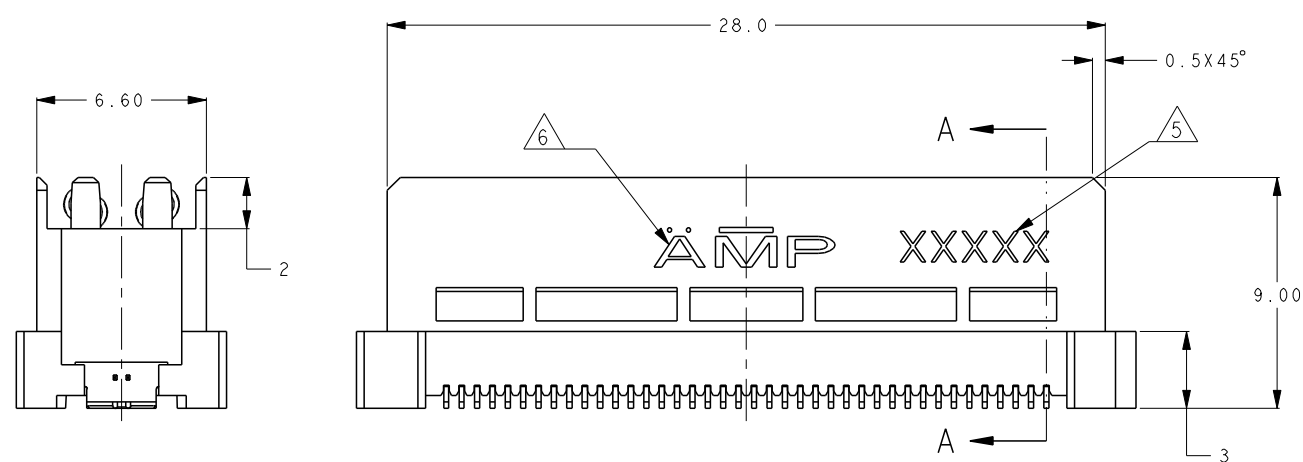
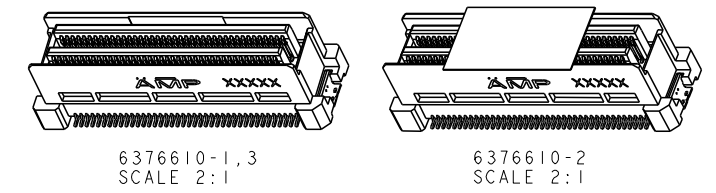
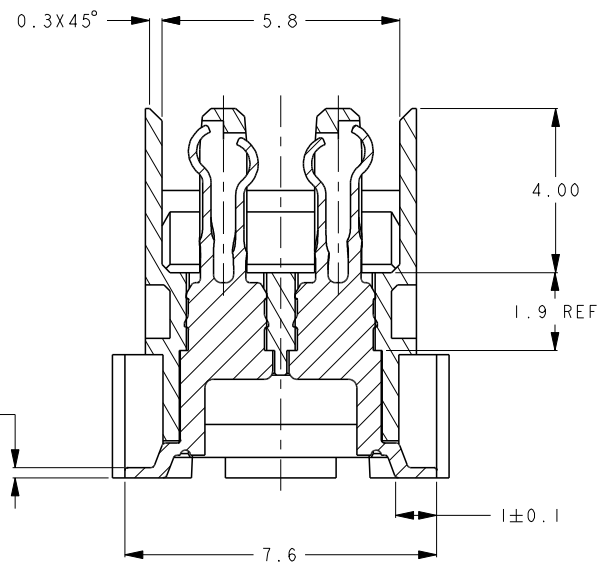
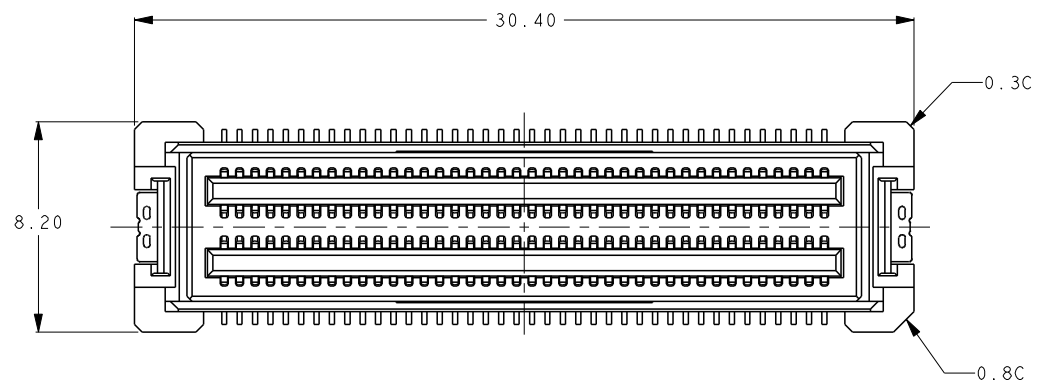

- ① MATERIAL : HOUSING; LCP  
; CONTACT; COPPER ALLOY
- ② FINISH : UNDER Ni PL. 0.8μmMIN  
CONTACT AREA: Au PL. 0.3μmMIN  
SOLDERING AREA: Au FLASH
- 3. COPLANARITY 0.1MAX.
- 4. SHOULD BE PUT 45 CONNECTORS IN HARD TRAY. (SEE SHEET 2)
- ⑤ DATE CODE IS MARKED TO CHINA PRODUCTION PRODUCT.  
THE FACE SIDE AND BACK SIDE IS NOT ASKED.
- ⑥ AMP : MADE IN JAPAN  
AMP : MADE IN CHINA
- ⑦ CONNECTORS AND TRAY SHALL BE COVERED BY PLASTIC BAG  
WITH ENCLOSED DESICCANT.

DESCRIPTION	PACKAGE	PART NO
WITH POLYIMIDE TAPE	HARD TRAY	6376610-2
W/O POLYIMIDE TAPE	HARD TRAY	⑦ 6376610-3
W/O POLYIMIDE TAPE	HARD TRAY	6376610-1

THIS DRAWING IS A CONTROLLED DOCUMENT FOR TYCO ELECTRONICS CORPORATION IT IS SUBJECT TO CHANGE AND THE CONTROLLING ENGINEERING ORGANIZATION SHOULD BE CONTACTED FOR THE LATEST REVISION.		DWN K. Sakai 23 JAN 2006	Tyco Electronics Corporation Kawasaki, Japan
DIMENSIONS: mm		CHK E. Takemasa 23 JAN 2006	
TOLERANCES UNLESS OTHERWISE SPECIFIED: 0 PLC ±0.3 1 PLC ±0.25 2 PLC ±0.2 3 PLC ± 4 PLC ± ANGLES ±3° FINISH		APVD M. Kimura 23 JAN 2006	NAME HDR ASSEMBLY 9mm HEIGHT 0.6mm PITCH 80P MICRO STACK CONNECTOR
MATERIAL ① SEE NOTE		PRODUCT SPEC 108-5724	SIZE A200779
② SEE NOTE		APPLICATION SPEC	DRAWING NO C-6376610
CUSTOMER DRAWING		WEIGHT 2.1g	RESTRICTED TO
		SCALE 5:1	SHEET 1 OF 2
			REV F2

4

3

2

1

THIS DRAWING IS UNPUBLISHED. RELEASED FOR PUBLICATION 20  
© COPYRIGHT 20 BY TYCO ELECTRONICS CORPORATION. ALL INTERNATIONAL RIGHTS RESERVED.

LOC	DIST	REVISIONS					
J	-	P	LTR	DESCRIPTION	DATE	DWN	APVD
		-		SEE SHEET 1			

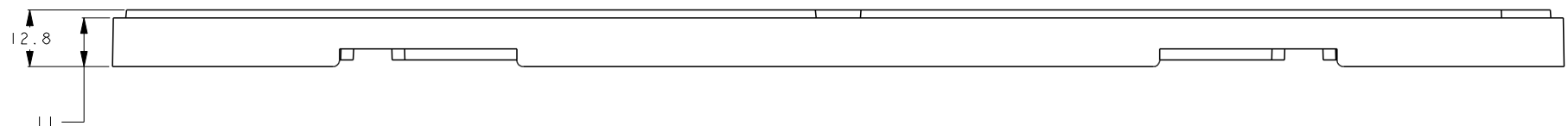
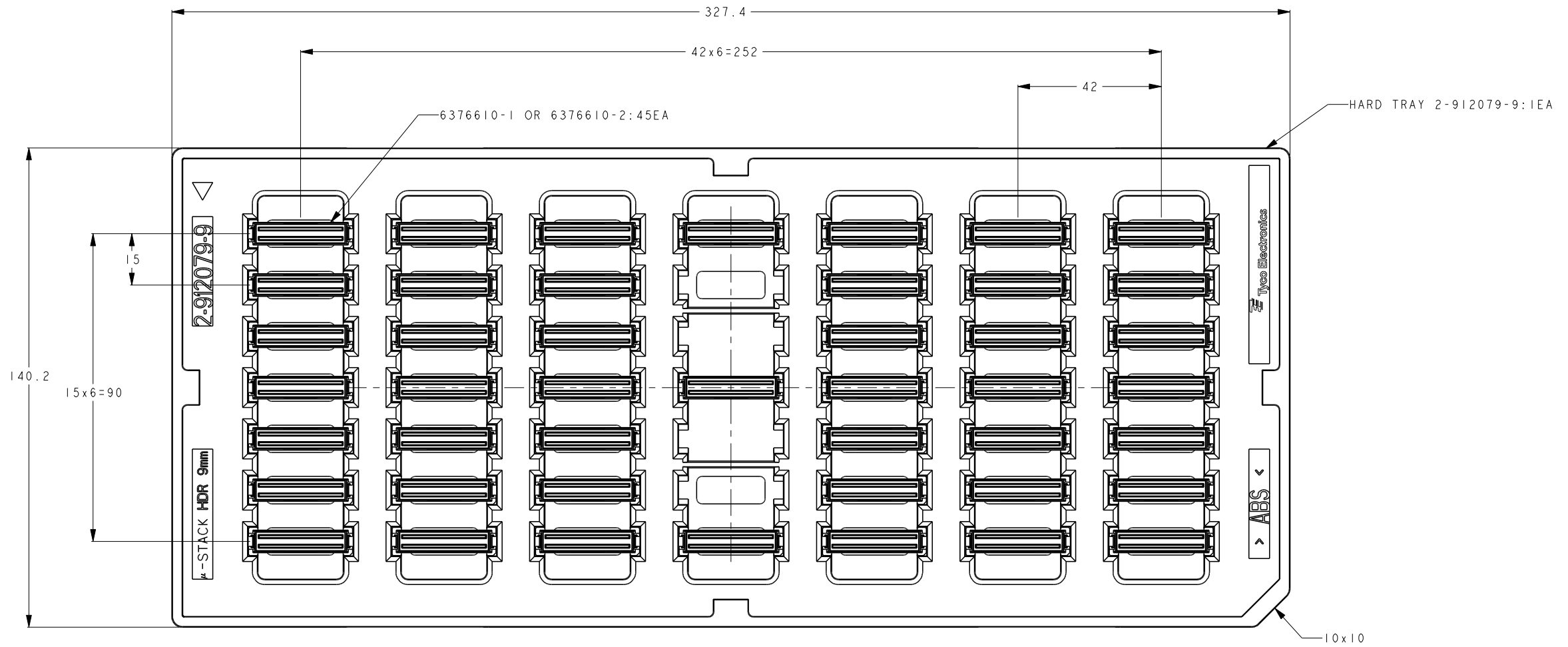

### HARD TRAY ASSEMBLY SPEC

<small>THIS DRAWING IS A CONTROLLED DOCUMENT FOR TYCO ELECTRONICS CORPORATION IT IS SUBJECT TO CHANGE AND THE CONTROLLING ENGINEERING ORGANIZATION SHOULD BE CONTACTED FOR THE LATEST REVISION.</small>		DWN K. Sakai 23JAN2006 CHK E. Takemasa 23JAN2006 APVD M. Kimura 23JAN2006	Tyco Electronics Corporation Kawasaki, Japan
DIMENSIONS: mm	TOLERANCES UNLESS OTHERWISE SPECIFIED: 0-PLC ±1 1-PLC ±0.3 2-PLC ±0.25 3-PLC ±0.2 4-PLC ± ANGLES ±3° FINISH	NAME HDR ASSEMBLY 9mm HEIGHT 0.6mm PITCH 80P MICRO STACK CONNECTOR PRODUCT SPEC 108-5724 APPLICATION SPEC - WEIGHT 2.1g	SIZE CAGE CODE DRAWING NO A200779C-6376610 RESTRICTED TO
MATERIAL		CUSTOMER DRAWING	SCALE 5:1 SHEET 2 OF 2 REV F2