



# EVQ6532-V-00A

## 5V to 60V, Three-Phase Brushless DC Motor Pre-Driver Evaluation Board, AEC-Q100 Qualified

### DESCRIPTION

The EVQ6532-V-00A is an evaluation board designed to demonstrate the capabilities of the MPQ6532, a three-phase brushless DC (BLDC) motor pre-driver.

The MPQ6532 operates with a supply voltage of up to 60V. It is configured to drive three half-bridges, which consist of six N-channel power

MOSFETs. The Hall sensors integrated in the motor provide the rotor position information, and the external controller (e.g. MCU or FPGA) generates the driving control signals.

It is recommended to read the MPQ6532 datasheet prior to making any changes to the EVQ6532-V-00A.

### PERFORMANCE SUMMARY

Parameters	Value
Input voltage ( $V_{IN}$ ) range	5V to 60V
OC_REF voltage ( $V_{OC\_REF}$ )	0.125V to 2.4V
VH voltage ( $V_H$ )	3.3V or 5V
Typical dead time	1.4 $\mu$ s

### EVALUATION BOARD

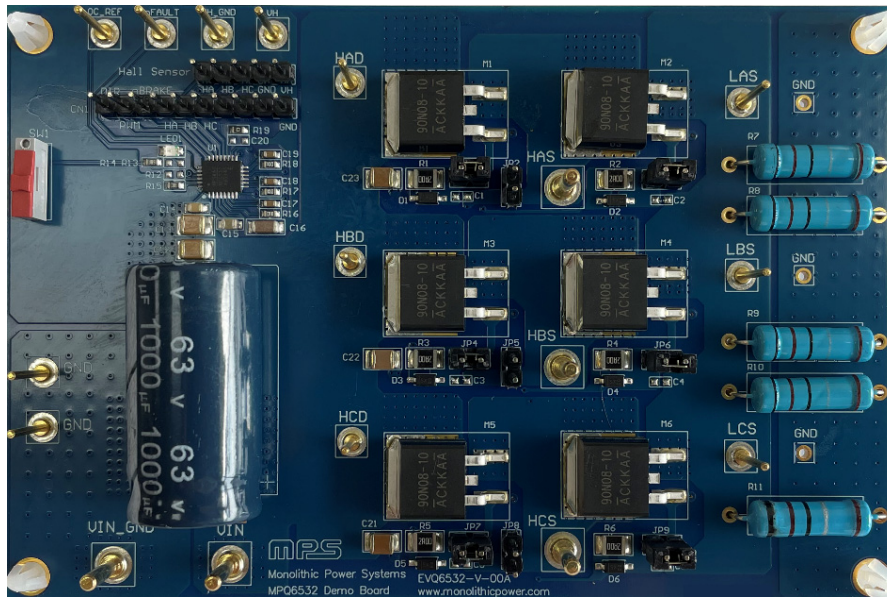

**LxW (11.7cmx7.8cm)**

Board Number	MPS IC Number
EVQ6532-V-00A	MPQ6532GVE-AEC1

## QUICK START GUIDE

1. Connect the input voltage ( $5V \leq V_{IN} \leq 60V$ ) to the VIN connector, then connect input ground to the GND connector.
2. Connect the VH voltage (3.3V or 5V) to the VH connector, then switch SW1 down to the position 1 terminal (see Figure 1) to enable the MPQ6532.
3. To set the over-current protection (OCP) threshold, connect the OC\_REF voltage ( $0.125V \leq V_{OC\_REF} \leq 2.4V$ ) to the OC\_REF connector.
4. Connect the Hall signals coming from the motor to the Hall Sensor connector.
5. Connect the driving control signals generated by the external controller to the CN1 connector.

# EVALUATION BOARD SCHEMATIC

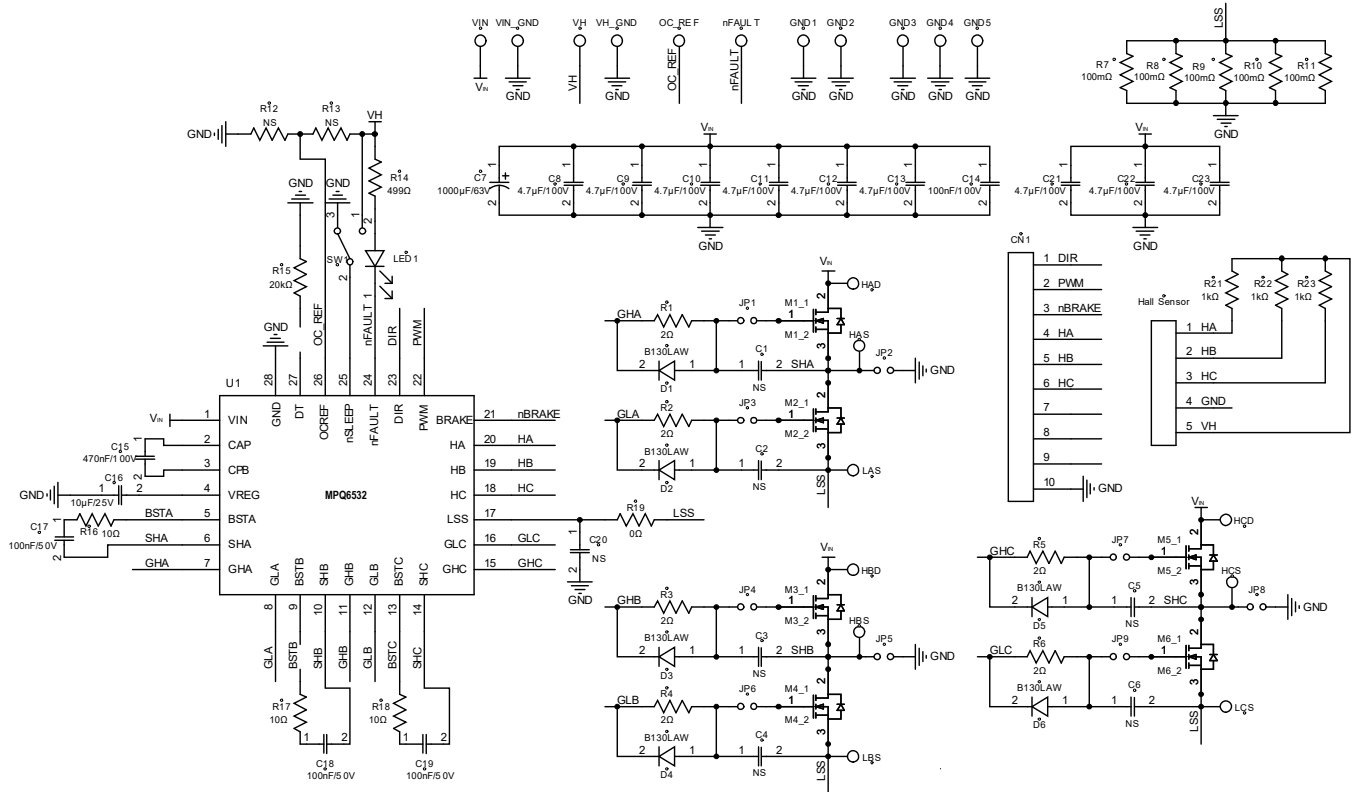

Figure 1: Evaluation Board Schematic

**EVQ6532-V-00A BILL OF MATERIALS**

Qty	Ref	Value	Description	Package	Manufacturer	Manufacturer PN
9	C1, C2, C3, C4, C5, C6, C20, R12, R13	NS				
1	C7	1000 $\mu$ F	Electrolytic capacitor, 63V	DIP	Jianghai	CD263-63V1000
9	C8, C9, C10, C11, C12, C13, C21, C22, C23	4.7 $\mu$ F	Ceramic capacitor, 100V, X7S	1210	TDK	C3225X7S2A475K
1	C14	100nF	Ceramic capacitor, 100V, X7R	0805	Murata	GRM21BR72A104KAC4L
1	C15	470nF	Ceramic capacitor, 100V, X7R	0805	Murata	GRM21BR72A474KA73L
1	C16	10 $\mu$ F	Ceramic capacitor, 25V, X5R	1206	TDK	C3216X5R1E106K
3	C17, C18, C19	100nF	Ceramic capacitor, 50V, X7R	0603	Murata	GCJ188R71H104KA12D
6	R1, R2, R3, R4, R5, R6	2 $\Omega$	Film resistor, 1%	1210	Yageo	RC1210FR-072RL
5	R7, R8, R9, R10, R11	100m $\Omega$	Resistor, 2W	DIP	Any	
1	R14	499 $\Omega$	Film resistor, 1%	0603	Yageo	RC0603FR-07499RL
1	R15	20k $\Omega$	Film resistor, 1%	0603	Yageo	RC0603FR-0720KL
3	R16, R17, R18	10 $\Omega$	Film resistor, 1%	0603	Yageo	RC0603FR-0710RL
1	R19	0 $\Omega$	Film resistor, 1%	0603	Yageo	RC0603FR-070RL
3	R21, R22, R23	1k $\Omega$	Film resistor, 1%	0603	Yageo	RC0603FR-071KL
6	D1, D2, D3, D4, D5, D6	30V	Schottky diode, 1A	SOD-123	Diodes, Inc.	B130LAW-7-F
6	M1, M2, M3, M4, M5, M6	80V	N-channel MOSFET, 90A, Q <sub>G</sub> = 60nC, 11m $\Omega$ when V <sub>GS</sub> = 10V	TO-263	Analog Power	AM90N08-10B
1	LED1	50mW	Red LED	0805	Baihong	BL-HUE35A-AV-TRB
1	SW1	500mA	Switch slide SPDT, 12V	DIP	Wurth	450301014042
9	JP1, JP2, JP3, JP4, JP5, JP6, JP7, JP8, JP9	2.54mm	2-bit connector	DIP	Any	

**EVQ6532-V-00A BILL OF MATERIALS (continued)**

Qty	Ref	Value	Description	Package	Manufacturer	Manufacturer PN
6	JP1, JP3, JP4, JP6, JP7, JP9	2.54mm	Short jumper	DIP	Any	
1	CN1	2.54mm	10-bit connector	DIP	Any	
1	Hall Sensor	2.54mm	5-bit connector	DIP	Any	
5	VIN, VIN_GND, HAS, HBS, HCS	$\phi = 2\text{mm}$	Connector	DIP	Any	
12	OC_REF, nFAULT, VH, VH_GND, LAS, LBS, LCS, HAD, HBD, HCD, GND, GND	$\phi = 1\text{mm}$	Connector	DIP	Any	
1	U1	MPQ6532	60V, three-phase BLDC motor pre-driver	QFN-28 (4mmx 5mm)	MPS	MPQ6532GVE-AEC1



## REVISION HISTORY

Revision #	Revision Date	Description	Pages Updated
1.0	09/28/2021	Initial Release	-

**Notice:** The information in this document is subject to change without notice. Please contact MPS for current specifications. Users should warrant and guarantee that third-party Intellectual Property rights are not infringed upon when integrating MPS products into any application. MPS will not assume any legal responsibility for any said applications.