

PART NUMBER	REV	FIRST USED
466278-1	A	OBSOLETE
466278-2	A	OBSOLETE
466278-3	O	OBSOLETE
466278-4	O	OBSOLETE
466278-5	E	SUPERSEDED BY -8
466278-6	E	SUPERSEDED BY -7
466278-7	J	565435-5
466278-8	B	OBSOLETE
466278-9	L	354500-1

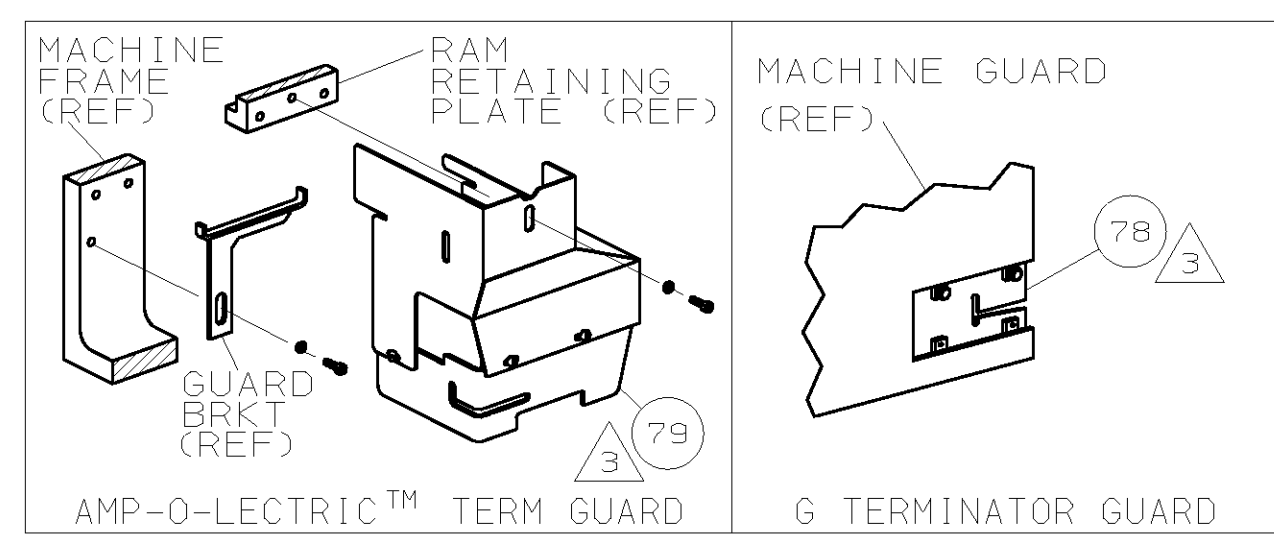

WIRE STRIP LENGTH		TERM APPL SPEC	FEED	APPL INSTRUCTION	SET UP GAGE	LAYOUT
.230-.250		114-2019	.890	408-8039	458638-1	779-8

CRIMPING DATA		WIRE SIZE	
PAD LTR	CRIMP HEIGHT	WIRE SIZE	
A	.079 ±.002 [2.01 ±0.05mm]	16	
B	.073 ±.002 [1.85 ±0.05mm]	18	
C	NOT	USED	
D	NOT	USED	
CRIMP	SIZE	TYPE	RANGE
WIRE	.110 [2.79mm]	F	18-16
INSUL	.155 [3.94mm]	F	∅ .130 MAX

QTY	REV	U/M	DWG SIZE	PART NO	DESCRIPTION	ITEM NO
7				BENCH MODEL K	AIRFEED	OBSOLETE
-9				LEADMAKER AND BENCH MODEL G	AIRFEED	

THIS DRAWING IS A CONTROLLED DOCUMENT.

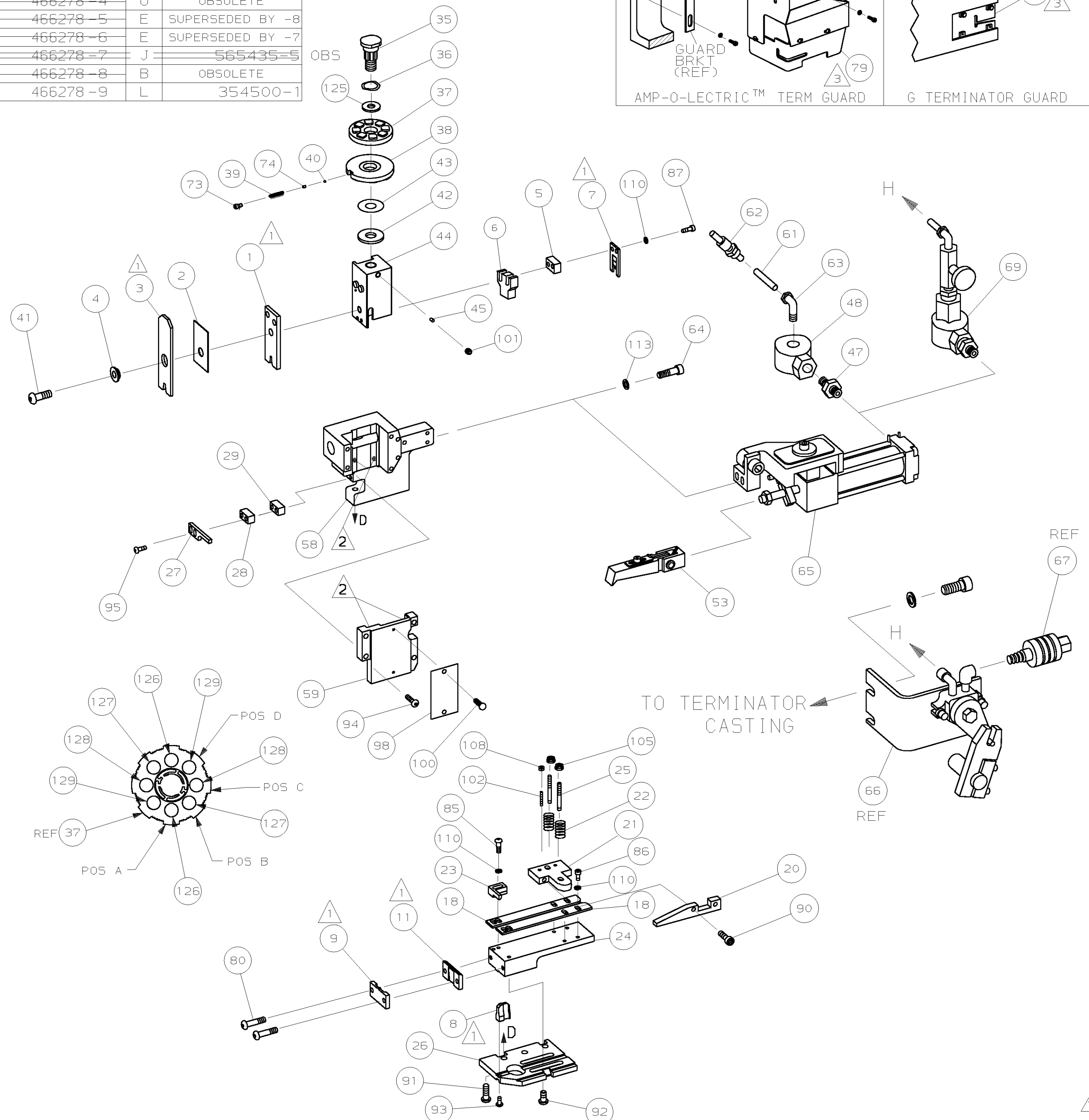

- 1 RECOMMENDED SPARE PARTS.
- 2 GREASE LIGHTLY.
- 3 GUARD MUST BE IN PLACE WHEN OPERATING APPLICATOR IN A BENCH MACHINE.
- 4 SEE DRAWING FOR COMPONENTS
- 5. DO NOT USE LUBRICANT ON TERMINAL STRIP.
- 6 FEED ON RECEPTACLE.
- ITEM 78 REQUIRED FOR G TERMINATOR ONLY.

QTY	REV	U/M	DWG SIZE	PART NO	DESCRIPTION	ITEM NO
-	-	-	-	-	-	129
-	-	-	-	-	-	128
2	2	-	C	7-354778-5	PIN, WIRE DISC (.2870)B	127
2	2	-	C	6-354778-3	PIN, WIRE DISC (.2810)A	126
1	-	-	A	986950-1	WASHER, FLAT PRECISION	125
-	-	-	-	-	-	124
-	-	-	-	-	-	123
-	-	-	-	-	-	122
-	-	-	-	-	-	121
-	-	-	-	-	-	120
-	-	-	-	-	-	119
-	-	-	-	-	-	118
-	-	-	-	-	-	117
-	-	-	-	-	-	116
-	-	-	-	-	-	115
-	-	-	-	-	-	114
2	2	-	A	21024-5	WASHER, LOCK (#10) AIR ASSY	113
-	-	-	-	-	-	112
-	-	-	-	-	-	111
10	7	-	A	21024-4	WASHER, LOCK (NO.8) SHEAR BL	110
-	-	-	-	-	-	109
2	2	-	A	21018-4	NUT, HEX (4-40) DRAG	108
-	-	-	-	-	-	107
-	-	-	-	-	-	106
2	2	-	A	21022-2	NUT, HEX 5L (8-32) DRAG STUD	105
-	-	-	-	-	-	104
-	-	-	-	-	-	103
2	2	-	A	2-21006-6	SCR, SKT SET (4-40x.62) DRAG	102
1	-	-	A	21009-2	SCR, SKT SET (1/4-20x.25)RAM	101
2	2	-	A	21017-2	SCR, DRIVE (#2x.19) ID PLATE	100
-	-	-	-	-	-	99
1	-	-	B	461264-1	PLATE, IDENTIFICATION	98
-	-	-	-	-	-	97
-	-	-	-	-	-	96
2	2	-	A	2-21000-9	SCR, SHC (8-32x.75) STRIPPER	95
4	4	-	A	2-21002-9	SCR, BHC (10-32x.75) CAP	94
1	-	-	A	22733-8	SCR, BHC (8-32x.38 LW) ANVIL	93
4	4	-	A	3-21002-3	SCR, BHC (1/4-20x.50) ST 6D PL	92
3	3	-	A	2-22733-8	SCR, BHC (1/4-20x.62) H5G	91
2	2	-	A	1-21000-3	SCR, SHC (4-40x.25)	90
-	-	-	-	-	-	89
-	-	-	-	-	-	88
2	2	-	A	2-21000-7	SCR, SHC (8-32x.50) SLUG BLADE	87
3	3	-	A	2-21000-6	SCR, SHC (8-32x.38) STRIP GUIDE	86
2	2	-	A	2-21000-8	SCR, BHC (8-32x.63) R STRIP GUIDE	85
-	-	-	-	-	-	84
-	-	-	-	-	-	83
-	-	-	-	-	-	82
-	-	-	-	-	-	81
2	2	-	A	3-21002-0	SCR, BHC (10-32x.88) SHEAR PL	80
-	-	-	A	455750-8	GUARD ASSY	79
REF	-	-	A	679532-1	INSERT, GUARD	78
-	-	-	-	-	-	77
-	-	-	-	-	-	76
-	-	-	-	-	-	75
1	-	-	A	690603-1	SPRING, ASSIST	74
1	-	-	A	23030-1	SCR, SKT CAP (6-32x.25) CP DSC	73
-	-	-	-	-	-	72
-	-	-	-	-	-	71

QTY	REV	U/M	DWG SIZE	PART NO	DESCRIPTION	ITEM NO
-	-	-	-	-	-	60
1	-	-	C	454220-1	CAP, RAM	59
1	-	-	D	453736-1	HOUSING	58
-	-	-	-	-	-	57
-	-	-	-	-	-	56
-	-	-	-	-	-	55
-	-	-	-	-	-	54
4	1	-	B	460680-2	FEED FINGER ASSY	53
-	-	-	-	-	-	52
-	-	-	-	-	-	51
-	-	-	-	-	-	50
-	-	-	-	-	-	49
1	-	-	A	22374-7	VALVE, QUICK EXHAUST	48
1	-	-	A	22304-1	NIPPLE, HEX 1/8 NPT	47
-	-	-	-	-	-	46
1	-	-	A	690191-1	PLUG, NYLON	45
1	-	-	C	455674-1	RAM	44
1	-	-	A	690125-1	WASHER, LAMINATED	43
1	-	-	A	690124-1	WASHER, RAM	42
1	-	-	A	7-21002-9	BOLT, CRIMPER (5/16-24x1.00)	41
1	-	-	A	23241-6	BALL, STEEL	40
1	-	-	A	690170-1	SPRING, COMPRESSION	39
1	-	-	C	690142-1	DISC, INSULATION	38
1	-	-	D	354777-1	WIRE DISC, PLASTIC	37
1	-	-	A	22480-5	WASHER, SPRING	36
1	-	-	B	690212-1	POST, RAM	35
-	-	-	-	-	-	34
-	-	-	-	-	-	33
-	-	-	-	-	-	32
-	-	-	-	-	-	31
-	-	-	-	-	-	30
1	-	-	B	2-690451-5	SPACER, STRIPPER	29
1	-	-	B	1-690451-2	SPACER, STRIPPER	28
1	-	-	A	240639-4	STRIPPER	27
1	-	-	D	455676-1	PLATE, BASE	26
2	2	-	A	22354-8	DRAG, STUD	25
1	-	-	B	455678-1	PLATE, STRIP GUIDE	24
1	-	-	C	240825-3	PLATE, STRIP HOLD DOWN	23
2	2	-	A	4-22281-1	SPRING, DRAG	22
1	-	-	A	464451-1	DRAG, STOCK	21
1	-	-	A	464452-4	DRAG, STOCK	20
-	-	-	-	-	-	19
2	2	-	C	454204-4	GUIDE, STRIP (FRONT)	18
-	-	-	-	-	-	17
-	-	-	-	-	-	16
-	-	-	-	-	-	15
-	-	-	-	-	-	14
-	-	-	-	-	-	13
-	-	-	-	-	-	12
1	1	-	B	240644-1	PLATE, REAR SHEAR	11
-	-	-	-	-	-	10
1	1	-	B	690482-4	PLATE, FRONT SHEAR	9
1	1	-	D	9-240655-7	ANVIL	8
1	1	-	B	690474-4	BLADE, SLUG	7
1	1	-	D	217573-1	HOLD DOWN, TERMINAL	6
1	1	-	C	4-240641-3	SPACER, SLUG BLADE	5
1	1	-	B	238009-1	SPACER, BLOCK CRIMPER	4
1	1	-	C	1-456134-2	CRIMPER, INSULATION	3
1	1	-	B	1-455888-9	SPACER, CRIMPER	2
1	1	-	C	1-456422-0	CRIMPER, WIRE	1

THIS DRAWING IS UNRELEASABLE... RELEASE FOR PUBLICATION... SEPT 15, 1999... BY AMP INCORPORATED. ALL RIGHTS RESERVED.

LOC A
D1ST 66

QTY	REV	U/M	DWG SIZE	PART NO	DESCRIPTION	ITEM NO
-9	-7	U/M	DWG SIZE	PART NO	DESCRIPTION	ITEM NO

PARTS LIST			PARTS LIST			
LI	ECN 0150-1228-04	TE 9-04	DIMENSIONS IN INCHES.	MATL	HT TR	FIN
L	ECN 0150-0203-00	TE 3-00	DO NOT SCALE PRINT.			
K	0150-9684-99	TE NOV99	TOLERANCES UNLESS OTHERWISE SPECIFIED:			
J	ECN 0150-9605-99	DS 9/99	2 PLC DEC ±.25	DR	5-22-95	APP T.BEDDICK
J	ECN 015A-0423-99	-	3 PLC DEC ±	CHK	5-22-95	REL 5/24/95
HI	0150-9588-99	BH 9/99	4 PLC DEC ±	C.ERISMAN	B. MORGAN	
H	0150-8168-97	TB 12-97	ANGLES ±			
G	0150-6779-96,0B5	EB 4-96	SURF TEXTURE:			
F	0150-6129-95,ADD -9	CE 5-95	REMOVE BURRS, BREAK SHARP EDGES R.015 MAX			
P/F	LTR	REVISION RECORD	APP	DATE		

NAME	END FEED HDM APPLICATOR	MACHINE REF	MINI APPL
SCALE	DWG NO 466278	SHEET	REV
		1 OF 1	L1

AMP Incorporated Harrisburg, PA 17105-3608