

MATERIAL NUMBER (STD.)	MATERIAL NUMBER (-50)	NO. OF CIRCUITS	A	B	C	D
386372202	386372302	2	43.4 (1.71)	11.13 (.438)	25.9 (1.02)	33.3 (1.31)
386372203	386372303	3	54.6 (2.15)	22.22 (.875)	37.1 (1.46)	44.5 (1.75)
386372204	386372304	4	65.7 (2.59)	33.35 (1.313)	48.3 (1.90)	55.6 (2.19)
386372205	386372305	5	76.7 (3.02)	44.45 (1.750)	59.2 (2.33)	66.5 (2.62)
386372206	386372306	6	87.9 (3.46)	55.57 (2.188)	70.4 (2.77)	77.7 (3.06)
386372207	386372307	7	99.1 (3.90)	66.67 (2.625)	81.5 (3.21)	88.9 (3.50)
386372208	386372308	8	110.2 (4.34)	77.80 (3.063)	92.7 (3.65)	100.0 (3.94)
386372209	386372309	9	121.2 (4.77)	88.90 (3.500)	103.6 (4.08)	111.0 (4.37)
386372210	386372310	10	132.3 (5.21)	100.03 (3.938)	114.8 (4.52)	122.2 (4.81)
386372211	386372311	11	143.5 (5.65)	111.13 (4.375)	125.9 (4.96)	133.4 (5.25)
386372212	386372312	12	154.7 (6.09)	122.25 (4.813)	137.2 (5.40)	144.5 (5.69)
386372213	386372313	13	165.6 (6.52)	133.35 (5.250)	148.1 (5.83)	155.4 (6.12)
386372214	386372314	14	176.8 (6.96)	144.45 (5.687)	159.3 (6.27)	166.6 (6.56)
386372215	386372315	15	188.0 (7.40)	155.58 (6.125)	170.4 (6.71)	177.8 (7.00)
386372216	386372316	16	199.1 (7.84)	166.70 (6.563)	181.6 (7.15)	189.0 (7.44)

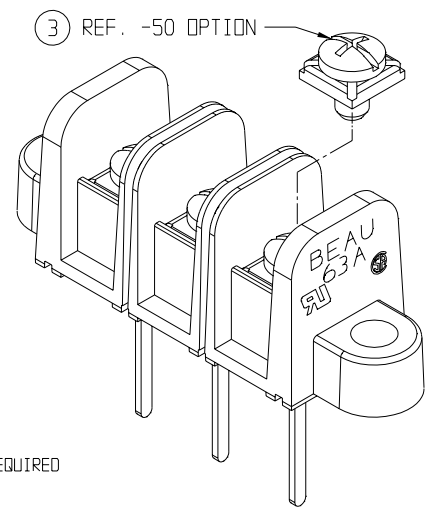
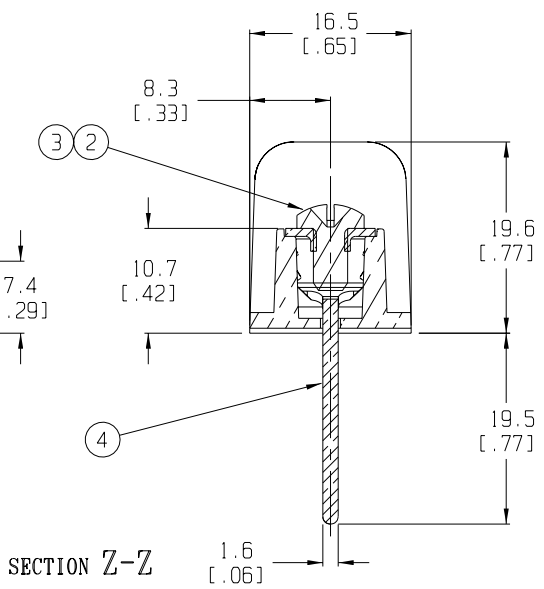
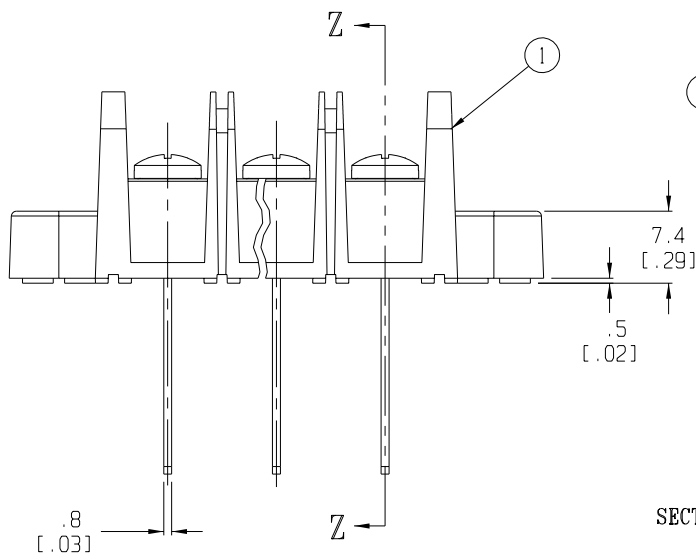

- NOTES:
1. MATERIAL: SEE TABLE
  2. FINISHES: SEE TABLE
  3. PRODUCT SPECIFICATION: NOT REQUIRED
  4. PACKAGING: NOT REQUIRED
  5. MATES WITH: NONE
  6. INCH DIMS ARE SHOWN IN PARENTHESIS (XXX)
  7. "XX" REFERS TO QTY. OF CIRCUITS

ITEM	QTY.	DESCRIPTION	MATERIAL	FINISH
4	XX	TERMINAL, WIRE WRAP, EXTRA LG.	BRASS	TIN PLATE
3	XX	PAN HD. SCREW & WASHER, 6-32	BRASS	BRT.ZINC PLATE
2	XX	BINDING HD. SCREW, 6-32	STEEL	BRT.ZINC PLATE
1	I	BARRIER TERMINAL STRIP	PVC	BLACK

ECO 11339  
 EC NO. RELEASE  
 R. STONE  
 CH K:  
 APPR:  
 A

DESCRIPTION  
 MAJOR  
 CRITICAL  
 SPC  
 S

REV

GENERAL TOLERANCES: (UNLESS SPECIFIED)	
4 PLACES	±.0015
3 PLACES	±.005
1 PLACE	±.01
ANGULAR: ±2°	

SCALE 2:1	DESIGN UNITS <input type="checkbox"/> mm <input checked="" type="checkbox"/> INCH
DRAWN BY & DATE R. STONE 3-26-03	
CHECKED BY & DATE	
APPROVED BY & DATE	

PROJECT NO. E-656

1	-
SHT	REV

DIMENSIONS:  
 mm  INCH  mm ONLY

TITLE:  
 63A SERIES BTS, 600V, WIRE WRAP  
 MTG ENDS (EXTRA LG.)

**molex** MOLEX INCORPORATED

CAD FILENAME 63A7XX-81-001	MATERIAL NO. SEE CHART	DRAWING NO. SD-38637-003	SHEET NO. 1 OF 1
-------------------------------	---------------------------	-----------------------------	---------------------

THIS DRAWING CONTAINS INFORMATION THAT IS PROPRIETARY TO MOLEX INCORPORATED AND SHOULD NOT BE USED WITHOUT WRITTEN PERMISSION.

SIZE  
B