

Tx Wireless Charging Coil Assembly



AWCCA-98T56H38-C01-B

Pb | **RoHS / RoHS II Compliant**

Moisture Sensitivity Level (MSL) – MSL = 1

FEATURES:

- Wireless Charging Transmitter Triple Coil Array
- Outline Dimensions: 98.0mm x 56.0mm x 3.8mm
- Linear Array of Primary Coils, 2 lower coils (12.0μH), 1 upper coil (11.5μH).
- For Tx applications working with 12V
- High permeability shielding to protect sensitive electronics
- Durable construction
- RoHS / RoHS II Compliant & Pb free.

APPLICATIONS:

- Wireless Charging Stations
- Automotive Industry (in car charging)
- Batteries Chargers
- Consumer Electronics Chargers
- Mobile Phone Charging Accessories
- Power Tool Charging Systems

DESCRIPTION & KEY ELECTRICAL SPECIFICATIONS

The AWCCA-98T56H38-C01-B Wireless Charging Coil is suitable for transmitter (Tx) applications. It is a 3 coil design with inductance of 12.0μH (2 lower coils), and 11.5uH (upper coil).

Maximum Ratings

Item	Value
Operating Temperature Range	T=-25°C ~ 85°C, RH≤ 90%.
Storage Temperature Range	-25°C~85°C, 70%RH (Max.)

Part Number	Inductance	DC Resistance	Q
AWCCA-98T56H38-C01-B	12μH ±10% (lower coils) 11.5μH ±10% (upper coils)	56mΩ ±20%	120 ±30% (lower coils) 110 ±30% (upper coils)
Test Condition	100KHz / 1V	20±15°C	100KHz / 1V
Test Environment	Temperature: 20±10°C, RH: 65% ±20% Equipment: Chroma11025		

Test Conditions : 20±15°C

PART IDENTIFICATION:

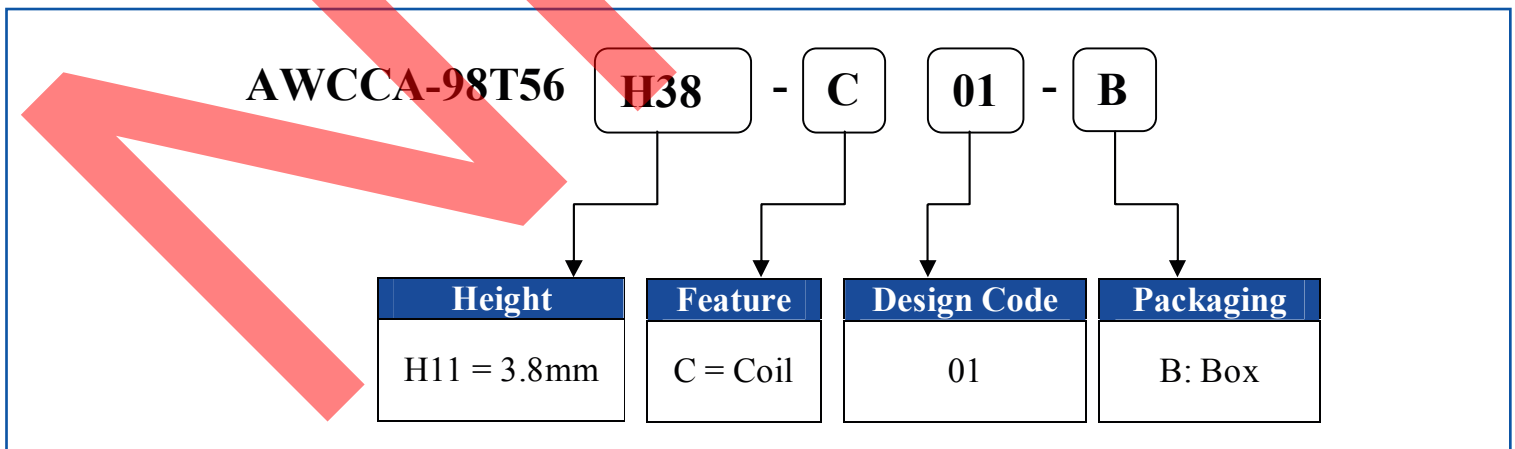

Tx Wireless Charging Coil Assembly

AWCCA-98T56H38-C01-B



RoHS / RoHS II Compliant



98 x 56 x 3.8mm

OUTLINE DIMENSIONS:

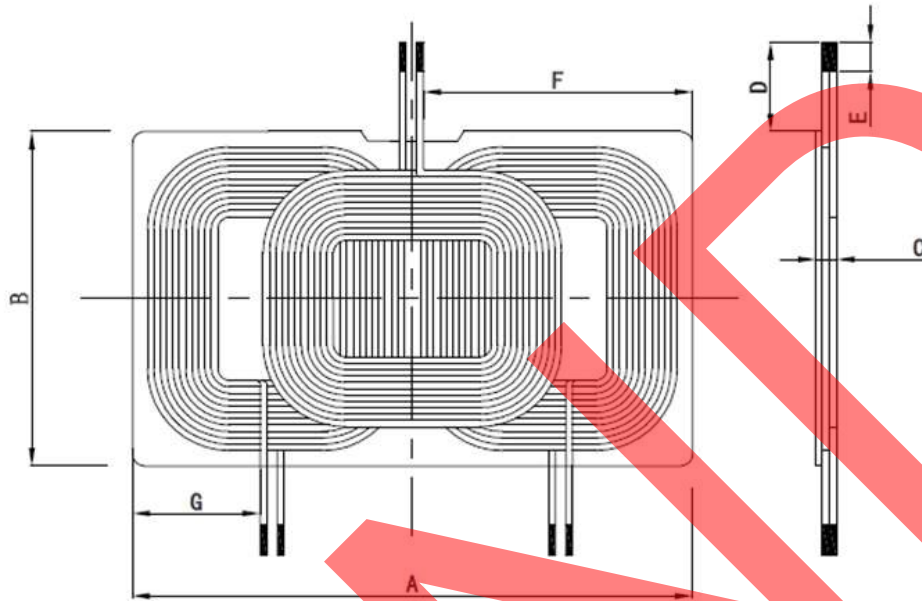

Item	A	B	C	D	E	F	G
Spec	98±1.0	56±1.0	3.8 Max	15 REF	5.0 REF	45.0 REF	20.0 REF

Winding Specifications

Number of Coils	Wire	Number of Turns	Inductance
3	∅ 17AWG (1.15mm) Type 2 Litz wire with 105 strands 40 AWG (0.08mm)	12	Lower 12uH±10%μH Upper 1.5uH±10%μH

Dimensions in mm

Wave Soldering Profile: Not suitable for wave soldering

Manual Soldering: 350°C Max, 3secs

Packaging: Box, 100pcs MOQ

Tx Wireless Charging Coil Assembly

AWCCA-98T56H38-C01-B



RoHS / RoHS II Compliant



98 x 56 x 3.8mm

STORAGE AND OPERATIONAL CONDITION:

Storage condition

- Recommended storage conditions: -25°C~85°C, 70%RH (Max.)
- Service life: Within the limits of six month from being produced.
- The appearance and solder ability should be check, if product is not in expiry date.

Operation Conditions

- Use condition limit: T=-25°C ~ 85°C, RH≤ 90%.

NOTE:

- The parts are manufactured in accordance with this specification. If other conditions and specifications which are required for this specification, please contact ABRACON for more information.
- ABRACON will supply the parts in accordance with this specification unless we receive a written request to modify prior to an order placement.
- In no case shall ABRACON be liable for any product failure from in appropriate handling or operation of the item beyond the scope of this specification.
- When changing your production process, please notify ABRACON immediately.
- ABRACON LLC's products are COTS – Commercial-Off-The-Shelf products; suitable for Commercial, Industrial and, where designated, Automotive Applications. ABRACON's products are not specifically designed for Military, Aviation, Aerospace, Lifedependant Medical applications or any application requiring high reliability where component failure could result in loss of life and/or property. For applications requiring high reliability and/or presenting an extreme operating environment, written consent and authorization from ABRACON LLC is required. Please contact ABRACON LLC for more information.
- All specifications and Marking will be subject to change without notice.

ATTENTION: Abracon Corporation's products are COTS – Commercial-Off-The-Shelf products; suitable for Commercial, Industrial and, where designated, Automotive Applications. Abracon's products are not specifically designed for Military, Aviation, Aerospace, Life-dependant Medical applications or any application requiring high reliability where component failure could result in loss of life and/or property. For applications requiring high reliability and/or presenting an extreme operating environment, written consent and authorization from Abracon Corporation is required. Please contact Abracon Corporation for more information.

ABRACON IS
ISO9001:2008
CERTIFIED



2 Faraday, Suite# B | Irvine | CA 92618 **Revised: 11.30.15**
Ph. 949.546.8000 | Fax. 949.546.8001
Visit www.abracon.com for Terms and Conditions of Sale