

Customer Information Sheet

DRAWING No.: M80-4C100F1-60-327

SHEET 2 OF 2

IF IN DOUBT - ASK

©

NOT TO SCALE

THIRD ANGLE PROJECTION

ALL DIMENSIONS IN mm

OBSOLETE

SPECIFICATIONS:

MATERIAL:
 MOULDING = GLASS-FILLED PPS, UL94V-0, BLACK
 JACKSCREW = STAINLESS STEEL
 POWER CONTACT
 BODY = COPPER ALLOY
 LATCHING COLLAR = BERYLLIUM COPPER

FINISH:
 POWER CONTACT
 BODY = GOLD
 LATCHING COLLAR = NICKEL

ELECTRICAL:
 POWER CONTACT:
 CURRENT RATING = 10A MAX WITH
 16AWG CONTACT AS SPECIFIED
 CONTACT RESISTANCE = 6 mΩ MAX
 WORKING VOLTAGE = 120V AC/DC
 VOLTAGE PROOF = 360V AC/DC
 INSULATION RESISTANCE = 100 MΩ MIN

MECHANICAL:
 DURABILITY = 500 OPERATIONS
 POWER CONTACT:
 INSERTION FORCE = 5N MAX
 WITHDRAWAL FORCE = 0.5N MIN

ENVIRONMENTAL:
 TEMPERATURE RANGE = -55°C TO +125°C

PACKING:
 BAG

FOR COMPLETE SPECIFICATION, SEE
 COMPONENT SPECIFICATION C005XX
 (LATEST ISSUE)

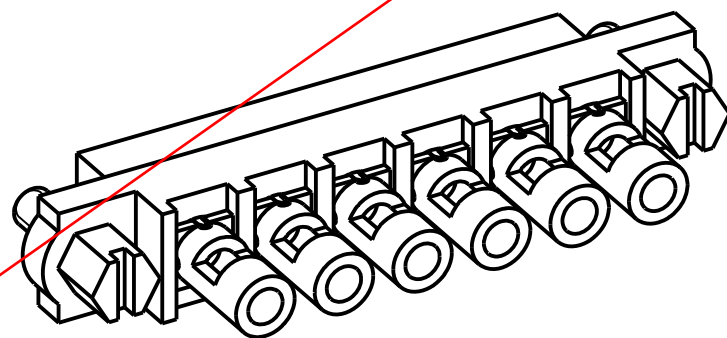
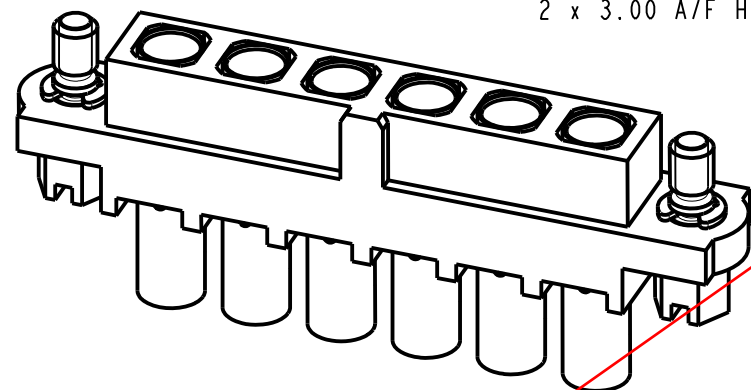
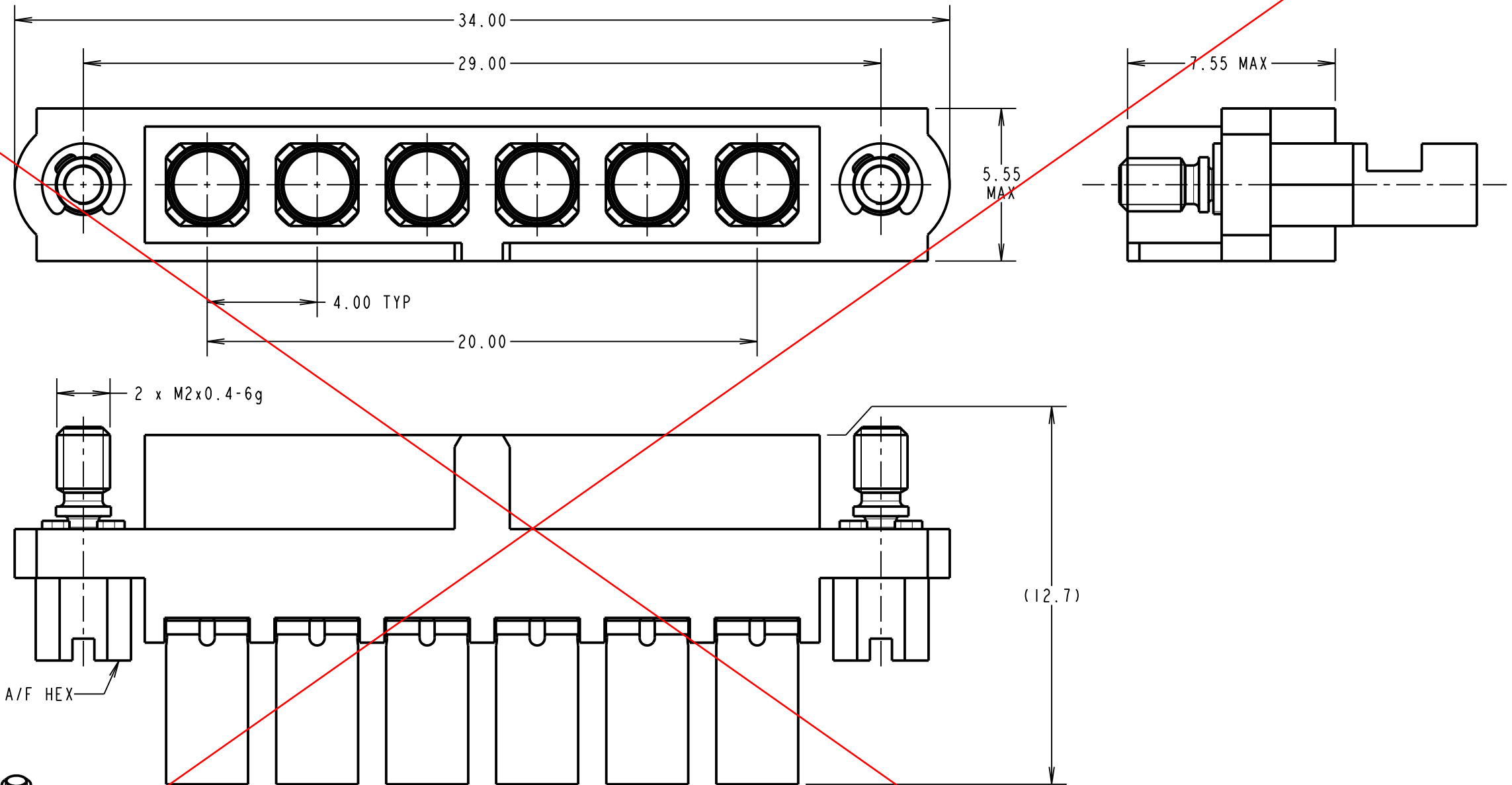

NOTES:

- CONNECTORS ARE SUPPLIED AS A KIT OF PARTS: MOULDING + JACKSCREWS AND POWER CONTACTS.
- FOR EXTRA POWER CONTACTS, USE PART NUMBER M80-327.
- POWER CONTACT WIRE, STRIP BY 5.00mm MINIMUM.
- INSTRUCTION SHEETS ARE AVAILABLE.

SM	1	24.08.10	10806
NAME	ISS.	DATE	C/NOTE
APPROVED: S. MCCULLAGH			
CHECKED: R. ADDE			
DRAWN: B. M. KENT			
CUSTOMER REF.:			
ASSEMBLY DRG:			

HARWIN			THIS DRAWING AND ANY INFORMATION OR DESCRIPTIVE MATTER SET OUT HEREON ARE CONFIDENTIAL AND COPYRIGHT PROPERTY OF THE HARWIN GROUP AND MUST NOT BE DISCLOSED, LOANED, COPIED OR USED FOR MANUFACTURING, TENDERING OR FOR ANY OTHER PURPOSE WITHOUT THEIR WRITTEN PERMISSION.	TOLERANCES X. = ±1mm X.X = ±0.25mm X.XX = ±0.10mm X.XXX = ±0.01mm ANGLES = ±5° UNLESS STATED	MATERIAL: SEE ABOVE FINISH: SEE ABOVE S/AREA: mm ²	TITLE: JACKSCREW DATAMATE MIXED TECHNOLOGY VERTICAL CRIMP FEMALE ASSEMBLY DRAWING NUMBER: M80-4C100F1-60-327	SHT 2 OF 2
HARWIN USA TEL: 603 893 5376 FAX: 603 893 5396 mis@harwin.com	HARWIN Europe (UK) TEL: 023 9231 4545 FAX: 023 9231 4590 mis@harwin.co.uk	HARWIN Asia TEL: +65 6 779 4909 FAX: +65 6 779 3868 mis@harwin.com.sg		SEE ABOVE	SEE ABOVE	SEE ABOVE	