

ADV7121/ADV7122

FEATURES

80 MHz Pipelined Operation
Triple 10-Bit D/A Converters
RS-343A/RS-170 Compatible Outputs
TTL Compatible Inputs
+5 V CMOS Monolithic Construction
40-Pin DIP Package (ADV7121)
44-Pin PLCC Package (ADV7122)
48-Lead TQFP (ADV7122)

APPLICATIONS

High Definition Television (HDTV)
High Resolution Color Graphics
CAE/CAD/CAM Applications
Image Processing
Instrumentation
Video Signal Reconstruction
Direct Digital Synthesis (DDS)
I/Q Modulation

SPEED GRADES

80 MHz
50 MHz
30 MHz

GENERAL DESCRIPTION

The ADV7121/ADV7122 (ADV[®]) is a video speed, digital-to-analog converter on a single monolithic chip. The part is specifically designed for high resolution color graphics and video systems including high definition television (HDTV). It is also ideal for any application requiring a low cost, high speed DAC function especially in communications. It consists of three, high speed, 10-bit, video D/A converters (RGB), a standard TTL input interface and high impedance, analog output, current sources.

The ADV7121/ADV7122 has three separate, 10-bit, pixel input ports, one each for red, green and blue video data. A single +5 V power supply, an external 1.23 V reference and pixel clock input is all that is required to make the part operational. The ADV7122 has additional video control signals, composite SYNC and BLANK.

The ADV7121/ADV7122 is capable of generating RGB video output signals which are compatible with RS-343A, RS-170 and most proposed production system HDTV video standards, including SMPTE 240M.

The ADV7121/ADV7122 is fabricated in a +5 V CMOS process. Its monolithic CMOS construction ensures greater functionality with low power dissipation. The ADV7121 is packaged in a 0.6", 40-pin plastic DIP package. The ADV7122 is pack-

ADV is a registered trademark of Analog Devices, Inc.

*Speed grades up to 140 MHz are also available on special request.

Please contact Analog Devices or its representatives for details.

REV. B

Information furnished by Analog Devices is believed to be accurate and reliable. However, no responsibility is assumed by Analog Devices for its use, nor for any infringements of patents or other rights of third parties which may result from its use. No license is granted by implication or otherwise under any patent or patent rights of Analog Devices.

ADV7121 FUNCTIONAL BLOCK DIAGRAM

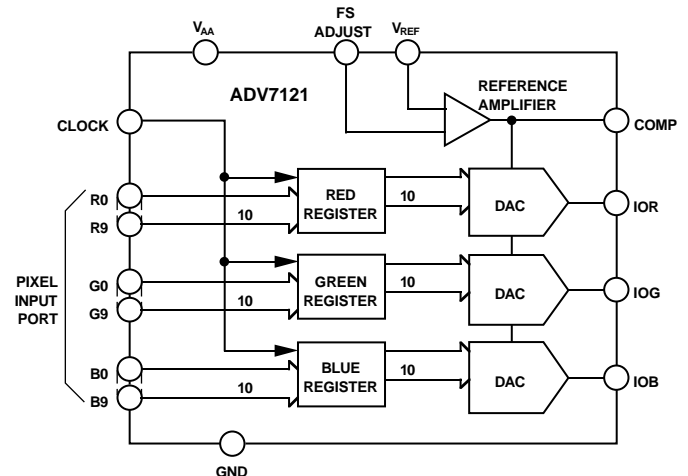

ADV7122 FUNCTIONAL BLOCK DIAGRAM

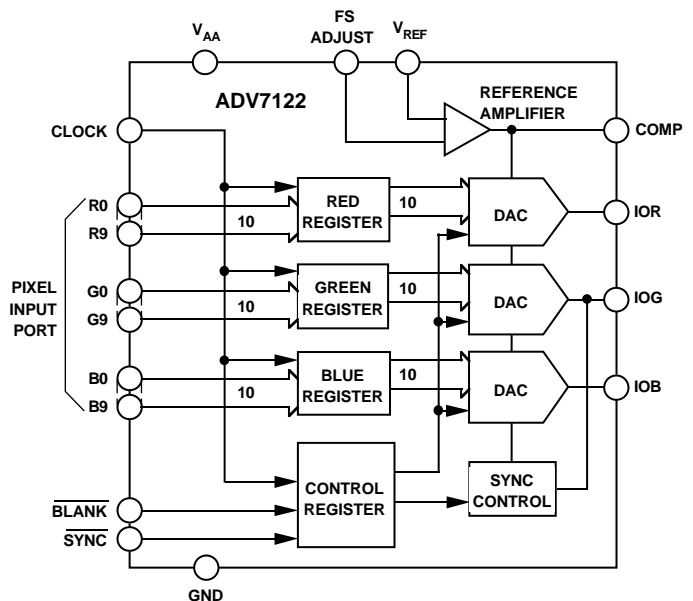

aged in a 44-pin plastic leaded (J-lead) chip carrier, PLCC, and 48-lead thin quad flatpack (TQFP).

PRODUCT HIGHLIGHTS

1. Fast video refresh rate, 80 MHz.
2. Guaranteed monotonic to 10 bits. Ten bits of resolution allows for implementation of linearization functions such as gamma correction and contrast enhancement.
3. Compatible with a wide variety of high resolution color graphics systems including RS-343A/RS-170 and the proposed SMPTE 240M standard for HDTV.

© Analog Devices, Inc., 1996

ADV7121–SPECIFICATIONS ($V_{AA} = +5\text{ V} \pm 5\%$; $V_{REF} = +1.235\text{ V}$; $R_L = 3.75\ \Omega$, $C_L = 10\text{ pF}$; $R_{SET} = 560\ \Omega$. All Specifications T_{MIN} to T_{MAX} ¹ unless otherwise noted.)

Parameter	K Version	Units	Test Conditions/Comments
STATIC PERFORMANCE			
Resolution (Each DAC)	10	Bits	Guaranteed Monotonic Max Gray Scale Current = $(V_{REF} * 7,969/R_{SET})\text{ mA}$
Accuracy (Each DAC)			
Integral Nonlinearity, INL	± 2	LSB max	
Differential Nonlinearity, DNL	± 1	LSB max	
Gray Scale Error	± 5	% Gray Scale max	
Coding		Binary	
DIGITAL INPUTS			
Input High Voltage, V_{INH}	2	V min	$V_{IN} = 0.4\text{ V or }2.4\text{ V}$
Input Low Voltage, V_{INL}	0.8	V max	
Input Current, I_{IN}	± 1	$\mu\text{A max}$	
Input Capacitance, C_{IN}^2	10	pF max	
ANALOG OUTPUTS			
Gray Scale Current Range	15 22	mA min mA max	Typically 17.62 mA Typically 5 μA Typically 2% $I_{OUT} = 0\text{ mA}$
Output Current			
White Level	16.74 18.50	mA min mA max	
Black Level	0	$\mu\text{A min}$	
LSB Size	50	$\mu\text{A max}$	
DAC to DAC Matching	17.28	$\mu\text{A typ}$	
Output Compliance, V_{OC}	5	% max	
Output Compliance, V_{OC}	-1 +1.4	V min V max	
Output Impedance, R_{OUT}^2	100	k Ω typ	
Output Capacitance, C_{OUT}^2	30	pF max	
VOLTAGE REFERENCE			
Voltage Reference Range, V_{REF}	1.14/1.26	V min/V max	$V_{REF} = 1.235\text{ V}$ for Specified Performance
Input Current, I_{VREF}	-5	mA typ	
POWER REQUIREMENTS			
V_{AA}	5	V nom	Typically 80 mA: 80 MHz Parts Typically 70 mA: 50 MHz & 35 MHz Parts Typically 0.12 %/‰: $f = 1\text{ kHz}$, COMP = 0.1 μF Typically 400 mW: 80 MHz Parts Typically 350 mW: 50 MHz & 35 MHz Parts
I_{AA}	125	mA max	
	100	mA max	
Power Supply Rejection Ratio ²	0.5	%/‰ max	
Power Dissipation	625	mW max	
	500	mW max	
DYNAMIC PERFORMANCE			
Glitch Impulse ^{2, 3}	50	pV secs typ	Typically 1 ns
DAC Noise ^{2, 3, 4}	200	pV secs typ	
Analog Output Skew	2	ns max	

NOTES

¹Temperature range (T_{MIN} to T_{MAX}): 0°C to +70°C.

²Sample tested at +25°C to ensure compliance.

³TTL input values are 0 to 3 volts, with input rise/fall times $\leq 3\text{ ns}$, measured between the 10% and 90% points. Timing reference points at 50% for inputs and outputs. See timing notes in Figure 1.

⁴This includes effects due to clock and data feedthrough as well as RGB analog crosstalk.

Specifications subject to change without notice.

ADV7122—SPECIFICATIONS

($V_{AA} = +5\text{ V} \pm 5\%$; $V_{REF} = +1.235\text{ V}$; $R_L = 37.5\ \Omega$, $C_L = 10\text{ pF}$; $R_{SET} = 560\ \Omega$. All Specifications T_{MIN} to T_{MAX} ¹ unless otherwise noted.)

Parameter	K Version	Units	Test Conditions/Comments
STATIC PERFORMANCE			
Resolution (Each DAC)	10	Bits	Guaranteed Monotonic Max Gray Scale Current: $I_{OG} = (V_{REF} * 12.082 / R_{SET})\text{ mA}$ $I_{OR}, I_{OB} = (V_{REF} * 8.627 / R_{SET})\text{ mA}$
Accuracy (Each DAC)			
Integral Nonlinearity, INL	± 2	LSB max	
Differential Nonlinearity, DNL	± 1	LSB max	
Gray Scale Error	± 5	% Gray Scale max	
Coding		Binary	
DIGITAL INPUTS			
Input High Voltage, V_{INH}	2	V min	$V_{IN} = 0.4\text{ V or } 2.4\text{ V}$
Input Low Voltage, V_{INL}	0.8	V max	
Input Current, I_{IN}	± 1	$\mu\text{A max}$	
Input Capacitance, C_{IN} ²	10	pF max	
ANALOG OUTPUTS			
Gray Scale Current Range	15 22	mA min mA max	
Output Current			
White Level Relative to Blank	17.69 20.40	mA min mA max	Typically 19.05 mA
White Level Relative to Black	16.74 18.50	mA min mA max	Typically 17.62 mA
Black Level Relative to Blank	0.95 1.90	mA min mA max	Typically 1.44 mA
Black Level on IOR, IOB	0 50	$\mu\text{A min}$ $\mu\text{A max}$	Typically 5 μA
Black Level on IOG	6.29 9.5	mA min mA max	Typically 7.62 mA
Sync Level on IOG	0 50	$\mu\text{A min}$ $\mu\text{A max}$	Typically 5 μA
LSB Size	17.28	$\mu\text{A typ}$	
DAC to DAC Matching	5	% max	Typically 2%
Output Compliance, V_{OC}	-1 +1.4	V min V max	
Output Impedance, R_{OUT} ²	100	k Ω typ	
Output Capacitance, C_{OUT} ²	30	pF max	$I_{OUT} = 0\text{ mA}$
VOLTAGE REFERENCE			
Voltage Reference Range, V_{REF}	1.14/1.26	V min/V max	$V_{REF} = 1.235\text{ V}$ for Specified Performance
Input Current, I_{VREF}	-5	mA typ	
POWER REQUIREMENTS			
V_{AA}	5	V nom	
I_{AA}	125 100	mA max mA max	Typically 80 mA: 80 MHz Parts Typically 70 mA: 50 MHz & 35 MHz Parts
Power Supply Rejection Ratio ²	0.5	%/1% max	Typically 0.12%/1%: $f = 1\text{ kHz}$, $COMP = 0.01\ \mu\text{F}$
Power Dissipation	625 500	mW max mW max	Typically 400 mW: 80 MHz Parts Typically 350 mW: 50 MHz & 35 MHz Parts
DYNAMIC PERFORMANCE			
Glitch Impulse ^{2,3}	50	pV secs typ	Typically 1 ns
DAC Noise ^{2,3,4}	200	pV secs typ	
Analog Output Skew	2	ns max	

NOTES¹Temperature range (T_{MIN} to T_{MAX}) 0°C to +70°C.²Sample tested at +25°C to ensure compliance.³TTL input values are 0 to 3 volts, with input rise/fall times $\leq 3\text{ ns}$, measured between the 10% and 90% points. Timing reference points at 50% for inputs and outputs. See timing notes in Figure 1.⁴This includes effects due to clock and data feedthrough as well as RGB analog crosstalk.

Specifications subject to change without notice

ADV7121/ADV7122

TIMING CHARACTERISTICS¹ ($V_{AA} = +5\text{ V} \pm 5\%$; $V_{REF} = +1.235\text{ V}$; $R_L = 37.5\ \Omega$, $C_L = 10\text{ pF}$; $R_{SET} = 560\ \Omega$. All Specifications T_{MIN} to T_{MAX} ² unless otherwise noted.)

Parameter	80 MHz Version	50 MHz Version	30 MHz Version	Units	Conditions/Comments
fmax	80	50	30	MHz max	Clock Rate
t ₁	3	6	8	ns min	Data & Control Setup Time
t ₂	2	2	2	ns min	Data & Control Hold Time
t ₃	12.5	20	33.3	ns min	Clock Cycle Time
t ₄	4	7	9	ns min	Clock Pulse Width High Time
t ₅	4	7	9	ns min	Clock Pulse Width Low Time
t ₆	30	30	30	ns max	Analog Output Delay
	20	20	20	ns typ	
t ₇	3	3	3	ns max	Analog Output Rise/Fall Time
t ₈ ³	12	15	15	ns typ	Analog Output Transition Time

NOTES

¹TTL input values are 0 to 3 volts, with input rise/fall times ≤ 3 ns, measured between the 10% and 90% points. Timing reference points at 50% for inputs and outputs. See timing notes in Figure 1.

²Temperature range (T_{MIN} to T_{MAX}): 0°C to +70°C.

³Sample tested at +25°C to ensure compliance.

Specifications subject to change without notice.

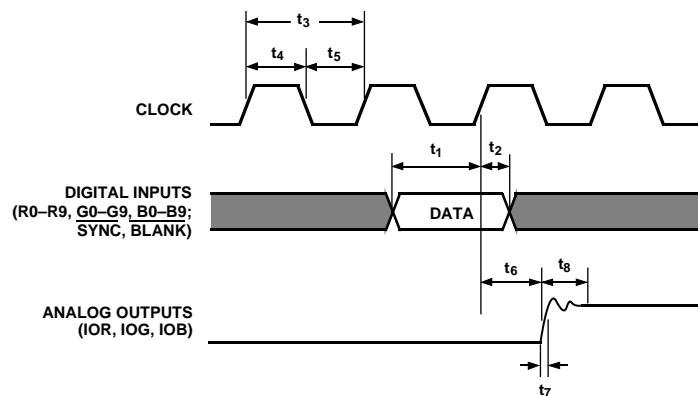

NOTES

1. OUTPUT DELAY (t_6) MEASURED FROM THE 50% POINT OF THE RISING EDGE OF THE CLOCK TO THE 50% POINT OF FULL-SCALE TRANSITION.
2. TRANSITION TIME (t_8) MEASURED FROM THE 50% POINT OF FULL-SCALE TRANSITION TO WITHIN 2% OF THE FINAL OUTPUT VALUE.
3. OUTPUT RISE/FALL TIME (t_7) MEASURED BETWEEN THE 10% AND 90% POINTS OF FULL-SCALE TRANSITION.

Figure 1. Video Input/Output Timing

RECOMMENDED OPERATING CONDITIONS

Parameter	Symbol	Min	Typ	Max	Units
Power Supply	V_{AA}	4.75	5.00	5.25	Volts
Ambient Operating Temperature	T_A	0		+70	°C
Output Load	R_L		37.5		Ω
Reference Voltage	V_{REF}	1.14	1.235	1.26	Volts

ABSOLUTE MAXIMUM RATINGS¹

V _{AA} to GND	+7 V
Voltage on Any Digital Pin	GND -0.5 V to V _{AA} + 0.5 V
Ambient Operating Temperature (T _A)	0°C to +70°C
Storage Temperature (T _S)	-65°C to +150°C
Junction Temperature (T _J)	+150°C
Soldering Temperature (5 secs)	220°C
Vapor Phase Soldering (1 minute)	220°C
IOR, IOB, IOG to GND ²	0 V to V _{AA}

NOTES

¹Stresses above those listed under “Absolute Maximum Ratings” may cause permanent damage to the device. This is a stress rating only and functional operation of the device at these or any other conditions above those listed in the operational sections of this specification is not implied. Exposure to absolute maximum rating conditions for extended periods may affect device reliability.

²Analog output short circuit to any power supply or common can be of an indefinite duration.

PIN CONFIGURATIONS

DIP (N-40A) Package

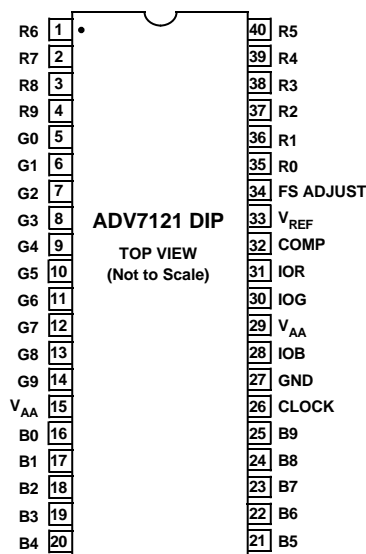

PLCC (P-44A) Package

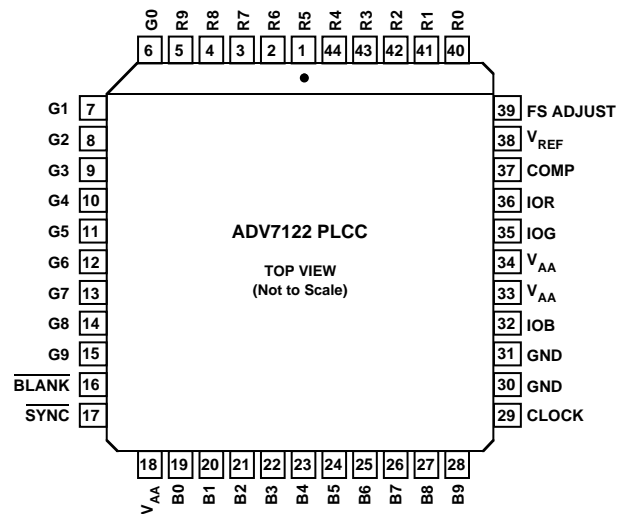

ORDERING GUIDE

Model	Speed	Temperature Range*	Package Description	Package Option
ADV7121KN80	80 MHz	0°C to +70°C	40-Pin Plastic DIP	N-40A
ADV7121KN50	50 MHz	0°C to +70°C	40-Pin Plastic DIP	N-40A
ADV7121KN30	30 MHz	0°C to +70°C	40-Pin Plastic DIP	N-40A
ADV7122KP80	80 MHz	0°C to +70°C	44-Lead Plastic Leaded Chip Carrier (PLCC)	P-44A
ADV7122KP50	50 MHz	0°C to +70°C	44-Lead Plastic Leaded Chip Carrier (PLCC)	P-44A
ADV7122KP30	30 MHz	0°C to +70°C	44-Lead Plastic Leaded Chip Carrier (PLCC)	P-44A
ADV7122KST50	50 MHz	0°C to +70°C	48-Lead Thin Quad Flatpack (TQFP)	ST-48
ADV7122KST30	30 MHz	0°C to +70°C	48-Lead Thin Quad Flatpack (TQFP)	ST-48

*Industrial Temperature range (-40°C to +85°C) parts are also available to special ranges. Please contact your local Analog Devices representative.

CAUTION

ESD (electrostatic discharge) sensitive device. Electrostatic charges as high as 4000 V readily accumulate on the human body and test equipment and can discharge without detection. Although the ADV7121/ADV7122 feature proprietary ESD protection circuitry, permanent damage may occur on devices subjected to high energy electrostatic discharges. Therefore, proper ESD precautions are recommended to avoid performance degradation or loss of functionality.



PIN FUNCTION DESCRIPTION

Pin Mnemonic	Function
$\overline{\text{BLANK}}^*$	Composite blank control input (TTL compatible). A logic zero on this control input drives the analog outputs, IOR, IOB and IOG, to the blanking level. The $\overline{\text{BLANK}}$ signal is latched on the rising edge of CLOCK. While $\overline{\text{BLANK}}$ is a logical zero, the R0–R9, G0–G9 and B0–B9 pixel inputs are ignored.
$\overline{\text{SYNC}}^*$	Composite sync control input (TTL compatible). A logical zero on the $\overline{\text{SYNC}}$ input switches off a 40 IRE current source. This is internally connected to the IOG analog output. $\overline{\text{SYNC}}$ does not override any other control or data input, therefore, it should only be asserted during the blanking interval. $\overline{\text{SYNC}}$ is latched on the rising edge of CLOCK. If sync information is not required on the green channel, the $\overline{\text{SYNC}}$ input should be tied to logical zero.
CLOCK	Clock input (TTL compatible). The rising edge of CLOCK latches the R0–R9, G0–G9, B0–B9, $\overline{\text{SYNC}}$ and $\overline{\text{BLANK}}$ pixel and control inputs. It is typically the pixel clock rate of the video system. CLOCK should be driven by a dedicated TTL buffer.
R0–R9, G0–G9, B0–B9	Red, green and blue pixel data inputs (TTL compatible). Pixel data is latched on the rising edge of CLOCK. R0, G0 and B0 are the least significant data bits. Unused pixel data inputs should be connected to either the regular PCB power or ground plane.
IOR, IOG, IOB	Red, green, and blue current outputs. These high impedance current sources are capable of directly driving a doubly terminated 75 Ω coaxial cable. All three current outputs should have similar output loads whether or not they are all being used.
FS ADJUST	Full-scale adjust control. A resistor (R_{SET}) connected between this pin and GND, controls the magnitude of the full-scale video signal. Note that the IRE relationships are maintained, regardless of the full-scale output current. The relationship between R_{SET} and the full-scale output current on IOG (assuming I_{SYNC} is connected to IOG) is given by: $R_{\text{SET}} (\Omega) = 12,082 \times V_{\text{REF}} (\text{V}) / \text{IOG} (\text{mA})$ The relationship between R_{SET} and the full-scale output current on IOR, IOG and IOB is given by: $\text{IOG}^* (\text{mA}) = 12,082 \times V_{\text{REF}} (\text{V}) / R_{\text{SET}} (\Omega) \quad (\overline{\text{SYNC}} \text{ being asserted})$ $\text{IOR, IOB} (\text{mA}) = 8,628 \times V_{\text{REF}} (\text{V}) / R_{\text{SET}} (\Omega)$ The equation for IOG will be the same as that for IOR and IOB when $\overline{\text{SYNC}}$ is not being used, i.e., $\overline{\text{SYNC}}$ tied permanently low. For the ADV7121, all three analog output currents are as described by: $\text{IOR, IOG, IOB} (\text{mA}) = 7,969 \times V_{\text{REF}} (\text{V}) / R_{\text{SET}} (\Omega)$
COMP	Compensation pin. This is a compensation pin for the internal reference amplifier. A 0.1 μF ceramic capacitor must be connected between COMP and V_{AA} .
V_{REF}	Voltage reference input. An external 1.23 V voltage reference must be connected to this pin. The use of an external resistor divider network is not recommended. A 0.1 μF decoupling ceramic capacitor should be connected between V_{REF} and V_{AA} .
V_{AA}	Analog power supply (5 V \pm 5%). All V_{AA} pins on the ADV7121/ADV7122 must be connected.
GND	Ground. All GND pins must be connected.

* $\overline{\text{SYNC}}$ and $\overline{\text{BLANK}}$ functions are not provided on the ADV7121.

TERMINOLOGY

Blanking Level

The level separating the $\overline{\text{SYNC}}$ portion from the video portion of the waveform. Usually referred to as the front porch or back porch. At 0 IRE units, it is the level which will shut off the picture tube, resulting in the blackest possible picture.

Color Video (RGB)

This usually refers to the technique of combining the three primary colors of red, green and blue to produce color pictures within the usual spectrum. In RGB monitors, three DACs are required, one for each color.

Sync Signal ($\overline{\text{SYNC}}$)

The position of the composite video signal which synchronizes the scanning process.

Gray Scale

The discrete levels of video signal between reference black and reference white levels. A 10-bit DAC contains 1024 different levels, while an 8-bit DAC contains 256.

Raster Scan

The most basic method of sweeping a CRT one line at a time to generate and display images.

Reference Black Level

The maximum negative polarity amplitude of the video signal.

Reference White Level

The maximum positive polarity amplitude of the video signal.

Sync Level

The peak level of the $\overline{\text{SYNC}}$ signal.

Video Signal

That portion of the composite video signal which varies in gray scale levels between reference white and reference black. Also referred to as the picture signal, this is the portion which may be visually observed.

CIRCUIT DESCRIPTION & OPERATION

The ADV7121/ADV7122 contains three 10-bit D/A converters, with three input channels, each containing a 10-bit register. Also integrated on board the part is a reference amplifier. CRT control functions $\overline{\text{BLANK}}$ and $\overline{\text{SYNC}}$ are integrated on board the ADV7122.

Digital Inputs

Thirty bits of pixel data (color information) R0–R9, G0–G9 and B0–B9 are latched into the device on the rising edge of each clock cycle. This data is presented to the three 10-bit DACs and is then converted to three analog (RGB) output waveforms. See Figure 2.

The ADV7122 has two additional control signals, which are latched to the analog video outputs in a similar fashion. $\overline{\text{BLANK}}$ and $\overline{\text{SYNC}}$ are each latched on the rising edge of $\overline{\text{CLOCK}}$ to maintain synchronization with the pixel data stream.

The $\overline{\text{BLANK}}$ and $\overline{\text{SYNC}}$ functions allow for the encoding of these video synchronization signals onto the RGB video output. This is done by adding appropriately weighted current sources to the analog outputs, as determined by the logic levels on the $\overline{\text{BLANK}}$ and $\overline{\text{SYNC}}$ digital inputs. Figure 3 shows the analog output, RGB video waveform of the ADV7121/ADV7122. The influence of $\overline{\text{SYNC}}$ and $\overline{\text{BLANK}}$ on the analog video waveform is illustrated.

Table I details the resultant effect on the analog outputs of $\overline{\text{BLANK}}$ and $\overline{\text{SYNC}}$.

All these digital inputs are specified to accept TTL logic levels.

Clock Input

The $\overline{\text{CLOCK}}$ input of the ADV7121/ADV7122 is typically the pixel clock rate of the system. It is also known as the dot rate. The dot rate, and hence the required $\overline{\text{CLOCK}}$ frequency, will be determined by the on-screen resolution, according to the following equation:

$$\text{Dot Rate} = (\text{Horiz Res}) \times (\text{Vert Res}) \times (\text{Refresh Rate}) / (\text{Retrace Factor})$$

Horiz Res = Number of Pixels/Line.

Vert Res = Number of Lines/Frame.

Refresh Rate = Horizontal Scan Rate. This is the rate at which the screen must be refreshed, typically 60 Hz for a noninterlaced system or 30 Hz for an interlaced system.

Retrace Factor = Total Blank Time Factor. This takes into account that the display is blanked for a certain fraction of the total duration of each frame (e.g., 0.8).

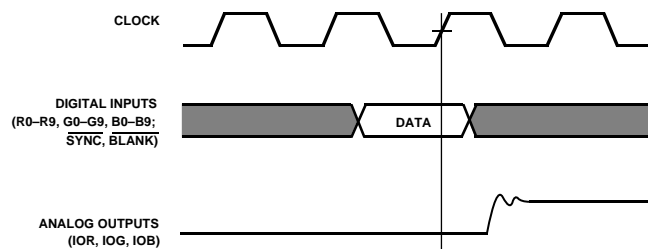

Figure 2. Video Data Input/Output

ADV7121/ADV7122

If we, therefore, have a graphics system with a 1024×1024 resolution, a noninterlaced 60 Hz refresh rate and a retrace factor of 0.8, then:

$$\begin{aligned} \text{Dot Rate} &= 1024 \times 1024 \times 60/0.8 \\ &= 78.6 \text{ MHz} \end{aligned}$$

The required CLOCK frequency is thus 78.6 MHz.

All video data and control inputs are latched into the ADV7121/ADV7122 on the rising edge of CLOCK, as previously described in the “Digital Inputs” section. It is recommended that the CLOCK input to the ADV7121/ADV7122 be driven by a TTL buffer (e.g., 74F244).

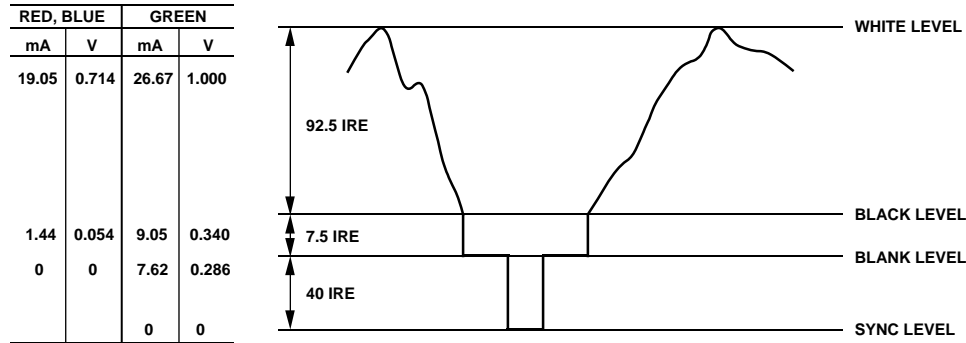

NOTES

1. OUTPUTS CONNECTED TO A DOUBLY TERMINATED 75Ω LOAD.
2. $V_{REF} = 1.235V$, $R_{SET} = 560\Omega$.
3. RS-343A LEVELS AND TOLERANCES ASSUMED ON ALL LEVELS.

Figure 3. RGB Video Output Waveform

Table Ia. Video Output Truth Table for the ADV7122

Description	IOG (mA)*	IOR, IOB (mA)	$\overline{\text{SYNC}}$	$\overline{\text{BLANK}}$	DAC Input Data
WHITE LEVEL	26.67	19.05	1	1	3FFH
VIDEO	video + 9.05	video + 1.44	1	1	data
VIDEO to BLANK	video + 1.44	video + 1.44	0	1	data
BLACK LEVEL	9.05	1.44	1	1	00H
BLACK to BLANK	1.44	1.44	0	1	00H
BLANK LEVEL	7.62	0	1	0	xxH
SYNC LEVEL	0	0	0	0	xxH

*Typical with full-scale IOG = 26.67 mA. $V_{REF} = 1.235 V$, $R_{SET} = 560 \Omega$, I_{SYNC} connected to IOG.

Table Ib. Video Output Truth Table for the ADV7121

Description	IOR, IOG, IOB (mA)*	DAC Input Data
WHITE LEVEL	17.62	3FF
VIDEO	video	data
VIDEO to BLACK	video	data
BLACK LEVEL	0	00H

*Typical with full scale = 17.62 mA. $V_{REF} = 1.235 V$, $R_{SET} = 560 \Omega$.

Video Synchronization & Control

The ADV7122 has a single composite sync ($\overline{\text{SYNC}}$) input control. Many graphics processors and CRT controllers have the ability of generating horizontal sync (HSYNC), vertical sync (VSYNC) and composite $\overline{\text{SYNC}}$.

In a graphics system which does not automatically generate a composite $\overline{\text{SYNC}}$ signal, the inclusion of some additional logic circuitry will enable the generation of a composite $\overline{\text{SYNC}}$ signal.

The sync current is internally connected directly to the IOG output, thus encoding video synchronization information onto the green video channel. If it is not required to encode sync information onto the ADV7122, the $\overline{\text{SYNC}}$ input should be tied to logic low.

Reference Input

An external 1.23 V voltage reference is required to drive the ADV7121/ADV7122. The AD589 from Analog Devices is an ideal choice of reference. It is a two-terminal, low cost, temperature compensated bandgap voltage reference which provides a fixed 1.23 V output voltage for input currents between 50 μA and 5 mA. Figure 4 shows a typical reference circuit connection diagram. The voltage reference gets its current drive from the ADV7121/ADV7122's V_{AA} through an onboard 1 k Ω resistor to the V_{REF} pin. A 0.1 μF ceramic capacitor is required between the COMP pin and V_{AA} . This is necessary so as to provide compensation for the internal reference amplifier.

A resistance R_{SET} connected between FS ADJUST and GND determines the amplitude of the output video level according to Equations 1 and 2 for the ADV7122 and Equation 3 for the ADV7121:

$$IOG^* (mA) = 12,082 \times V_{\text{REF}} (V) / R_{\text{SET}} (\Omega) \tag{1}$$

$$IOR, IOB (mA) = 8,628 \times V_{\text{REF}} (V) / R_{\text{SET}} (\Omega) \tag{2}$$

$$IOR, IOG, IOB (mA) = 7,969 \times V_{\text{REF}} (V) / R_{\text{SET}} (\Omega) \tag{3}$$

*Only applies to the ADV7122 when $\overline{\text{SYNC}}$ is being used. If $\overline{\text{SYNC}}$ is not being encoded onto the green channel, then Equation 1 will be similar to Equation 2.

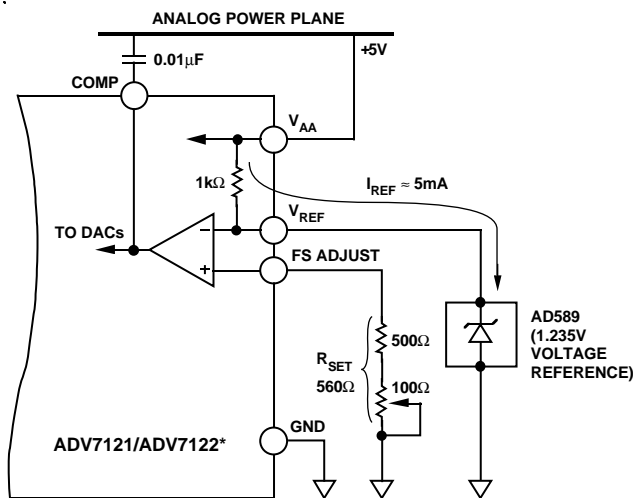

*ADDITIONAL CIRCUITRY, INCLUDING DECOUPLING COMPONENTS, EXCLUDED FOR CLARITY

Figure 4. Reference Circuit

Using a variable value of R_{SET} , as shown in Figure 4, allows for accurate adjustment of the analog output video levels. Use of a fixed 560 Ω R_{SET} resistor yields the analog output levels as quoted in the specification page. These values typically correspond to the RS-343A video waveform values as shown in Figure 3.

D/A Converters

The ADV7121/ADV7122 contains three matched 10-bit D/A converters. The DACs are designed using an advanced, high speed, segmented architecture. The bit currents corresponding to each digital input are routed to either the analog output (bit = "1") or GND (bit = "0") by a sophisticated decoding scheme. As all this circuitry is on one monolithic device, matching between the three DACs is optimized. As well as matching, the use of identical current sources in a monolithic design guarantees monotonicity and low glitch. The onboard operational amplifier stabilizes the full-scale output current against temperature and power supply variations.

Analog Outputs

The ADV7121/ADV7122 has three analog outputs, corresponding to the red, green and blue video signals.

The red, green and blue analog outputs of the ADV7121/ADV7122 are high impedance current sources. Each one of these three RGB current outputs is capable of directly driving a 37.5 Ω load, such as a doubly terminated 75 Ω coaxial cable. Figure 5a shows the required configuration for each of the three RGB outputs connected into a doubly terminated 75 Ω load. This arrangement will develop RS-343A video output voltage levels across a 75 Ω monitor.

A suggested method of driving RS-170 video levels into a 75 Ω monitor is shown in Figure 5b. The output current levels of the DACs remain unchanged, but the source termination resistance, Z_s , on each of the three DACs is increased from 75 Ω to 150 Ω .

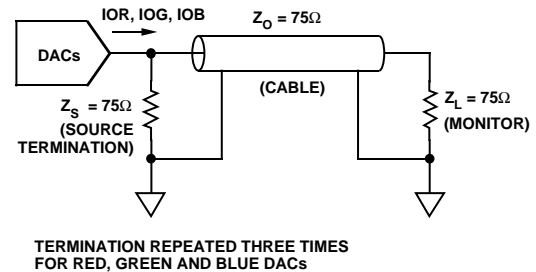

Figure 5a. Analog Output Termination for RS-343A

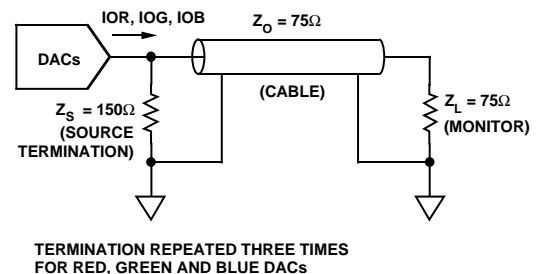

Figure 5b. Analog Output Termination for RS-170

ADV7121/ADV7122

More detailed information regarding load terminations for various output configurations, including RS-343A and RS-170, is available in an Application Note entitled “Video Formats & Required Load Terminations” available from Analog Devices, publication no. E1228-15-1/89.

Figure 3 shows the video waveforms associated with the three RGB outputs driving the doubly terminated 75 Ω load of Figure 5a. As well as the gray scale levels, Black Level to White Level, the diagram also shows the contributions of $\overline{\text{SYNC}}$ and $\overline{\text{BLANK}}$ for the ADV7122. These control inputs add appropriately weighted currents to the analog outputs, producing the specific output level requirements for video applications. Table Ia. details how the $\overline{\text{SYNC}}$ and $\overline{\text{BLANK}}$ inputs modify the output levels.

Gray Scale Operation

The ADV7121/ADV7122 can be used for stand-alone, gray scale (monochrome) or composite video applications (i.e., only one channel used for video information). Any one of the three channels, RED, GREEN or BLUE can be used to input the digital video data. The two unused video data channels should be tied to logical zero. The unused analog outputs should be terminated with the same load as that for the used channel. In other words, if the red channel is used and IOR is terminated with a doubly terminated 75 Ω load (37.5 Ω), IOB and IOG should be terminated with 37.5 Ω resistors. See Figure 6.

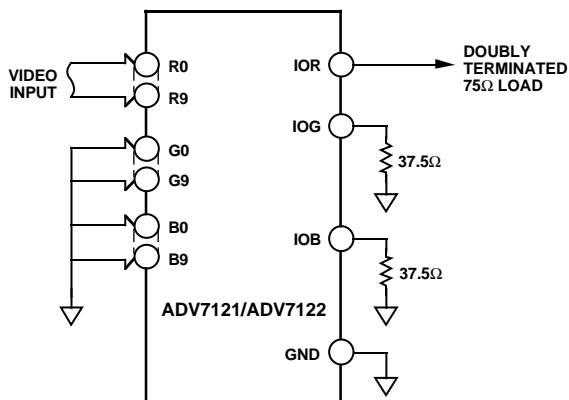

Figure 6. Input and Output Connections for Stand-Alone Gray Scale or Composite Video

Video Output Buffers

The ADV7121/ADV7122 is specified to drive transmission line loads, which is what most monitors are rated as. The analog output configurations to drive such loads are described in the Analog Interface section and illustrated in Figure 5. However, in some applications it may be required to drive long “transmission line” cable lengths. Cable lengths greater than 10 meters can attenuate and distort high frequency analog output pulses. The inclusion of output buffers will compensate for some cable distortion. Buffers with large full power bandwidths and gains between 2 and 4 will be required. These buffers will also need to be able to supply sufficient current over the complete output voltage swing. Analog Devices produces a range of suitable op amps for such applications. These include the AD84x series of monolithic op amps. In very high frequency applications (80 MHz), the AD9617 is recommended. More information on line driver buffering circuits is given in the relevant op amp data sheets.

Use of buffer amplifiers also allows implementation of other video standards besides RS-343A and RS-170. Altering the gain components of the buffer circuit will result in any desired video level.

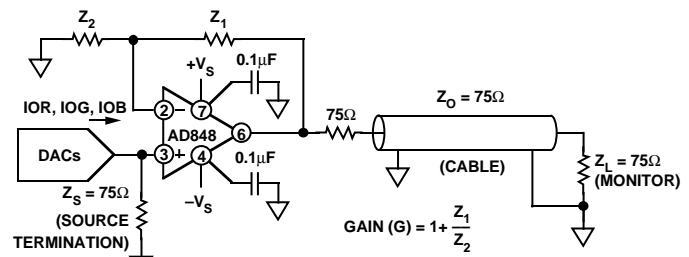

Figure 7. AD848 As an Output Buffer

PC Board Layout Considerations

The ADV7121/ADV7122 is optimally designed for lowest noise performance, both radiated and conducted noise. To complement the excellent noise performance of the ADV7121/ADV7122 it is imperative that great care be given to the PC board layout. Figure 8 shows a recommended connection diagram for the ADV7121/ADV7122.

The layout should be optimized for lowest noise on the ADV7121/ADV7122 power and ground lines. This can be achieved by shielding the digital inputs and providing good decoupling. The lead length between groups of V_{AA} and GND pins should be minimized so as to minimize inductive ringing.

Ground Planes

The ADV7121/ADV7122 and associated analog circuitry, should have a separate ground plane referred to as the analog ground plane. This ground plane should connect to the regular PCB ground plane at a single point through a ferrite bead, as illustrated in Figure 8. This bead should be located as close as possible (within 3 inches) to the ADV7121/ADV7122.

The analog ground plane should encompass all ADV7121/ADV7122 ground pins, voltage reference circuitry, power supply bypass circuitry, the analog output traces and any output amplifiers.

The regular PCB ground plane area should encompass all the digital signal traces, excluding the ground pins, leading up to the ADV7121/ADV7122.

Power Planes

The PC board layout should have two distinct power planes, one for analog circuitry and one for digital circuitry. The analog power plane should encompass the ADV7121/ADV7122 (V_{AA}) and all associated analog circuitry. This power plane should be connected to the regular PCB power plane (V_{CC}) at a single point through a ferrite bead, as illustrated in Figure 8. This bead should be located within three inches of the ADV7121/ADV7122.

The PCB power plane should provide power to all digital logic on the PC board, and the analog power plane should provide power to all ADV7121/ADV7122 power pins, voltage reference circuitry and any output amplifiers.

The PCB power and ground planes should not overlay portions of the analog power plane. Keeping the PCB power and ground planes from overlaying the analog power plane will contribute to a reduction in plane-to-plane noise coupling.

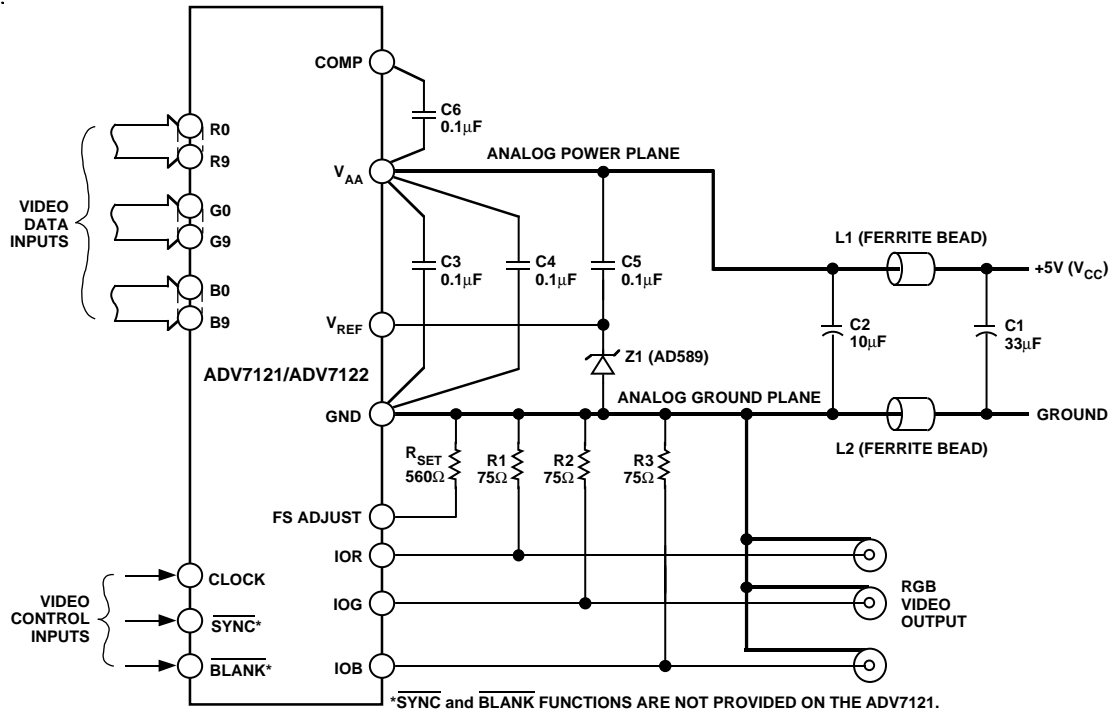

COMPONENT	DESCRIPTION	VENDOR PART NUMBER
C1	33 μ F TANTALUM CAPACITOR	FAIR-RITE 274300111 OR MURATA BL01/02/03
C2	10 μ F TANTALUM	DALE CMF-55C
C3, C4, C5, C6	0.1 μ F CERAMIC CAPACITOR	DALE CMF-55C
L1, L2	FERRITE BEAD	ANALOG DEVICES AD589JH
R1, R2, R3	75 Ω 1% METAL FILM RESISTOR	
R _{SET}	560 Ω 1% METAL FILM RESISTOR	
Z1	1.235V VOLTAGE REFERENCE	

Figure 8. ADV7121/ADV7122 Typical Connection Diagram and Component List

Supply Decoupling

Noise on the analog power plane can be further reduced by the use of multiple decoupling capacitors (see Figure 8).

Optimum performance is achieved by the use of 0.1 μ F ceramic capacitors. Each of the two groups of V_{AA} should be individually decoupled to ground. This should be done by placing the capacitors as close as possible to the device with the capacitor leads as short as possible, thus minimizing lead inductance.

It is important to note that while the ADV7121/ADV7122 contains circuitry to reject power supply noise, this rejection decreases with frequency. If a high frequency switching power supply is used, the designer should pay close attention to reducing power supply noise. A dc power supply filter (Murata BNX002) will provide EMI suppression between the switching power supply and the main PCB. Alternatively, consideration could be given to using a three terminal voltage regulator.

Digital Signal Interconnect

The digital signal lines to the ADV7121/ADV7122 should be isolated as much as possible from the analog outputs and other analog circuitry. Digital signal lines should not overlay the analog power plane.

Due to the high clock rates used, long clock lines to the ADV7121/ADV7122 should be avoided so as to minimize noise pickup.

Any active pull-up termination resistors for the digital inputs should be connected to the regular PCB power plane (V_{CC}), and not the analog power plane.

Analog Signal Interconnect

The ADV7121/ADV7122 should be located as close as possible to the output connectors thus minimizing noise pickup and reflections due to impedance mismatch.

The video output signals should overlay the ground plane, and not the analog power plane, thereby maximizing the high frequency power supply rejection.

For optimum performance, the analog outputs should each have a source termination resistance to ground of 75 Ω (doubly terminated 75 Ω configuration). This termination resistance should be as close as possible to the ADV7121/ADV7122 so as to minimize reflections.

Additional information on PCB design is available in an application note entitled "Design and Layout of a Video Graphics System for Reduced EMI." This application note is available from Analog Devices, publication no. E1309-15-10/89.

OUTLINE DIMENSIONS

Dimensions shown in inches and (mm).

44-Terminal Plastic Leaded Chip Carrier
(P-44A)

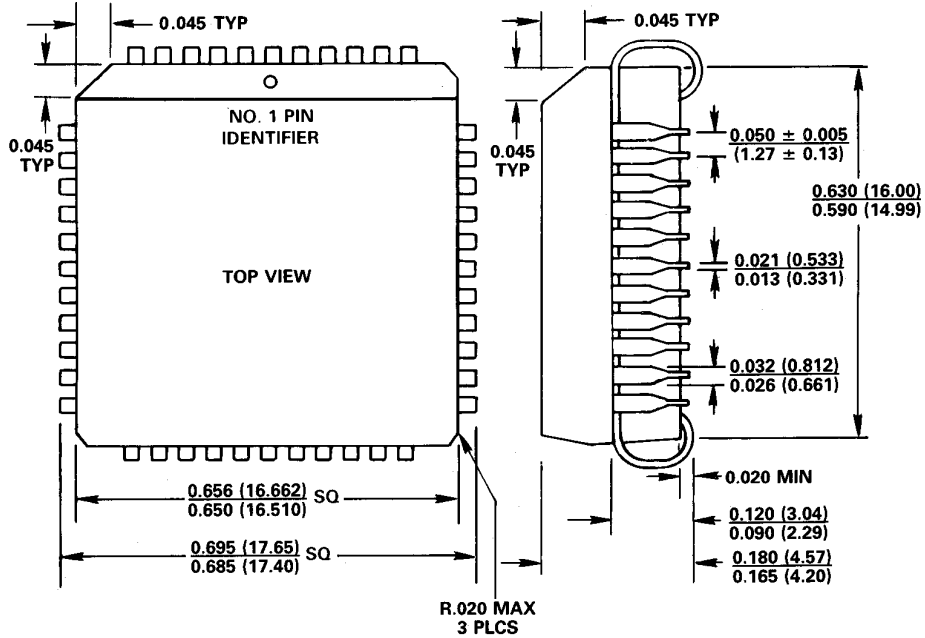

40-Pin Plastic DIP
(N-40A)

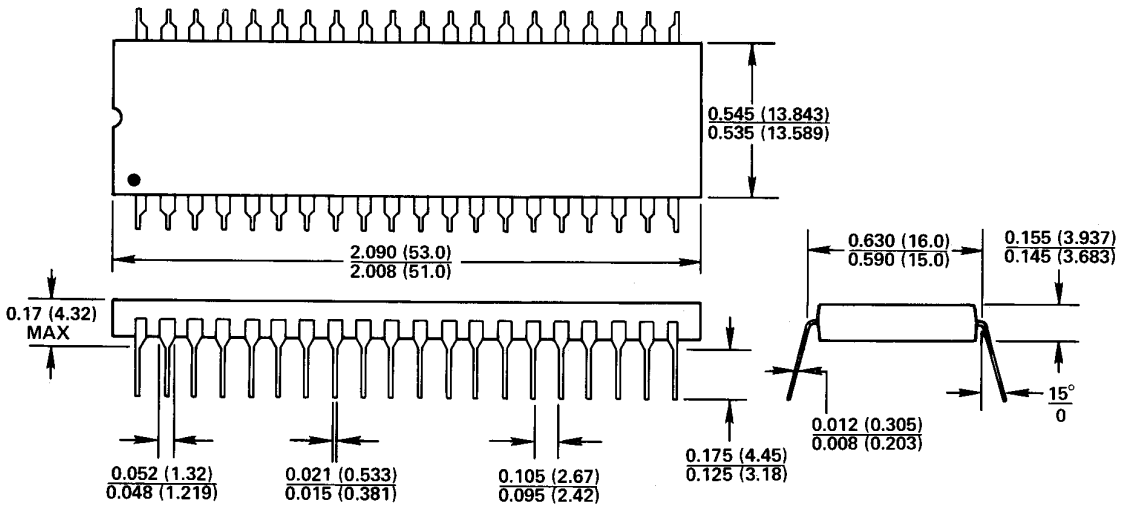

LEAD NO. 1 IDENTIFIED BY DOT, NOTCH OR "1."
LEADS ARE SOLDER PLATED KOVAR OR ALLOY 42.