



AK4438

108dB 768kHz 32bit 8-Channel Audio DAC

1. General Description

The AK4438 is an 8-channel 32-bit DAC which corresponds to digital audio systems. An internal circuit includes newly developed 32-bit Digital Filter achieving short group delay and high quality sound. It corresponds to a 768kHz PCM input at maximum, suitable for play backing high resolution audio sources that are becoming widespread in network audios, USB-DACs and Car Audio Systems. In addition, "OSR-Doubler" technology is newly adopted, making the AK4438 capable of supporting wide range signals and achieving low out-of-band noise while realizing low power consumption. Moreover, the AK4438 has five types of 32-bit digital filters, realizing simple and flexible sound making in wide range of applications.

Application: AV Receivers, CD/SACD Players, Network Audios, USB DACs, USB Headphones, Sound Plate/Bars, Car Audios, Automotive External Amplifiers, Measuring Instruments and Control Systems.

2. Features

1. 8ch 32bit DAC

- 256 x Over sampling
- 32-bit High Quality Sound Short Delay Digital Filter
- Single-ended Output, Smoothing Filter
- THD+N: 91dB
- DR, S/N: 108dB
- Channel Independent Digital Volume Control (0dB~-127dB, 0.5dB Step, Mute)
- Soft Mute
- De-emphasis Filter (supporting 32kHz, 44.1kHz and 48kHz)
- I/F Format: MSB justified, LSB justified, I²S, TDM
- Zero Detection

2. Sampling Frequency

- Normal Speed Mode: 8kHz to 48kHz
- Double Speed Mode: 48kHz to 96kHz
- Quad Speed Mode: 96kHz to 192kHz
- Oct Speed Mode: 384kHz
- Hex Speed Mode: 768kHz

3. Master Clock

- 256fs, 384fs or 512fs, 768fs (Normal Speed Mode: fs=8kHz ~ 48kHz)
- 256fs, 384fs (Double Speed Mode: fs=48kHz ~ 96kHz)
- 128fs, 192fs (Quad Speed Mode: fs=96kHz ~ 192kHz)
- 64fs, 96fs (Oct Speed Mode: fs=384kHz)
- 32fs, 48fs (Hex Speed Mode: fs=768kHz)

4. μ P Interface: 3-wire Serial/ I²C bus (Ver 1.0, 400kHz mode)

5. Power Supply

- Analog Supply: AVDD = 3.0 ~ 3.6V
- In/Output Buffer: TVDD = 1.7 ~ 3.6V
- Integrated LDO for Digital Power Supply

8. Power Consumption: 31mA (fs=48kHz)

9. Operating Temperature: Ta = - 40 ~ 105°C

10. Package: 32-pin QFN(0.5mm pitch)

3. Table of Contents

1. General Description.....	1
2. Features.....	1
3. Table of Contents	2
4. Block Diagram and Functions	3
5. Pin Configurations and Functions	4
■ Pin Configurations.....	4
■ Pin Functions.....	5
■ Handling of Unused Pin	6
6. Absolute Maximum Ratings.....	7
7. Recommended Operation Conditions	7
8. Electrical Characteristics	8
9. Filter Characteristics (fs=48kHz)	9
■ Sharp Roll-Off Filter (SD bit = "0", SLOW bit = "0")	9
■ Slow Roll-Off Filter (SD bit = "0", SLOW bit = "1").....	10
■ Short Delay Sharp Roll-Off Filter (SD bit = "1", SLOW bit = "0")	11
■ Short Delay Slow Roll-Off Filter (SD bit = "1", SLOW bit = "1").....	12
10. DC Characteristics	13
11. Switching Characteristics.....	14
■ Timing Diagram.....	17
12. Functional Descriptions.....	21
■ System Clock	21
■ De-emphasis Filter	24
■ Audio Interface Format.....	25
■ Digital Filter	34
■ Zero Detection.....	34
■ Digital Volume Function	35
■ LR Channel Output Signal Select	36
■ Soft Mute Operation	38
■ Error Detection	39
■ System Reset.....	39
■ Power Down Function	40
■ Power Off and Reset Functions	41
■ Clock Synchronization	45
■ Parallel Mode	47
■ Audio Interface	47
■ Soft Mute	47
■ Serial Control Interface	48
■ Register Map	52
■ Register Definitions	53
13. Recommended External Circuits	58
■ Typical Connection Diagram.....	58
14. Package	61
■ Outline Dimensions.....	61
■ Material & Lead Finish	61
■ Marking.....	62
15. Ordering Guide.....	62
■ Ordering Guide.....	62
16. Revision History	62
IMPORTANT NOTICE.....	63

4. Block Diagram and Functions

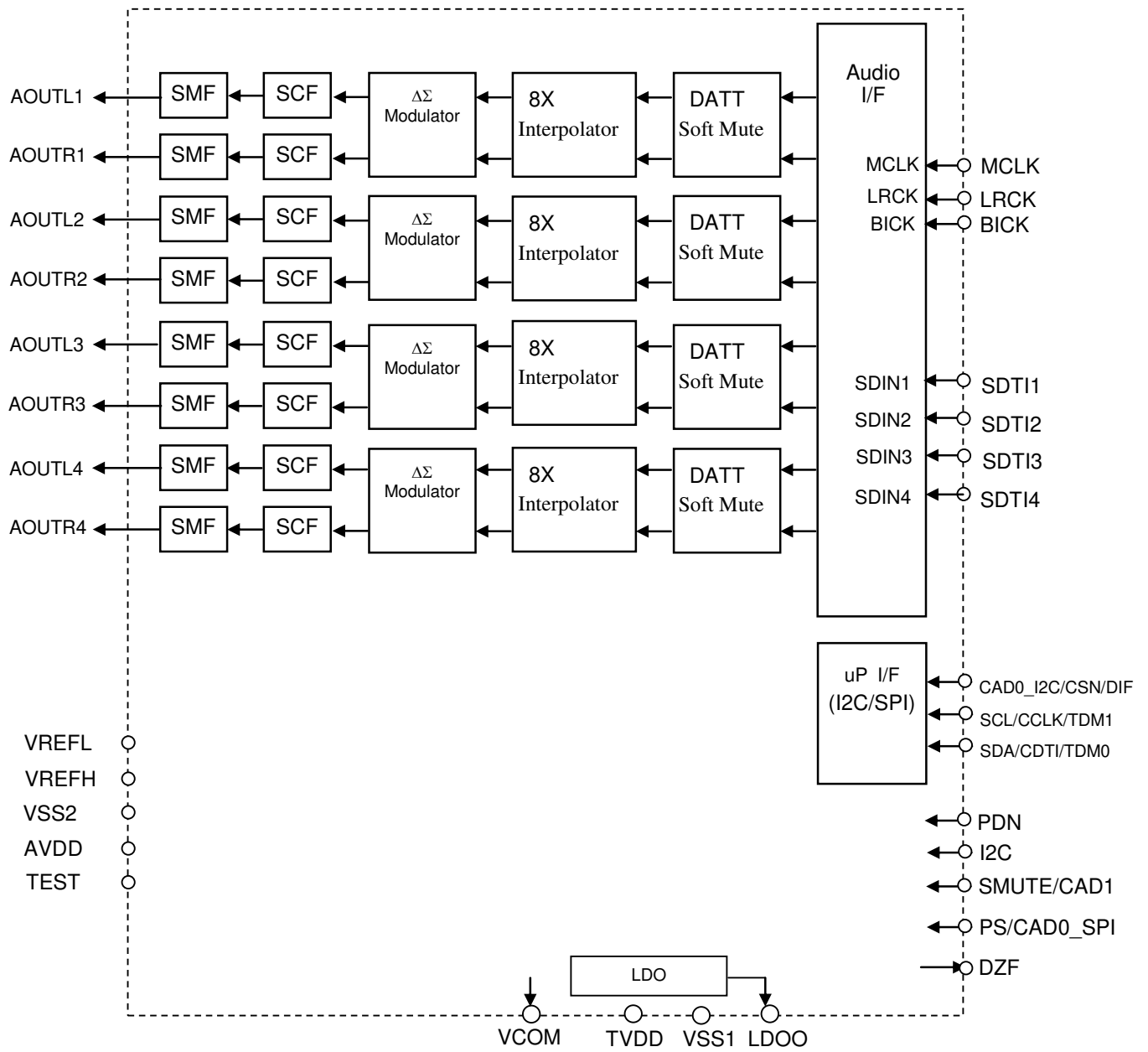

Figure 1. Block Diagram

5. Pin Configurations and Functions

■ Pin Configurations

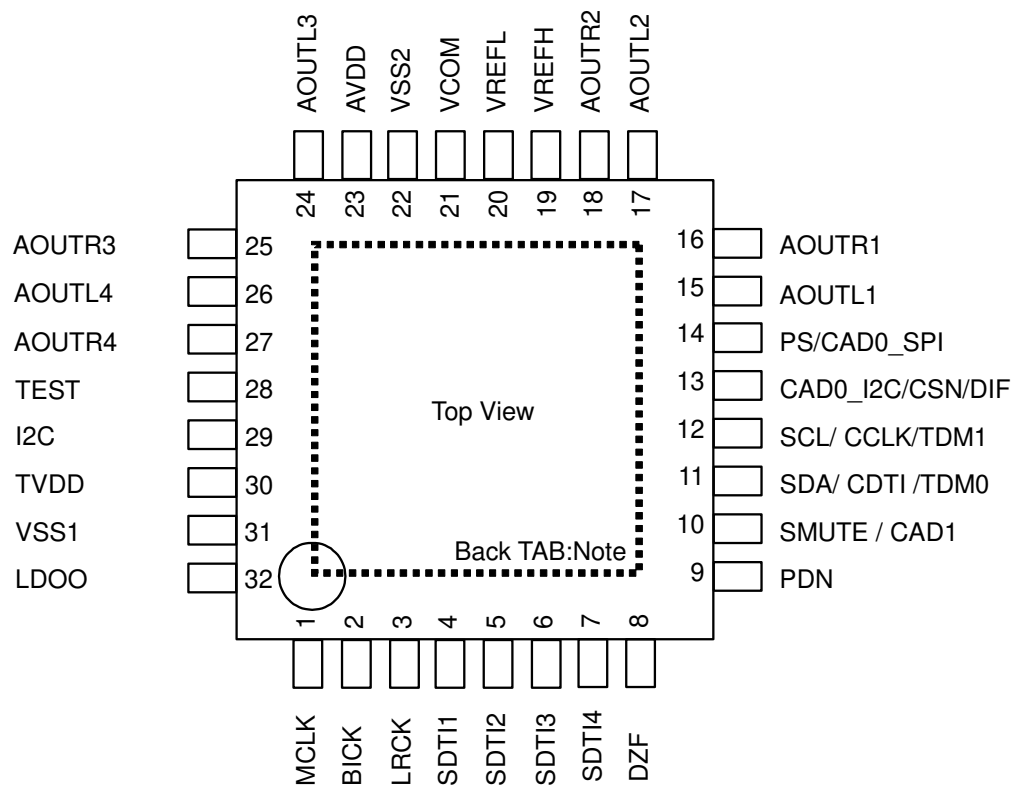

Figure 2. Pin Configurations

Note: The exposed pad on the bottom surface of the package must be open or connected to the analog ground.

■ Pin Functions

No.	Pin Name	I/O	PD state	Function
1	MCLK	I	Hi-z	External Master Clock Input Pin
2	BICK	I	Hi-z	Audio Serial Data Clock Pin
3	LRCK	I	Hi-z	Input Channel Clock Pin
4	SDTI1	I	Hi-z	Audio Serial Data Input
5	SDTI2	I	Hi-z	Audio Serial Data Input
6	SDTI3	I	Hi-z	Audio Serial Data Input
7	SDTI4	I	Hi-z	Audio Serial Data Input
8	DZF	O	50kΩ Pull-down	Zero Input Detect in I2C Bus or 3-wire serial control mode
9	PDN	I	Hi-z	Power-Down & Reset Pin. When "L", the AK4438 is powered-down and the control registers are reset to default state.
10	SMUTE	I	Hi-z	Soft Mute Pin in Parallel control mode. When this pin is changed to "H", soft mute cycle is initiated. When returning "L", the output mute releases.
	CAD1	I		Chip Address 1 Pin in I ² C Bus or 3-wire serial control mode
11	SDA	I/O	Hi-z	Control Data Input Pin in I ² C Bus serial control mode
	CDTI	I		Control Data Input Pin in 3-wire serial control mode
	TDM0	I		TDM Mode select pin in Parallel control mode.
12	SCL	I	Hi-z	Control Data Clock Pin in I ² C Bus serial control mode
	CCLK	I		Control Data Clock Pin in 3-wire serial control mode
	TDM1	I		TDM Mode select pin in Parallel control mode.
13	CAD0_I2C	I	Hi-z	Chip Address 0 Pin in I ² C Bus serial control mode
	CSN	I		Chip Select Pin in 3-wire serial control mode
	DIF	I		Audio Data Format Select in Parallel control mode. "L": 32bit MSB, "H": 32bit I2S
14	PS	I	Hi-z	(I2C pin = "H") Control Mode Select Pin "L": I ² C Bus serial control mode, "H": Parallel control mode.
	CAD0_SPI	I		(I2C pin = "L") Chip Address 0 Pin in 3-wire serial control mode
15	AOUTL1	O	Hi-z	Lch Analog Output Pin
16	AOUTR1	O	Hi-z	Rch Analog Output Pin
17	AOUTL2	O	Hi-z	Lch Analog Output Pin
18	AOUTR2	O	Hi-z	Rch Analog Output Pin
19	VREFH	-	Hi-z	Positive Voltage Reference Input Pin, AVDD
20	VREFL	-	Hi-z	Negative Voltage Reference Input Pin, VSS2
21	VCOM	O	500Ω Pull-down	Common Voltage Output Pin, AVDDx1/2 Large external capacitor around 2.2μF is used to reduce power-supply noise.
22	VSS2	-	-	Analog Ground Pin
23	AVDD	-	-	Analog Power Supply Pin, 3.0V~3.6V
24	AOUTL3	O	Hi-z	Lch Analog Output Pin
25	AOUTR3	O	Hi-z	Rch Analog Output Pin
26	AOUTL4	O	Hi-z	Lch Analog Output Pin
27	AOUTR4	O	Hi-z	Rch Analog Output Pin
28	TEST	-	25kΩ Pull-down	This pin must be connected to VSS1.
29	I2C	I	Hi-z	Control Mode Select Pin "L": 3-wire serial control mode "H": I ² C Bus serial control mode or Parallel control mode.
30	TVDD	-	-	Digital Power Supply Pin, 1.7V~3.6V
31	VSS1	-	-	Digital Ground Pin
32	LDOO	O	580Ω Pull-down	LDO Output Pin. This pin must be connected to ground with 2.2uF ±50%.

Note 1. All digital input pins must not be allowed to float.

■ Handling of Unused Pin

Unused I/O pins must be connected appropriately.

Classification	Pin Name	Setting
Analog	AOUTL1-4, AOUTR1-4	Open
Digital	DZF	Open
	SDTI1-4	Connect to VSS1

6. Absolute Maximum Ratings

(VSS1=VSS2=0V; [Note 2](#))

Parameter	Symbol	Min.	Max.	Unit
Power Supplies				
Analog	AVDD	-0.3	4.3	V
Digital	TVDD	-0.3	4.3	V
Difference (VSS1 ~ 2)	Δ GND	-0.3	0.3	V
Input Current (any pins except for supplies)	IIN	-	\pm 10	mA
Digital Input Voltage	VIND	-0.3	TVDD+0.3	V
Ambient Temperature (power applied)	Ta	-40	105	°C
Storage Temperature	Tstg	-65	150	°C

Note 2. All voltages with respect to ground. VSS1 and VSS2 must be connected to the same analog ground plane.

Note 3. The maximum Digital input voltage is smaller value between (LVDD+0.3)V and 4.3V.

WARNING: Operation at or beyond these limits may result in permanent damage to the device.
Normal operation is not guaranteed at these extremes.

7. Recommended Operation Conditions

(VSS1=VSS2=0V; [Note 2](#))

Parameter		Symbol	Min.	Typ.	Max.	Unit
Power Supplies	Analog	AVDD	3.0	3.3	3.6	V
	Digital	TVDD	1.7	3.3	3.6	V
Voltage Reference (Note 5)	“H” voltage reference	VREFH	AVDD-0.5	-	AVDD	V
	“L” voltage reference	VREFL	-	VSS2	-	V

Note 4. The power up sequence between AVDD and TVDD is not critical.

Note 5. The VREFL pin must be connected to VSS2.

Note 6. Do not turn off the power supply of the AK4438 with the power supply of the peripheral device turned on. When using the I²C interface, pull-up resistors of SDA and SCL pins should be connected to TVDD or less voltage.

* AKM assumes no responsibility for the usage beyond the conditions in this data sheet.

8. Electrical Characteristics

(Ta=25°C; AVDD =TVDD=3.3V; VSS1=VSS2 =0V; VREFH=AVDD; fs=48kHz; BICK=64fs; Signal Frequency=1kHz; 32bit Data; Measurement Frequency=20Hz~20kHz at 48kHz, 20Hz~40kHz at fs=96kHz, 20Hz~40kHz at fs=192kHz, unless otherwise specified.)

Parameter		Min.	Typ.	Max.	Unit
DAC Analog Output Characteristics					
Resolution				32	bit
Output Voltage	(Note 7)	2.55	2.83	3.11	Vpp
S/(N+D) (0dBFS)	fs=48kHz	80	91		dB
	fs=96kHz	-	89		dB
	fs=192kHz	-	89		dB
Dynamic Range (-60dBFS)	fs=48kHz (A-weighted)	104	108		dB
	fs=96kHz	-	101		dB
	fs=192kHz	-	101		dB
S/N	fs=48kHz (A-weighted)	104	108		dB
	fs=96kHz	-	101		dB
	fs=192kHz	-	101		dB
Interchannel Isolation		90	110		dB
Interchannel Gain Mismatch			0	0.7	dB
Load Resistance	(Note 8)	10			kΩ
Load Capacitance				30	pF
Power Supply Rejection	(Note 9)	-	50	-	dB

Note 7. Full-scale output voltage. The output voltage is always proportional to AVDD (AVDD x 0.86).

Note 8. AC Load

Note 9. This is a value when applying a 1kHz 50mVpp sine wave to AVDD.

Parameter		Min.	Typ.	Max.	Unit
Power Supplies					
Power Supply Current					
Normal Operation (PDN pin = "H")					
AVDD	fs=48kHz, 96kHz, 192kHz		27	36	mA
TVDD	fs=48kHz		3.4	4.5	mA
TVDD	fs=96kHz		4.9	6.4	mA
TVDD	fs=192kHz		8.0	10.4	mA
Power-down mode (PDN pin = "L") (Note 10)					
AVDD+TVDD			10	200	μA

Note 10. Quiescent Current. All digital input pins including clock pins are fixed to VSS.

9. Filter Characteristics (fs=48kHz)

(Ta= -40 ~ +105°C; AVDD =3.0~ 3.6V, TVDD=1.7~ 3.6V; DEM=OFF)

■ Sharp Roll-Off Filter (SD bit = "0", SLOW bit = "0")

fs=44.1kHz

Parameter	Symbol	Min.	Typ.	Max.	Unit	
Digital Filter						
Passband (Note 11)	±0.05dB	PB	0		20.0	kHz
	-3.0dB	PB		21.5		kHz
Passband Ripple (Note 12)		PR	-0.0032		0.0032	dB
Stopband (Note 11)		SB	24.1			kHz
Stopband Attenuation (Note 14)		SA	80			dB
Group Delay (Note 13)		GD	-	26.8	-	1/fs
Digital Filter + SCF + SMF (Note 14)						
Frequency Response : 0 ~ 20.0kHz			-0.26		0.1	dB

fs=96kHz

Parameter	Symbol	Min.	Typ.	Max.	Unit	
Digital Filter						
Passband (Note 11)	±0.05dB	PB	0		43.5	kHz
	-3.0dB	PB		46.8		kHz
Passband Ripple (Note 12)		PR	-0.0032		0.0032	dB
Stopband (Note 11)		SB	52.5	0		kHz
Stopband Attenuation (Note 14)		SA	80			dB
Group Delay (Note 13)		GD	-	26.8	-	1/fs
Digital Filter + SCF + SMF (Note 14)						
Frequency Response : 0 ~ 20.0kHz			-0.53		0.1	dB

fs=192kHz

Parameter	Symbol	Min.	Typ.	Max.	Unit	
Digital Filter						
Passband (Note 11)	±0.05dB	PB	0		87.0	kHz
	-3.0dB	PB		93.6		kHz
Passband Ripple (Note 12)		PR	-0.0032		0.0032	dB
Stopband (Note 11)		SB	105			kHz
Stopband Attenuation (Note 14)		SA	80			dB
Group Delay (Note 13)		GD	-	26.8	-	1/fs
Digital Filter + SCF + SMF (Note 14)						
Frequency Response : 0 ~ 20.0kHz			-1.9		0.1	dB

Note 11. The pass band and stop band frequencies scale with fs. For example, PB=0.4535×fs, SB=0.546×fs.

Note 12. It is the pass band gain amplitude of the double over sampling filter at the first step of the Interpolator.

Note 13. The calculating delay time which occurred by digital filtering. This time is from setting the 16/20/24/32bit data of both channels to input register to the output of analog signal.

Note 14. The output level is assumed as 0dB when inputting a 1kHz 0dB sine wave.

*Digital filter characteristics are based on simulation results.

■ Slow Roll-Off Filter (SD bit = “0”, SLOW bit = “1”)

fs=44.1kHz

Parameter	Symbol	Min.	Typ.	Max.	Unit
Digital Filter					
Passband (Note 15)	±0.05dB	PB	0	8.1	kHz
	-3.0dB	PB		18.2	kHz
Passband Ripple (Note 12)	PR	-0.043		0.0032	dB
Stopband (Note 15)	SB	39.2			kHz
Stopband Attenuation (Note 14)	SA	73			dB
Group Delay (Note 13)	GD	-	6.3	-	1/fs
Digital Filter + SCF + SMF (Note 14)					
Frequency Response : 0 ~ 20.0kHz		-5.06		0.1	dB

fs=96kHz

Parameter	Symbol	Min.	Typ.	Max.	Unit
Digital Filter					
Passband (Note 15)	±0.05dB	PB	0	17.7	kHz
	-3.0dB	PB		39.5	kHz
Passband Ripple (Note 12)	PR	-0.043		0.043	dB
Stopband (Note 15)	SB	85.3			kHz
Stopband Attenuation (Note 14)	SA	73			dB
Group Delay (Note 13)	GD	-	6.3	-	1/fs
Digital Filter + SCF + SMF (Note 14)					
Frequency Response : 0 ~ 20.0kHz		-5.23		0.1	dB

fs=192kHz

Parameter	Symbol	Min.	Typ.	Max.	Unit
Digital Filter					
Passband (Note 15)	±0.05dB	PB	0	35.5	kHz
	-3.0dB	PB		79.0	kHz
Passband Ripple (Note 12)	PR	-0.043		0.043	dB
Stopband (Note 15)	SB	171			kHz
Stopband Attenuation (Note 14)	SA	73			dB
Group Delay (Note 13)	GD	-	6.3	-	1/fs
Digital Filter + SCF + SMF (Note 14)					
Frequency Response : 0 ~ 20.0kHz		-5.90		0.1	dB

Note 15. The pass band and stop band frequencies scale with fs. For example, PB=0.185×fs,
SB=0.888×fs.

■ Short Delay Sharp Roll-Off Filter (SD bit = “1”, SLOW bit = “0”)

fs=44.1kHz

Parameter		Symbol	Min.	Typ.	Max.	Unit
Digital Filter						
Passband (Note 11)	±0.05dB	PB	0		20.0	kHz
	-3.0dB	PB		21.5		kHz
Passband Ripple (Note 12)		PR	-0.0031		0.0031	dB
Stopband (Note 11)		SB	24.1			kHz
Stopband Attenuation (Note 14)		SA	80			dB
Group Delay (Note 13)		GD	-	5.8	-	1/fs
Digital Filter + SCF + SMF (Note 14)						
Frequency Response : 0 ~ 20.0kHz			-0.26		0.1	dB

fs=96kHz

Parameter		Symbol	Min.	Typ.	Max.	Unit
Digital Filter						
Passband (Note 11)	±0.05dB	PB	0		43.5	kHz
	-3.0dB	PB		46.8		kHz
Passband Ripple (Note 12)		PR	-0.0031		0.0031	dB
Stopband (Note 11)		SB	52.5	0		kHz
Stopband Attenuation (Note 14)		SA	80			dB
Group Delay (Note 13)		GD	-	5.8	-	1/fs
Digital Filter + SCF + SMF (Note 14)						
Frequency Response : 0 ~ 20.0kHz			-0.53		0.1	dB

fs=192kHz

Parameter		Symbol	Min.	Typ.	Max.	Unit
Digital Filter						
Passband (Note 11)	±0.05dB	PB	0		87.0	kHz
	-3.0dB	PB		93.6		kHz
Passband Ripple (Note 12)		PR	-0.0031		0.0031	dB
Stopband (Note 11)		SB	105			kHz
Stopband Attenuation (Note 14)		SA	80			dB
Group Delay (Note 13)		GD	-	5.8	-	1/fs
Digital Filter + SCF + SMF (Note 14)						
Frequency Response : 0 ~ 20.0kHz			-1.9		0.1	dB

■ Short Delay Slow Roll-Off Filter (SD bit = "1", SLOW bit = "1")

fs=44.1kHz

Parameter		Symbol	Min.	Typ.	Max.	Unit
Digital Filter						
Passband (Note 16)	±0.05dB	PB	0		11.1	kHz
	-3.0dB	PB		19.4		kHz
Passband Ripple	(Note 12)	PR	-0.05		0.05	dB
Stopband	(Note 16)	SB	38.1			kHz
Stopband Attenuation	(Note 14)	SA	82			dB
Group Delay	(Note 13)	GD	-	4.8	-	1/fs
Digital Filter + SCF + SMF (Note 14)						
Frequency Response : 0 ~ 20.0kHz			-5.06		0.1	dB

fs=96kHz

Parameter		Symbol	Min.	Typ.	Max.	Unit
Digital Filter						
Passband (Note 16)	±0.05dB	PB	0		24.2	kHz
	-3.0dB	PB		42.1		kHz
Passband Ripple	(Note 12)	PR	-0.05		0.05	dB
Stopband	(Note 16)	SB	83.0			kHz
Stopband Attenuation	(Note 14)	SA	82			dB
Group Delay	(Note 13)	GD	-	4.8	-	1/fs
Digital Filter + SCF + SMF (Note 14)						
Frequency Response : 0 ~ 20.0kHz			-5.23		0.1	dB

fs=192kHz

Parameter		Symbol	Min.	Typ.	Max.	Unit
Digital Filter						
Passband (Note 16)	±0.05dB	PB	0		48.4	kHz
	-3.0dB	PB		84.3		kHz
Passband Ripple	(Note 12)	PR	-0.05		0.05	dB
Stopband	(Note 16)	SB	165.9			kHz
Stopband Attenuation	(Note 14)	SA	82			dB
Group Delay	(Note 13)	GD	-	4.8	-	1/fs
Digital Filter + SCF + SMF (Note 14)						
Frequency Response : 0 ~ 20.0kHz			-5.90		0.1	dB

Note 16. The pass band and stop band frequencies scale with fs. For example, PB=0.252×fs, SB=0.864×fs.

10. DC Characteristics

(Ta= -40 ~ +105°C; AVDD =3.0~ 3.6V, TVDD=1.7~ 3.6V)

Parameter	Symbol	Min.	Typ.	Max.	Unit
TVDD=1.7V ~ 3.0V					
High-Level Input Voltage	VIH1	80%TVDD	-	-	V
Low-Level Input Voltage	VIL1	-	-	20%TVDD	V
TVDD=3.0V ~ 3.6V					
High-Level Input Voltage	VIH2	70%TVDD	-	-	V
Low-Level Input Voltage	VIL2	-	-	30%TVDD	V
High-Level Output Voltage (DZF pins: Iout= -100μA)	VOH	TVDD-0.5	-	-	V
Low-Level Output Voltage (DZF pin : Iout= 100μA)	VOL1	-	-	0.5	V
(SDA pin, 2.0V ≤ TVDD ≤ 3.6V: Iout= 3mA)	VOL2	-	-	0.4	V
(SDA pin, 1.7V ≤ TVDD ≤ 2.0V: Iout= 3mA)	VOL3	-	-	20%TVDD	V
Input Leakage Current	Iin	-	-	±10	μA

11. Switching Characteristics

(Ta=-40 ~ 105°C; AVDD=3.0 ~ 3.6V, TVDD=1.7 ~ 3.6V; CL=20pF, unless otherwise specified.)

Parameter	Symbol	Min.	Typ.	Max.	Unit
Master Clock Timing					
External Clock					
256fsn:	fCLK	2.048		12.288	MHz
Pulse Width Low	tCLKL	32			ns
Pulse Width High	tCLKH	32			ns
384fsn:	fCLK	3.072		18.432	MHz
Pulse Width Low	tCLKL	22			ns
Pulse Width High	tCLKH	22			ns
512fsn, 256fsd, 128fsq, 64fso, 32fsh:	fCLK	4.096		24.576	MHz
Pulse Width Low	tCLKL	16			ns
Pulse Width High	tCLKH	16			ns
768fsn, 384fsd, 192fsq, 96fso, 48fsh:	fCLK	6.144		36.864	MHz
Pulse Width Low	tCLKL	11			ns
Pulse Width High	tCLKH	11			ns
LRCK Timing (Slave mode)					
Stereo mode (TDM1-0 bits = "00")					
Normal Speed Mode	fsn	8		48	kHz
Double Speed Mode	fsd	48		96	kHz
Quad Speed Mode	fsq	96		192	kHz
Oct speed mode	fso		384		kHz
Hex speed mode	fsh		768		kHz
Duty Cycle	Duty	45		55	%
TDM128 mode (TDM1-0 bits = "01")					
LRCK frequency	fsn	8		48	kHz
	fsd	48		96	kHz
	fsq	96		192	kHz
"H" time	tLRH	1/128fs			ns
"L" time	tLRL	1/128fs			ns
TDM256 mode (TDM1-0 bits = "10")					
LRCK frequency	fsn	8		48	kHz
	fsd	48		96	kHz
"H" time	tLRH	1/256fs			ns
"L" time	tLRL	1/256fs			ns
TDM512 mode (TDM1-0 bits = "11")					
LRCK frequency	fsn	8		48	kHz
"H" time	tLRH	1/512fs			ns
"L" time	tLRL	1/512fs			ns

Parameter	Symbol	Min.	Typ.	Max.	Unit
Audio Interface Timing					
Stereo mode (TDM1-0 bits = "00")					
BICK Period					
Normal Speed Mode	tBCK	1/256fsn			ns
Double Speed Mode	tBCK	1/128fsd			ns
Quad Speed Mode	tBCK	1/64fsq			ns
Oct Speed Mode	tBCK	1/64fso			ns
Hex Speed Mode	tBCK	1/64fsh			ns
BICK Pulse Width Low	tBCKL	9			ns
BICK Pulse Width High	tBCKH	9			ns
LRCK Edge to BICK "↑" (Note 17)	tLRB	5			ns
BICK "↑" to LRCK Edge (Note 17)	tBLR	5			ns
SDTI Hold Time	tSDH	5			
SDTI Setup Time	tSDS	5			
TDM128 mode (TDM1-0 bits = "01")					
BICK Period					
Normal Speed Mode	tBCK	1/128fsn			ns
Double Speed Mode	tBCK	1/128fsd			ns
Quad Speed Mode	tBCK	1/128fsq			ns
BICK Pulse Width Low	tBCKL	16			ns
BICK Pulse Width High	tBCKH	16			ns
LRCK Edge to BICK "↑" (Note 17)	tBLR	5			ns
BICK "↑" to LRCK Edge (Note 17)	tLRB	5			ns
SDTI Hold Time	tSDH	5			ns
SDTI Setup Time	tSDS	5			ns
TDM256 mode (TDM1-0 bits = "10")					
BICK Period					
Normal Speed Mode	tBCK	1/256fsn			ns
Double Speed Mode	tBCK	1/256fsd			ns
BICK Pulse Width Low	tBCKL	16			ns
BICK Pulse Width High	tBCKH	16			ns
LRCK Edge to BICK "↑" (Note 17)	tBLR	5			ns
BICK "↑" to LRCK Edge (Note 17)	tLRB	5			ns
SDTI Hold Time	tSDH	5			ns
SDTI Setup Time	tSDS	5			ns
TDM512 mode (TDM1-0 bits = "11")					
BICK Period					
Normal Speed Mode	tBCK	1/512fsn			ns
BICK Pulse Width Low	tBCKL	16			ns
BICK Pulse Width High	tBCKH	16			ns
LRCK Edge to BICK "↑" (Note 17)	tBLR	5			ns
BICK "↑" to LRCK Edge (Note 17)	tLRB	5			ns
SDTI Hold Time	tSDH	5			ns
SDTI Setup Time	tSDS	5			ns

Note 17. BICK rising edge must not occur at the same time as LRCK edge.

Parameter	Symbol	Min.	Typ.	Max.	Unit
Control Interface Timing (3-wire Serial mode):					
CCLK Period	tCCK	200			ns
CCLK Pulse Width Low	tCCKL	80			ns
Pulse Width High	tCCKH	80			ns
CDTI Setup Time	tCDS	40			ns
CDTI Hold Time	tCDH	40			ns
CSN "H" Time	tCSW	150			ns
CSN "↓" to CCLK "↑"	tCSS	50			ns
CCLK "↑" to CSN "↑"	tCSH	50			ns
Control Interface Timing (I²C Bus mode):					
SCL Clock Frequency	fSCL	-		400	kHz
Bus Free Time Between Transmissions	tBUF	1.3		-	μs
Start Condition Hold Time (prior to first clock pulse)	tHD:STA	0.6		-	μs
Clock Low Time	tLOW	1.3		-	μs
Clock High Time	tHIGH	0.6		-	μs
Setup Time for Repeated Start Condition	tSU:STA	0.6		-	μs
SDA Hold Time from SCL Falling (Note 18)	tHD:DAT	0		-	μs
SDA Setup Time from SCL Rising	tSU:DAT	0.1		-	μs
Rise Time of Both SDA and SCL Lines	tR	-		1.0	μs
Fall Time of Both SDA and SCL Lines	tF	-		0.3	μs
Setup Time for Stop Condition	tSU:STO	0.6		-	μs
Pulse Width of Spike Noise Suppressed by Input Filter	tSP	0		50	ns
Capacitive load on bus	Cb	-		400	pF
Power-down & Reset Timing					
PDN Pulse Width (Note 19)	tAPD	800			ns
PDN Reject Pulse Width	tRPD			50	ns

Note 18. Data must be held for sufficient time to bridge the 300 ns transition time of SCL.

Note 19. The AK4438 can be reset by setting the PDN pin to "L" upon power-up. The PDN pin must held "L" for more than 800ns for a certain reset. The AK4438 is not reset by the "L" pulse less than 50ns.

Note 20. I²C-bus is a trademark of NXP B.V.

■ Timing Diagram

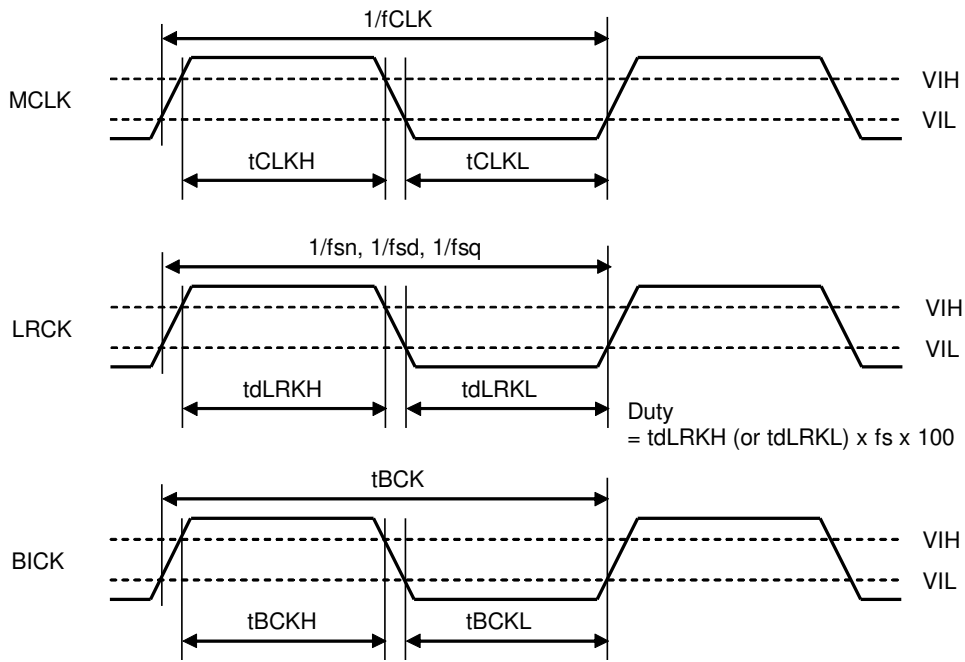

Figure 3. Clock Timing (TDM1-0 bits = "00")

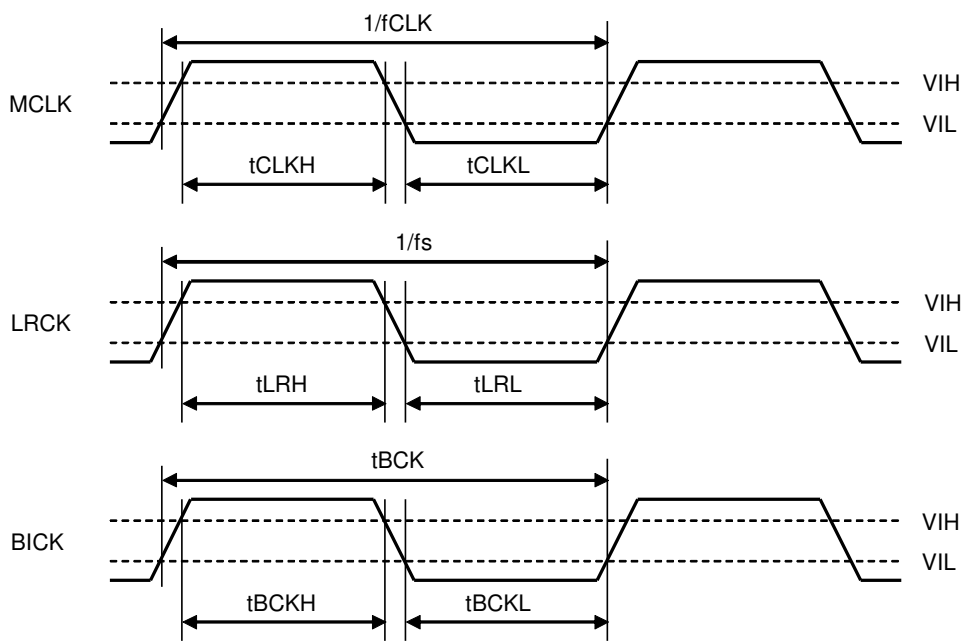

Figure 4. Clock Timing (Except TDM1-0 bits = "00")

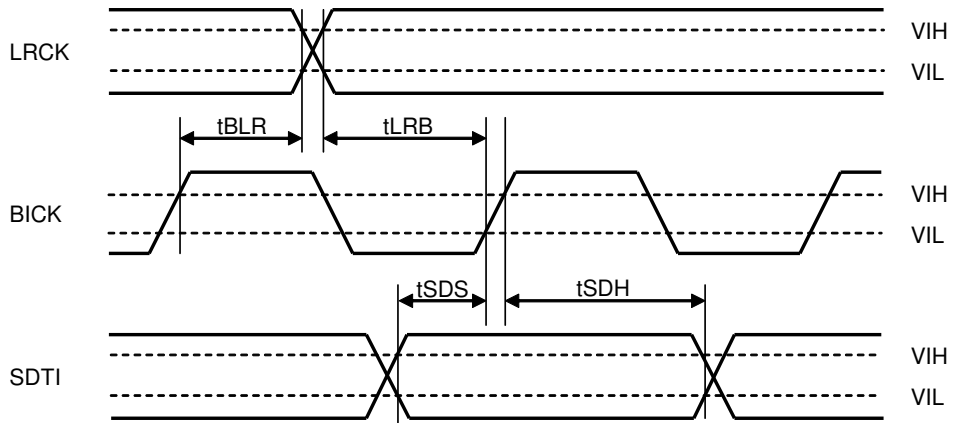

Figure 5. Audio Interface Timing (TDM1-0 bits = "00")

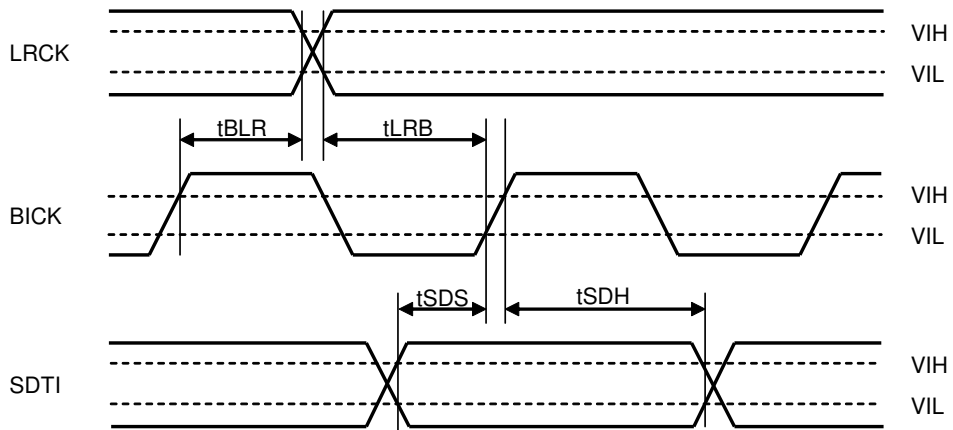

Figure 6. Audio Interface Timing (Except TDM1-0 bits = "00")

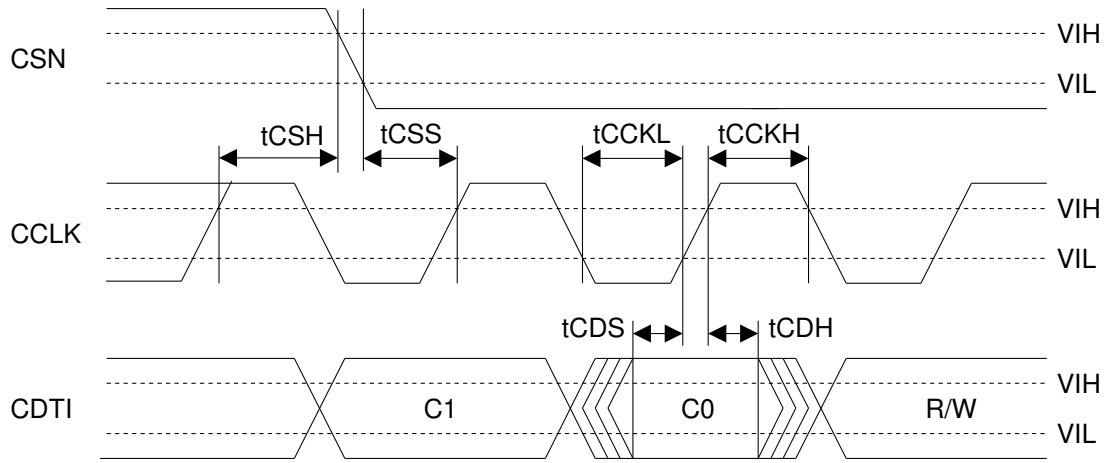

Figure 7. WRITE Command Input Timing (3-wire Serial mode)

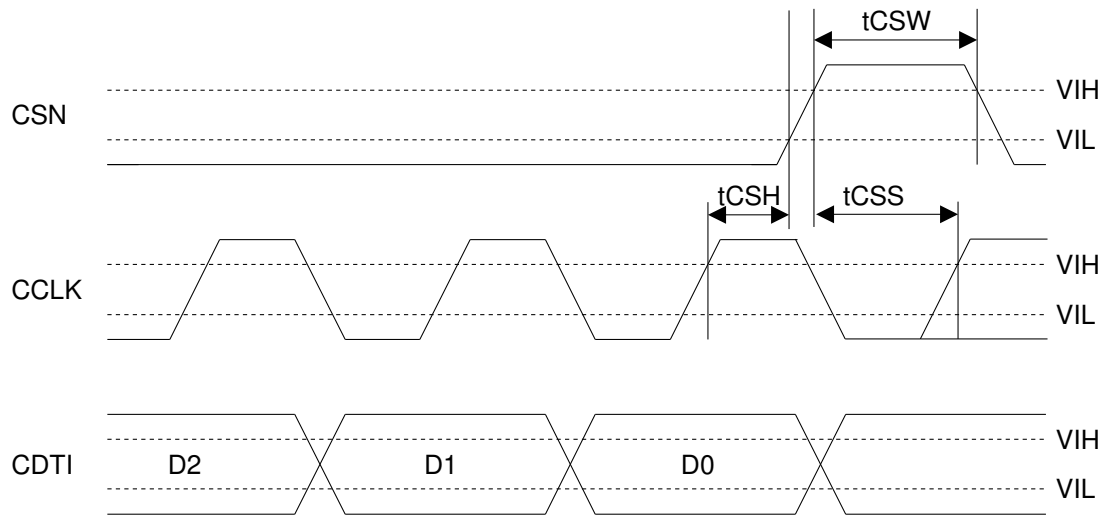

Figure 8. WRITE Data Input Timing (3-wire Serial mode)

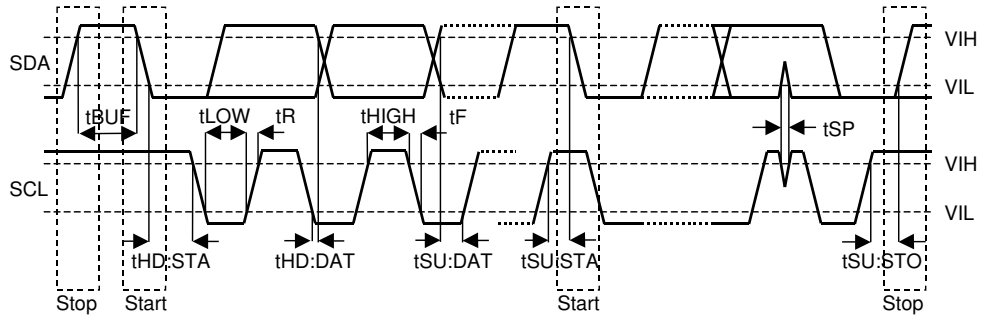

Figure 9. I²C Bus mode Timing

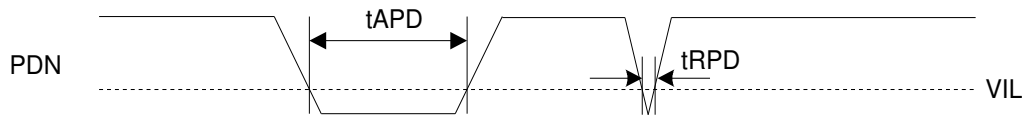

Figure 10. Power-down & Reset Timing

12. Functional Descriptions

■ System Clock

The external clocks which are required to operate the AK4438 are MCLK, LRCK and BICK. MCLK should be synchronized with LRCK and BICK but the phase is not critical. There are two methods to set MCLK frequency. In Manual Setting Mode (ACKS bit= "0": Default), the sampling speed is set by DFS2-0 bit (Table 1). The frequency of MCLK at each sampling speed is set automatically (Table 2, Table 3). In Auto Setting Mode (ACKS bit= "1"), as MCLK frequency is detected automatically (Table 4) and the internal master clock attains the appropriate frequency (Table 5), so it is not necessary to set DFS2-0 bits.

After exiting reset at power-up (PDN pin = "L" → "H"), the AK4438 is in power-down mode until MCLK and LRCK are input. The AK4438 is set to Manual Setting Mode at power-up (PDN pin = "L" → "H"). When changing the clock, the AK4438 must be reset by the PDN pin or RSTN bit.

If the clock is stopped, a click noise occurs when restarting the clock. Mute the digital output externally if the click noise affects system applications.

1. Manual Setting Mode (ACKS bit = "0")

MCLK frequency is detected automatically and the sampling rate is set by DFS2-0 bits (Table 1). The MCLK frequency corresponding to each sampling speed should be provided externally (Table 2, Table 3). The AK4438 is set to Manual Setting Mode at power-up (PDN pin = "L" → "H"). When DFS2-0 bits are changed, the AK4438 should be reset by RSTN bit.

DFS2	DFS1	DFS0	Sampling Speed Mode (fs)	
0	0	0	Normal Speed Mode	8kHz~48kHz
0	0	1	Double Speed Mode	48kHz~96kHz
0	1	0	Quad Speed Mode	96kHz~192kHz
0	1	1	N/A	N/A
1	0	0	Oct Speed Mode	384kHz
1	0	1	Hex Speed Mode	768kHz
1	1	0	N/A	N/A
1	1	1	N/A	N/A

(default)

(N/A: Not Available)

Table 1. Sampling Speed (Manual Setting Mode)

LRCK fs	MCLK(MHz)				Sampling Speed
	32fs	48fs	64fs	96fs	
8.0kHz	N/A	N/A	N/A	N/A	Normal
44.1kHz	N/A	N/A	N/A	N/A	
48.0kHz	N/A	N/A	N/A	N/A	
88.2kHz	N/A	N/A	N/A	N/A	Double
96.0kHz	N/A	N/A	N/A	N/A	
176.4kHz	N/A	N/A	N/A	N/A	Quad
192.0kHz	N/A	N/A	N/A	N/A	
384.0kHz	N/A	N/A	24.576	36.864	Oct
768.0kHz	24.576	36.864	N/A	N/A	Hex

Table 2. System Clock Example (Manual Setting Mode)

LRCK fs	MCLK(MHz)						Sampling Speed
	128fs	192fs	256fs	384fs	512fs	768fs	
8.0kHz	N/A	N/A	2.0480	3.0720	4.0960	6.1440	Normal
44.1kHz	N/A	N/A	11.2896	16.9344	22.5792	33.8688	
48.0kHz	N/A	N/A	12.2880	18.4320	24.5760	36.8640	
88.2kHz	N/A	N/A	22.5792	33.8688	N/A	N/A	Double
96.0kHz	N/A	N/A	24.5760	36.8640	N/A	N/A	
176.4kHz	22.5792	33.8688	N/A	N/A	N/A	N/A	Quad
192.0kHz	24.5760	36.8640	N/A	N/A	N/A	N/A	
384.0kHz	N/A	N/A	N/A	N/A	N/A	N/A	Oct
768.0kHz	N/A	N/A	N/A	N/A	N/A	N/A	Hex

Table 3. System Clock Example (Manual Setting Mode)

2. Auto Setting Mode (ACKS bit = "1")

MCLK frequency and the sampling speed are detected automatically (Table 4) and DFS2-0 bits are ignored. The MCLK frequency corresponding to each sampling speed should be provided externally (Table 5, Table 6).

MCLK		Sampling Speed Mode
512fs/256fs	768fs/384fs	Normal Speed Mode
256fs	384fs	Double Speed Mode
128fs	192fs	Quad Speed Mode
64fs	96fs	Oct Speed Mode
32fs	48fs	Hex Speed Mode

Table 4. Sampling Speed (Auto Setting Mode)

LRCK fs	MCLK(MHz)				Sampling Speed
	32fs	48fs	64fs	96fs	
8.0kHz	N/A	N/A	N/A	N/A	Normal
44.1kHz	N/A	N/A	N/A	N/A	
48.0kHz	N/A	N/A	N/A	N/A	
88.2kHz	N/A	N/A	N/A	N/A	Double
96.0kHz	N/A	N/A	N/A	N/A	
176.4kHz	N/A	N/A	N/A	N/A	Quad
192.0kHz	N/A	N/A	N/A	N/A	
384.0kHz	N/A	N/A	24.576	36.864	Oct
768.0kHz	24.576	36.864	N/A	N/A	Hex

Table 5. System Clock Example (Auto Setting Mode)

LRCK fs	MCLK(MHz)						Sampling Speed
	128fs	192fs	256fs	384fs	512fs	768fs	
8.0kHz	N/A	N/A	2.0480	3.0720	4.0960	6.1440	Normal
44.1kHz	N/A	N/A	11.2896	16.9344	22.5792	33.8688	
48.0kHz	N/A	N/A	12.2880	18.4320	24.5760	36.8640	
88.2kHz	N/A	N/A	22.5792	33.8688	N/A	N/A	Double
96.0kHz	N/A	N/A	24.5760	36.8640	N/A	N/A	
176.4kHz	22.5792	33.8688	N/A	N/A	N/A	N/A	Quad
192.0kHz	24.5760	36.8640	N/A	N/A	N/A	N/A	
384.0kHz	N/A	N/A	N/A	N/A	N/A	N/A	Oct
768.0kHz	N/A	N/A	N/A	N/A	N/A	N/A	Hex

Table 6. System Clock Example (Auto Setting Mode)

MCLK= 256fs/384fs supports sampling rate of 8kHz~96kHz (Table 7). However, when the sampling rate is 8kHz~48kHz, DR and S/N will degrade by approximately 3dB as compared to when MCLK= 512fs/768fs.

ACKS bit	MCLK	DR,S/N
L	256fs/384fs/512fs/768fs	108dB
H	256fs/384fs	105dB
H	512fs/768fs	108dB

Table 7. Relationship of DR, S/N and MCLK frequency (fs = 44.1kHz)

■ De-emphasis Filter

The AK4438 has a digital de-emphasis filter ($t_c=50/15\mu s$) by an IIR filter. The de-emphasis filter only supports Normal Speed Mode. This filter corresponds to three sampling frequencies (32kHz, 44.1kHz, 48kHz). De-emphasis of each DAC can be set individually for DAC1(SDTI1), DAC2(SDTI2), DAC3(SDTI3) and DAC4(SDTI4) by register settings.

Mode	Sampling Speed Mode	DEM11 (DEM41-21)	DEM10 (DEM40-20)	DEM
0	Normal Speed Mode	0	0	44.1kHz
1	Normal Speed Mode	0	1	OFF
2	Normal Speed Mode	1	0	48kHz
3	Normal Speed Mode	1	1	32kHz

(default)

Table 8. De-emphasis Control

■ Audio Interface Format

TDM1-0 bits, DIF2-0 bits, SDS2-0 bits, TDM1-0 pins and DIF pin settings should not be changed during operation.

[1] PCM Mode

Normal Mode (TDM1-0 bit="00")

Eight channels audio data is shifted in via the SDTI1-4 pins using BICK and LRCK inputs. Data is selected by SDS2-0 bits. Eight data formats are supported and selected by the DIF2-0 bits as shown in [Table 9](#). In all formats the serial data is MSB first, 2's compliment format and is latched on the rising edge of BICK. Mode 2 can be used in 16-bit and 20-bit MSB justified and Mode 6 can be used in 16-bit, 20-bit and 24-bit MSB justified formats by zeroing the unused LSBs.

TDM128 Mode (TDM1-0 bit="01")

Eight channels audio data is shifted in via the SDTI1-2 pins using BICK and LRCK inputs. Data is selected by SDS2-0 bits. The data input to the SDTI3-4 pins are ignored. BICK is fixed to 128fs. Six data formats are supported and selected by the DIF2-0 bits as shown in [Table 9](#). In all formats the serial data is MSB first, 2's compliment format and is latched on the rising edge of BICK.

TDM256 Mode (TDM1-0 bit="10")

Sixteen channels audio data is shifted in via the SDTI1-2 pins using BICK and LRCK inputs. Data is selected by SDS2-0 bits. The data input to the SDTI3-4 pins are ignored. BICK is fixed to 256fs. Six data formats are supported and selected by the DIF2-0 bits as shown in [Table 9](#). In all formats the serial data is MSB first, 2's compliment format and is latched on the rising edge of BICK.

TDM512 Mode (TDM1-0 bit="11")

Sixteen channels audio data is shifted in via the SDTI1 pin using BICK and LRCK inputs. Data is selected by SDS2-0 bits. The data input to the SDTI2-4 pins are ignored. BICK is fixed to 512fs. Six data formats are supported and selected by the DIF2-0 bits as shown in [Table 9](#). In all formats the serial data is MSB first, 2's compliment format and is latched on the rising edge of BICK.

Mode		TDM1	TDM0	DIF2	DIF1	DIF0	SDTI Format	LRCK	BICK
Normal (Note 21)	0	0	0	0	0	0	16-bit LSB justified	H/L	≥32fs
	1			0	0	1	20-bit LSB justified	H/L	≥40fs
	2			0	1	0	24-bit MSB justified	H/L	≥48fs
	3			0	1	1	16-bit I ² S compatible	L/H	32fs
				24-bit I ² S compatible	L/H	≥48fs			
	4			1	0	0	24-bit LSB justified	H/L	≥48fs
	5			1	0	1	32-bit LSB justified	H/L	≥64fs
	6			1	1	0	32-bit MSB justified	H/L	≥64fs
7	1	1	1	32-bit I ² S compatible	L/H	≥64fs			
TDM128	-	0	1	0	0	0	N/A	↑	128fs
	-			0	0	1	N/A	↑	128fs
	8			0	1	0	24-bit MSB justified	↑	128fs
	9			0	1	1	24-bit I ² S compatible	↓	128fs
	10			1	0	0	24-bit LSB justified	↑	128fs
	11			1	0	1	32-bit LSB justified	↑	128fs
	12			1	1	0	32-bit MSB justified	↑	128fs
	13			1	1	1	32-bit I ² S compatible	↓	128fs
TDM256	-	1	0	0	0	0	N/A	↑	256fs
	-			0	0	1	N/A	↑	256fs
	14			0	1	0	24-bit MSB justified	↑	256fs
	15			0	1	1	24-bit I ² S compatible	↓	256fs
	16			1	0	0	24-bit LSB justified	↑	256fs
	17			1	0	1	32-bit LSB justified	↑	256fs
	18			1	1	0	32-bit MSB justified	↑	256fs
	19			1	1	1	32-bit I ² S compatible	↓	256fs
TDM512	-	1	1	0	0	0	N/A	↑	512fs
	-			0	0	1	N/A	↑	512fs
	20			0	1	0	24-bit MSB justified	↑	512fs
	21			0	1	1	24-bit I ² S compatible	↓	512fs
	22			1	0	0	24-bit LSB justified	↑	512fs
	23			1	0	1	32-bit LSB justified	↑	512fs
	24			1	1	0	32-bit MSB justified	↑	512fs
	25			1	1	1	32-bit I ² S compatible	↓	512fs

Note 21. BICK that is input to each channel must be longer than the bit length of setting format.
(N/A: Not available)

Table 9. Audio Data Format

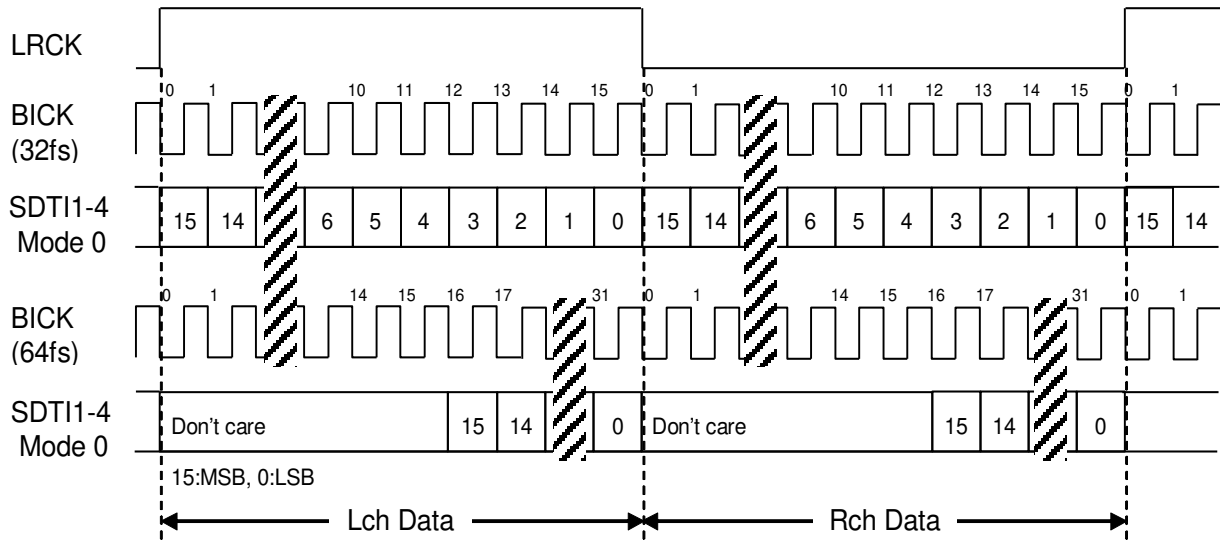

Figure 11. Mode 0 Timing

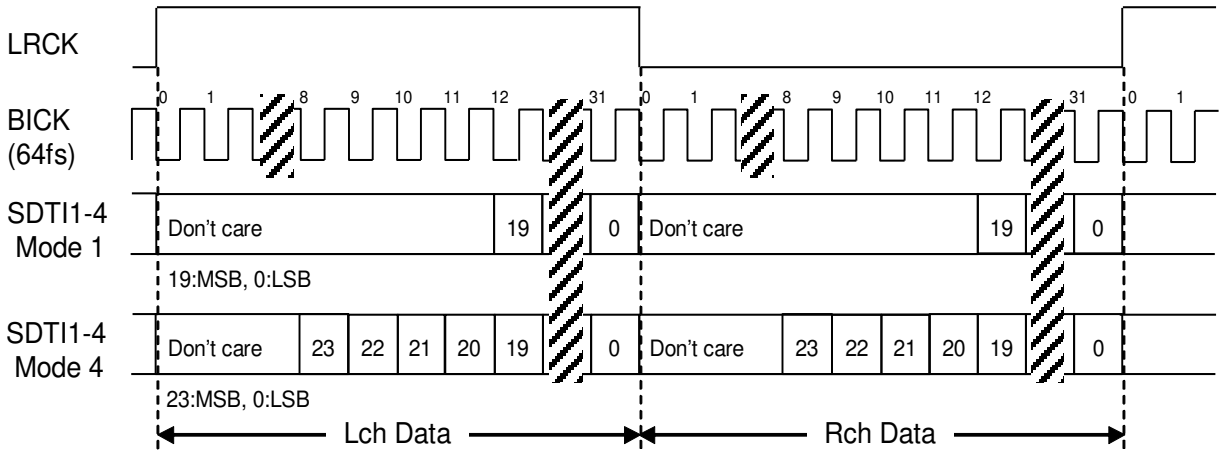

Figure 12. Mode 1/4 Timing

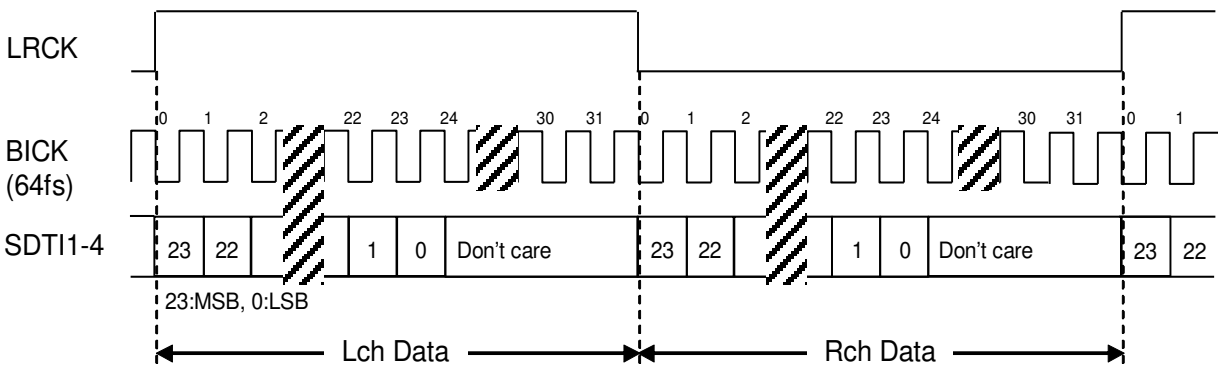

Figure 13. Mode 2 Timing

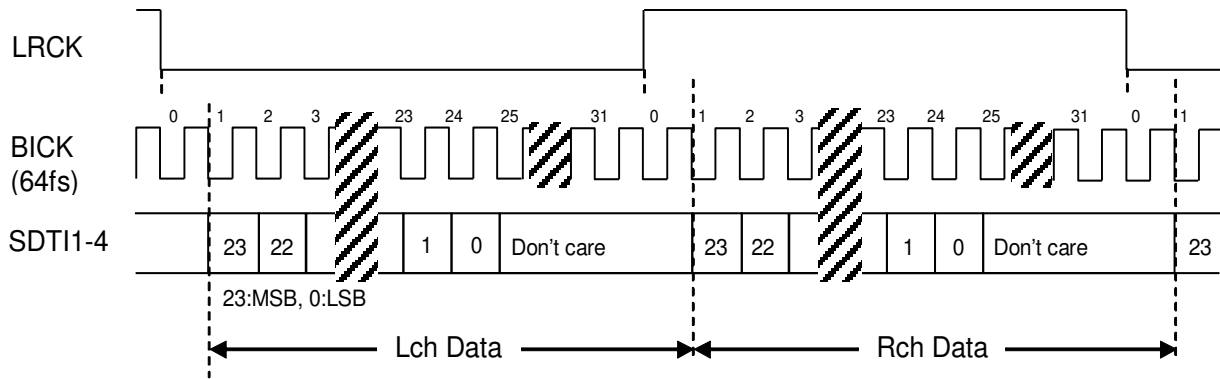

Figure 14. Mode 3 Timing

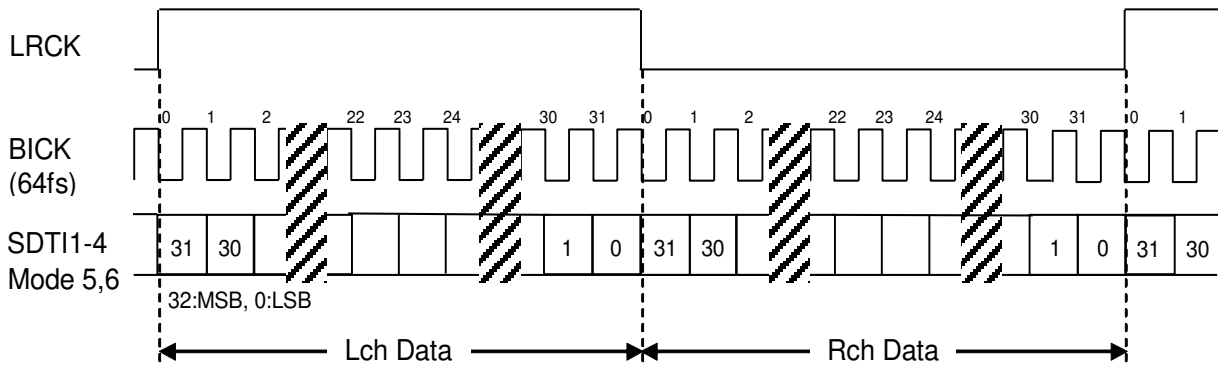

Figure 15. Mode 5/6 Timing

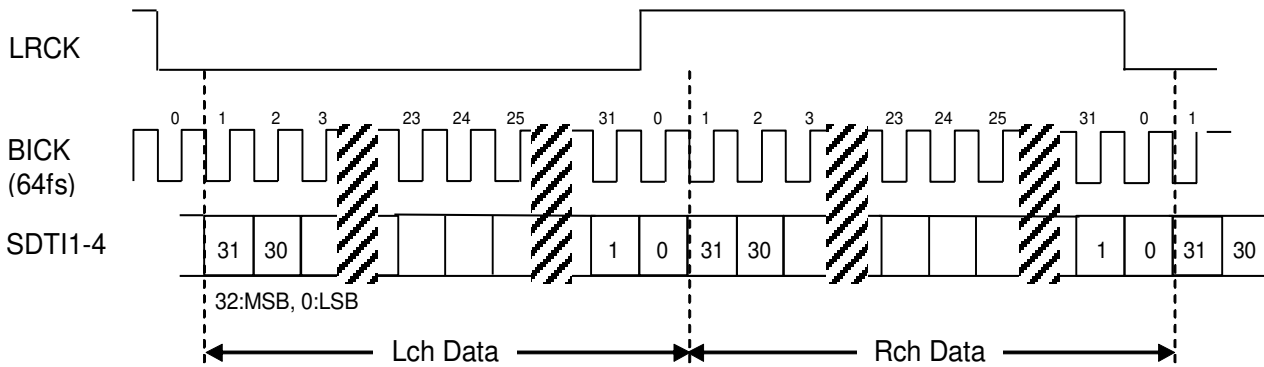

Figure 16. Mode 7 Timing

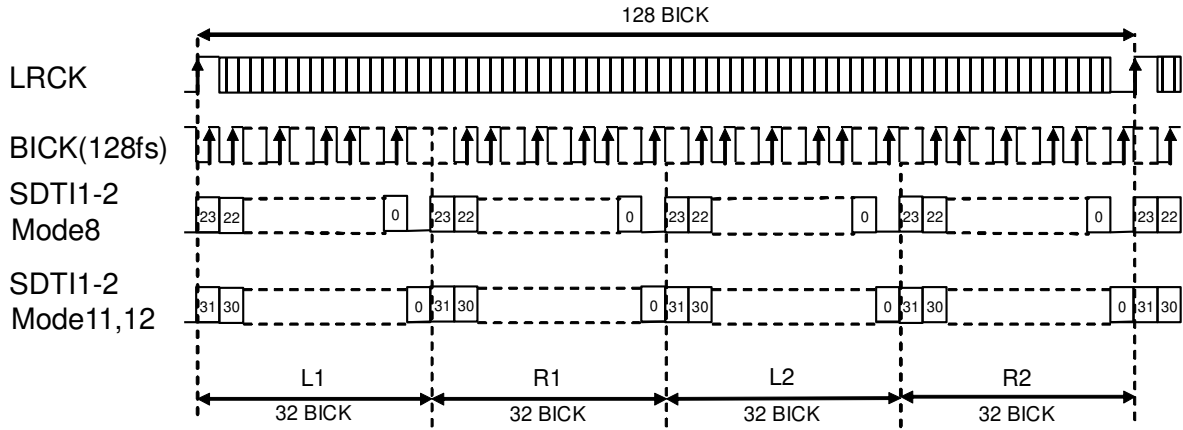

Figure 17. Mode 8/11/12 Timing

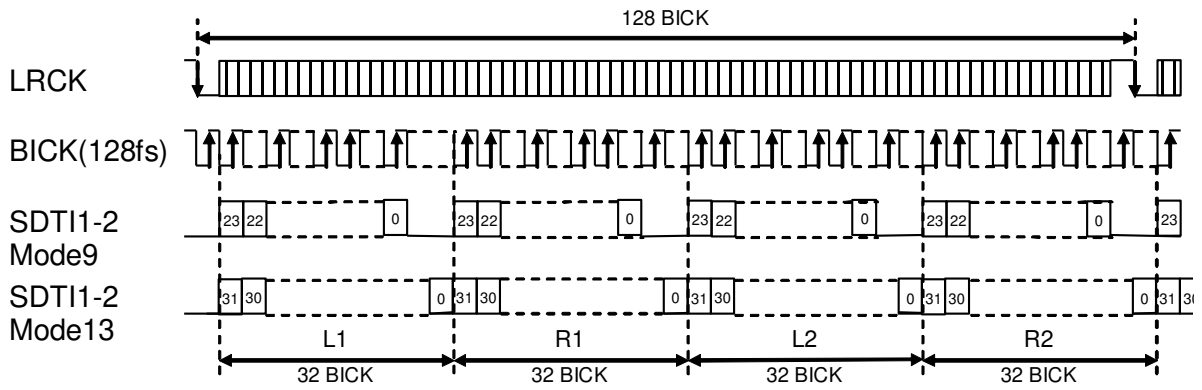

Figure 18. Mode 9/13 Timing

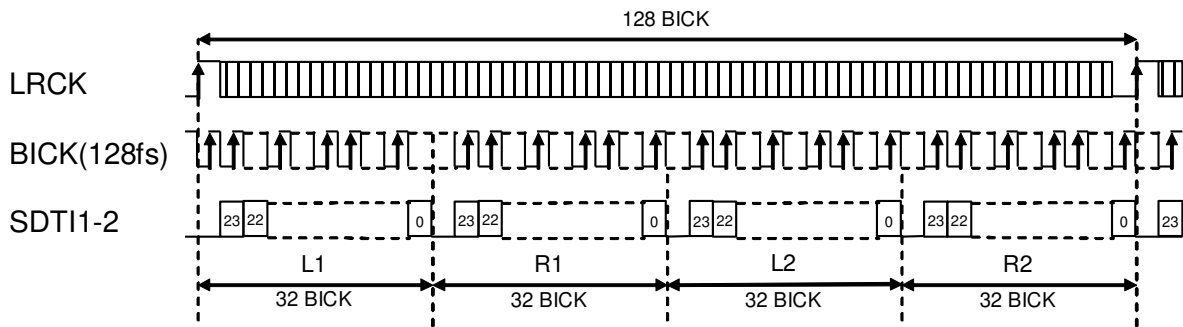

Figure 19. Mode 10 Timing

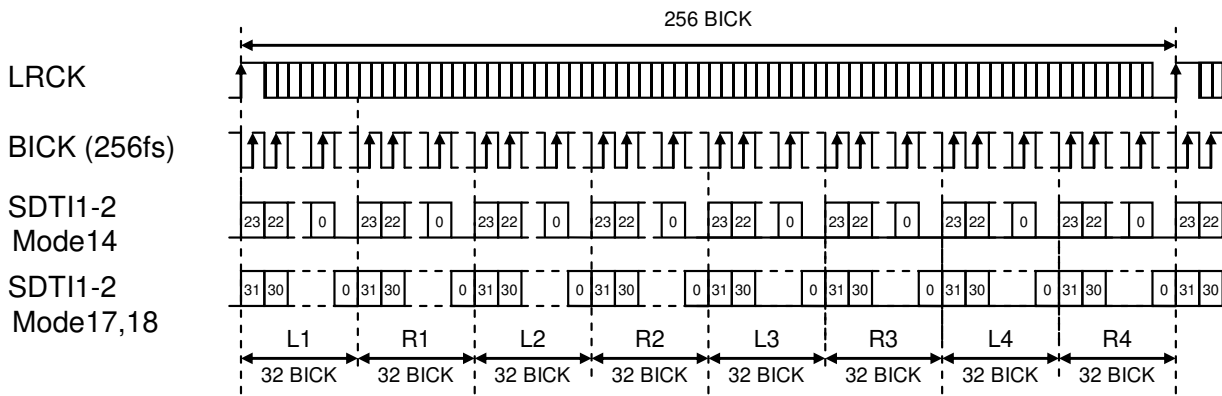

Figure 20. Mode 14/17/18 Timing

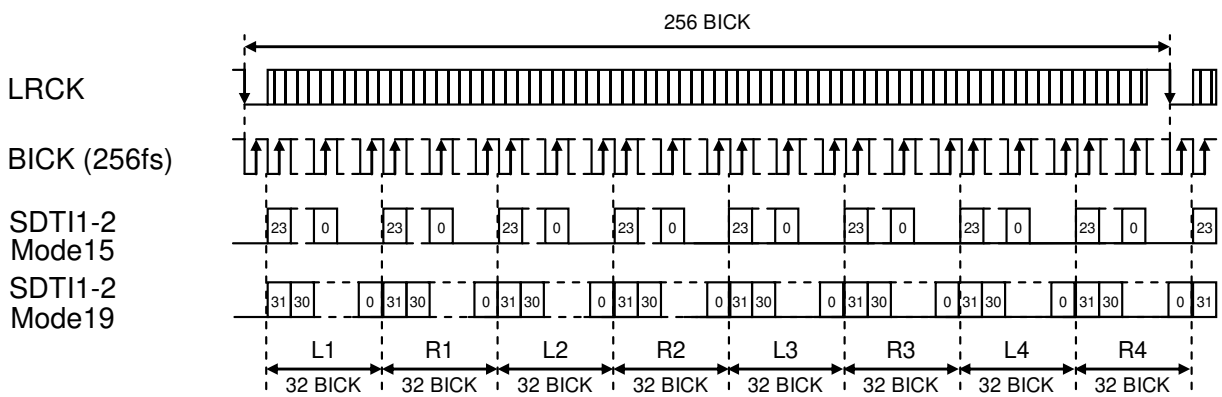

Figure 21. Mode 15/19 Timing

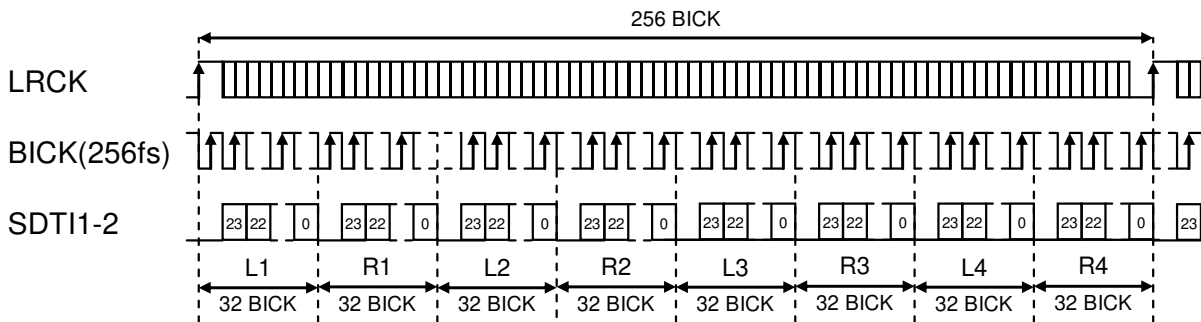

Figure 22. Mode 16 Timing

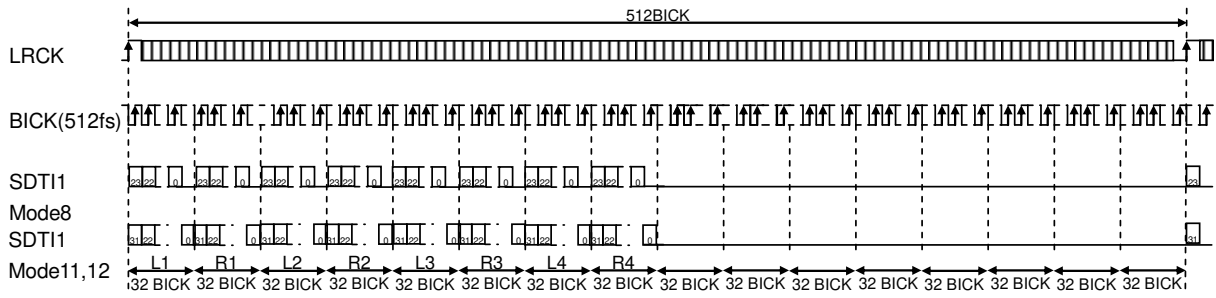

Figure 23. Mode 20/23/24 Timing

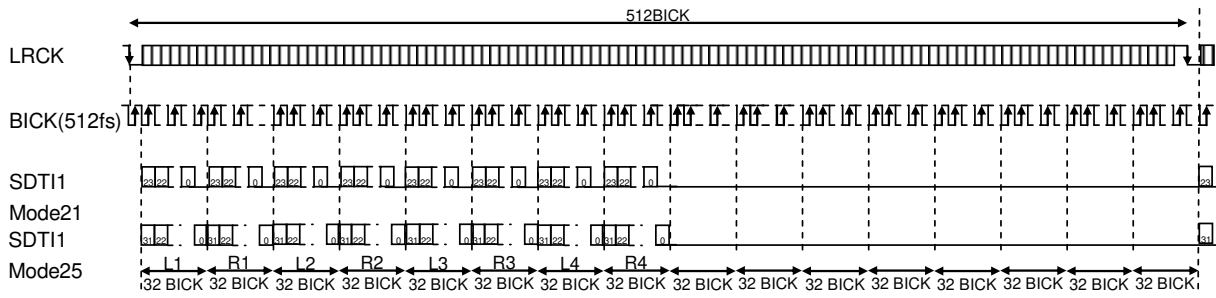

Figure 24. Mode 21/25 Timing

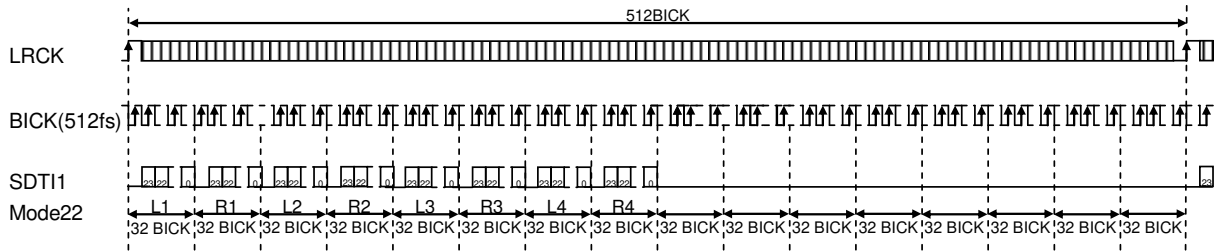

Figure 25. Mode 22 Timing

[2] Data Select

SDS2-0 bits control the playback channel of each DAC.

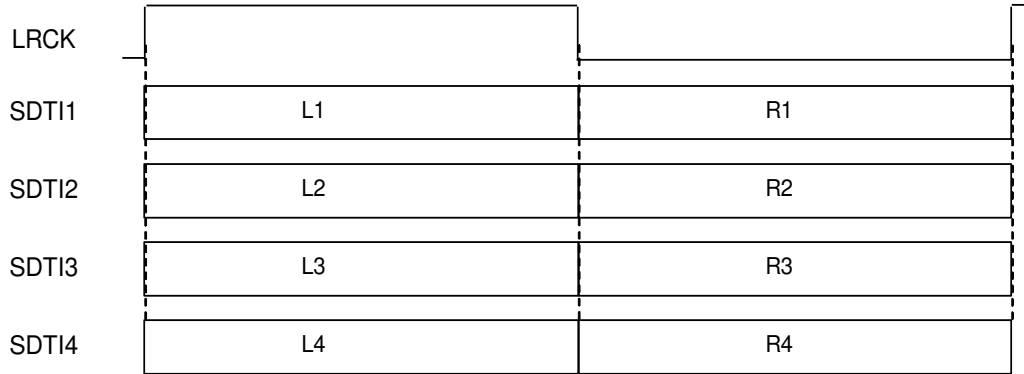

Figure 26. Data Slot in Normal Mode

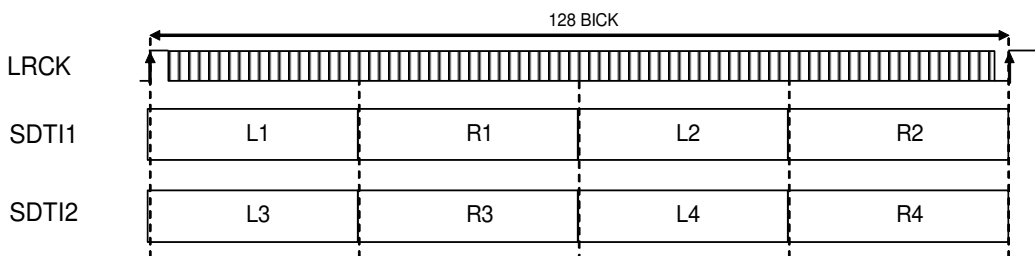

Figure 27. Data Slot in TDM128 Mode

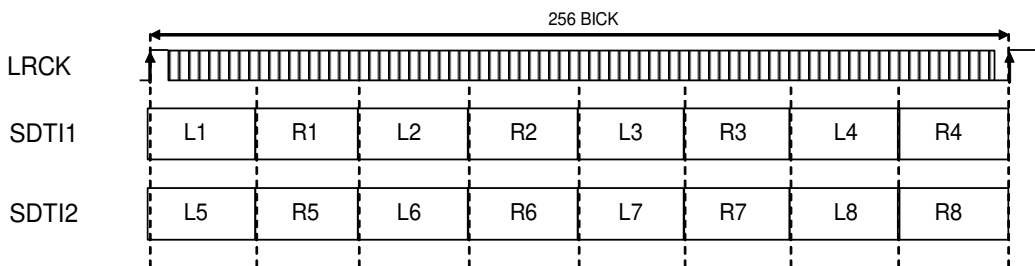

Figure 28. Data Slot in TDM256 Mode

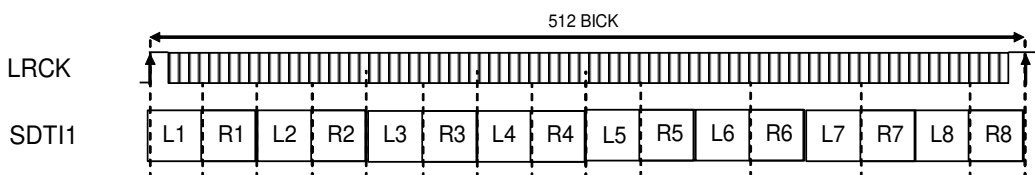

Figure 29. Data Slot in TDM512 Mode

	SDS2	SDS1	SDS0	DAC1		DAC2		DAC3		DAC4	
				Lch	Rch	Lch	Rch	Lch	Rch	Lch	Rch
Normal	*	0	0	L1	R1	L2	R2	L3	R3	L4	R4
	*	0	1	L2	R2	L3	R3	L4	R4	L1	R1
	*	1	0	L3	R3	L4	R4	L1	R1	L2	R2
	*	1	1	L4	R4	L1	R1	L2	R2	L3	R3
TDM128	*	0	0	L1	R1	L2	R2	L3	R3	L4	R4
	*	0	1	L2	R2	L3	R3	L4	R4	L1	R1
	*	1	0	L3	R3	L4	R4	L1	R1	L2	R2
	*	1	1	L4	R4	L1	R1	L2	R2	L3	R3
TDM256	0	0	0	L1	R1	L2	R2	L3	R3	L4	R4
	0	0	1	L2	R2	L3	R3	L4	R4	L5	R5
	0	1	0	L3	R3	L4	R4	L5	R5	L6	R6
	0	1	1	L4	R4	L5	R5	L6	R6	L7	R7
	1	0	0	L5	R5	L6	R6	L7	R7	L8	R8
	1	0	1	L6	R6	L7	R7	L8	R8	L1	R1
	1	1	0	L7	R7	L8	R8	L1	R1	L2	R2
	1	1	1	L8	R8	L1	R1	L2	R2	L3	R3
TDM512	0	0	0	L1	R1	L2	R2	L3	R3	L4	R4
	0	0	1	L2	R2	L3	R3	L4	R4	L5	R5
	0	1	0	L3	R3	L4	R4	L5	R5	L6	R6
	0	1	1	L4	R4	L5	R5	L6	R6	L7	R7
	1	0	0	L5	R5	L6	R6	L7	R7	L8	R8
	1	0	1	L6	R6	L7	R7	L8	R8	L1	R1
	1	1	0	L7	R7	L8	R8	L1	R1	L2	R2
	1	1	1	L8	R8	L1	R1	L2	R2	L3	R3

(*: Do not care)

Table 10. Data Select

■ Digital Filter

Five digital filters are available for playback, providing a choice of different sound colors. These digital filters are selected by SD bit, SLOW bit and SSLOW bit.

SSLOW	SD bit	SLOW bit	Mode
0	0	0	Sharp roll-off filter
0	0	1	Slow roll-off filter
0	1	0	Short delay Sharp roll-off filter
0	1	1	Short delay Slow roll-off filter
1	*	*	Super Slow Roll-off Mode

(default)

Table 11. Digital Filter Setting (*: don't care)

■ Zero Detection

The AK4438 has channel-independent zero detection function. Zero detection channels (AOU_{TL}1-4 and AO_{UTR}1-4 pins) can be selected by 07H/08H registers (L1-4 bits, R1-4 bits). When the input data at each channel is continuously zeros for 8192 LRCK cycles, the DZF pin goes to "H". The DZF pin immediately returns to "L" if the input data of each channel is not zero. If the RSTN bit is "0", the DZF pins of both channels go to "H". The DZF pin of both channels go to "L" after 4 ~ 5/fs when RSTN bit returns to "1". The DZFB bit can invert the polarity of the DZF pin. If all channels are disabled, the DZF pin outputs "Not zero".

DZFB bit	Data	DZF pin
0	Not zero	L
	Zero detect	H
1	Not zero	H
	Zero detect	L

Not zero: One of the zero detection channels set by L1-4 bits and R1-4 bits does not detect zero.

Zero detect: All zero detection channels set by L1-4 bits and R1-4 bits detect zero.

Table 12. DZF Pin Function

■ Digital Volume Function

The AK4438 has a channel-independent digital attenuator (256 levels, 0.5dB steps). Attenuation level of each DAC1-4 can be set by ATT7-0 bits (register 0A-11H), respectively (Table 13).

ATT7-0bits (register 0A-11H)	Attenuation Level	
FFH	+0dB	(default)
FEH	-0.5dB	
FDH	-1.0dB	
:	:	
:	:	
02H	-126.5dB	
01H	-127.0dB	
00H	MUTE ($-\infty$)	

Table 13. Attenuation level of Digital Attenuator

Transition time between set values of ATT7-0 bits can be selected by the ATS1-0 bits (Table 14). The transition between set values is a soft transition in Mode0/1/2 eliminating switching noise in the transition.

Mode	ATS1	ATS0	ATT speed	
0	0	0	4080/fs	(default)
1	0	1	2040/fs	
2	1	0	510/fs	
3	1	1	255/fs	

Table 14. Transition Time of Digital Volume

The transition between set values is a soft transition of 4080 levels in Mode 0. It takes 4080/fs (85ms @fs=48kHz) from FFH to 00H. If the PDN pin goes to "L", ATT7-0 bits are initialized to FFH.

If the digital volume is changed during reset, the volume will be changed to the setting value after releasing the reset. If the volume is changed in 5/fs after releasing a reset, the volume is changed immediately without soft transition.

■ LR Channel Output Signal Select

Input and output signal combination of the AK4438 can be set by MONO1-4 bits and SELLR1-4 bits. The output signal phase of DAC is controlled by INVL1-4 and INVR1-4 bits. These settings are available for any audio format.

MONO1 bit	SELLR1 bit	INVL1 bit	INVR1 bit	L1ch Out	R1ch Out
0	0	0	0	L1ch In	R1ch In
		1	0	L1ch In Invert	R1ch In
		0	1	L1ch In	R1ch In Invert
		1	1	L1ch In Invert	R1ch In Invert
0	1	0	0	R1ch In	L1ch In
		1	0	R1ch In Invert	L1ch In
		0	1	R1ch In	L1ch In Invert
		1	1	R1ch In Invert	L1ch In Invert
1	0	0	0	L1ch In	L1ch In
		1	0	L1ch In Invert	L1ch In
		0	1	L1ch In	L1ch In Invert
		1	1	L1ch In Invert	L1ch In Invert
1	1	0	0	R1ch In	R1ch In
		1	0	R1ch In Invert	R1ch In
		0	1	R1ch In	R1ch In Invert
		1	1	R1ch In Invert	R1ch In Invert

Table 15. Output Select for DAC1

MONO2 bit	SELLR2 bit	INVL2 bit	INVR2 bit	L2ch Out	R2ch Out
0	0	0	0	L2ch In	R2ch In
		1	0	L2ch In Invert	R2ch In
		0	1	L2ch In	R2ch In Invert
		1	1	L2ch In Invert	R2ch In Invert
0	1	0	0	R2ch In	L2ch In
		1	0	R2ch In Invert	L2ch In
		0	1	R2ch In	L2ch In Invert
		1	1	R2ch In Invert	L2ch In Invert
1	0	0	0	L2ch In	L2ch In
		1	0	L2ch In Invert	L2ch In
		0	1	L2ch In	L2ch In Invert
		1	1	L2ch In Invert	L2ch In Invert
1	1	0	0	R2ch In	R2ch In
		1	0	R2ch In Invert	R2ch In
		0	1	R2ch In	R2ch In Invert
		1	1	R2ch In Invert	R2ch In Invert

Table 16. Output Select for DAC2

MONO3 bit	SELLR3 bit	INVL3 bit	INVR3 bit	L3	R3
0	0	0	0	L3ch In	R3ch In
		1	0	L3ch In Invert	R3ch In
		0	1	L3ch In	R3ch In Invert
		1	1	L3ch In Invert	R3ch In Invert
0	1	0	0	R3ch In	L3ch In
		1	0	R3ch In Invert	L3ch In
		0	1	R3ch In	L3ch In Invert
		1	1	R3ch In Invert	L3ch In Invert
1	0	0	0	L3ch In	L3ch In
		1	0	L3ch In Invert	L3ch In
		0	1	L3ch In	L3ch In Invert
		1	1	L3ch In Invert	L3ch In Invert
1	1	0	0	R3ch In	R3ch In
		1	0	R3ch In Invert	R3ch In
		0	1	R3ch In	R3ch In Invert
		1	1	R3ch In Invert	R3ch In Invert

Table 17. Output Select for DAC3

MONO4 bit	SELLR4 bit	INVL4 bit	INVR4 bit	L4	R4
0	0	0	0	L4ch In	R4ch In
		1	0	L4ch In Invert	R4ch In
		0	1	L4ch In	R4ch In Invert
		1	1	L4ch In Invert	R4ch In Invert
0	1	0	0	R4ch In	L4ch In
		1	0	R4ch In Invert	L4ch In
		0	1	R4ch In	L4ch In Invert
		1	1	R4ch In Invert	L4ch In Invert
1	0	0	0	L4ch In	L4ch In
		1	0	L4ch In Invert	L4ch In
		0	1	L4ch In	L4ch In Invert
		1	1	L4ch In Invert	L4ch In Invert
1	1	0	0	R4ch In	R4ch In
		1	0	R4ch In Invert	R4ch In
		0	1	R4ch In	R4ch In Invert
		1	1	R4ch In Invert	R4ch In Invert

Table 18. Output Select for DAC4

■ Soft Mute Operation

The soft mute operation is performed at digital domain. When the SMUTE pin goes to “H” or set SMUTE bit to “1”, the output signal is attenuated by $-\infty$ during $ATT_DATA \times ATT$ transition time from the current ATT level. When the SMUTE pin is returned to “L” or the SMUTE bit is returned to “0”, the mute is cancelled and the output attenuation gradually changes to the ATT level during $ATT_DATA \times ATT$ transition time. If the soft mute is cancelled before attenuating $-\infty$, the attenuation is discontinued and returned to ATT level by the same cycle. The soft mute is effective for changing the signal source without stopping the signal transmission.

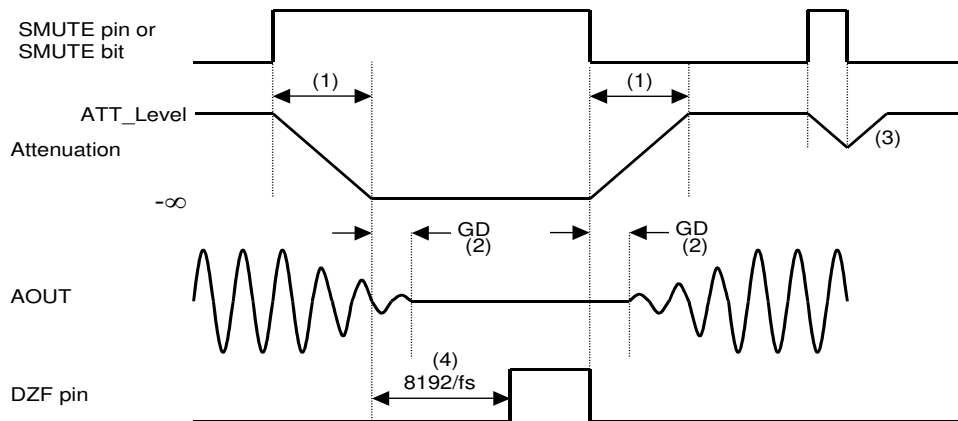

Notes:

- (1) $ATT_DATA \times ATT$ transition time. For example, this time is 4080LRCK cycles at $ATT_DATA=255$ in Normal Speed Mode.
- (2) The analog output corresponding to the digital input has group delay (GD).
- (3) If the soft mute is cancelled before attenuating $-\infty$ after starting the operation, the attenuation is discontinued and returned to ATT level by the same cycle.
- (4) When the input data for a zero detection channel is continuously zeros for 8192 LRCK cycles, the DZF pin goes to “H”. The DZF pin immediately returns to “L” if input data are not zero.

Figure 30. Soft Mute Function and Zero Detection

■ Error Detection

Three types of error can be detected in I²C mode when the LDOE pin = "H". (Table 19). When the error is detected, LDO is powered down and writing into the control registers is prohibited. Once the error is detected the AK4438 does not return to normal operation automatically even if the error condition is removed so restart the AK4438 by the PDN pin. In I²C mode, the AK4438 does not generate acknowledge (ACK) in error status.

No	Error	Error Condition
1	Internal Reference Voltage Error	Internal reference voltage is not powered up.
2	LDO Over Voltage Detection	LDO voltage > 1.5V (typ.)
3	LDO Over Current Detection	LDO current < 51mA (typ.)

Table 19. Error Detection

■ System Reset

The AK4438 should be reset once by bringing the PDN pin = "L" upon power-up. Power-down state of the reference voltage such as LDO and VCOM will be released by PDN pin = "H" and writing into registers is valid in 1ms. The AK4438 is in power-down state until MCLK and LRCK input.

■ Power Down Function

The AK4438 is placed in power-down mode by bringing the PDN pin “L” and the analog outputs become floating (Hi-Z) state. Power-up and power-down timings are shown in [Figure 31](#).

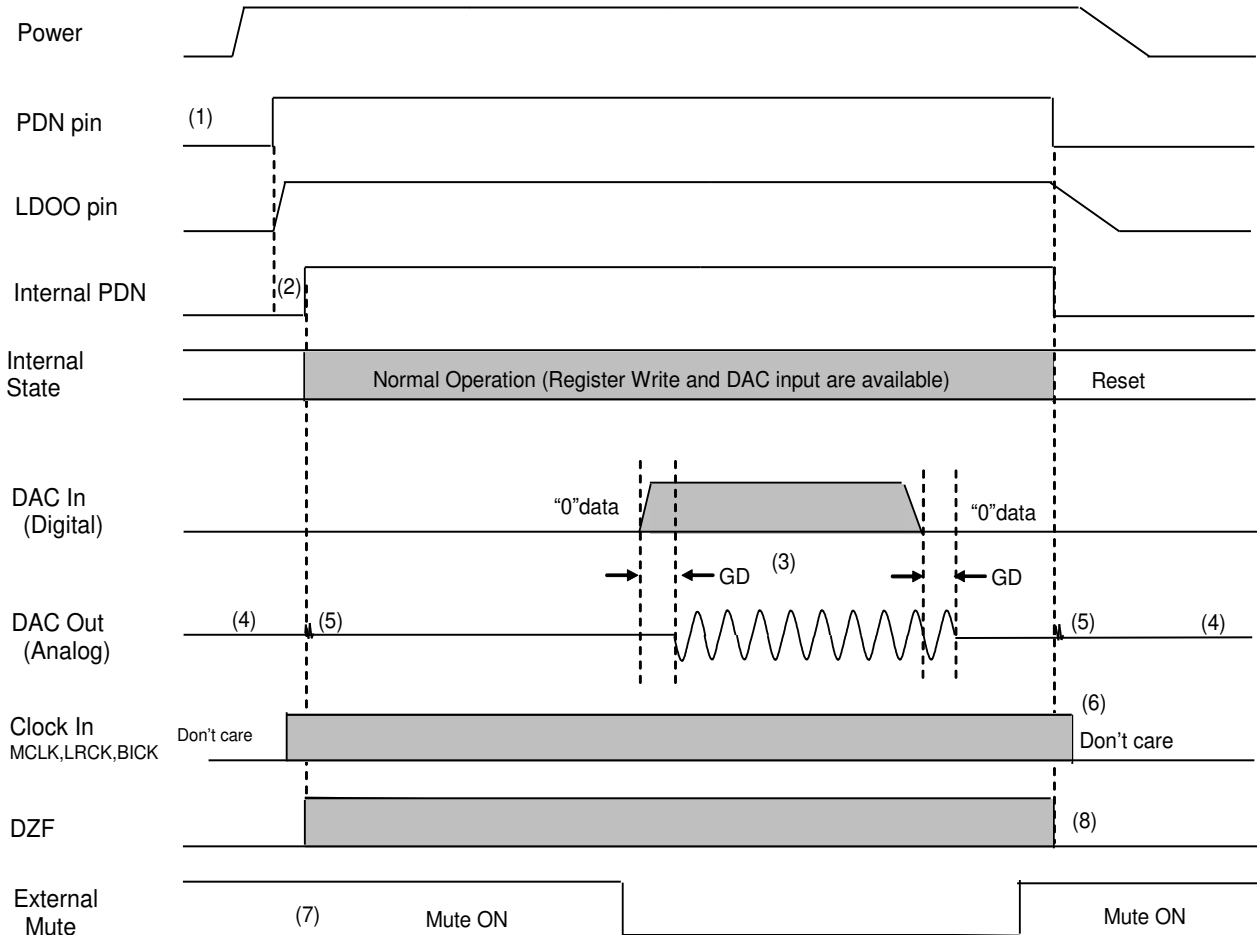

Notes:

- (1) After AVDD and TVDD are powered-up, the PDN pin should be “L” for 800ns.
- (2) After PDN pin = “H”, the internal LDO and VCOM power-up. The internal registers are initialized. Register writing is available in 1msec after PDN pin = “H”.
- (3) The analog output corresponding to digital input has group delay (GD).
- (4) Analog outputs are floating (Hi-Z) in power down mode.
- (5) Click noise occurs at an edge of PDN signal. This noise is output even if “0” data is input.
- (6) MCLK, BICK and LRCK clocks can be stopped in power-down mode (PDN pin= “L”).
- (7) Mute the analog output externally if click noise (5) adversely affect system performance. The timing example is shown in this figure.
- (8) The DZF pin outputs “L” in internal power-down mode.

Figure 31. Pin Power Down/Up Sequence Example

■ Power Off and Reset Functions

RSTN	PW4-1	Analog Output			
		DAC4	DAC3	DAC2	DAC1
0	0000	Hi-Z	Hi-Z	Hi-Z	Hi-Z
0	0001	Hi-Z	Hi-Z	Hi-Z	VCOM
0	0010	Hi-Z	Hi-Z	VCOM	Hi-Z
0	0011	Hi-Z	Hi-Z	VCOM	VCOM
0	0100	Hi-Z	VCOM	Hi-Z	Hi-Z
0	0101	Hi-Z	VCOM	Hi-Z	VCOM
0	0110	Hi-Z	VCOM	VCOM	Hi-Z
0	0111	Hi-Z	VCOM	VCOM	VCOM
0	1000	VCOM	Hi-Z	Hi-Z	Hi-Z
0	1001	VCOM	Hi-Z	Hi-Z	VCOM
0	1010	VCOM	Hi-Z	VCOM	Hi-Z
0	1011	VCOM	Hi-Z	VCOM	VCOM
0	1100	VCOM	VCOM	Hi-Z	Hi-Z
0	1101	VCOM	VCOM	Hi-Z	VCOM
0	1110	VCOM	VCOM	VCOM	Hi-Z
0	1111	VCOM	VCOM	VCOM	VCOM
1	0000	Hi-Z	Hi-Z	Hi-Z	Hi-Z
1	0001	Hi-Z	Hi-Z	Hi-Z	Normal
1	0010	Hi-Z	Hi-Z	Normal	Hi-Z
1	0011	Hi-Z	Hi-Z	Normal	Normal
1	0100	Hi-Z	Normal	Hi-Z	Hi-Z
1	0101	Hi-Z	Normal	Hi-Z	Normal
1	0110	Hi-Z	Normal	Normal	Hi-Z
1	0111	Hi-Z	Normal	Normal	Normal
1	1000	Normal	Hi-Z	Hi-Z	Hi-Z
1	1001	Normal	Hi-Z	Hi-Z	Normal
1	1010	Normal	Hi-Z	Normal	Hi-Z
1	1011	Normal	Hi-Z	Normal	Normal
1	1100	Normal	Normal	Hi-Z	Hi-Z
1	1101	Normal	Normal	Hi-Z	Normal
1	1110	Normal	Normal	Normal	Hi-Z
1	1111	Normal	Normal	Normal	Normal

Table 20. Power OFF and Reset Function

(1) Power OFF Function (PW4-1 bits)

All DAC4-1 can be powered down immediately by setting PW4-1 bits to "0000". In this time, the analog output goes to floating state (Hi-z). DACs will be reset and the digital block is powered down by setting RSTN bit to "0". In the reset state, the analog output becomes VCOM voltage if DAC is powered-up and MCLK, LRCK and BICK are supplied (Table 20). Internal register values are not initialized by power-off or reset by bit settings. Figure 32 shows a timing example of power-on and power-down.

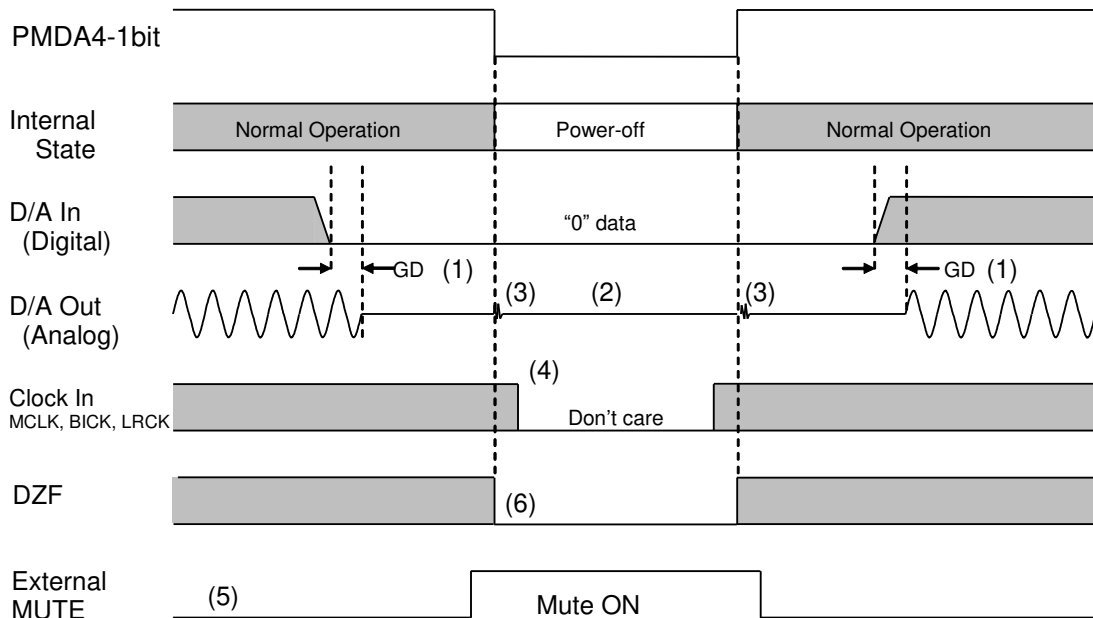

Notes:

- (1) The analog output corresponding to digital input has group delay (GD).
- (2) Analog outputs are floating (Hi-Z) in power down mode.
- (3) Click noise occurs at the edges ("↑ ↓") of the internal timing of PW4-1 bits. This noise is output even if "0" data is input.
- (4) Each clock input (MCLK, BICK, LRCK) can be stopped in power down mode (PW4-1 bits = "0000").
- (5) Mute the analog output externally if the click noise (3) adversely affect system performance.
- (6) The DZF pin outputs "L", in power down mode (PW4-1 bits = "0000").

Figure 32. Power-off/on Sequence Example

(2) Reset Function (RSTN bit)

The DAC can be reset by setting RSTN bit to "0" but the internal registers are not initialized. In this time, the corresponding analog outputs go to VCOM and the DZF pin outputs "H" if clocks (MCLK, BICK and LRCK) are input. Figure 33 shows an example of reset sequence by RSTN bit.

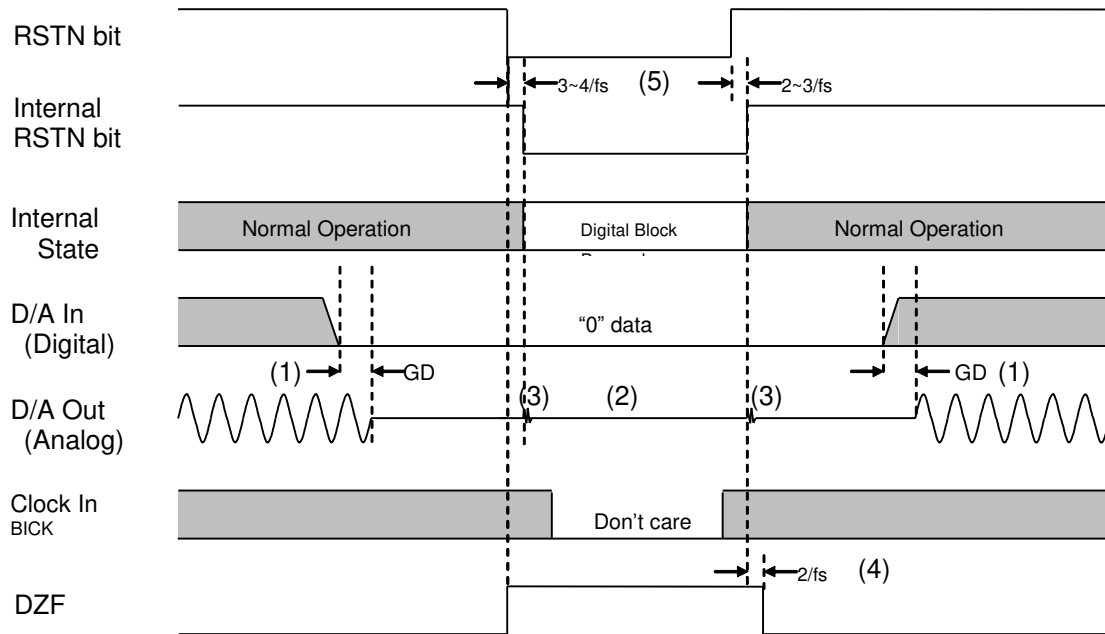

Notes:

- (1) The analog output corresponding to digital input has group delay (GD).
- (2) Analog outputs are VCOM in power down mode.
- (3) Click noise occurs at the edges ("↑↓") of the internal timing of RSTN bit. This noise is output even if "0" data is input.
- (4) The DZF pin goes to "H" on the falling edge of RSTN bit and goes to "L" in $2/f_s$ after a rising edge of the internal RSTN.
- (5) There is a delay, $3 \sim 4/f_s$ from RSTN bit "0" to the internal RSTN bit "0", and $2 \sim 3/f_s$ from RSTN bit "1" to the internal RSTN bit "1".

Figure 33. Reset Sequence Example

(3) Reset Function (MCLK)

The AK4438 is automatically placed in reset state when MCLK is stopped during normal operation (PDN pin = "H"), and the analog outputs go to VCOM voltage. When MCLK are input again, the AK4438 exits reset state and starts the operation. Zero detect function is disable when MCLK is stopped.

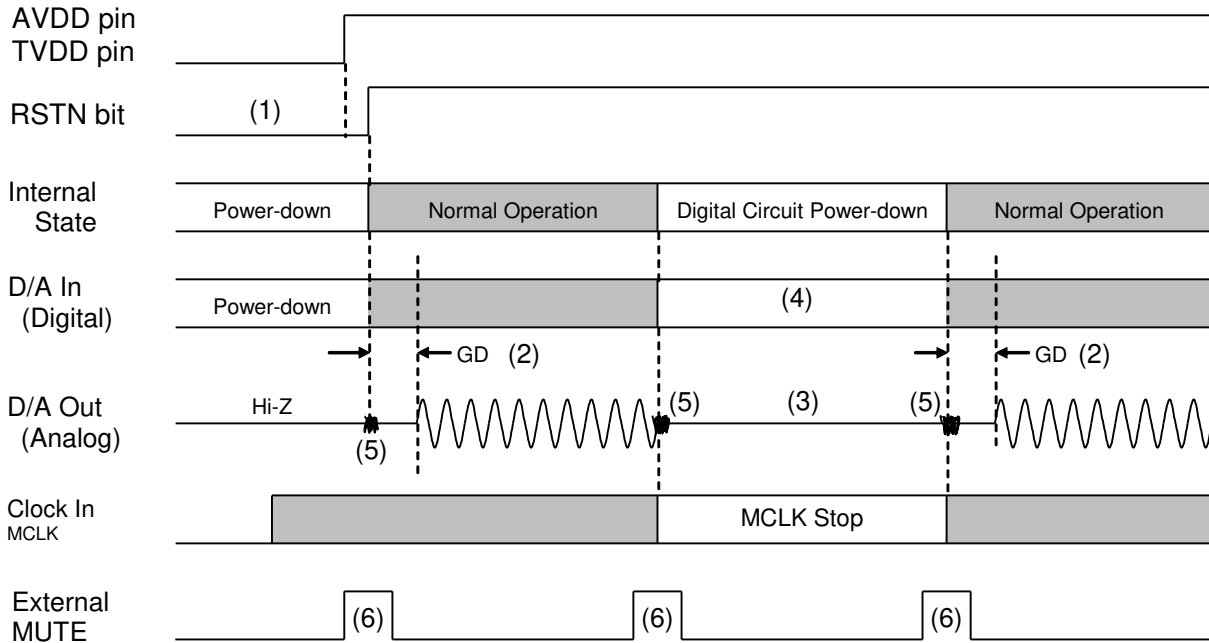

Notes:

- (1) After AVDD and TVDD are powered-up, the PDN pin should be "L" for 800ns.
- (2) The analog output corresponding to digital input has group delay (GD).
- (3) When MCLK is stopped, analog outputs go to VCOM voltage.
- (4) The digital data can be stopped. Click noise after MCLK is input again can be reduced by inputting "0" data during this period.
- (5) Click noise occurs within 3 ~ 4LRCK cycles from the rising edge ("↑") of the PDN pin or MCLK inputs. This noise occurs even when "0" data is input.
- (6) Mute the analog output externally if click noise (5) influences system applications. The timing example is shown in this figure.

Figure 34. Reset Sequence Example2

■ Clock Synchronization

The AK4438 has a function that resets the internal counter to keep a falling edge of the internal FSI clock is in $3/256f_s$ from an edge of the external FSI clock. Clock synchronization function becomes valid when data at all channels are continuously "0" for 8192 times if SYNCE bit is set to "1" during operation in PCM mode or when RSTN bit is set to "0". The operation clock is synchronized to a falling edge of LRCK in PCM mode and a rising edge of LRCK in I²C mode.

The analog output becomes VCOM voltage when RSTN bit = "0" or zero data is detected. Figure 35 shows a synchronization sequence when the input data is "0" for 8192 times continuously. Figure 36 shows a synchronization sequence by RSTN bit.

(1) Clock Synchronization Sequence when Input Data is "0" for 8192 Cycles Continuously

The DZF pin goes to "H" and the synchronization function becomes enabled when input data is "0" for 8192 time continuously including when the data is attenuated. Figure 35 shows a synchronization sequence.

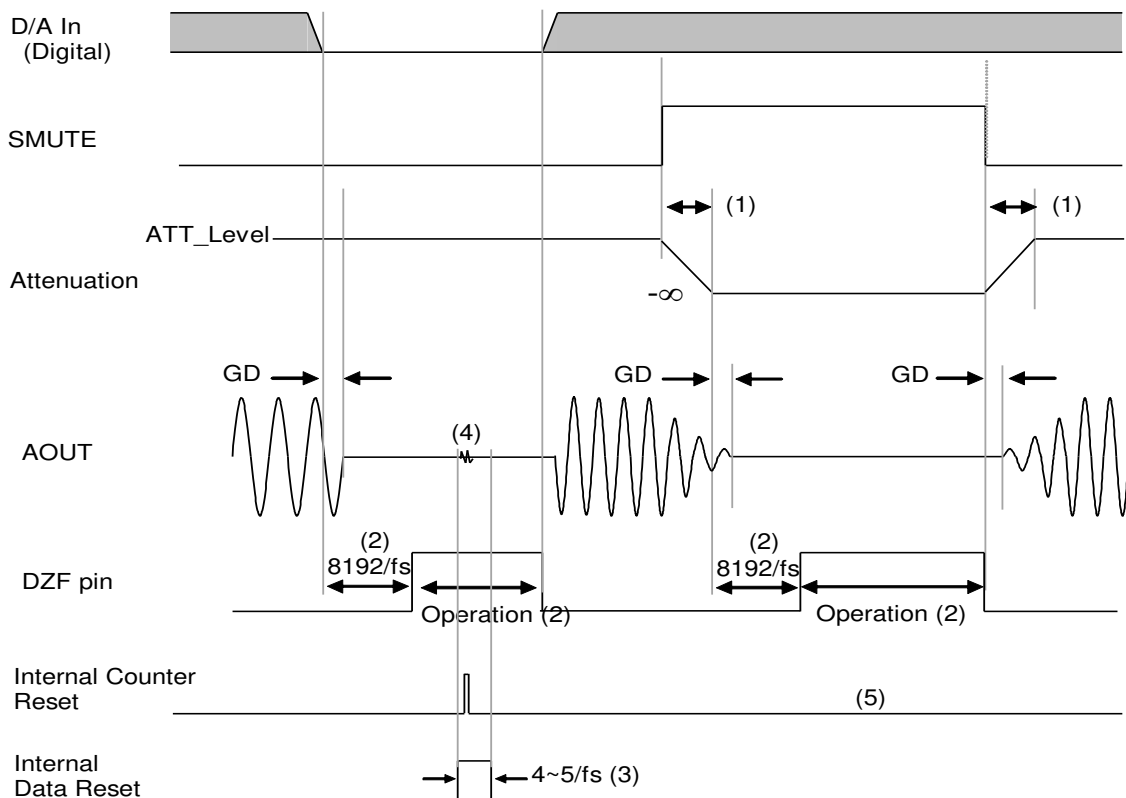

Notes:

- (1) Refer to Table 14 internal transition time of ATT.
- (2) The synchronization function becomes enabled when all channels input data are "0" for 8192 times continuously.
- (3) Internal data is fixed to "0" for $4 \sim 5/f_s$ forcibly when the internal counter is reset.
- (4) Click noise occurs when the internal counter is reset. This noise is output even if "0" data is input. Mute the analog output externally if this click noise adversely affects system performance.
- (5) The internal counter will not be reset when the internal and the external clocks are synchronized even if the synchronization function is enabled.

Figure 35. Clock Synchronization Sequence with Continuous Zero Data

(2) Clock Synchronization Sequence with RSTN-bit

The DZF pin outputs “H” by setting RSTN bit to “0”. The DAC is reset after $3\sim 4/f_s$ from the DZF pin = “H”, and the analog output goes to VCOM voltage. The synchronization function is enabled when the DZF pin = “H”. Figure 36 shows synchronization sequence with RSTN bit.

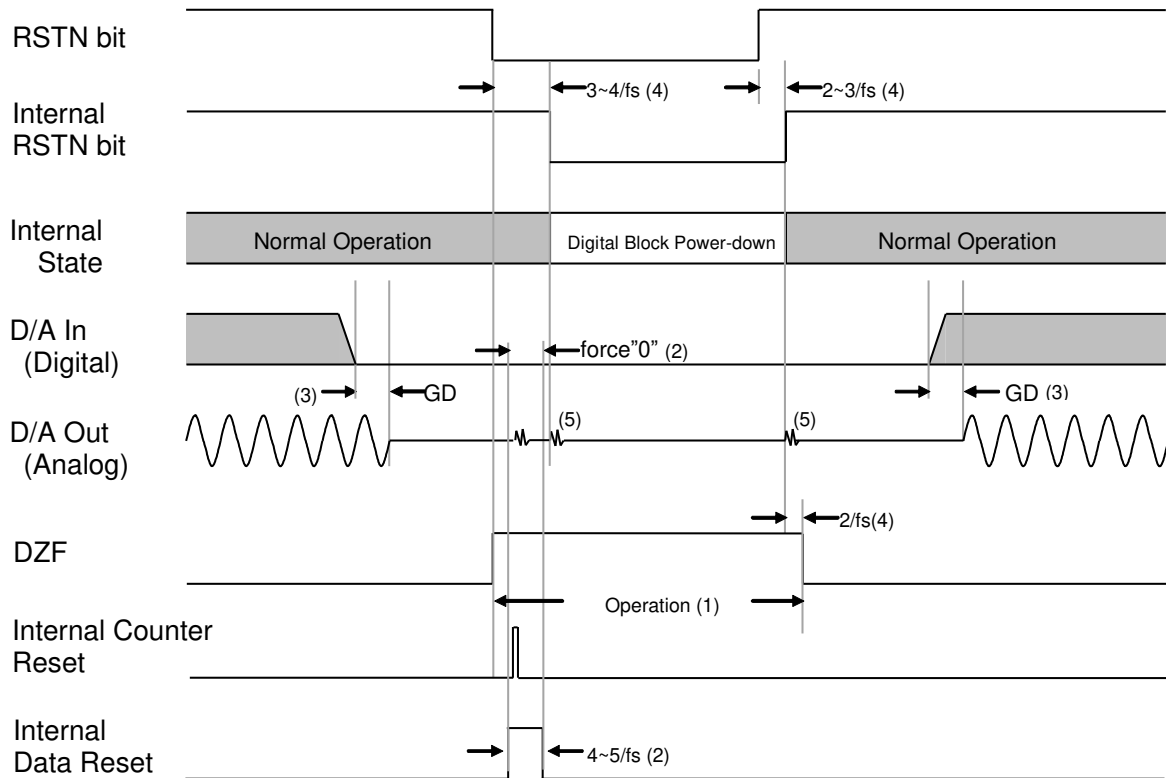

Notes:

- (1) The DZF pin outputs “H” by a falling edge of RSTN bit, and returns to “L” after $2/f_s$ from the internal rising edge of RSTN bit. During this period the synchronization function is enabled.
- (2) Internal data is fixed to “0” for $4\sim 5/f_s$ forcibly when the internal counter is reset.
- (3) The analog output corresponding to digital input has group delay (GD). It is recommended that when writing “0” data to RSTN bit, “0” period should be longer than the GD period.
- (4) It takes $3\sim 4/f_s$ to fall down and $2\sim 3/f_s$ to rise up for the internal RSTN signal from RSTN bit writing. There is a case that the internal counter is reset before internal RSTN bit is changed to “1” since the synchronization function becomes enabled immediately by setting RSTN bit = “0”.
- (5) A click noise occurs by an internal RSTN signal edge or an internal counter reset. This noise is output even if “0” data is input. Mute the analog output externally if the click noise adversely affects the system performance.

Figure 36. Clock Synchronization Sequence by RSTN bit

■ Parallel Mode

Parallel mode is available by setting the I2C pin = “H” and the PS pin = “H”. In parallel mode, the register setting is ignored. Audio interface format and soft mute function are controlled by Pins. Other functions operate in default setting of registers. The system clock is always in auto setting mode.

■ Audio Interface

Audio interface format of the parallel mode is controlled by TDM1-0 and DIF pins ([Table 21](#)). Zero detection function and functions set by registers are not available in parallel mode.

TDM1 pin	TDM0 pin	DIF pin	Mode
0	0	0	Mode6 (Table 9)
0	0	1	Mode7 (Table 9)
0	1	0	Mode12 (Table 9)
0	1	1	Mode13 (Table 9)
1	0	0	Mode18 (Table 9)
1	0	1	Mode19 (Table 9)
1	1	0	Mode24 (Table 9)
1	1	1	Mode25 (Table 9)

Table 21. Parallel Mode

■ Soft Mute

The soft mute operation is controlled by SMUTE pin ([Figure 30](#)).

■ Serial Control Interface

The AK4438's functions are controlled through registers. The registers may be written by two types of control modes. The internal registers are controlled in 3-wire serial control mode when the I2C pin = "L" and the PS pin = "L", and in I²C bus control mode when the I2C pin = "H" and the PS pin = "L". Chip address is determined by the CAD0 and CAD1 pins. The internal registers are initialized by setting the PDN pin to "L". The internal timing circuit is reset by setting RSTN bit = "0" but register values are not initialized..

*Register writings are not available when the PDN pin = "L".

(1) 3-wire Serial Control Mode (I2C pin = "L")

The internal registers may be written through the 3-wire μ P interface pins (CSN, CCLK and CDTI). The data on this interface consists of a 2-bit Chip address, Read/Write (1bit, Fixed to "1", Write only), Register address (MSB first, 5bits) and Control data (MSB first, 8bits). Address and data are clocked in on the rising edge of CCLK and data is clocked out on the falling edge. For write operations, data is latched after a low-to-high transition of CSN. The clock speed of CCLK is 5MHz (max).

The internal registers are initialized by setting the PDN pin = "L". In serial mode, the internal timing circuit is reset by setting RSTN bit = "0" but register values are not initialized.

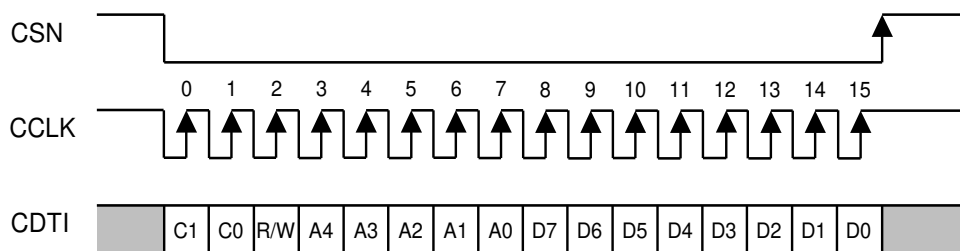

C1-C0: Chip Address (C1=CAD1, C0=CAD0)
 R/W: READ/WRITE (Fixed to "1", Write only)
 A4-A0: Register Address
 D7-D0: Control Data

Figure 37. Control I/F Timing

- * The AK4438 does not support read commands in 3-wire serial control mode.
- * When the AK4438 is in power down mode (PDN pin = "L"), a writing into the control registers is prohibited.
- * The control data cannot be written when the CCLK rising edge is 15 times or less, or 17 times or more during CSN is "L".

(2) I²C-bus Control Mode (I2C pin = "H")

The AK4438 supports the fast-mode I²C-bus (max: 400kHz, Ver1.0).

(2)-1. WRITE Operations

Figure 38 shows the data transfer sequence of the I²C-bus mode. All commands are preceded by a START condition. A HIGH to LOW transition on the SDA line while SCL is HIGH indicates a START condition (Figure 44). After the START condition, a slave address is sent. This address is 7 bits long followed by the eighth bit that is a data direction bit (R/W). The most significant five bits of the slave address are fixed as "00100". The next bits are CAD1-0 (device address bits). These bits identify the specific device on the bus. The hard-wired input pins (CAD1-0 pins) set these device address bits (Figure 39). If the slave address matches that of the AK4438, the AK4438 generates an acknowledge and the operation is executed. The master must generate the acknowledge-related clock pulse and release the SDA line (HIGH) during the acknowledge clock pulse (Figure 45). R/W bit = "1" indicates that the read operation is to be executed. "0" indicates that the write operation is to be executed.

The second byte consists of the control register address of the AK4438. The format is MSB first, and those most significant 3-bits are fixed to zeros (Figure 40). The data after the second byte contains control data. The format is MSB first, 8bits (Figure 41). The AK4438 generates an acknowledge after each byte is received. Data transfer is always terminated by a STOP condition generated by the master. A LOW to HIGH transition on the SDA line while SCL is HIGH defines STOP condition (Figure 44).

The AK4438 can perform more than one byte write operation per sequence. After receipt of the third byte the AK4438 generates an acknowledge and awaits the next data. The master can transmit more than one byte instead of terminating the write cycle after the first data byte is transferred. After receiving each data packet the internal address counter is incremented by one, and the next data is automatically taken into the next address. If the address exceeds "14H" prior to generating a stop condition, the address counter will "roll over" to "00H" and the previous data will be overwritten.

The data on the SDA line must remain stable during the HIGH period of the clock. The HIGH or LOW state of the data line can only be changed when the clock signal on the SCL line is LOW (Figure 46) except for the START and STOP conditions.

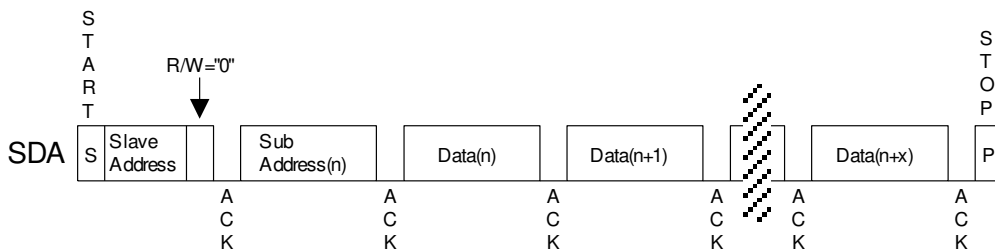

Figure 38. Data Transfer Sequence at the I²C-Bus Mode

0	0	1	0	0	CAD1	CAD0	R/W
---	---	---	---	---	------	------	-----

(CAD1 and CAD0 are determined by pin settings)

Figure 39. The First Byte

0	0	0	A4	A3	A2	A1	A0
---	---	---	----	----	----	----	----

Figure 40. The Second Byte

D7	D6	D5	D4	D3	D2	D1	D0
----	----	----	----	----	----	----	----

Figure 41. Byte Structure After The Second Byte

(2)-2. READ Operations

Set the R/W bit = "1" for the READ operation of the AK4438. After transmission of data, the master can read the next address's data by generating an acknowledge instead of terminating the write cycle after the receipt of the first data word. After receiving each data packet the internal address counter is incremented by one, and the next data is automatically taken into the next address. If the address exceeds "14H" prior to generating stop condition, the address counter will "roll over" to "00H" and the data of "00H" will be read out.

The AK4438 supports two basic read operations: Current Address Read and Random Address Read.

(2)-2-1. Current Address Read

The AK4438 contains an internal address counter that maintains the address of the last word accessed, incremented by one. Therefore, if the last access (either a read or write) was to address "n", the next CURRENT READ operation would access data from the address "n+1". After receipt of the slave address with R/W bit "1", the AK4438 generates an acknowledge, transmits 1-byte of data to the address set by the internal address counter and increments the internal address counter by 1. If the master does not generate an acknowledge but generates a stop condition instead, the AK4438 ceases transmission.

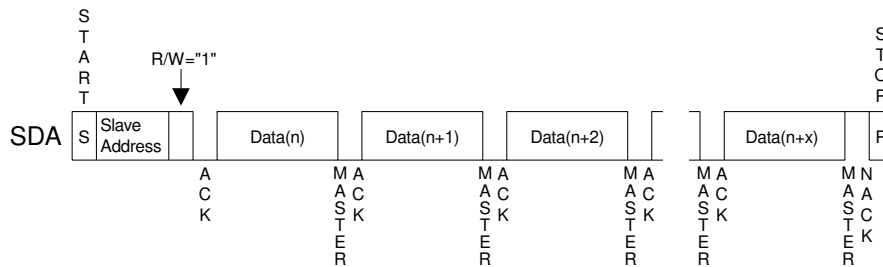

Figure 42. Current Address Read

(2)-2-2. Random Address Read

The random read operation allows the master to access any memory location at random. Prior to issuing a slave address with the R/W bit = "1", the master must execute a "dummy" write operation first. The master issues a start request, a slave address (R/W bit = "0") and then the register address to read. After the register address is acknowledged, the master immediately reissues the start request and the slave address with the R/W bit = "1". The AK4438 then generates an acknowledge, 1 byte of data and increments the internal address counter by 1. If the master does not generate an acknowledge but generates a stop condition instead, the AK4438 ceases transmission.

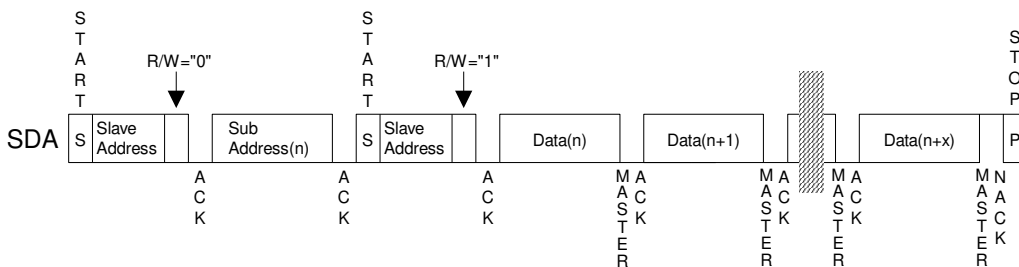

Figure 43. Random Address Read

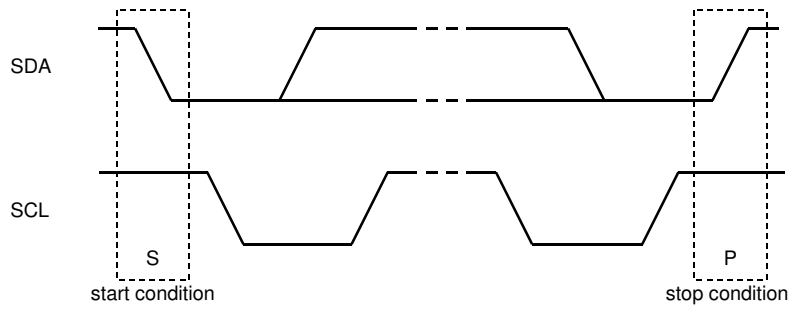

Figure 44. START and STOP Conditions

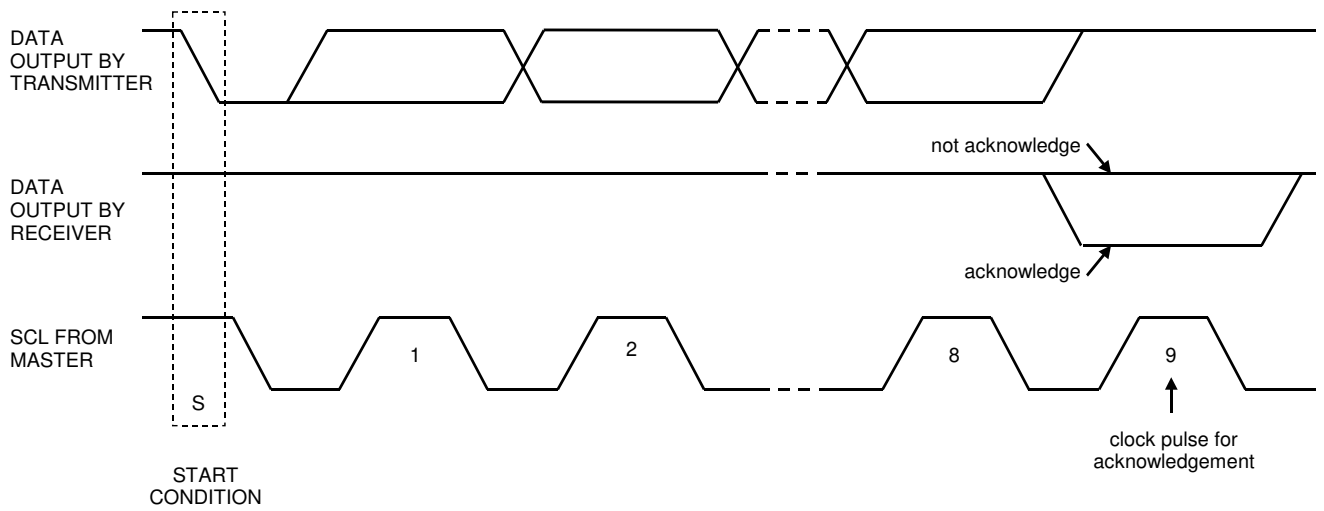

Figure 45. Acknowledge on the I²C-Bus

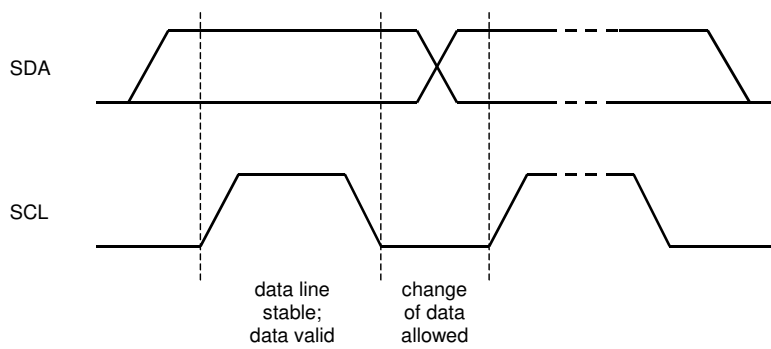

Figure 46. Bit Transfer on the I²C-Bus

■ Register Map

Addr	Register Name	D7	D6	D5	D4	D3	D2	D1	D0
00H	Control 1	ACKS	0	0	0	DIF2	DIF1	DIF0	RSTN
01H	Control 2	0	0	SD	DFS1	DFS0	DEM11	DEM10	SMUTE
02H	Control 3	0	0	0	0	MONO1	DZFB	SELLR1	SLOW
03H	L1ch ATT	ATT7	ATT6	ATT5	ATT4	ATT3	ATT2	ATT1	ATT0
04H	R1ch ATT	ATT7	ATT6	ATT5	ATT4	ATT3	ATT2	ATT1	ATT0
05H	Control 4	INVL1	INVR1	INVL2	INVR2	SELLR2	0	DFS2	SSLOW
06H	-	0	0	0	0	0	0	0	0
07H	Control 6	L3	R3	L4	R4	0	0	0	SYNCE
08H	Control 7	L1	R1	L2	R2	0	0	0	0
09H	-	0	0	0	0	0	0	0	0
0AH	Control 8	TDM1	TDM0	SDS1	SDS2	PW2	PW1	DEM21	DEM20
0BH	Control 9	ATS1	ATS0	0	SDS0	PW4	PW3	0	0
0CH	Control 10	INVR4	INVL4	INVR3	INVL3	0	0	0	0
0DH	Control 11	MONO4	MONO3	MONO2	0	SELLR4	SELLR3	0	0
0EH	Control 12	DEM41	DEM40	DEM31	DEM30	0	0	0	0
0FH	L2ch ATT	ATT7	ATT6	ATT5	ATT4	ATT3	ATT2	ATT1	ATT0
10H	R2ch ATT	ATT7	ATT6	ATT5	ATT4	ATT3	ATT2	ATT1	ATT0
11H	L3ch ATT	ATT7	ATT6	ATT5	ATT4	ATT3	ATT2	ATT1	ATT0
12H	R3ch ATT	ATT7	ATT6	ATT5	ATT4	ATT3	ATT2	ATT1	ATT0
13H	L4ch ATT	ATT7	ATT6	ATT5	ATT4	ATT3	ATT2	ATT1	ATT0
14H	R4ch ATT	ATT7	ATT6	ATT5	ATT4	ATT3	ATT2	ATT1	ATT0

Notes: Data must not be written into addresses from 15H to 1FH.

The bit defined as 0 must contain a "0" value.

When the PDN pin goes to "L", the registers are initialized to their default values.

When RSTN bit goes to "0", the internal timing is reset, but registers are not initialized.

■ Register Definitions

Addr	Register Name	D7	D6	D5	D4	D3	D2	D1	D0
00H	Control 1	ACKS	0	0	0	DIF2	DIF1	DIF0	RSTN
	R/W	R/W	R/W	R/W	R/W	R/W	R/W	R/W	R/W
	Default	0	0	0	0	1	1	0	1

RSTN: Internal Timing Reset

0: Reset The DZF pin goes “H” but register values are not initialized.

1: Normal Operation (default)

DIF2-0: Audio Data Interface Modes ([Table 9](#))

Default value is “110” (Mode 6: 32-bit MSB justified).

ACKS: Master Clock Frequency Auto Setting Mode Enable

0: Disable, Manual Setting Mode (default)

1: Enable, Auto Setting Mode

When ACKS bit = “1”, the MCLK frequency is detected automatically.

Addr	Register Name	D7	D6	D5	D4	D3	D2	D1	D0
01H	Control 2	0	0	SD	DFS1	DFS0	DEM11	DEM10	SMUTE
	R/W	R/W	R/W	R/W	R/W	R/W	R/W	R/W	R/W
	Default	0	0	1	0	0	0	1	0

SMUTE: Soft Mute Enable.

0: Normal Operation (default)

1: DAC outputs soft-muted.

DEM11-0: DAC1 De-emphasis Response ([Table 8](#))

Default value is “01” (OFF).

DFS2-0: Sampling Speed Control ([Table 1](#))

Default value is “000” (Normal Speed).

A click noise occurs when switching DFS2-0 bits setting.

SD: Short delay Filter Enable. ([Table 11](#))

0: Sharp roll off filter or Slow roll off filter

1: Short delay Sharp roll off filter or Short delay Slow roll off filter (default)

Addr	Register Name	D7	D6	D5	D4	D3	D2	D1	D0
02H	Control 3	0	0	0	0	MONO1	DZFB	SELLR1	SLOW
	R/W	R/W	R/W	R/W	R/W	R/W	R/W	R/W	R/W
	Default	0	0	0	0	0	0	0	0

SLOW: Slow Roll-off Filter Enable ([Table 11](#))

0: Sharp Roll-off Filter (default)

1: Slow Roll-off Filter

SELLR1: The data selection of DAC1 ([Table 15](#))

Default value is "0"

DZB: Inverting Enable of DZF ([Table 12](#))

0: DZF pin goes "H" at Zero Detection (default)

1: DZF pin goes "L" at Zero Detection

MONO1: DAC1 enters monaural output mode when MONO bit = "1" ([Table 15](#)).

0: Stereo mode (default)

1: MONO mode

Addr	Register Name	D7	D6	D5	D4	D3	D2	D1	D0
03H	L1ch ATT	ATT7	ATT6	ATT5	ATT4	ATT3	ATT2	ATT1	ATT0
04H	R1ch ATT	ATT7	ATT6	ATT5	ATT4	ATT3	ATT2	ATT1	ATT0
	R/W	R/W	R/W	R/W	R/W	R/W	R/W	R/W	R/W
	Default	1	1	1	1	1	1	1	1

ATT7-0: Attenuation Level ([Table 13](#))

Default value is "FF" (0dB)

Addr	Register Name	D7	D6	D5	D4	D3	D2	D1	D0
05H	Control 4	INVL1	INVR1	INVL2	INVR2	SELLR2	0	DFS2	SSLOW
	R/W	R/W	R/W	R/W	R/W	R/W	R/W	R/W	R/W
	Default	0	0	0	0	0	0	0	0

SSLOW: Digital Filter bypass mode Enable ([Table 11](#))

0: Disable (default)

1: Enable

DFS2-0: Sampling Speed Control ([Table 1](#))

Default value is "000" (Normal Speed).

A click noise occurs when switching DFS2-0 bits setting.

SELLR2: The data selection of DAC2 ([Table 16](#))

Default value is "0"

INVL1: AOUTL1 Output Phase Inverting Bit ([Table 15](#))

INVR1: AOUTR1 Output Phase Inverting Bit ([Table 15](#))

INVL2: AOUTL2 Output Phase Inverting Bit ([Table 16](#))

INVR2: AOUTR2 Output Phase Inverting Bit ([Table 16](#))

0: Normal (default)

1: Inverted

Addr	Register Name	D7	D6	D5	D4	D3	D2	D1	D0
07H	Control 6	L3	R3	L4	R4	0	0	0	SYNCE
	R/W	R/W	R/W	R/W	R/W	R/W	R/W	R/W	R/W
	Default	0	0	0	0	0	0	0	1

SYNCE: SYNC Mode Enable
 0: SYNC Mode Disable
 1: SYNC Mode Enable (default)

L3-4, R3-4: Zero Detect Flag Enable Bit for the DZF pin
 0: Disable(default)
 1: Enable

Addr	Register Name	D7	D6	D5	D4	D3	D2	D1	D0
08H	Control 7	L1	R1	L2	R2	0	0	0	0
	R/W	R/W	R/W	RD	RD	R/W	R/W	R/W	R/W
	Default	0	0	0	0	0	0	0	0

L1-2, R1-2: Zero Detect Flag Enable Bit for the DZF pin
 0: Disable(default)
 1: Enable

Addr	Register Name	D7	D6	D5	D4	D3	D2	D1	D0
0AH	Control 8	TDM1	TDM0	SDS1	SDS2	PW2	PW1	DEM21	DEM20
	R/W	R/W	R/W	R/W	R/W	R/W	R/W	R/W	R/W
	Default	0	0	0	0	1	1	0	1

DEM21-20: DAC2 De-emphasis Response ([Table 8](#))
 Default value is "01". (OFF)

PW2-1: Power Down control for DAC
 PW2: Power management for DAC2
 0: DAC2 power OFF
 1: DAC2 power ON (default)
 PW1: Power management for DAC1
 0: DAC1 power OFF
 1: DAC1 power ON (default)

SDS2-0: DAC1-4 Data Select
 0: Normal Operation
 1: Output Other Slot Data ([Table 10](#))
 Default value is "000".

TDM1-0: TDM Mode Select ([Table 9](#))
 Default value is "00".

Addr	Register Name	D7	D6	D5	D4	D3	D2	D1	D0
0BH	Control 9	ATS1	ATS0	0	SDS0	PW4	PW3	0	0
	R/W	R/W	R/W	R/W	R/W	R/W	R/W	R/W	R/W
	Default	0	0	0	0	1	1	0	0

PW4-3: Power Down control for DAC
 PW4: Power management for DAC4
 0: DAC4 power OFF
 1: DAC4 power ON (default)
 PW3: Power management for DAC3
 0: DAC3 power OFF
 1: DAC3 power ON (default)

SDS2-0: DAC1-4 Data Select
 0: Normal Operation
 1: Output Other Slot Data ([Table 10](#))
 The default value is "000".

ATS1-0: Transition Time between Set Values of ATT7-0 bits ([Table 14](#))
 The default value is "00".

Addr	Register Name	D7	D6	D5	D4	D3	D2	D1	D0
0CH	Control 6	INVR4	INVL4	INVR3	INVL3	0	0	0	0
	R/W	R/W	R/W	R/W	R/W	R/W	R/W	R/W	R/W
	Default	0	0	0	0	0	0	0	0

INVL3: AOUTL3 Output Phase Inverting Bit ([Table 17](#))
 INVR3: AOUTR3 Output Phase Inverting Bit ([Table 17](#))
 INVL4: AOUTL4 Output Phase Inverting Bit ([Table 18](#))
 INVR4: AOUTR4 Output Phase Inverting Bit ([Table 18](#))
 0: Normal (default)
 1: Inverted

Addr	Register Name	D7	D6	D5	D4	D3	D2	D1	D0
0DH	Control 6	MONO4	MONO3	MONO2	0	SELLR4	SELLR3	0	0
	R/W	R/W	R/W	R/W	R/W	R/W	R/W	R/W	R/W
	Default	0	0	0	0	0	0	0	0

SELLR3: The data selection of DAC3 ([Table 17](#))
 SELLR4: The data selection of DAC4 ([Table 18](#))
 The default value is "0".

MONO2: DAC2 enters Mono output mode when MONO2 bit = "1". ([Table 16](#))
 MONO3: DAC3 enters Mono output mode when MONO3 bit = "1". ([Table 17](#))
 MONO4: DAC4 enters Mono output mode when MONO4 bit = "1". ([Table 18](#))
 0: Stereo mode (default)
 1: MONO mode

Addr	Register Name	D7	D6	D5	D4	D3	D2	D1	D0
0EH	Control 6	DEM41	DEM40	DEM31	DEM30	0	0	0	0
R/W		R/W	R/W	R/W	R/W	R/W	R/W	R/W	R/W
Default		0	1	0	1	0	0	0	0

DEM31-30: DAC3 De-emphasis Response ([Table 8](#))

DEM41-40: DAC4 De-emphasis Response ([Table 8](#))

The default value is "01", OFF

Addr	Register Name	D7	D6	D5	D4	D3	D2	D1	D0
0FH	L2ch ATT	ATT7	ATT6	ATT5	ATT4	ATT3	ATT2	ATT1	ATT0
10H	R2ch ATT	ATT7	ATT6	ATT5	ATT4	ATT3	ATT2	ATT1	ATT0
11H	L3ch ATT	ATT7	ATT6	ATT5	ATT4	ATT3	ATT2	ATT1	ATT0
12H	R3ch ATT	ATT7	ATT6	ATT5	ATT4	ATT3	ATT2	ATT1	ATT0
13H	L4ch ATT	ATT7	ATT6	ATT5	ATT4	ATT3	ATT2	ATT1	ATT0
14H	R4ch ATT	ATT7	ATT6	ATT5	ATT4	ATT3	ATT2	ATT1	ATT0
R/W		R/W	R/W	R/W	R/W	R/W	R/W	R/W	R/W
Default		1	1	1	1	1	1	1	1

ATT7-0: Attenuation Level ([Table 13](#))

The default value is "FF", (0dB)

13. Recommended External Circuits

■ Typical Connection Diagram

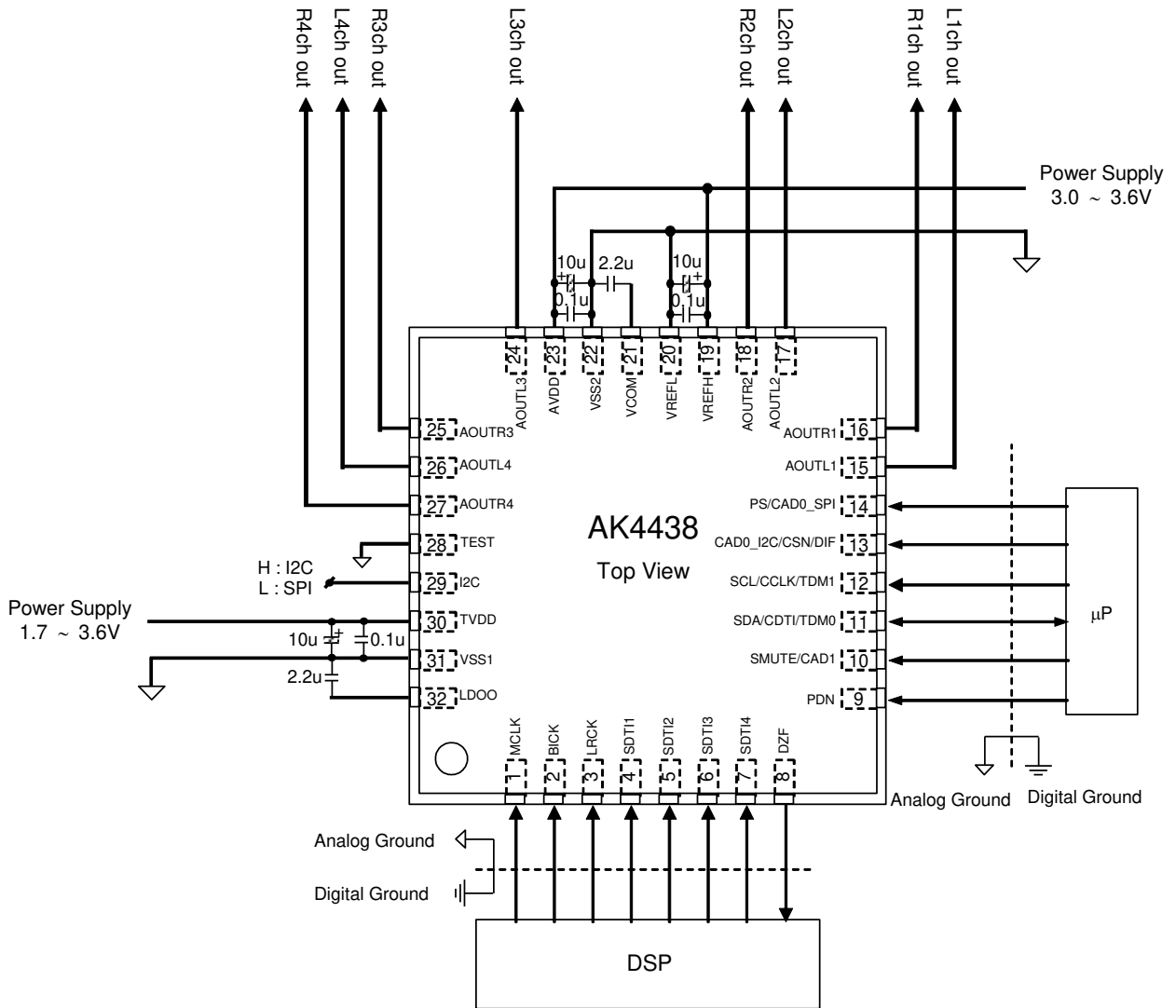

Figure 47. Typical Connection Diagram

Note: The AK4438 integrates smoothing filters.

1. Grounding and Power Supply Decoupling

The AK4438 requires careful attention to power supply and grounding arrangements. AVDD and TVDD are usually supplied from the analog supply of the system. If AVDD and TVDD are supplied separately, the power-up sequences between AVDD and TVDD is not critical. **VSS1 and VSS2 must be connected to the same analog ground plane.** System analog ground and digital ground should be wired separately and connected together as close as possible to where the supplies are brought onto the printed circuit board. Decoupling capacitors should be as near to the AK4438 as possible.

2. Voltage Reference

The differential voltage between VREFH pin and VREFL pin sets the analog output range. The VREFH pin is normally connected to AVDD, and the VREFL pin is normally connected to VSS2. VREFHL and VREFL should be connected with a 0.1 μ F ceramic capacitor and 10 μ F electrolytic capacitor as near as possible to the pin to eliminate the effects of high frequency noise.

VCOM is a signal ground of this chip and output the voltage AVDDx1/2. A 2.2 μ F \pm 50% ceramic capacitor attached between the VCOM pin and VSS2 eliminates the effects of high frequency noise. This capacitor should be as close to the pin as possible. No load current may be drawn from the VCOM pin. All signals, especially clocks, should be kept away from the VREFH pin and the VCOM pin in order to avoid unwanted coupling into the AK4438.

LDOO outputs 1.2V that is used for internal digital circuit. LDOO and VSS1 should be connected with a 2.2 μ F \pm 50% ceramic capacitor as near as possible to the pin to stabilize internal LDO. No load current may be drawn from the VCOM pin.

3. Analog Output

The output signal range is nominally 0.86 x VREFH Vpp centered around the VCOM voltage. The DAC input data format is 2's complement. The output voltage is a positive full scale for 7FFFFFFFH (@32bit) and a negative full scale for 80000000H (@32bit). The ideal output is VCOM voltage for 00000000H (@32bit). The internal analog filters remove most of the noise generated by the delta-sigma modulator of DAC beyond the audio passband, in single-ended input mode.

Normally, DC component is cut by an external capacitor since the DAC outputs have DC offsets of a few millivolts to the VCOM voltage.

4. External Analog Outputs Circuit

The output level of this circuit is 2.83Vpp (AK4438: typ. 2.83Vpp). Normally, DC component is cut by an external capacitor since the DAC outputs have DC offsets of a few millivolts to the VCOM voltage. The cutoff frequency of HPF is shown below.

$$f_c = 1 / (2 \times \pi \times R \times C) \text{ [Hz]}$$

Where the C is the external AC coupling capacitor and the R is load resistance. When C = 1 μ F and R = 10k Ω , then f_s = 16Hz.

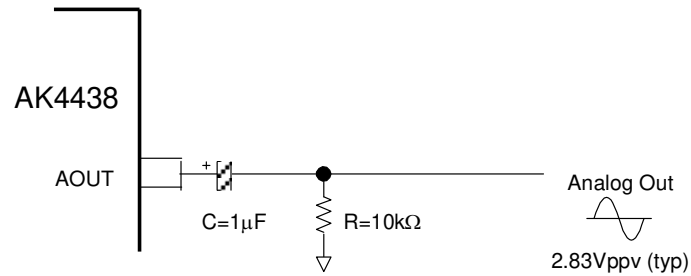
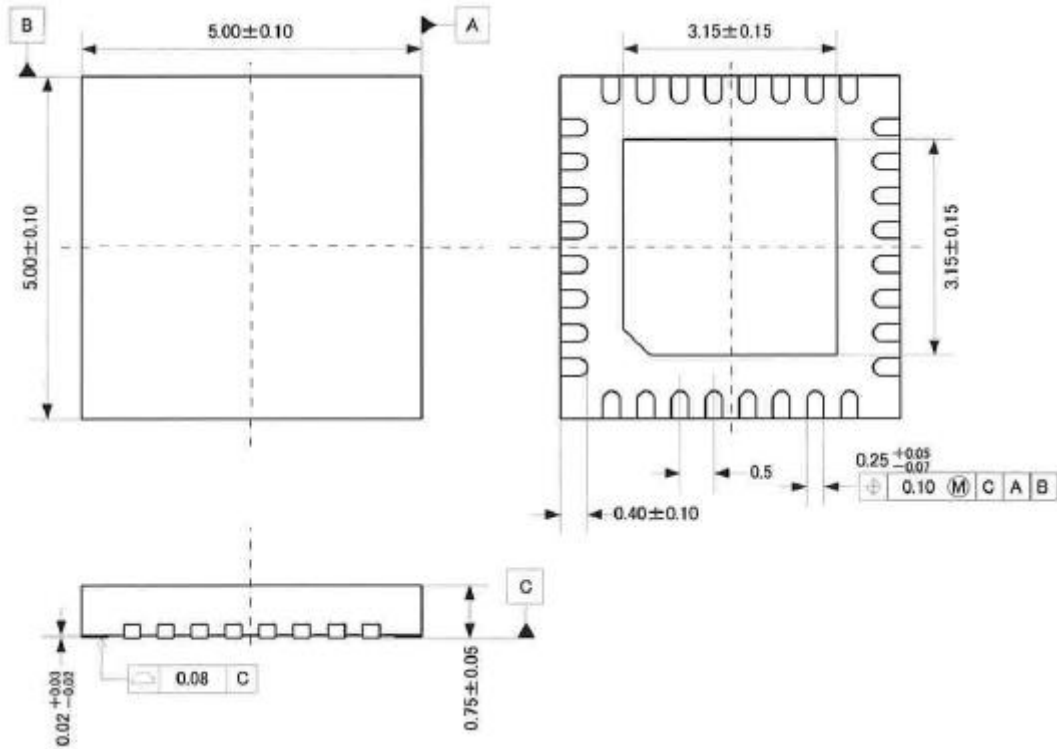

Figure 48. Output Buffer Circuit Example

14. Package

■ **Outline Dimensions**

32-pin QFN (Unit: mm)



■ **Material & Lead Finish**

Package molding compound: Epoxy, Halogen (Br and Cl) free
 Lead frame material: Cu
 Terminal surface treatment: Solder (Pb free) plate

■ **Marking**

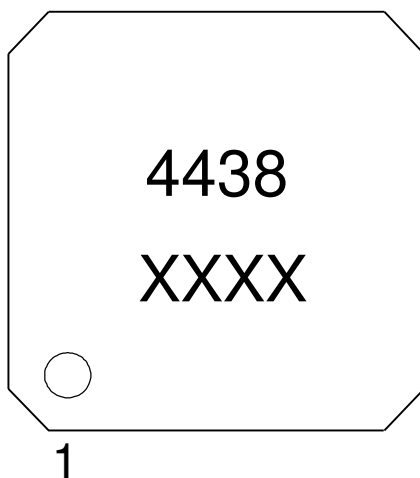

- 1) Pin #1 indication
- 2) Date Code: XXXX (4 digits)
- 3) Marking Code: 4438

15. Ordering Guide

■ **Ordering Guide**

AK4438VN -40 ~ +105°C 32-pin QFN (0.5mm pitch)
 AKD4438 Evaluation Board for the AK4438

16. Revision History

Date (Y/M/D)	Revision	Reason	Page	Contents
16/03/04	00	First Edition		

IMPORTANT NOTICE

0. Asahi Kasei Microdevices Corporation ("AKM") reserves the right to make changes to the information contained in this document without notice. When you consider any use or application of AKM product stipulated in this document ("Product"), please make inquiries the sales office of AKM or authorized distributors as to current status of the Products.
1. All information included in this document are provided only to illustrate the operation and application examples of AKM Products. AKM neither makes warranties or representations with respect to the accuracy or completeness of the information contained in this document nor grants any license to any intellectual property rights or any other rights of AKM or any third party with respect to the information in this document. You are fully responsible for use of such information contained in this document in your product design or applications. AKM ASSUMES NO LIABILITY FOR ANY LOSSES INCURRED BY YOU OR THIRD PARTIES ARISING FROM THE USE OF SUCH INFORMATION IN YOUR PRODUCT DESIGN OR APPLICATIONS.
2. The Product is neither intended nor warranted for use in equipment or systems that require extraordinarily high levels of quality and/or reliability and/or a malfunction or failure of which may cause loss of human life, bodily injury, serious property damage or serious public impact, including but not limited to, equipment used in nuclear facilities, equipment used in the aerospace industry, medical equipment, equipment used for automobiles, trains, ships and other transportation, traffic signaling equipment, equipment used to control combustions or explosions, safety devices, elevators and escalators, devices related to electric power, and equipment used in finance-related fields. Do not use Product for the above use unless specifically agreed by AKM in writing.
3. Though AKM works continually to improve the Product's quality and reliability, you are responsible for complying with safety standards and for providing adequate designs and safeguards for your hardware, software and systems which minimize risk and avoid situations in which a malfunction or failure of the Product could cause loss of human life, bodily injury or damage to property, including data loss or corruption.
4. Do not use or otherwise make available the Product or related technology or any information contained in this document for any military purposes, including without limitation, for the design, development, use, stockpiling or manufacturing of nuclear, chemical, or biological weapons or missile technology products (mass destruction weapons). When exporting the Products or related technology or any information contained in this document, you should comply with the applicable export control laws and regulations and follow the procedures required by such laws and regulations. The Products and related technology may not be used for or incorporated into any products or systems whose manufacture, use, or sale is prohibited under any applicable domestic or foreign laws or regulations.
5. Please contact AKM sales representative for details as to environmental matters such as the RoHS compatibility of the Product. Please use the Product in compliance with all applicable laws and regulations that regulate the inclusion or use of controlled substances, including without limitation, the EU RoHS Directive. AKM assumes no liability for damages or losses occurring as a result of noncompliance with applicable laws and regulations.
6. Resale of the Product with provisions different from the statement and/or technical features set forth in this document shall immediately void any warranty granted by AKM for the Product and shall not create or extend in any manner whatsoever, any liability of AKM.
7. This document may not be reproduced or duplicated, in any form, in whole or in part, without prior written consent of AKM.