

### Features

Frequency range : 32.768 kHz  
 SMD seam sealing ceramic package  
 Supply voltage : 1.8V ~ 3.3V  
 CMOS output  
 Tri-state function available  
 External dimensions (mm)  
 L : 3.2 x W : 2.5 x H : 1.0  
 RoHS compliant & Pb free

### Applications

Real-time clock (RTC)  
 WLAN, NFC, SiP Modules  
 PC, NB, Tablet, Computer peripherals  
 Audio, Video, Gaming, DSC, STB  
 Server, Switch, Router  
 Security devices, Smart meters  
 Consumer products  
 Internet of Things (IoT)

### Electrical Characteristics

Item	7XZ	Conditions
Frequency Range ( $F_0$ )	32.768 kHz	
Frequency Stability ( $F_{stab}$ )	$\pm 25$ ppm	-10°C ~ +70°C
	$\pm 50$ ppm, $\pm 25$ ppm	-40°C ~ +85°C
Operating Temperature Range ( $T_{OTR}$ )	-10°C ~ +70°C	
	-40°C ~ +85°C	
Supply Voltage ( $V_{DD}$ )	1.8V, 2.5V, 3.3V	$V_{DD} \pm 10\%$
Current Consumption ( $I_{DD}$ )	3 mA Max.	
Output Type	CMOS	
Output Load ( $C_L$ )	15 pF	
Output Voltage High ( $V_{OH}$ )	90% $V_{DD}$ Min.	
Output Voltage Low ( $V_{OL}$ )	10% $V_{DD}$ Max.	
Rise & Fall Time ( $T_r / T_f$ )	200 ns Max.	10% ~ 90% of $V_{DD}$
Duty Cycle	45% ~ 55%	
Start-up Time	10 ms Max.	
Enable Voltage High, Logic "1"	70% $V_{DD}$ Min.	Input to Pin1 Note [1]
Enable Voltage Low, Logic "0"	30% $V_{DD}$ Max.	
Aging ( $F_{aging}$ )	$\pm 5$ ppm Max.	at 25°C $\pm 3$ °C, first year
Storage Temperature Range ( $T_{STR}$ )	-55°C ~ +125°C	

#### Notes:

[1] Output will be enable if Pin1 is Logic "1" or Open; Output will be disable if Pin1 is Logic "0".

## Dimensions

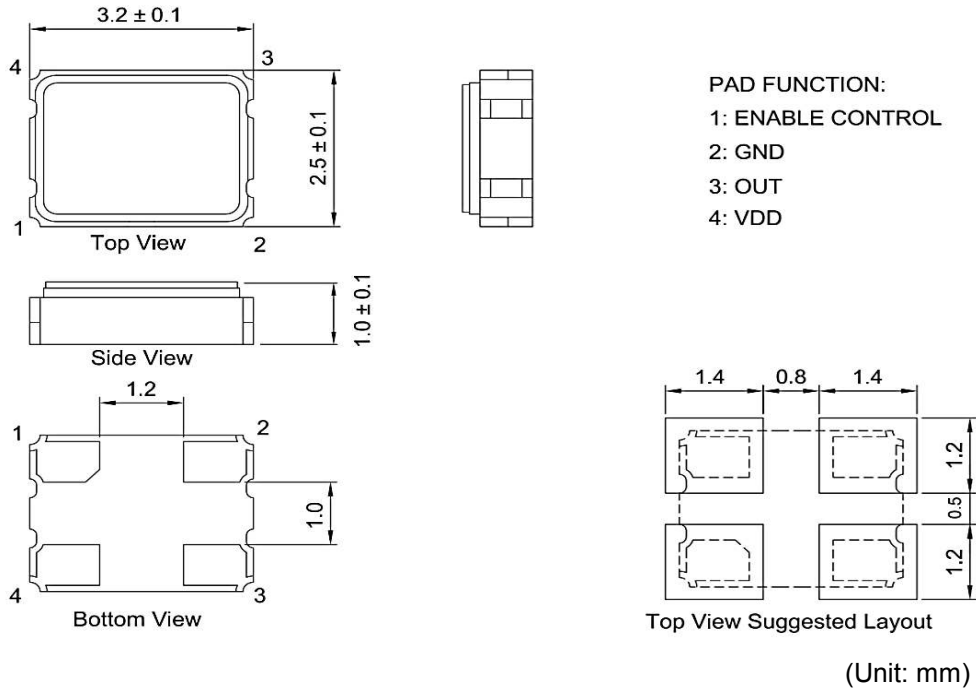

## Ordering Information

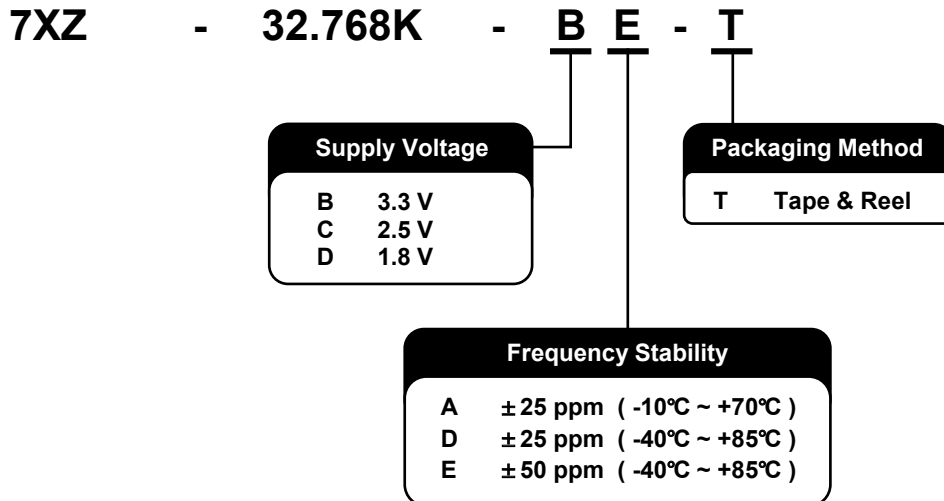

### Packing

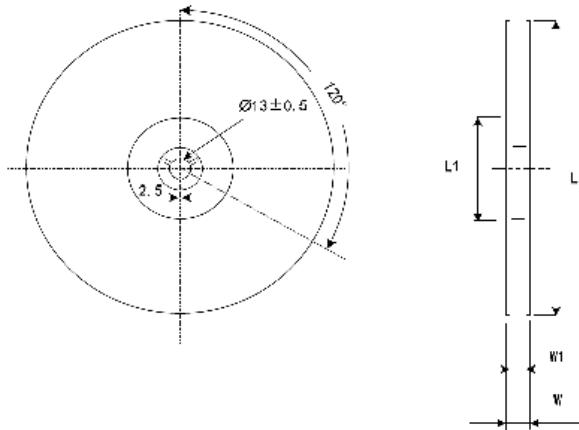
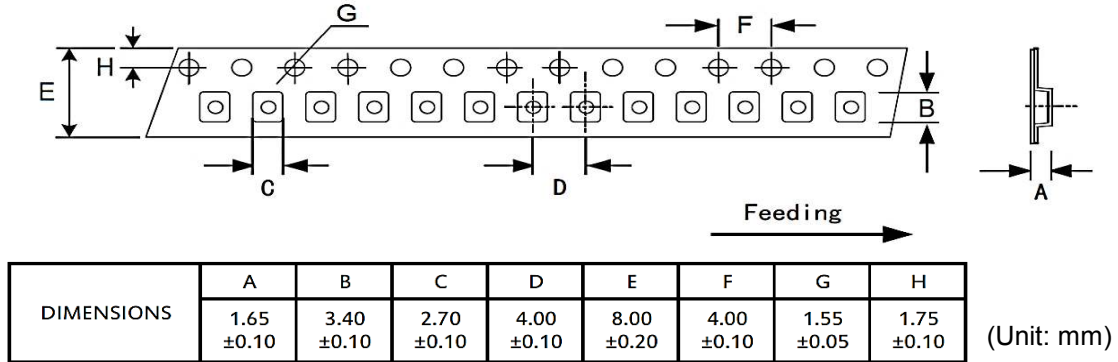

DIMENSIONS	L	L1	W	W1
	178 ±1.00	60.2 ±0.50	11.5 ±0.2	8 +1/-0

(Unit: mm)

### Reflow Profile

Solder melting point : 220°C ± 10°C, 60 sec. Min.

Peak temperature : 260°C ± 10°C, 10 sec. Min.

