

LOC	DIST	REVISIONS			
		REV	DATE	BY	APPV
AA	22	C1	REVISD PER ECO-09-025699	12DEC09	KK AEG
		D	ECO-11-021476	26OCT11	JJ MQW
		E	ECO-15-006810	29OCT2015	LL SH
		E1	REVISD PER ECO-21-000623	28JUL2020	IT SH

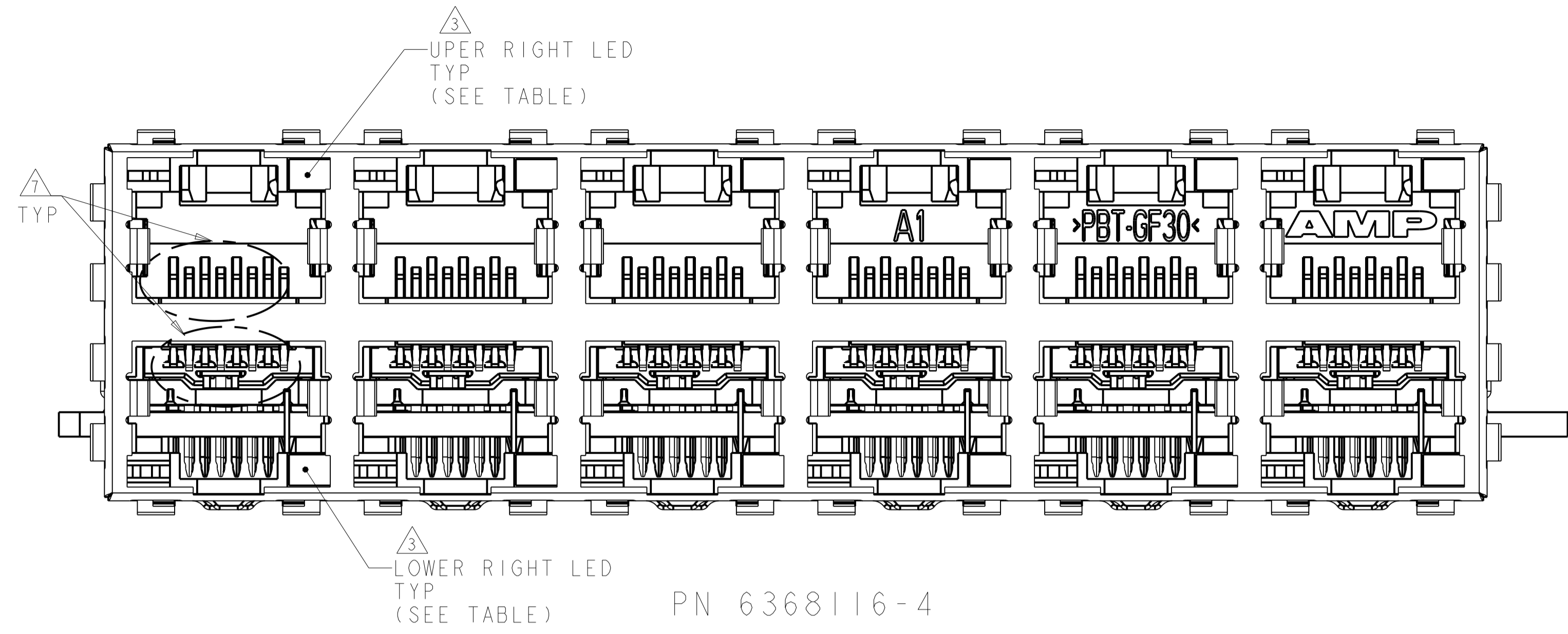

- MATERIAL:  
HOUSING:  
PBT POLYESTER, BLACK, UL 94V-0.  
  
TERMINALS:  
0.33 THICK PHOSPHOR BRONZE PLATED WITH 1.27µm MINIMUM THICK HARD GOLD IN LOCALIZED AREA AND 2µm MINIMUM THICK MATTE TIN IN ACTION PIN COMPLIANT PIN TERMINAL AREA OVER 1.27µm MINIMUM THICK NICKEL UNDERPLATE.  
  
SHIELD:  
0.25 THICK COPPER ALLOY PLATED WITH 1.27µm MINIMUM NICKEL.  
  
LIGHT EMITTING DIODE (LED):  
DIFFUSED EPOXY LENS, 0.51 CARBON STL WIREFRAME LEADS  
PREPLATED WITH 8.89 µm THICK TIN/COPPER OVER 2.03 µm THICK SILVER OVER 1.02 µm THICK COPPER OVER 3.56 µm THICK NICKEL OVER 1.02 µm THICK COPPER UNDERPLATE.  
  
LED ACTION PIN - COMPLIANT PIN CONTACTS 0.3 THICK BRASS PLATED WITH 2µm MINIMUM MATTE TIN OVER 1.27µm MINIMUM NICKEL UNDERPLATE.
  - JACK CAVITY CONFORMS TO FCC RULES AND REGULATIONS, PART 68 SUBPART F.
- ③ SUGGESTED OPERATING CURRENT FOR LEDS IS 20 mA
  - ④ DRILLED HOLE DIA = 1.02±.025.  
COPPER THICKNESS = 0.025-0.075.  
TIN THICKNESS = 0.008 MIN.
  - ⑤ DATUMS AND BASIC DIMENSIONS ESTABLISHED BY CUSTOMER
  - ⑥ DATE CODE LOCATED ON REAR OF PART APPROXIMATELY AS SHOWN
  - ⑦ CONTACTS ARE NOT INTENDED TO BE ALIGNED WITH EACH OTHER
  - ⑧ FOR THE PART NUMBER 6368116-4, CONTACT AREA LUBRICATED WITH BELLCORE APPROVED LUBRICANT. TECHNICAL REFERENCE GR-1217-CORE, ISSUE 1, NOVEMBER 1995.
  - ⑨ OBSOLETE PARTS: OBSOLETE CIS STREAMLINING PER D.RENAUD/D.SINISI

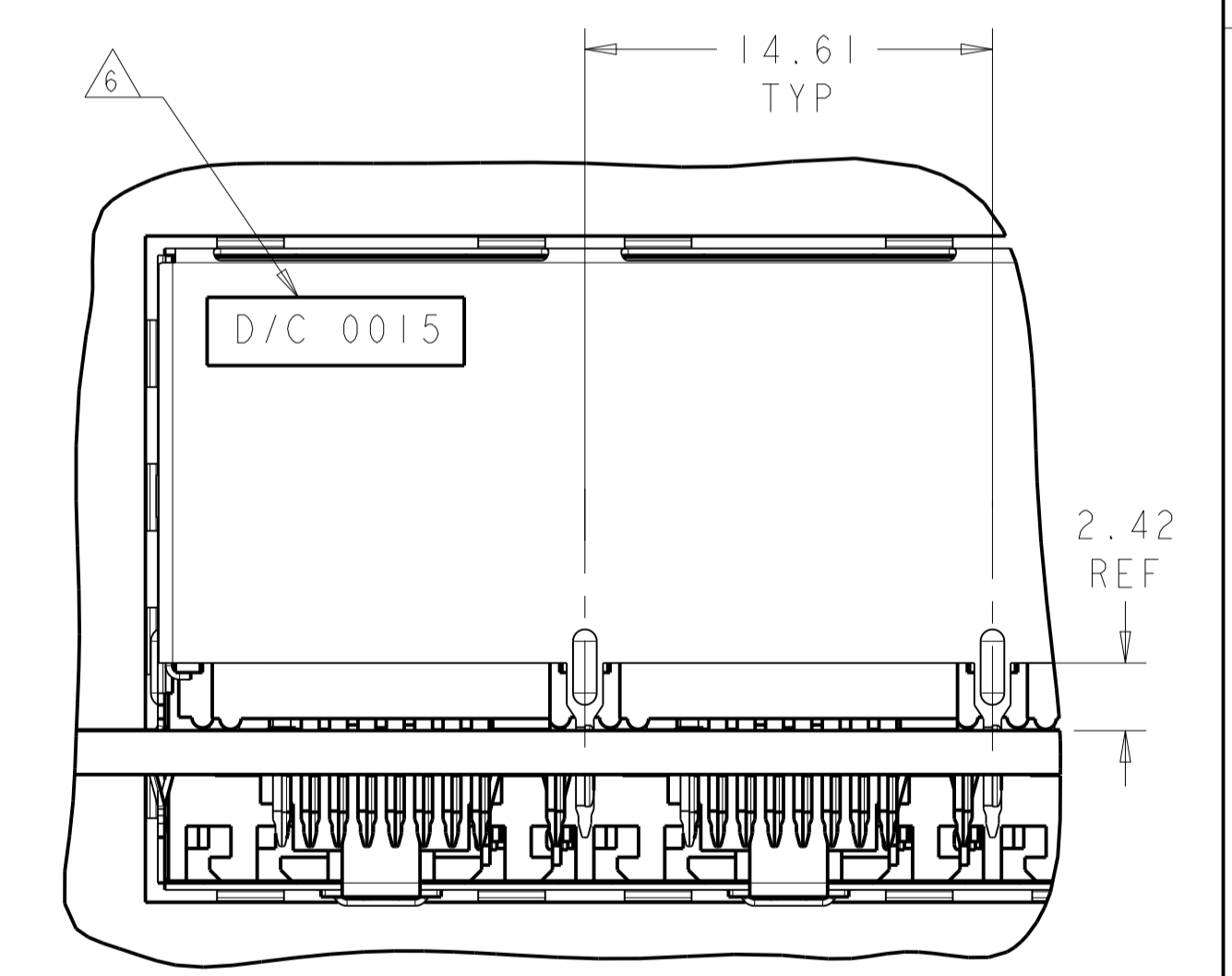
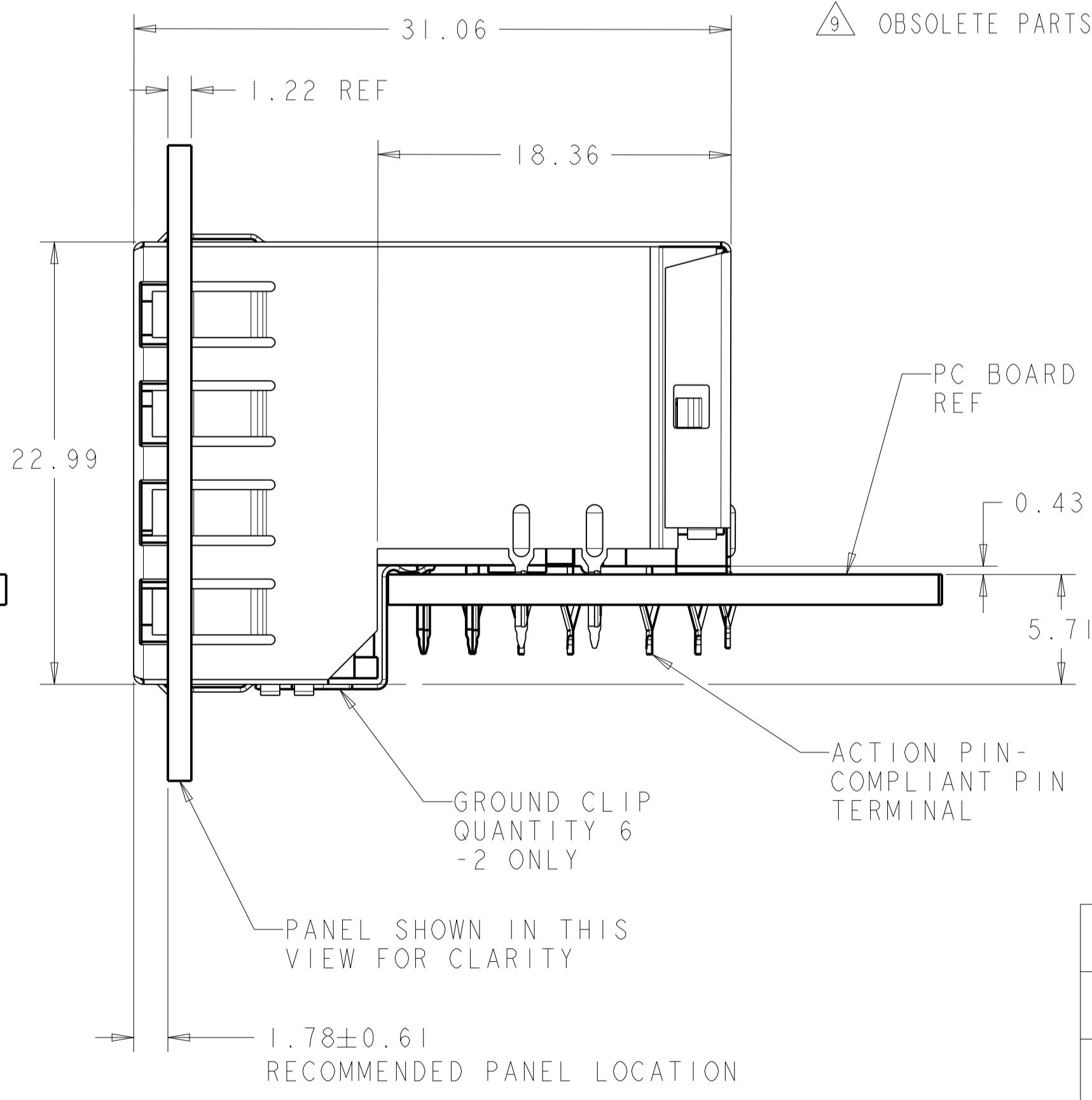
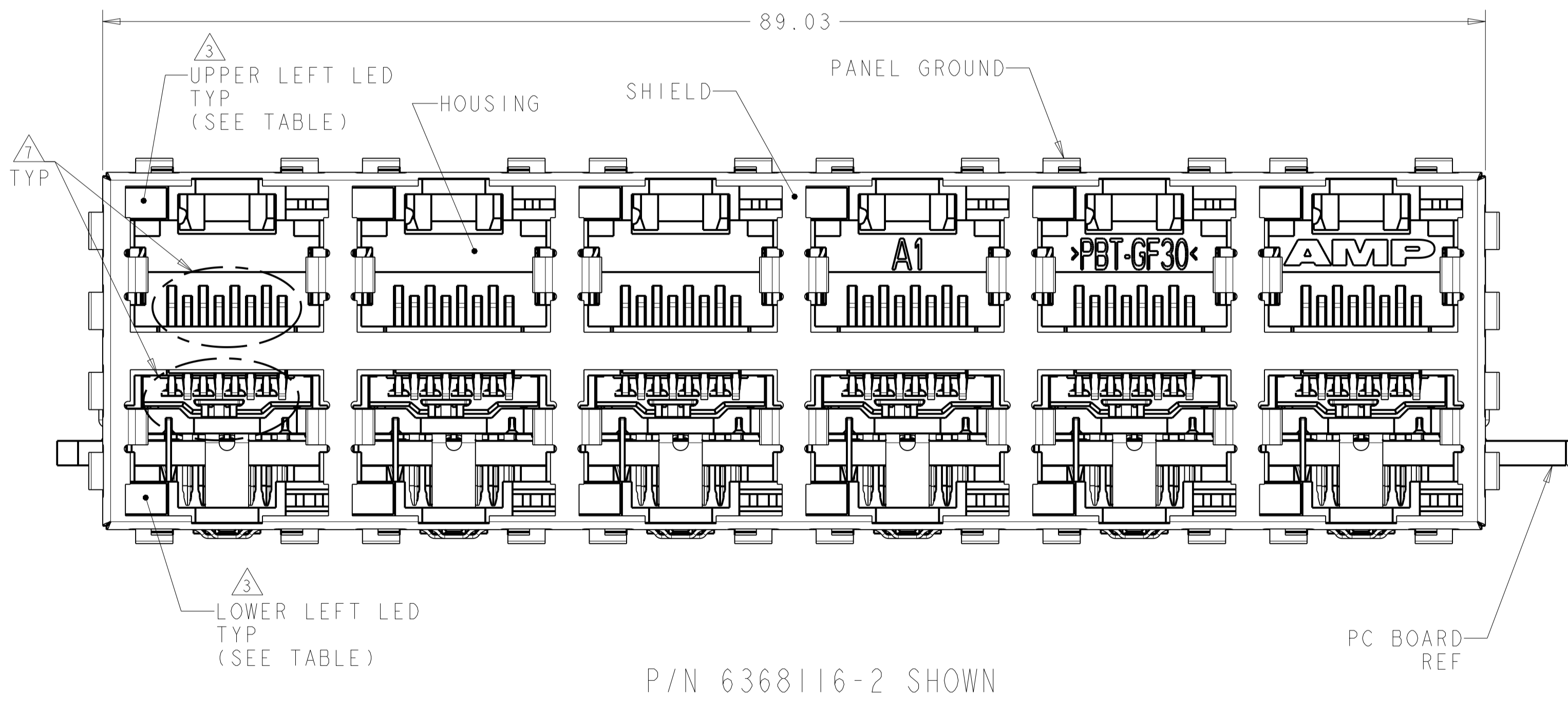

PARTIAL BACK VIEW

LED COLOR	DESCRIPTION	PART NUMBER
GREEN	RIGHT HAND LEDS ONLY	6368116-4 ⑧
YELLOW/GREEN	LEFT HAND LEDS ONLY	6368116-3
GREEN	LEFT HAND LEDS WITH GROUND CLIPS	6368116-2
GREEN	LEFT HAND LEDS ONLY	6368116-1

THIS DRAWING IS A CONTROLLED DOCUMENT.

STE TE Connectivity

NAME: OFFSET STACKED MOD JACK ASSEMBLY 2 X 6, 8 POSITION, RJ45, SHIELDED, PANEL GROUND, WITH LEFT LED, CAT 5

SIZE: 108-1854 APPLICATION SPEC

SCALE: 4:1 SHEET 1 OF 3 REV E1

LOC	DIST	REV	DATE	BY	APPV
AA	22				
		REVISIONS			
		DESCRIPTION	DATE	BY	APPV
		SEE SHEET 1			

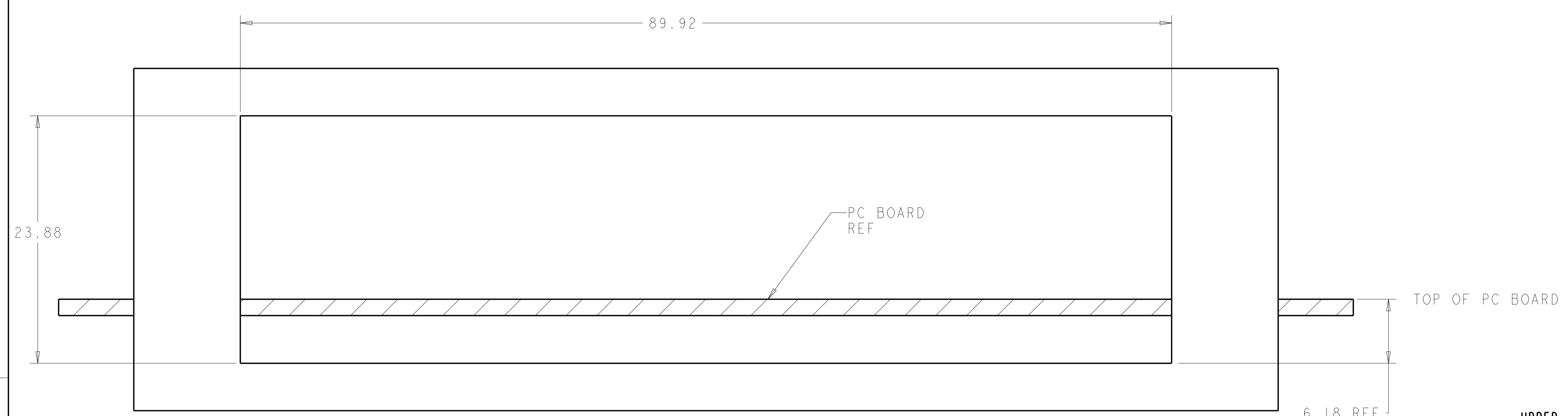

RECOMMENDED PANEL CUT-OUT

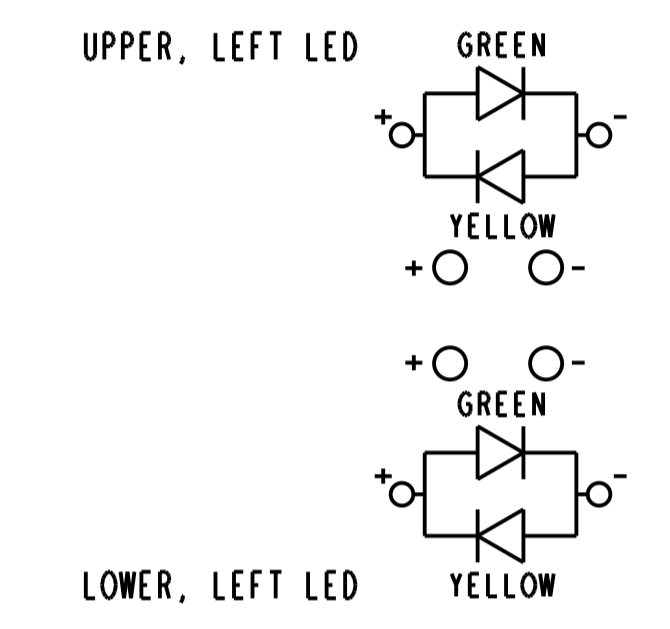
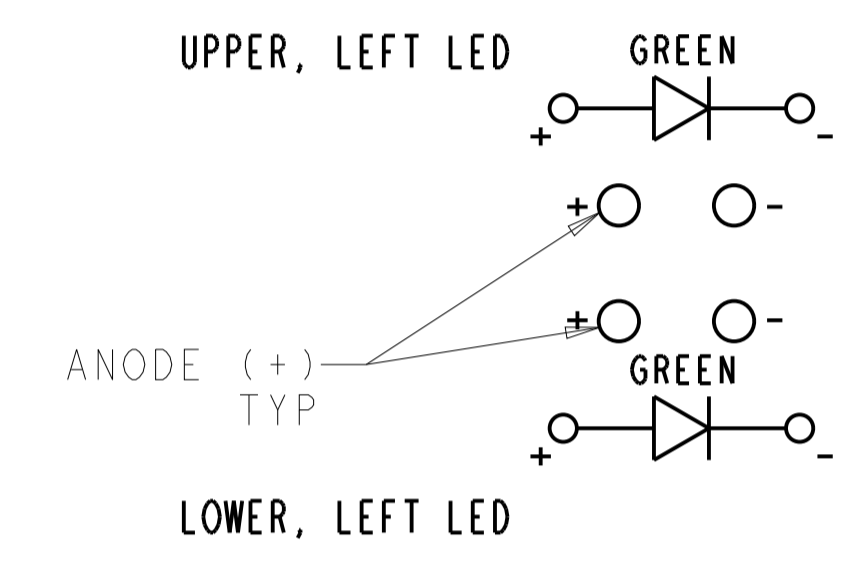
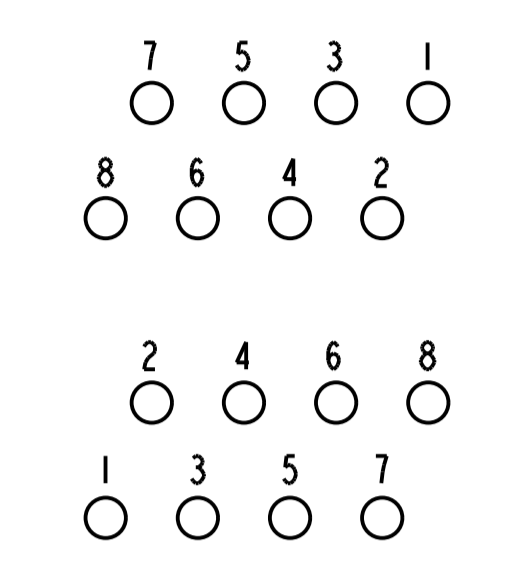

6368116-1, -2  
LED SCHEMATIC

6368116-3  
LED SCHEMATIC

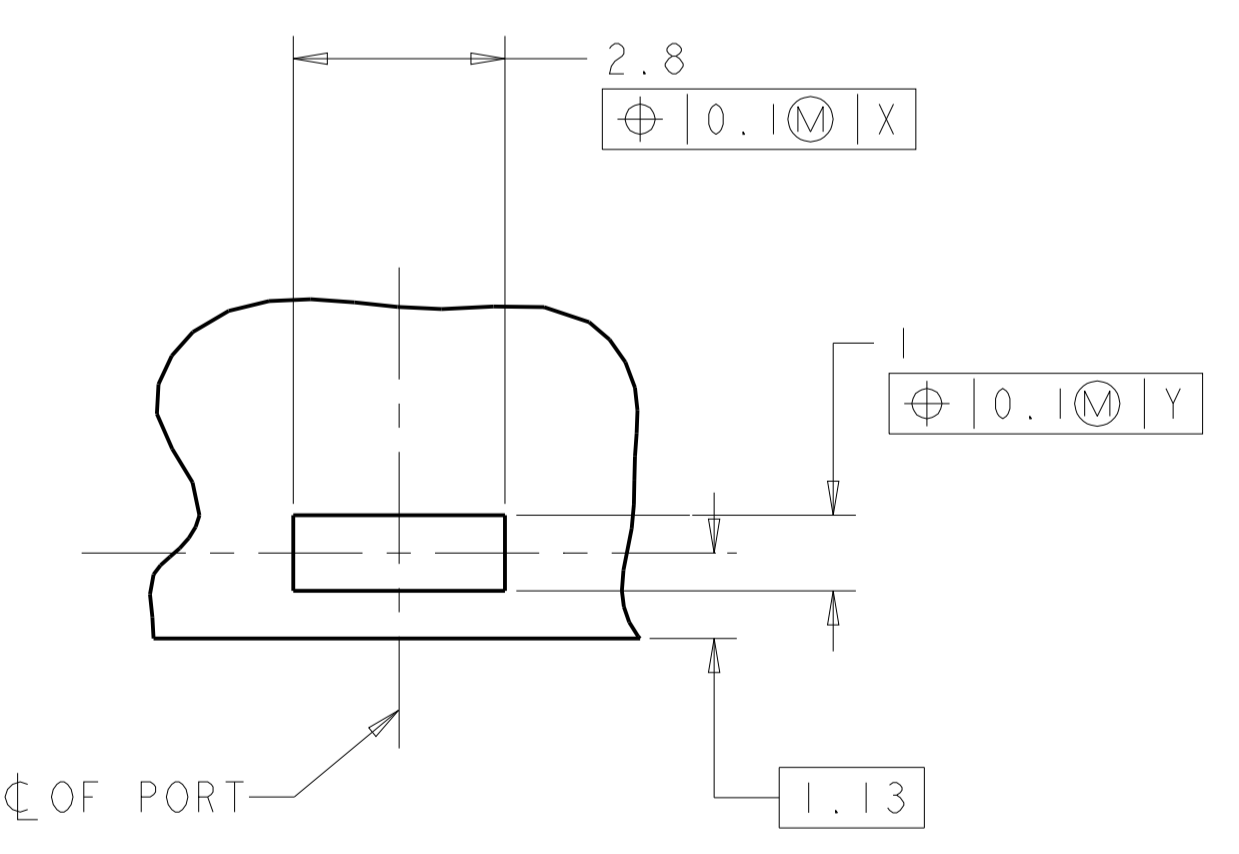
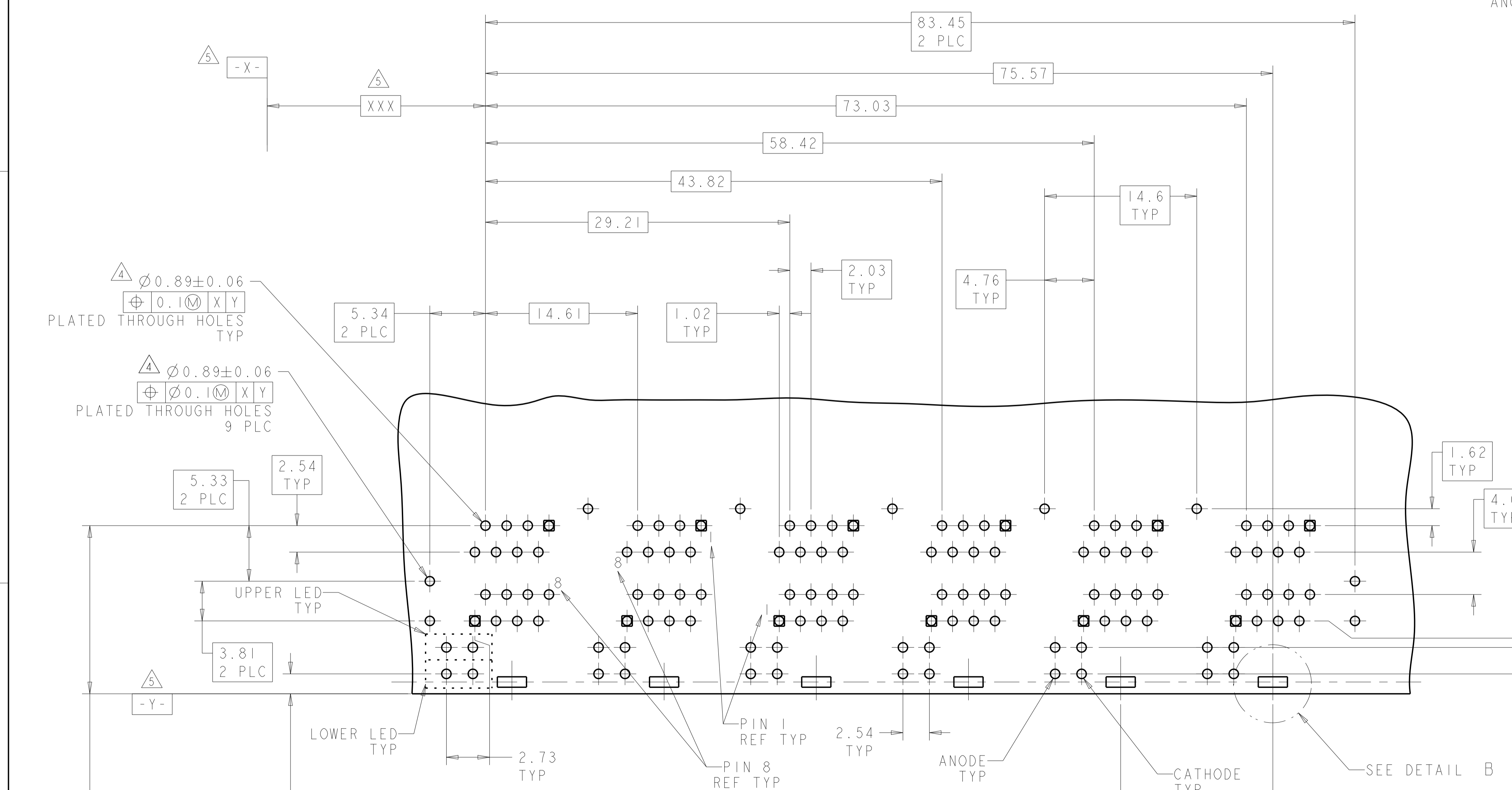

DETAIL B  
 THESE PLATED PADS REQUIRED FOR 6368116-2  
 PRODUCT WITH GROUNDING CLIPS  
 SCALE 10:1  
 6 PLACES

PART WITH GROUNDING CLIPS = 1.65  
 PART WITHOUT GROUNDING CLIPS = 1.91

PN 6368116-1,2,3  
 PC BOARD LAYOUT  
 (COMPONENT SIDE)

15.88 WITH GROUNDING CLIPS  
 16.13 WITHOUT GROUNDING CLIPS

THIS DRAWING IS A CONTROLLED DOCUMENT.		OWN A. FERNANDEZ 27JUL2005	NAME OFFSET STACKED MOD JACK ASSEMBLY
DIMENSIONS: mm		CHK J. WESTMAN 27JUL2005	PRODUCT SPEC 2 X 6, 8 POSITION, RJ45, SHIELDED,
TOLERANCES UNLESS OTHERWISE SPECIFIED: 0 PLC $\pm 0.13$ 1 PLC $\pm 0.13$ 2 PLC $\pm 0.13$ 3 PLC $\pm 0.13$ 4 PLC $\pm 0.13$ ANGLES $\pm 0.13$		APPV S. ELICKINGER 27JUL2005	PANEL GROUND, WITH LEFT LED, CAT 5
MATERIAL SEE NOTE 1	FINISH SEE NOTE 1	PRODUCT SPEC 108-1854	SIZE 114-2160
CUSTOMER DRAWING		WEIGHT -	SCALE 4:1
SCALE 4:1		REV E	SHEET 2 OF 3

LOC	DIST	REVISIONS					
		P	LTN	DESCRIPTION	DATE	DMN	APVD
AA	22	-	-	SEE SHEET 1	-	-	-

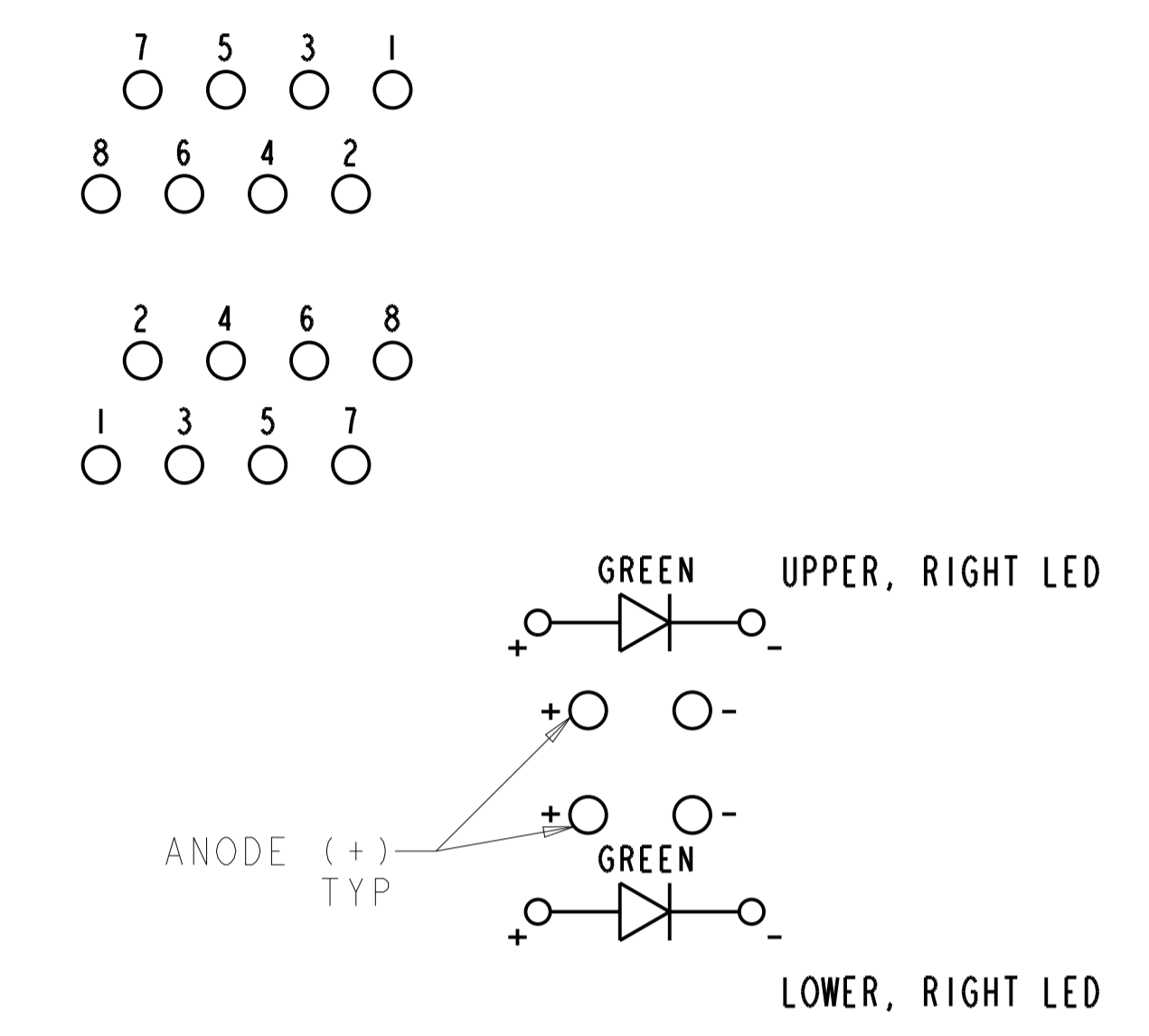
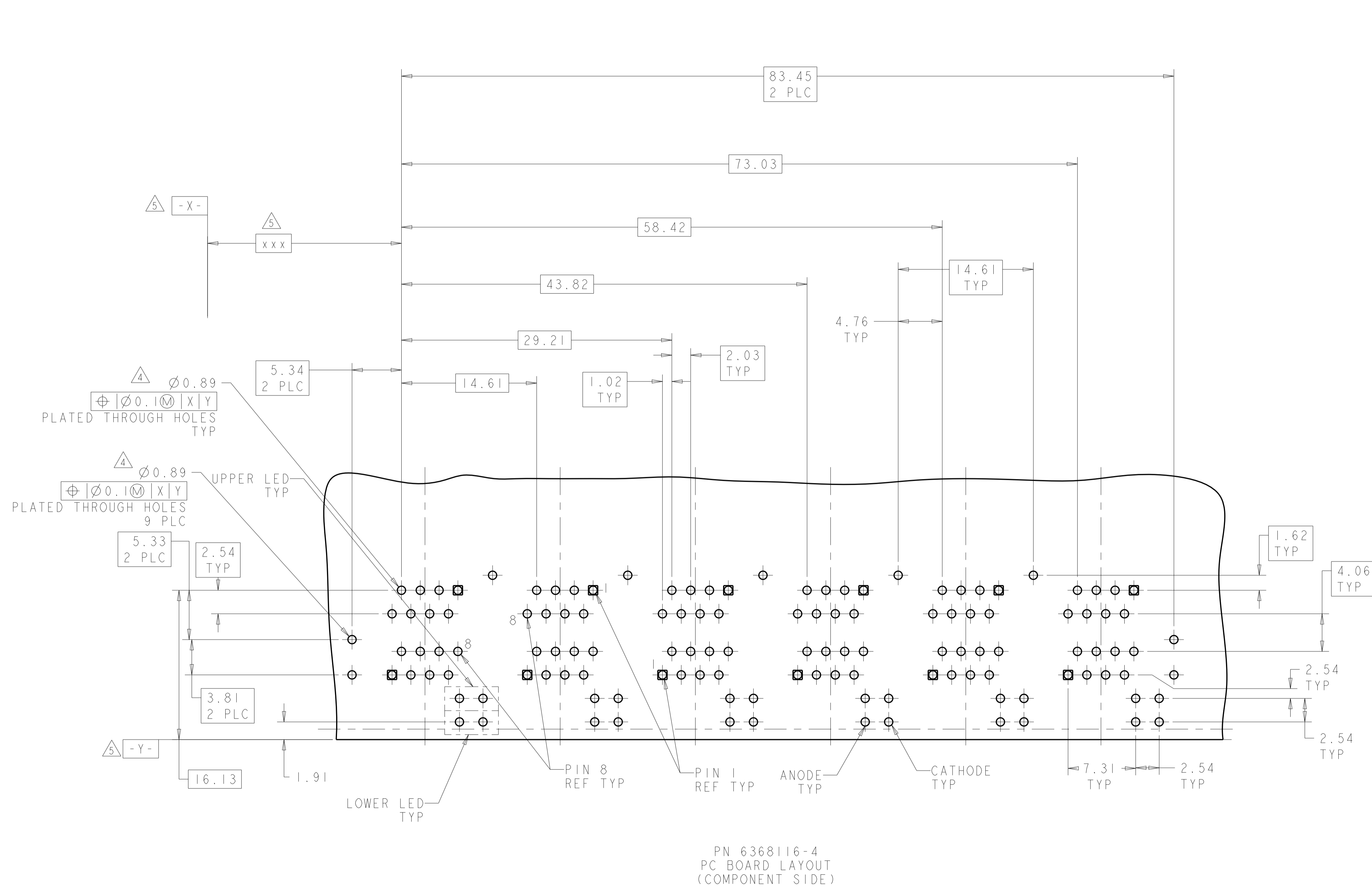

PN 6368116-4  
 PC BOARD LAYOUT  
 (COMPONENT SIDE)

THIS DRAWING IS A CONTROLLED DOCUMENT.		DMN: A.FERNANDEZ 27JUL2005	TE Connectivity
DIMENSIONS: mm		CHK: J.WESTMAN 27JUL2005	
TOLERANCES UNLESS OTHERWISE SPECIFIED:		APVD: S.FLICKINGER 27JUL2005	NAME: OFFSET STACKED MOD JACK ASSEMBLY 2 X 6, 8 POSITION, RJ45, SHIELDED, PANEL GROUND, WITH LEFT LED, CAT 5
0 PLC ± 1 PLC ±0.13 2 PLC ± 3 PLC ± 4 PLC ± ANGLES ±1°		PRODUCT SPEC: 108-1854 APPLICATION SPEC: 114-2160 WEIGHT: -	
MATERIAL: SEE NOTE 1	FINISH: SEE NOTE 1	CUSTOMER DRAWING	SIZE: A100779 CAGE CODE: 6368116 SCALE: 4:1 SHEET 3 OF 3 REV: E1