

BASE CAGE DETAILS

747540220

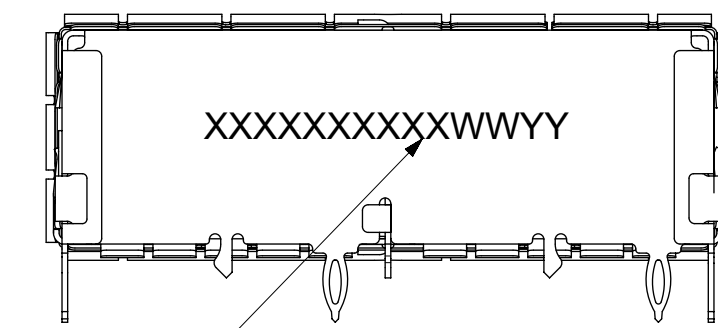
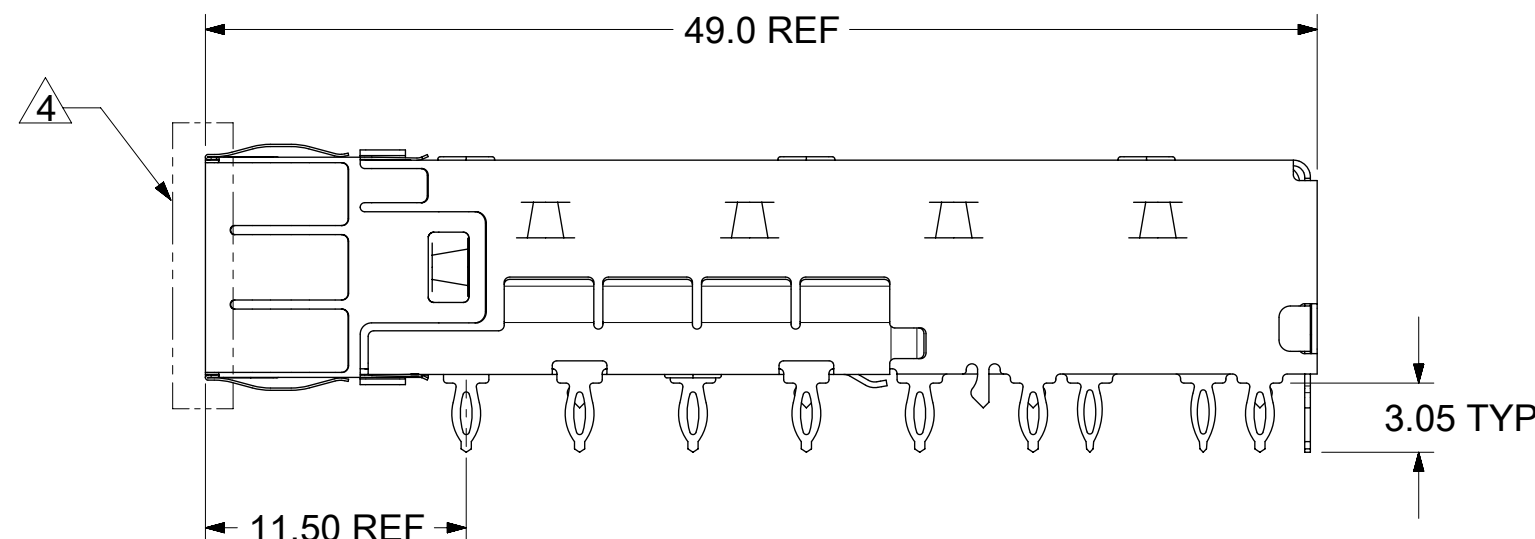
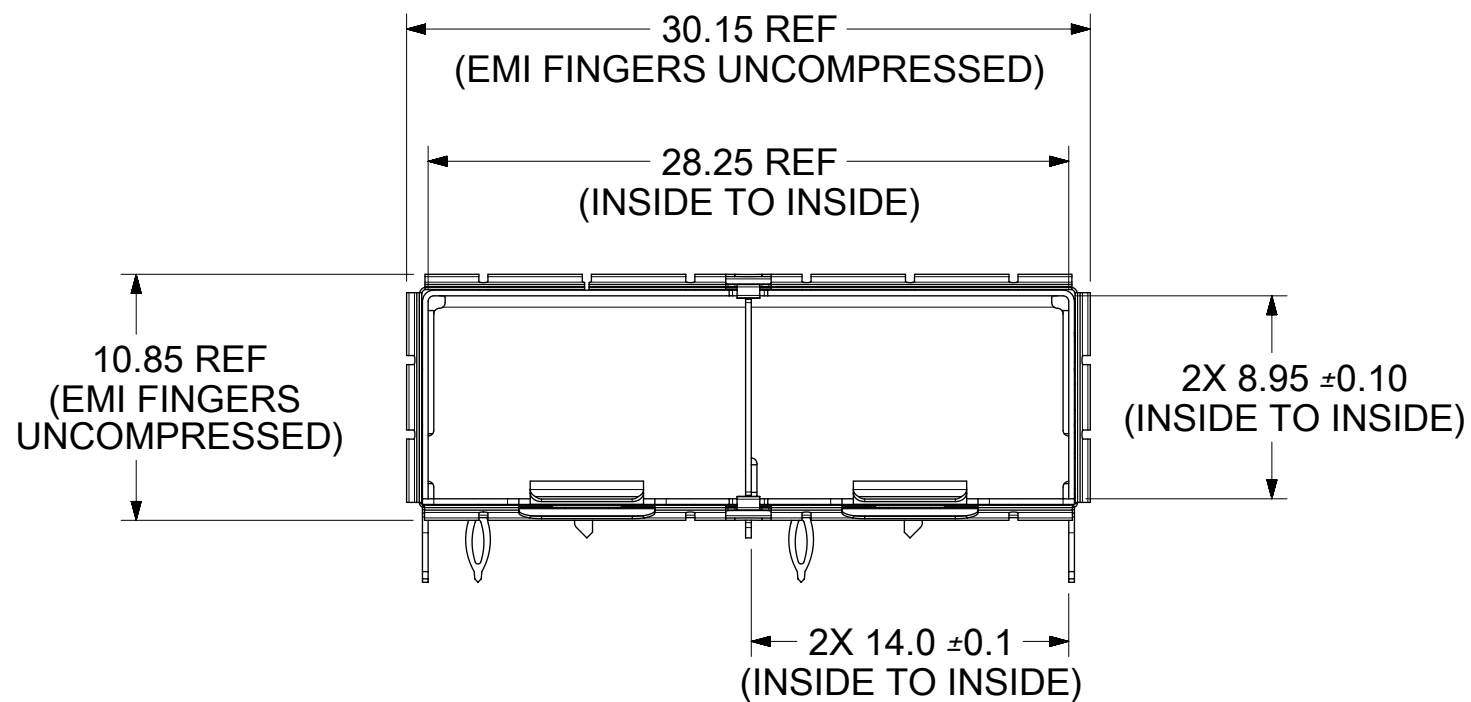
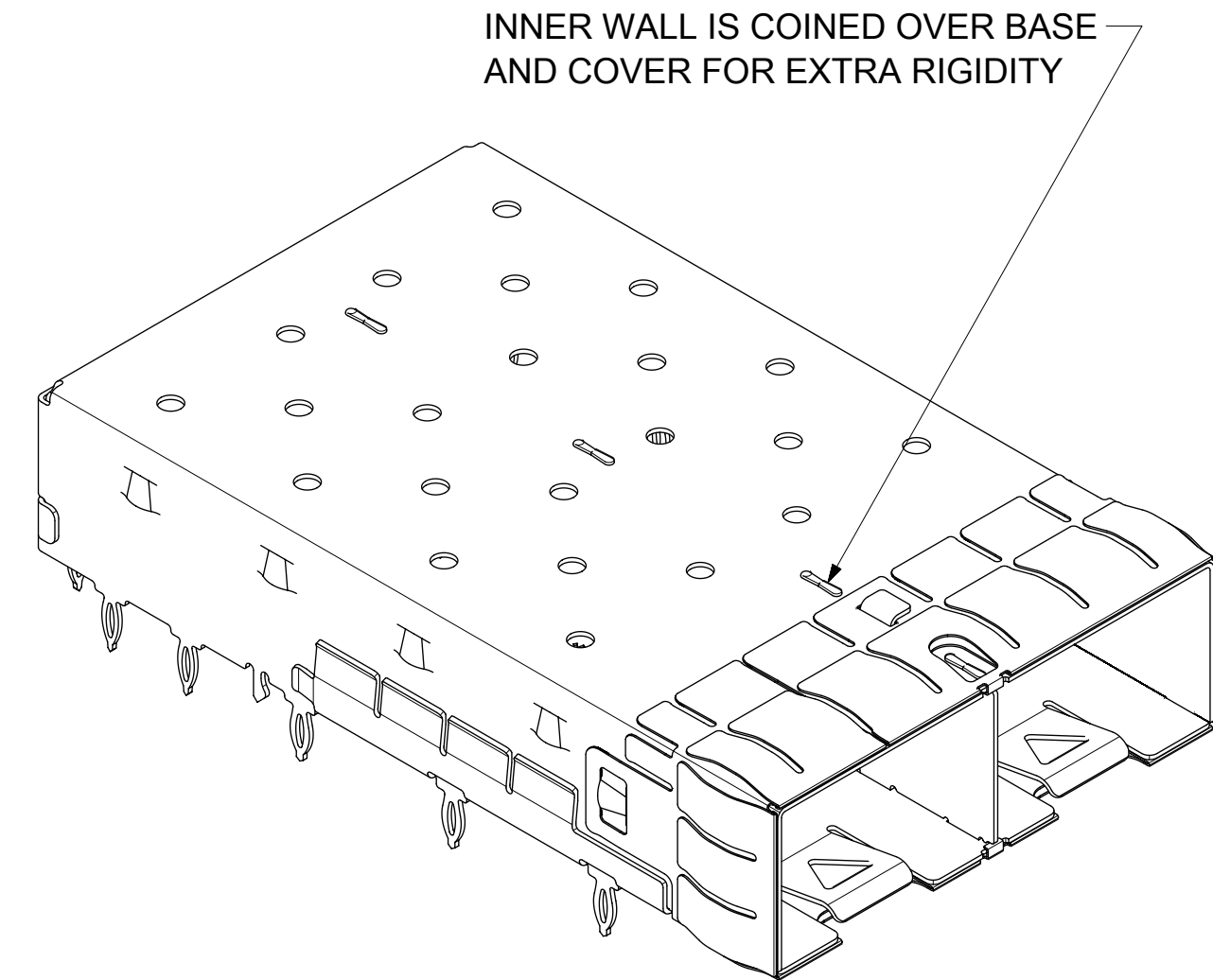
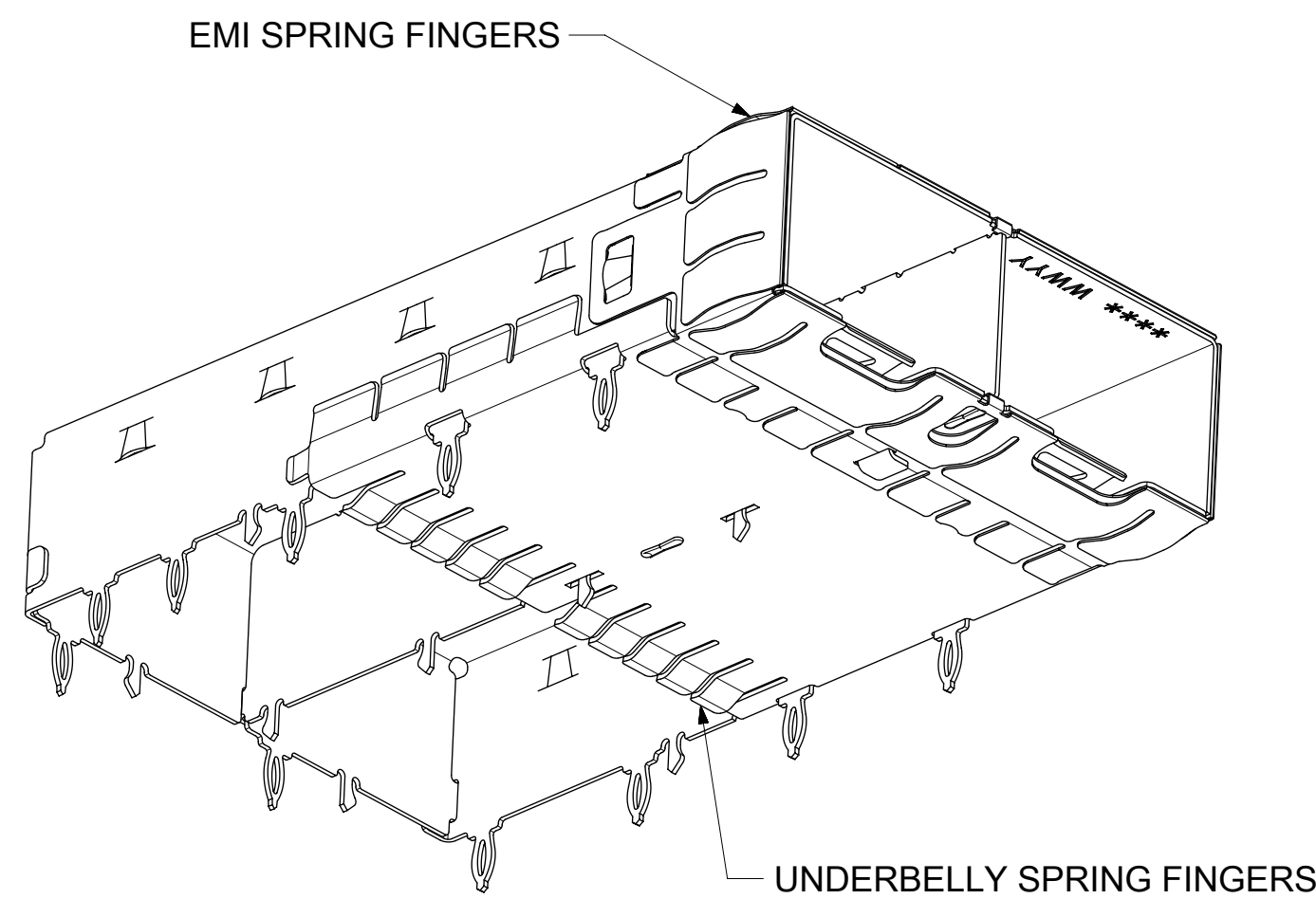
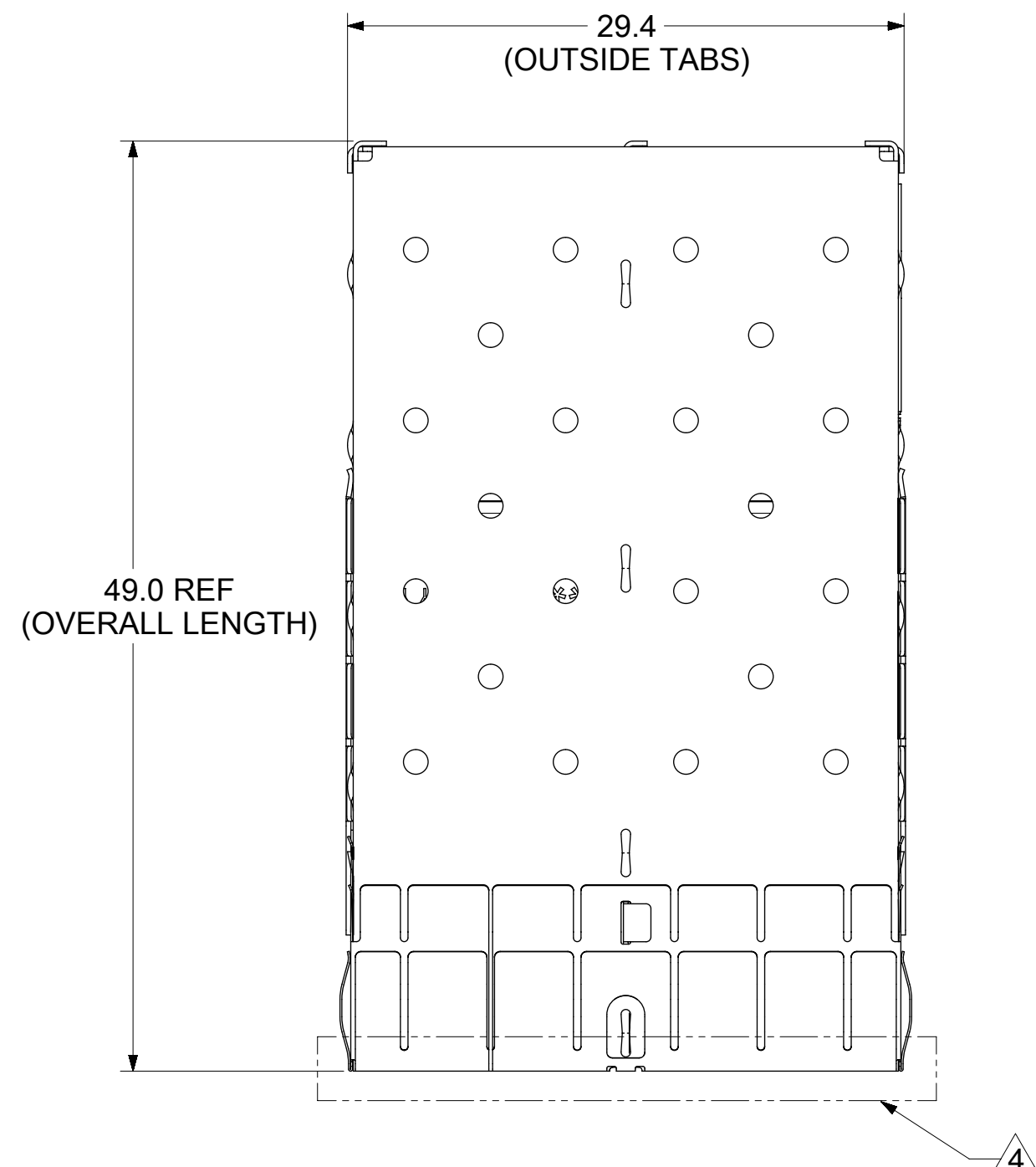

PN/DATE CODE TO BE PRINTED ON THE BACK OF COMPLETED CAGE ASSEMBLY APPROXIMATELY AS SHOWN. FOR 74754 SERIES CAGE (747540247 NO NEED PRINTED)

WEEK/YEAR DATE CODE TABLE

WW	WEEK OF THE YEAR 01 THRU 52 (EXAMPLE:01= FIRST WEEK OF YEAR 52=LAST WEEK OF YEAR)
YY	16, 17, 18 ETC. EXAMPLE: YEAR 2016 = 16

NOTES:

- MATERIAL:
CAGE: 0.25mm THICK COPPER ALLOY, NICKEL PLATED.
SPRING FINGERS: 0.10mm THICK COPPER ALLOY, NICKEL PLATED.
HEATSINK: ALUMINUM, NICKEL PLATED.
HEATSINK SPRING CLIP: STAINLESS STEEL.
- PRESS FIT LEGS 3.05mm LONG
- PORTS ARE DESIGNED FOR SFP+ TRANSCEIVERS AND ARE COMPATIBLE WITH SFP TRANSCEIVERS. THE TOP SURFACE OF THE MODULE MUST BE FLAT (NO PRODUCT LABEL RECESS) AND THERMALLY CONDUCTIVE TO FUNCTION OPTIMALLY.
- WELD SPOT MAY SHOW SLIGHT MATERIAL DISCOLORATION.
- NO RoHS EXEMPTIONS.
- CUSTOM HEATSINKS AVAILABLE UPON REQUEST.

QUALITY SYMBOLS	THIS DRAWING CONTAINS INFORMATION THAT IS PROPRIETARY TO MOLEX ELECTRONIC TECHNOLOGIES, LLC AND SHOULD NOT BE USED WITHOUT WRITTEN PERMISSION		DIMENSION UNITS	SCALE	molex
▽ = 0	SEE REVISION TABLE EC NO: 111626 DRWN: SJLG CHKD: DSUN15 REV APPR: RCHEN08 2016/12/15 2016/12/21 2016/12/21	GENERAL TOLERANCES (UNLESS SPECIFIED)	MM	3:1	
▽ = 0		ANGULAR TOL ± 1.0 °	DRWN BY	DATE	
▽ = 0		4 PLACES ±	MKEMPEGOWDA	2016/04/13	
▽ = 0		3 PLACES ±	CHKD BY	DATE	
▽ = 0		2 PLACES ± 0.13	DSUN15	2016/07/31	
▽ = 0		1 PLACE ± 0.25	APPR BY	DATE	
▽ = 0	0 PLACES ±	RCHEN08	2016/08/04	PRODUCT CUSTOMER DRAWING	
□ = 0	DRAFT WHERE APPLICABLE MUST REMAIN WITHIN DIMENSIONS	DRAWING SIZE	THIRD ANGLE PROJECTION	SERIES	MATERIAL NUMBER
▽ = 0		C		111112	SEE SHEET 3
				DOCUMENT NUMBER	DOC TYPE
				1111122220	PSD
				DOC PART	SHEET NUMBER
				ASY	1 OF 7

CAGE ASSEMBLY OPTIONS

OPEN TOP
1111120220
SHOWN
(APPLIES TO ALL
OPEN TOP CAGES)

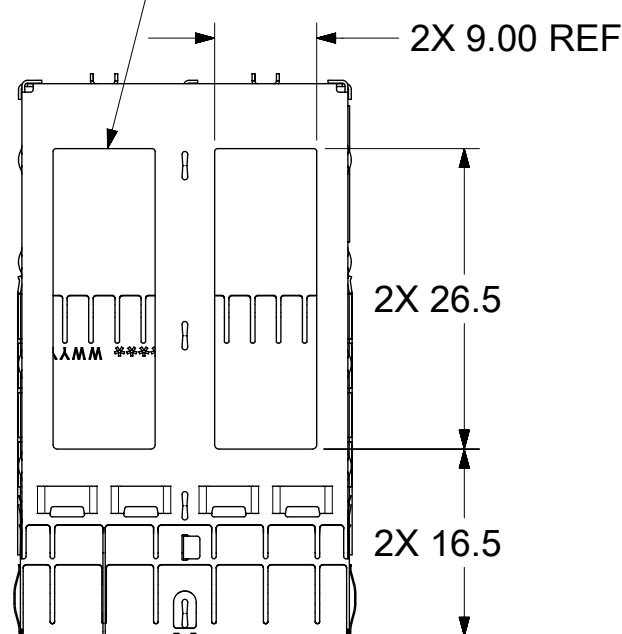

HEATSINK OPTIONS
(2 PLC)
CUSTOM

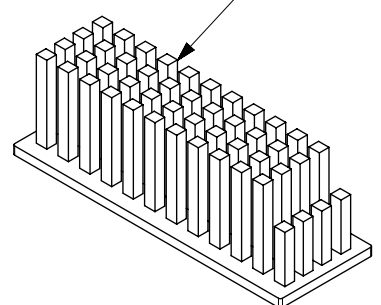

OVERALL HEATSINK HEIGHT

STYLE	DIM 'A'	DIM 'B'
CUSTOM	20.4	16.7

HEATSINK OPTIONS
(2 PLC)

PIN FIELD NETWORKING
PIN FIELD SAN
PIN FIELD PCI

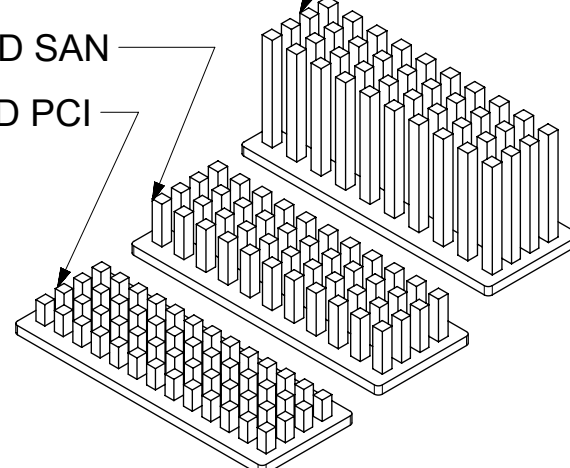

OVERALL HEATSINK HEIGHT

APPLICATION	STYLE	DIM 'A'
PCI	PIN FIELD	14.3
SAN	PIN FIELD	16.6
NETWORKING	PIN FIELD	23.6

NOTE: PCI - 13 ROWS
SAN - 11 ROWS
NETWORKING - 10 ROWS

HEATSINK OPTIONS
(2 PLC)

LATERAL FIN NETWORKING
LATERAL FIN SAN
LATERAL FIN PCI

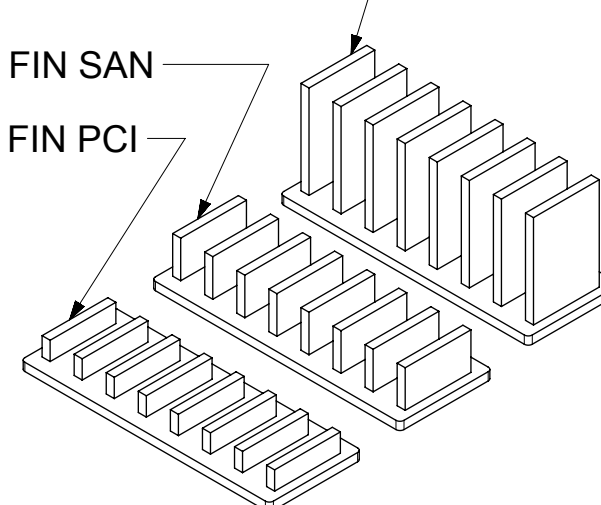

OVERALL HEATSINK HEIGHT

APPLICATION	STYLE	DIM 'A'
PCI	LATERAL FIELD	14.3
SAN	LATERAL FIELD	16.6
NETWORKING	LATERAL FIELD	23.6

HEATSINK OPTIONS
(2 PLC)

WIDE GAP NETWORKING
WIDE GAP SAN
WIDE GAP PCI

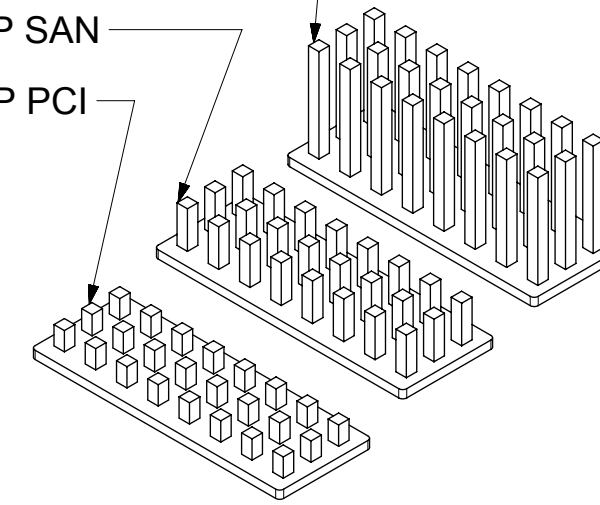

OVERALL HEATSINK HEIGHT

APPLICATION	STYLE	DIM 'A'
PCI	WIDE GAP PIN	14.3
SAN	WIDE GAP PIN	16.6
NETWORKING	WIDE GAP PIN	23.6

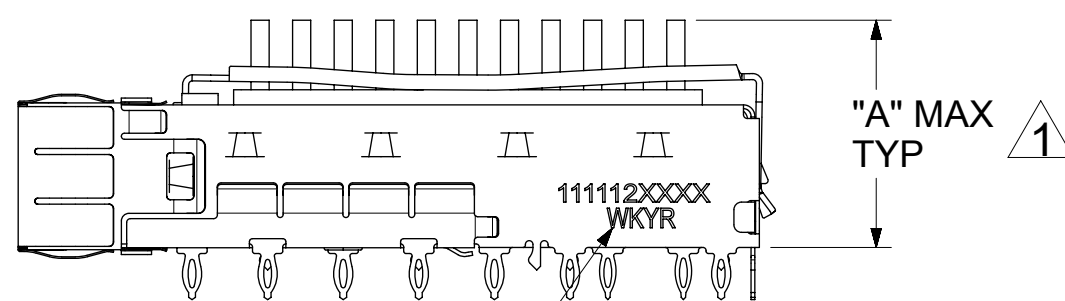
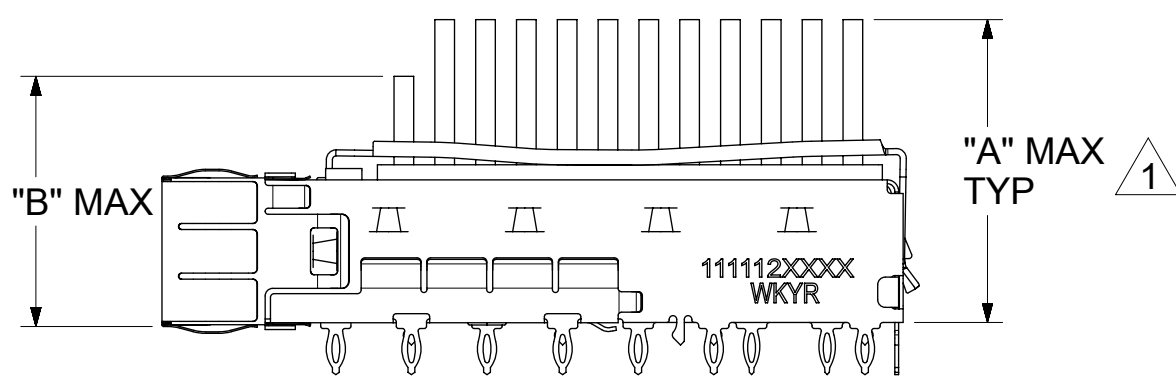

PN/DATE CODE TO BE PRINTED ON THE SIDE OF
COMPLETED CAGE ASSEMBLY APPROXIMATELY AS SHOWN.
FOR 111112 SERIES CAGES

WEEK/YEAR DATE CODE TABLE	
WW	01 THRU 52 OR 53 EXAMPLE: 01 = FIRST WEEK OF YEAR 52 = LAST WEEK OF YEAR
YY	16, 17, 18 ETC. EXAMPLE: YEAR 2016 = 16

1 WITH MODULE INSERTED, DIMENSION MAY BE LESS DUE TO MODULE AND HEATSINK VARIATIONS

REAR LEG OPTIONS
(PER PORT)

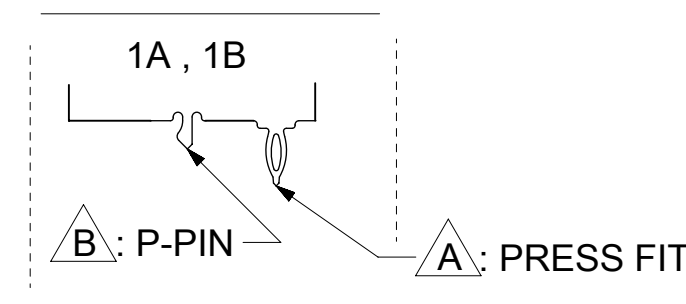

HEATSINK OPTIONS
CUSTOM FIN

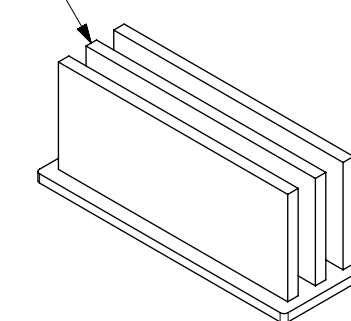

OVERALL HEATSINK HEIGHT

APPLICATION	DIM 'A'
CUSTOM	23.6

QUALITY SYMBOLS	THIS DRAWING CONTAINS INFORMATION THAT IS PROPRIETARY TO MOLEX ELECTRONIC TECHNOLOGIES, LLC AND SHOULD NOT BE USED WITHOUT WRITTEN PERMISSION		DIMENSION UNITS		SCALE
			MM	1.5:1	
SEE REVISION TABLE	EC NO: 111626	2016/12/15	DRWN BY	DATE	
	DRWN: SJLG	2016/12/21	MKEMPEGOWDA	2016/04/13	
	CHKD: DSUN15	2016/12/21	CHKD BY	DATE	
	REV APPR: RCHEN08		DSUN15	2016/07/31	
			APPR BY	DATE	
			RCHEN08	2016/08/04	
			DRAWING SIZE	THIRD ANGLE PROJECTION	
			C		
DRAFT WHERE APPLICABLE MUST REMAIN WITHIN DIMENSIONS					
			SERIES		MATERIAL NUMBER
			111112		SEE SHEET 3
			DOCUMENT NUMBER		DOC TYPE
			1111122220		PSD
			DOC PART		SHEET NUMBER
			ASY		2 OF 7

molex

SFP+ 1X2 CAGE, 3.05 MM
PRESS FIT, HEAT SINK, EMI SPRING FINGERS

PRODUCT CUSTOMER DRAWING

SERIES	MATERIAL NUMBER	CUSTOMER
111112	SEE SHEET 3	
DOCUMENT NUMBER	DOC TYPE	DOC PART
1111122220	PSD	ASY
		SHEET NUMBER
		2 OF 7

PART NUMBER SELECTION

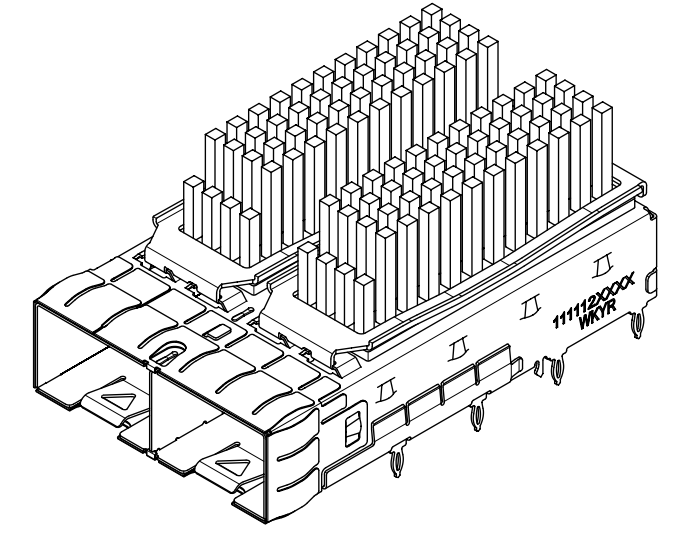
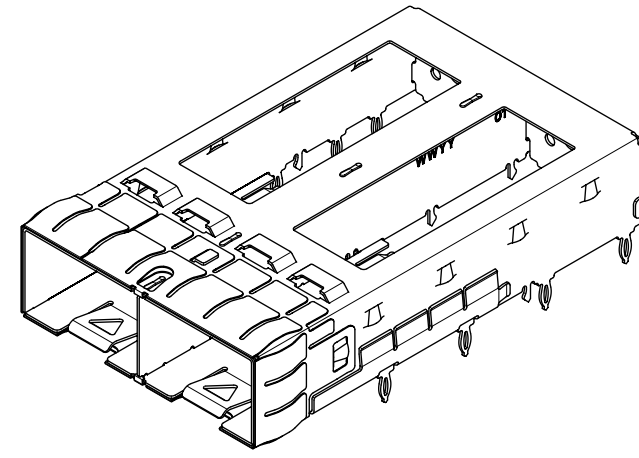
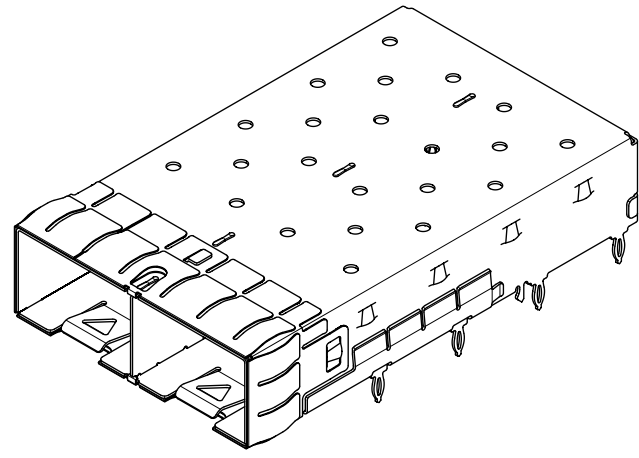

SFP+ CLOSED TOP BASE CAGE	
PART NO.	DESCRIPTION
747540220	SFP FOOTPRINT (STD B TO B), 5 WELD POINTS
747540222	SFP FOOTPRINT (STD B TO B), 16 WELD POINTS
747540247	SAME AS ABOVE BUT NO PN/DATE CODE PRINTED

SFP+ OPEN TOP BASE CAGE FOR HEATSINK	
PART NO.	
	1111120220

SFP+ CUSTOM HEATSINK OPTION	
PART NO.	
	1111120226

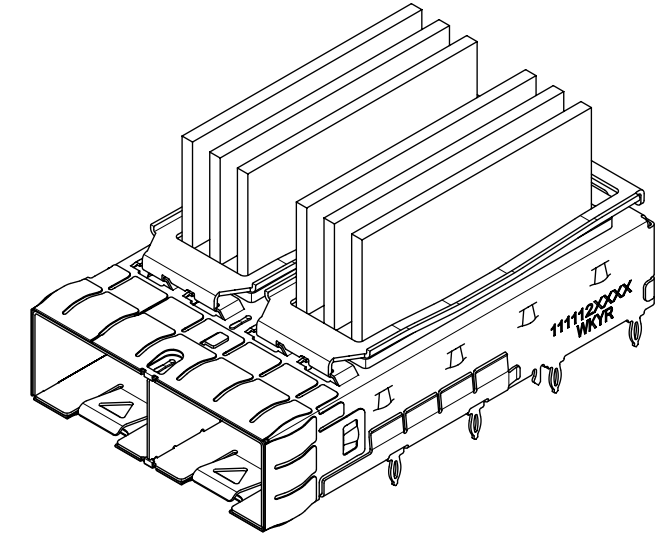
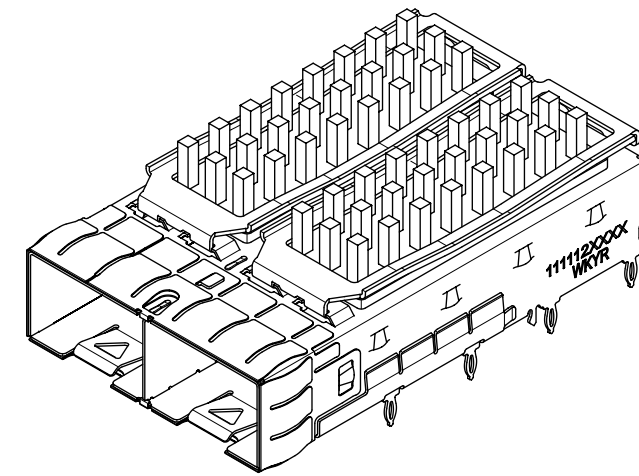
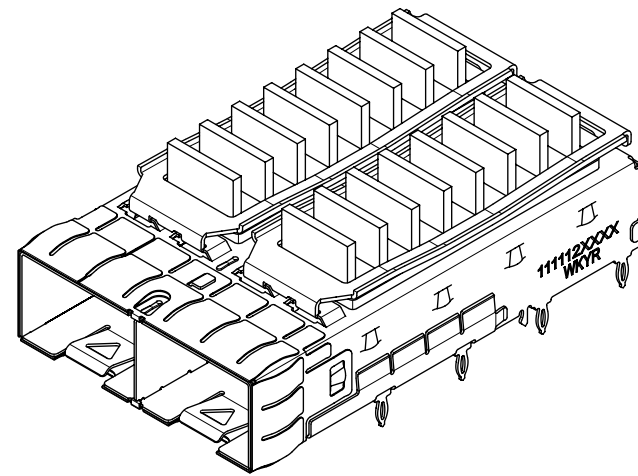
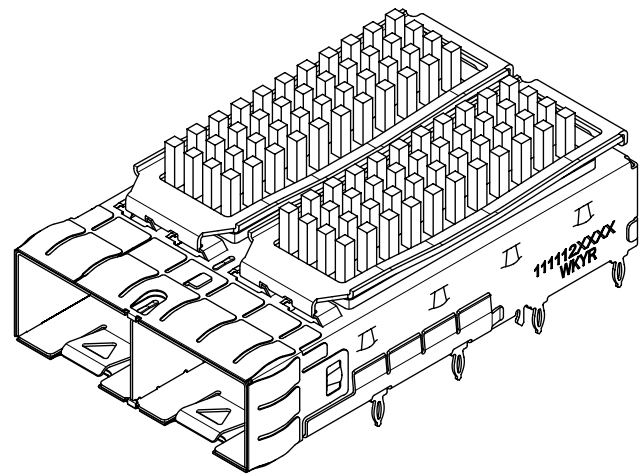

SFP+ PIN FIELD HEATSINK OPTION	
PART NO.	APPLICATION
1111121220	PCI
1111122220	SAN
1111123220	NETWORKING

SFP+ LATERAL FIN HEATSINK OPTION	
PART NO.	APPLICATION
1111124220	PCI
1111125220	SAN
1111126220	NETWORKING

SFP+ LATERAL FIN HEATSINK OPTION	
PART NO.	APPLICATION
1111127220	PCI
1111128220	SAN
1111129220	NETWORKING

SFP+ CUSTOM FIN HEATSINK OPTION	
PART NO.	
	1111126221

NOTE: PCI - 13 ROWS
 SAN - 11 ROWS
 NETWORKING - 10 ROWS

QUALITY SYMBOLS ▽ = 0 ▽ = 0 ▽ = 0 ▽ = 0 ▽ = 0 ▽ = 0 ▽ = 0 ▽ = 0 ▽ = 0 ▽ = 0	THIS DRAWING CONTAINS INFORMATION THAT IS PROPRIETARY TO MOLEX ELECTRONIC TECHNOLOGIES, LLC AND SHOULD NOT BE USED WITHOUT WRITTEN PERMISSION										
	SEE REVISION TABLE EC NO: 111626 DRWN: SJLG CHKD: DSUN15 REV: APPR: RCHEN08		2016/12/15 2016/12/21 2016/12/21		GENERAL TOLERANCES (UNLESS SPECIFIED) ANGULAR TOL ± 1.0 ° 4 PLACES ± 3 PLACES ± 2 PLACES ± 0.13 1 PLACE ± 0.25 0 PLACES ±			DIMENSION UNITS: MM SCALE: 1.25:1			
	DRWN BY: MKEMPEGOWDA DATE: 2016/04/13		CHKD BY: DSUN15 DATE: 2016/07/31		APPR BY: RCHEN08 DATE: 2016/08/04			SERIES: 111112 MATERIAL NUMBER: SEE SHEET 3 CUSTOMER:			
	DRAFT WHERE APPLICABLE MUST REMAIN WITHIN DIMENSIONS		DRAWING SIZE: C		THIRD ANGLE PROJECTION			DOCUMENT NUMBER: 1111122220 DOC TYPE: PSD DOC PART: ASY SHEET NUMBER: 3 OF 7		PRODUCT CUSTOMER DRAWING	

PCB LAYOUT - SINGLE SIDE ONLY

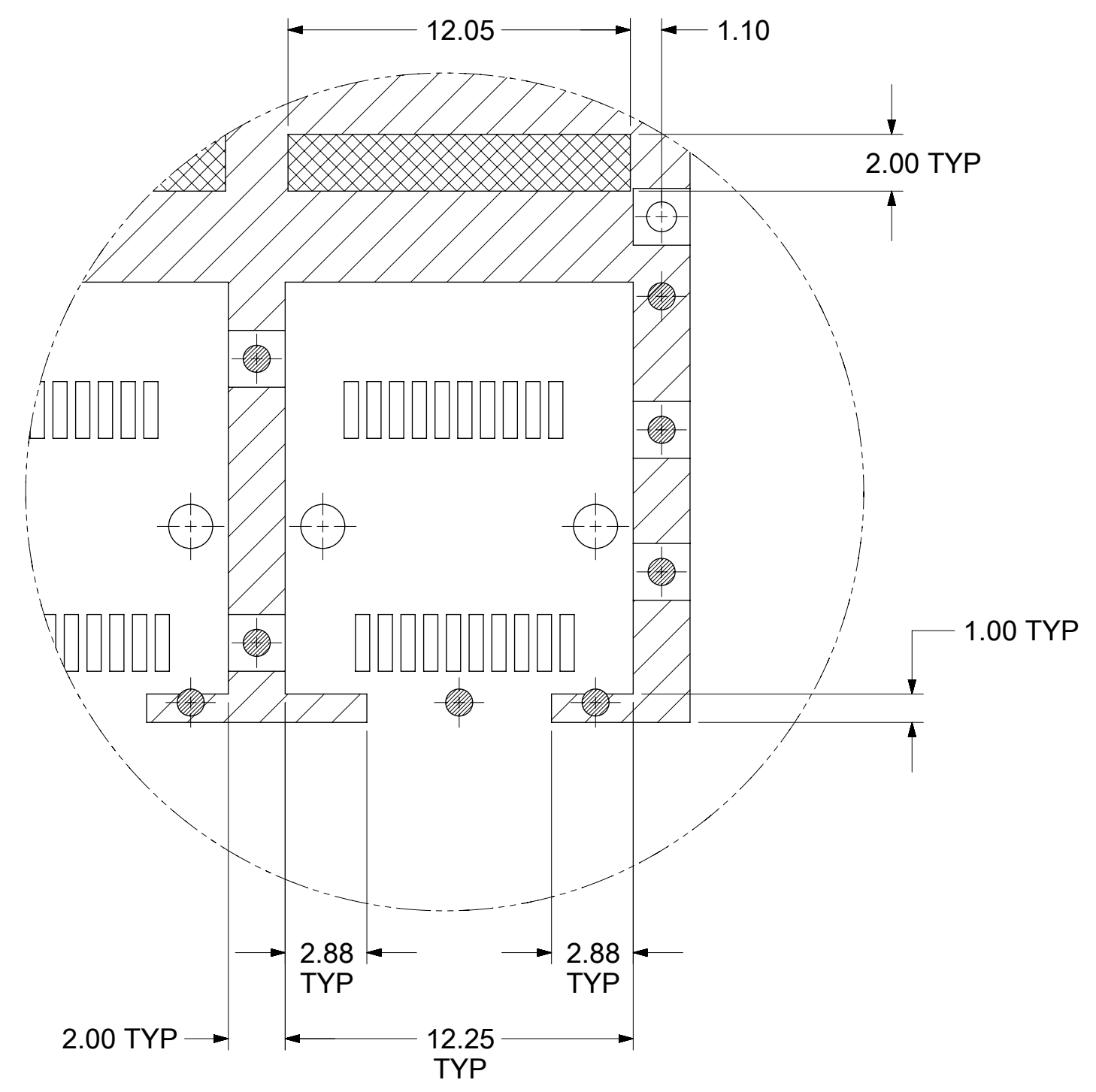
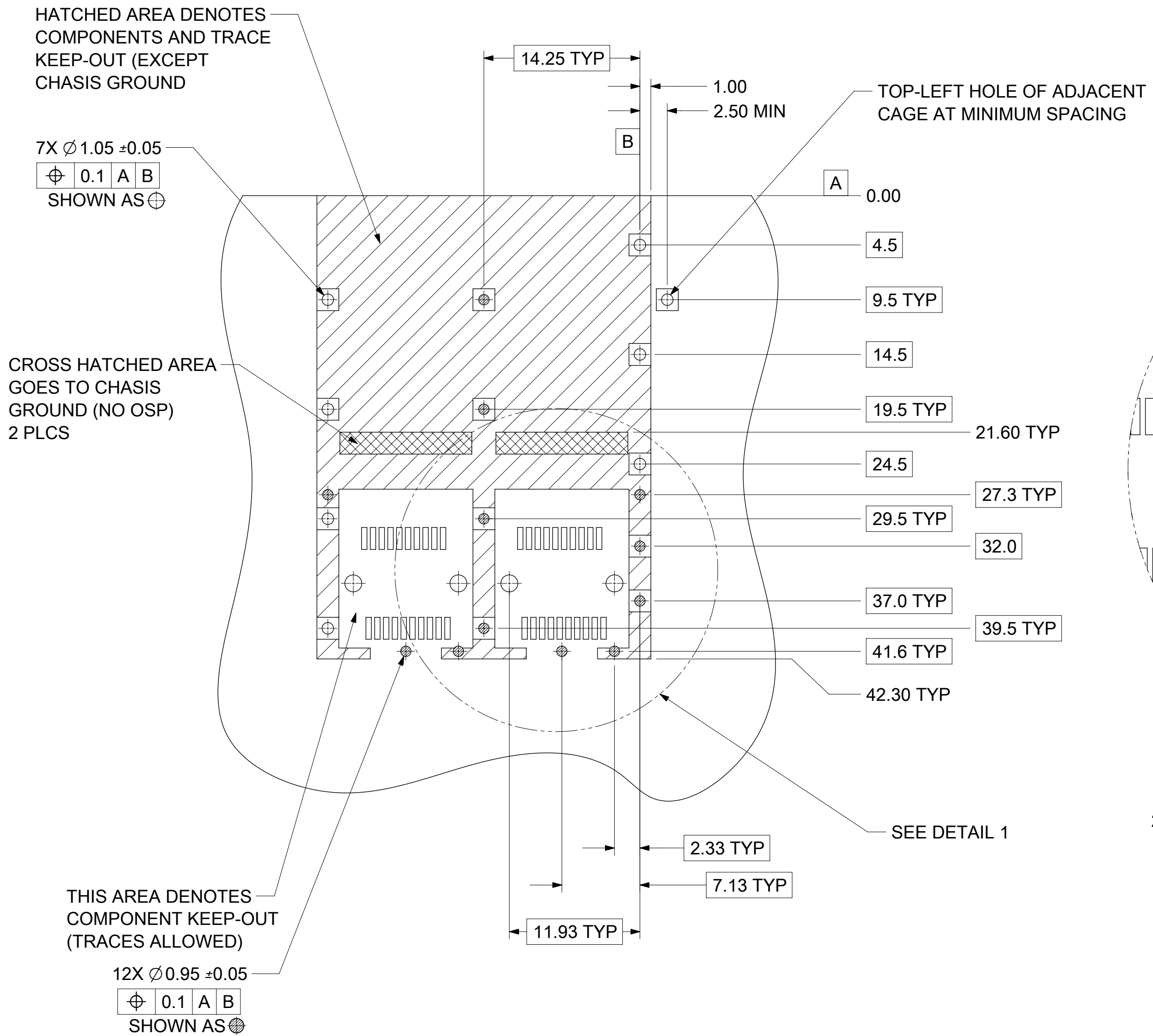

DETAIL 1
SCALE 5:1

- NOTES:
1. PADS AND VIAS CONNECT TO CHASSIS GROUND
RECOMMEND PADS TO BE 2.00mm SQUARE
 2. RECOMMENDED THRU HOLE PLATING INCLUDES HASL, OSP, OR IMMERSION (GOLD, SILVER, OR TIN)
 3. CONNECTOR PAD LAYOUT PER SFP+ MSA WILL ACCOMODATE MOLEX CONNECTOR SERIES 74441 OR EQUIVALENT.
 4. SPACING BETWEEN PORTS IS 14.25mm
 5. 1.57mm MINIMUM PCB THICKNESS FOR SINGLE SIDED USE.

QUALITY SYMBOLS		THIS DRAWING CONTAINS INFORMATION THAT IS PROPRIETARY TO MOLEX ELECTRONIC TECHNOLOGIES, LLC AND SHOULD NOT BE USED WITHOUT WRITTEN PERMISSION										
▽ = 0	▽ = 0	SEE REVISION TABLE EC NO: 111626 DRWN: SJLG CHKD: DSUN15 REV: APPR: RCHEN08 DATE: 2016/12/21 DATE: 2016/12/21 DATE: 2016/12/21	GENERAL TOLERANCES (UNLESS SPECIFIED)			DIMENSION UNITS		SCALE				
▽ = 0	▽ = 0		ANGULAR TOL ± 1.0 °			MM		1:1				
▽ = 0	▽ = 0		4 PLACES ±			DRWN BY		DATE		SFP+ 1X2 CAGE, 3.05 MM PRESS FIT, HEAT SINK, EMI SPRING FINGERS		
▽ = 0	▽ = 0		3 PLACES ±			MKEMPEGOWDA		2016/04/13				
▽ = 0	▽ = 0		2 PLACES ± 0.13			CHKD BY		DATE		PRODUCT CUSTOMER DRAWING		
▽ = 0	▽ = 0		1 PLACE ± 0.25			DSUN15		2016/07/31				
▽ = 0	▽ = 0	0 PLACES ±			APPR BY		DATE		SERIES: 111112 MATERIAL NUMBER: SEE SHEET 3 CUSTOMER:			
▽ = 0	▽ = 0	DRAFT WHERE APPLICABLE MUST REMAIN WITHIN DIMENSIONS			RCHEN08		2016/08/04					
▽ = 0	▽ = 0	DRAWING SIZE		THIRD ANGLE PROJECTION		C		DOCUMENT NUMBER: 1111122220 DOC TYPE: PSD DOC PART: ASY SHEET NUMBER: 4 OF 7				

PCB LAYOUT FOR BELLY TO BELLY MOUNTING

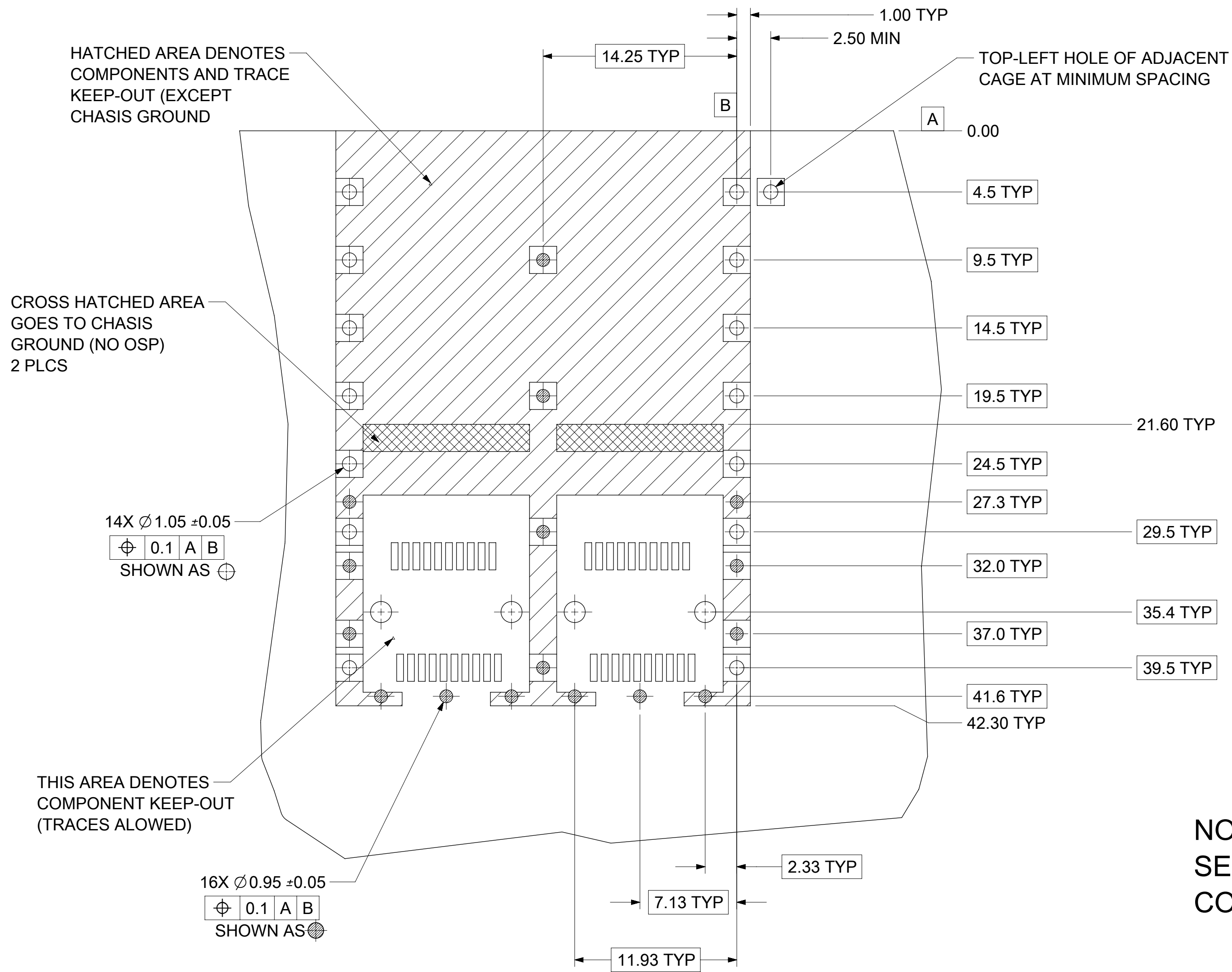

NOTE:
SEE SHEET 4 FOR HOST CONNECTOR DETAIL

NOTES:

- PADS AND VIAS CONNECT TO CHASSIS GROUND
RECOMMEND PADS TO BE 2.00mm SQUARE
- RECOMMENDED THRU HOLE PLATING INCLUDES HASL, OSP, OR IMMERSION (GOLD, SILVER, OR TIN)
- CONNECTOR PAD LAYOUT PER SFP+ MSA WILL ACCOMODATE MOLEX CONNECTOR SERIES 74441 OR EQUIVALENT.
- SPACING BETWEEN PORTS IS 14.25mm
- 3.00mm [.118 INCH] MINIMUM PCB THICKNESS FOR BELLY TO BELLY USE.

QUALITY SYMBOLS		THIS DRAWING CONTAINS INFORMATION THAT IS PROPRIETARY TO MOLEX ELECTRONIC TECHNOLOGIES, LLC AND SHOULD NOT BE USED WITHOUT WRITTEN PERMISSION		DIMENSION UNITS		SCALE		molex	
∇ = 0	∇ = 0	GENERAL TOLERANCES (UNLESS SPECIFIED)		MM		4:1			
∇ = 0	∇ = 0	ANGULAR TOL $\pm 1.0^\circ$		DRWN BY		DATE		SFP+ 1X2 CAGE, 3.05 MM PRESS FIT, HEAT SINK, EMI SPRING FINGERS	
∇ = 0	∇ = 0	4 PLACES \pm		MKEMPEGOWDA		2016/04/13			
∇ = 0	∇ = 0	3 PLACES \pm		CHKD BY		DATE		PRODUCT CUSTOMER DRAWING	
∇ = 0	∇ = 0	2 PLACES ± 0.13		DSUN15		2016/07/31			
∇ = 0	∇ = 0	1 PLACE ± 0.25		APPR BY		DATE		SERIES MATERIAL NUMBER CUSTOMER	
∇ = 0	∇ = 0	0 PLACES \pm		RCHEN08		2016/08/04			
\boxtimes = 0	\blacksquare = 0	DRAFT WHERE APPLICABLE MUST REMAIN WITHIN DIMENSIONS		DRAWING SIZE		THIRD ANGLE PROJECTION		111112 SEE SHEET 3	
∇ = 0				C				DOCUMENT NUMBER 1111222220 DOC TYPE PSD DOC PART ASY SHEET NUMBER 5 OF 7	

BEZEL AND BOARD POSITION DIMENSIONS FOR SINGLE SIDE MOUNTING (SPRING FINGER)

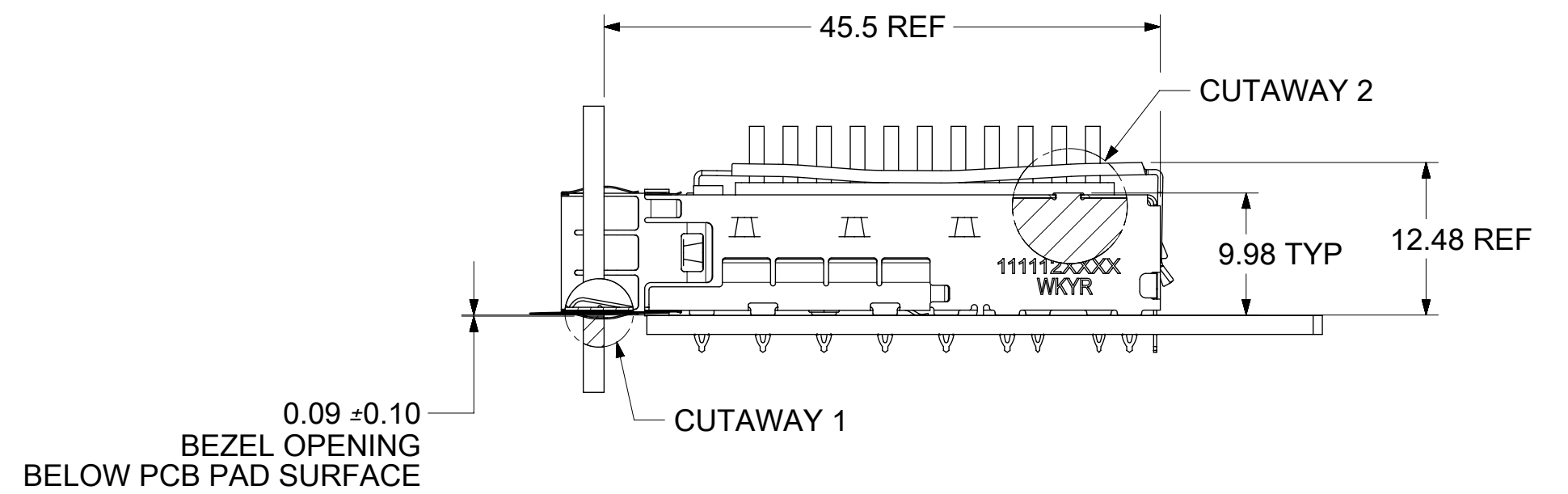
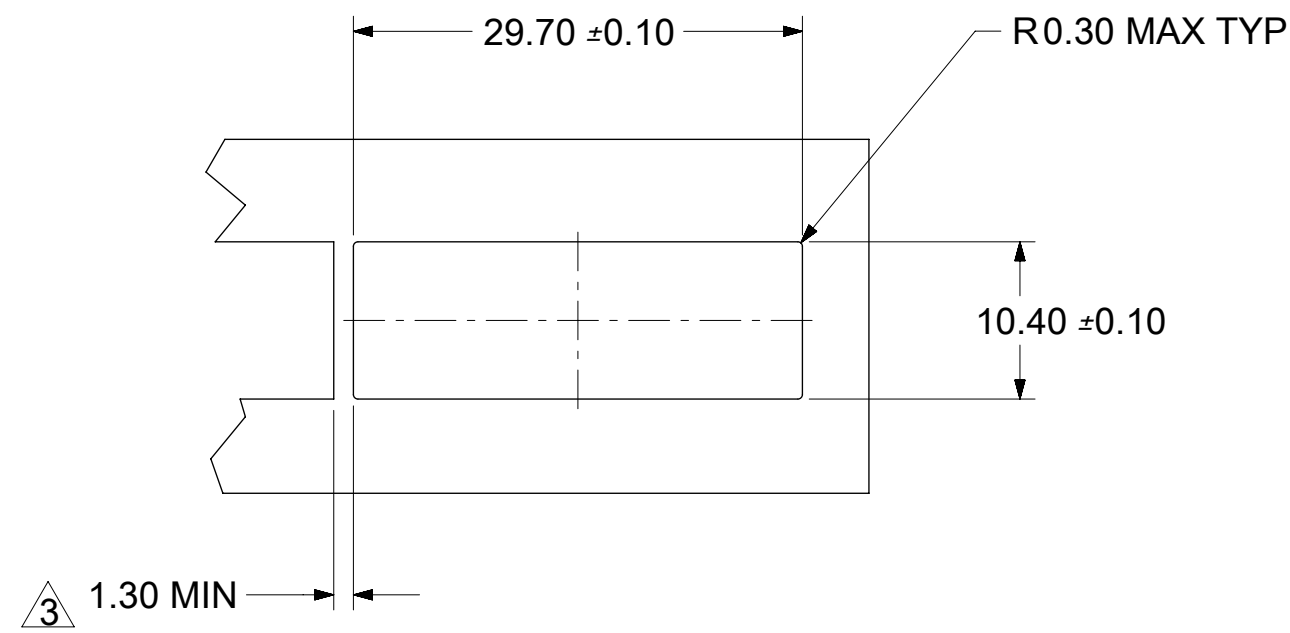

BEZEL AND BOARD POSITION DIMENSIONS FOR BELLY TO BELLY MOUNTING (SPRING FINGER)

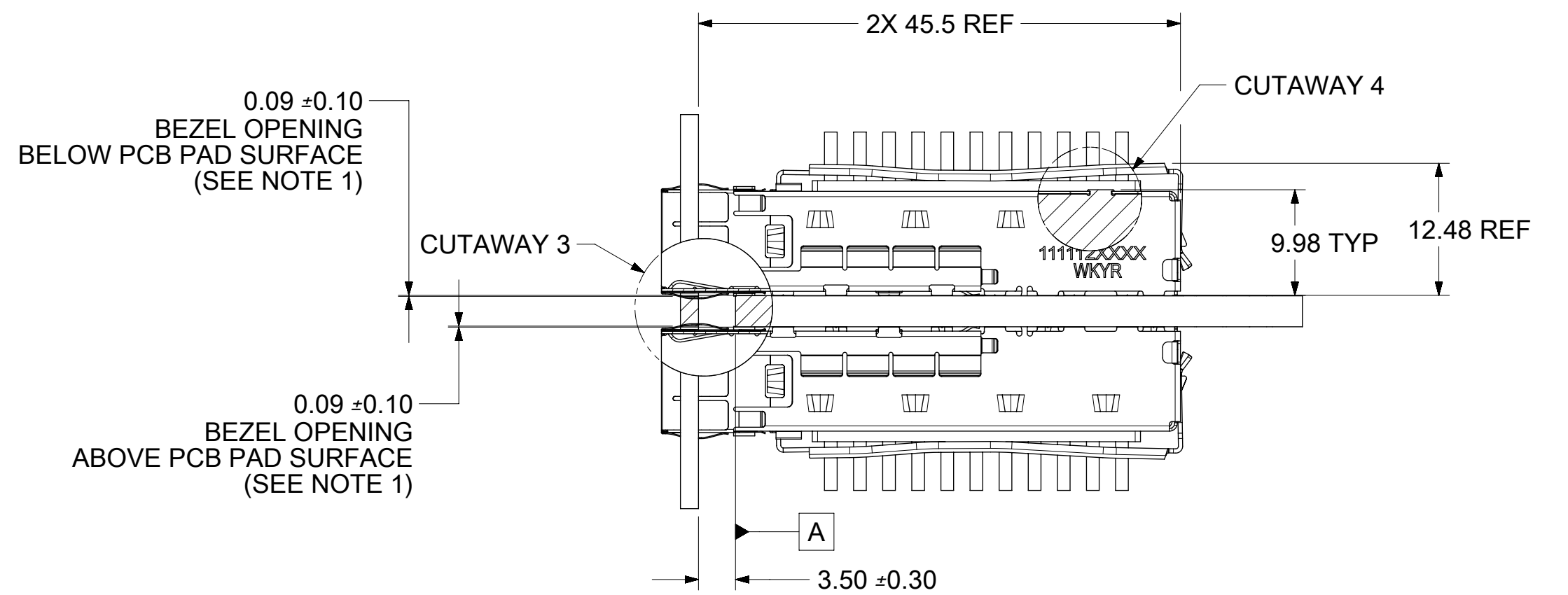
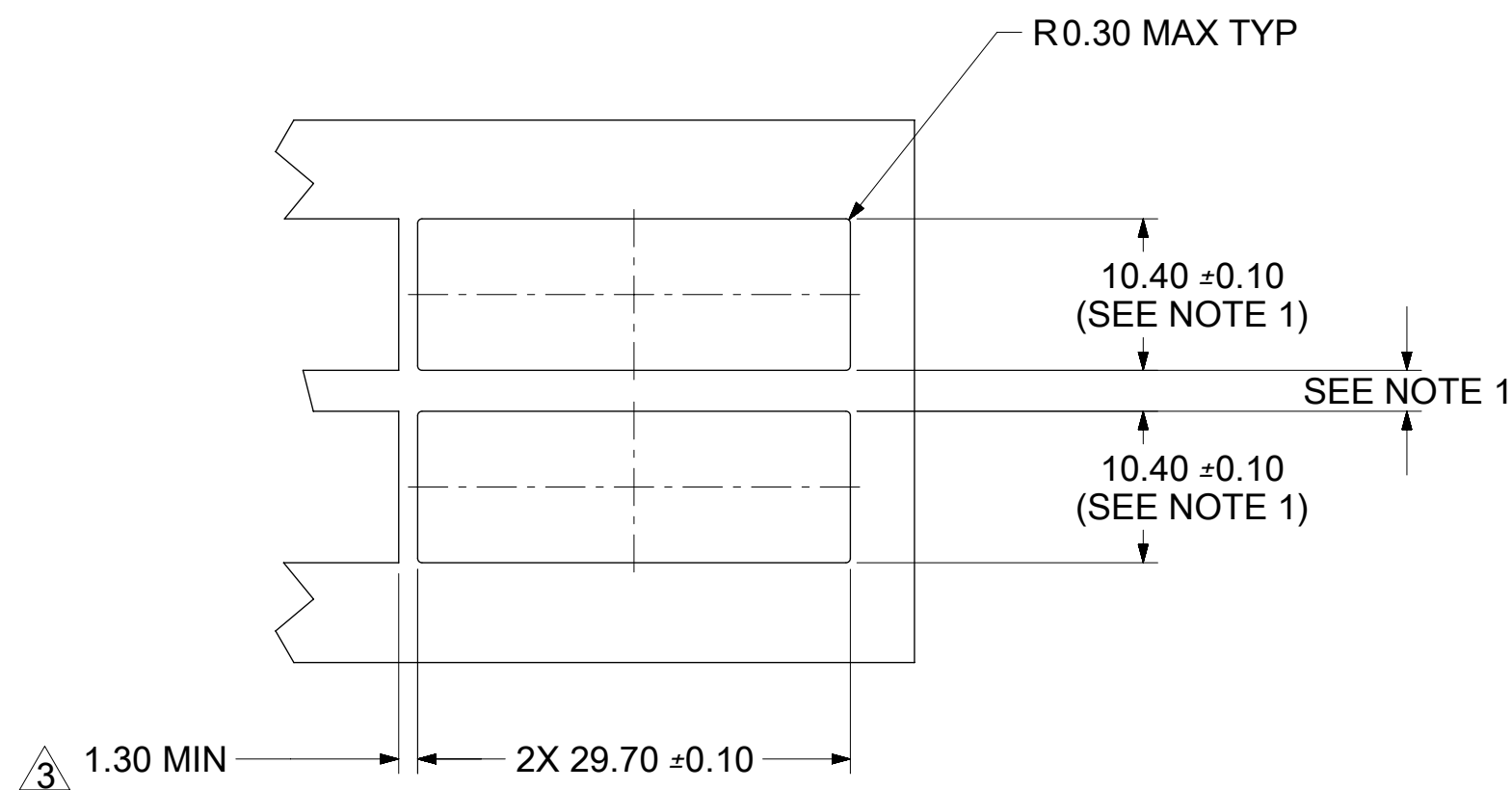

- NOTE:**
1. PCB THICKNESS VARIATION MUST BE CONSIDERED WHEN DETERMINING BEZEL OPENING SIZE AND LOCATION.
 2. CAGE LEG STANDOFF WILL PIERCE BELLY GASKET WHEN PROPERLY PRESSED INTO PCB.
 3. THIS DIMENSION IS FOR REF ONLY. USER CAN MODIFY IT DEPENDS ON APPLICATION. HOLE OF ADJACENT CAGE ON PCB LAYOUT VARIES ON MODIFICATION.

QUALITY SYMBOLS		THIS DRAWING CONTAINS INFORMATION THAT IS PROPRIETARY TO MOLEX ELECTRONIC TECHNOLOGIES, LLC AND SHOULD NOT BE USED WITHOUT WRITTEN PERMISSION									
▽ = 0	▽ = 0	GENERAL TOLERANCES (UNLESS SPECIFIED)		DIMENSION UNITS		SCALE		molex SFP+ 1X2 CAGE, 3.05 MM PRESS FIT, HEAT SINK, EMI SPRING FINGERS			
▽ = 0	▽ = 0	ANGULAR TOL ± 1.0 °		MM		2:1					
▽ = 0	▽ = 0	4 PLACES ±		DRWN BY		DATE		PRODUCT CUSTOMER DRAWING			
▽ = 0	▽ = 0	3 PLACES ±		MKEMPEGOWDA		2016/04/13					
▽ = 0	▽ = 0	2 PLACES ± 0.13		CHKD BY		DATE		SERIES MATERIAL NUMBER CUSTOMER			
▽ = 0	▽ = 0	1 PLACE ± 0.25		DSUN15		2016/07/31					
▽ = 0	▽ = 0	0 PLACES ±		APPR BY		DATE		DOCUMENT NUMBER DOC TYPE DOC PART SHEET NUMBER			
▽ = 0	▽ = 0	DRAFT WHERE APPLICABLE MUST REMAIN WITHIN DIMENSIONS		RCHEN08		2016/08/04					
▽ = 0	▽ = 0	SEE REVISION TABLE		DRAWING SIZE		THIRD ANGLE PROJECTION		111122220 PSD ASY 6 OF 7			
▽ = 0	▽ = 0	EC NO: 111626		C		[Third Angle Projection Symbol]					
▽ = 0	▽ = 0	2016/12/15		J2							
▽ = 0	▽ = 0	2016/12/21		REV							
▽ = 0	▽ = 0	2016/12/21									

REV	DATE	DESCRIPTION
A	2011/06/10	INITIAL RELEASE
A1	2011/06/15	SHEET 1: REMOVED HEATSINK OPENING REFERENCE DIMENSIONS AND WEEK 52 REFERENCE; SHEET 4: ADDED NOTES POINTING TO THE INNER WALL COINED OVER THE COVER.
B	2011/07/22	ADDED HOLES IN CAGE FOR LIGHTPIPES; MOVED DATE CODE; REVISED ROHS NOTE 5; CHANGED HEATSINK HEIGHT FROM 8.63 TO 6.5; TABULARIZED PCI, SAN, AND NETWORKING; AND ADDED HEATSINK HEIGHT WITH MODULE INSERTED.
B1	2011/08/19	UPDATED CAGE AND SPRING CLIP MODELS.
C	2012/10/25	SHEET 1: REMOVED HEATSINKS, AND ALL DIMS AND ANNOTATIONS RELATING TO THEM, FROM ALL VIEWS; REMOVED NOTE 6; REMOVED EXPLODED VIEW; REMOVED PART NUMBER TABLE; ADDED TITLE. NEW SHEET 2: ISO VIEWS OF CAGE WITH NO HEATSINKS AND VIEWS WITH EACH OF FOUR TYPES AND SIZES OF HEATSINK; ANNOTATIONS ON EACH VIEW INDICATING EACH HEATSINK TYPE AND SIZE; RIGHT SIDE VIEW WITH DIM OF HEATSINK HEIGHT; TABLE UNDER EACH VIEW WITH HEATSINK SIZES AND DIMS; NOTE 1; SHEET TITLE. NEW SHEET 3: ISO VIEWS OF CAGE WITH NO HEATSINKS AND VIEWS WITH EACH OF FOUR DIFFERENT TYPES OF HEATSINK; TABLES UNDER EACH VIEW WITH PART NUMBERS OF EACH SIZE; SHEET TITLE.
D	2014/02/07	SHEET 1: REVISED ALL BASE CAGE DETAILS AND VIEWS FROM 111112-0232 TO 74754-0220. REMOVED INSERTION FORCE INTO PCB FROM NOTE 2. REVISED NOTE 4: "WAS" WELD SPOT WILL SHOW SLIGHT MATERIAL DISCOLORATION. "NOW READS" WELD SPOT MAY SHOW SLIGHT MATERIAL DISCOLORATION. SHEET 2: REVISED ALL HEAT SINK CAGE ASSEMBLY OPTIONS. ADDED OPEN TOP VIEW WITH DIMENSIONS, AND REAR LEG OPTION VIEW. SHEET 3: ADDED SHEET 3 WITH ZSFP+ OPTIONS SHEET 4: ADDED PART NUMBERS 747540220, 1001130220. UPDATED TITLE BLOCK.
E	2014/08/13	SHEET 1: ADDED "REF" TO DIM 10.85 AND 28.25. ADDED 14.0 ±0.1. MOVED "MINIMUM PCB THICKNESS" NOTES FROM SHEET 1 TO SHEETS 5 AND 6.
F	2014/08/21	SHEET 1: ADDED 747540247 NO NEED PRINTED @C6. SHEET 1: ADDED P/N AND DATE CODE PRINTED NOTE @D11. SHEET 4: ADDED P/N 747540247 IN TABLE @I18.
G	2015/02/26	SHEET 3: ADDED NOTE 1 "UNDER BELLY GASKET IS UL94 V-0 RATED." SHEET 4: ADDED "5 WELD POINTS" INTO 747540220 @I17. SHEET 4: ADDED P/N 747540222 @I17. SHEET 7: ADDED NOTE 2 "CAGE LEG STANDOFF WILL PIERCE BELLY GASKET WHEN PROPERLY PRESSED INTO PCB."
H	2015/08/26	SHEET 2: E3 : ADDED NEW CUSTOM FIN HEATSINK ISO VIEW SHEET 4: E3 : ADDED PART NO. 111112-6221 ISO VIEW MODIFIED PCB LAYOUT PER SFF-8433 SHEET 5: K19 : CHANGED TURE POSITION OF PCB HOLES FORM 0.05 TO 0.1 D17 : CHANGED TURE POSITION OF PCB HOLES FORM 0.05 TO 0.1 SHEET 6: G19 : CHANGED TURE POSITION OF PCB HOLES FORM 0.05 TO 0.1 B18 : CHANGED TURE POSITION OF PCB HOLES FORM 0.05 TO 0.1
J	2016/06/28	REMASTERED FROM SD-111112-2220 REV H TO "1111122220 REV_J" NX SHEET 2: E10: CHANGED THE PN /DATE CODE STYLE FROM 1 ROW TO 2 ROWS SHEET 7: A19:ADDED A NOTE "THIS DIM IS FOR REF ONLY. USER CAN MODIFY IT DEPENDS ON APPLICATION.HOLE OF ADJACENT CAGE ON PCB LAYOUT VARIES BASED ON MODIFICATION." SEPARATED ZSFP+ SERIES TO 1001130220 PSD ASY
J2	2016/12/16	SHEET 4/5: CORRECTED TYPO TO UPDATE PCB VIEW

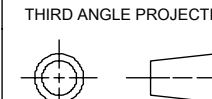
QUALITY SYMBOLS	THIS DRAWING CONTAINS INFORMATION THAT IS PROPRIETARY TO MOLEX ELECTRONIC TECHNOLOGIES, LLC AND SHOULD NOT BE USED WITHOUT WRITTEN PERMISSION										
▽ = 0	SEE REVISION TABLE EC NO: 111626 DRWN: SJLG CHKD: DSUN15 REV APPR: RCHEN08 2016/12/15 2016/12/21 2016/12/21	GENERAL TOLERANCES (UNLESS SPECIFIED)		DIMENSION UNITS	SCALE						
▽ = 0		ANGULAR TOL ± 1.0 °		MM	1:1						
▽ = 0		4 PLACES ±		DRWN BY	DATE	SFP+ 1X2 CAGE, 3.05 MM PRESS FIT, HEAT SINK, EMI SPRING FINGERS					
▽ = 0		3 PLACES ±		MKEMPEGOWDA	2016/04/13						
▽ = 0		2 PLACES ± 0.13		CHKD BY	DATE	PRODUCT CUSTOMER DRAWING					
▽ = 0		1 PLACE ± 0.25		DSUN15	2016/07/31						
□ = 0		0 PLACES ±		APPR BY	DATE	SERIES MATERIAL NUMBER CUSTOMER 111112 SEE SHEET 3					
■ = 0		DRAFT WHERE APPLICABLE MUST REMAIN WITHIN DIMENSIONS		RCHEN08	2016/08/04						
▽ = 0		DRAWING SIZE		THIRD ANGLE PROJECTION		DOCUMENT NUMBER		DOC TYPE	DOC PART	SHEET NUMBER	
		C				1111122220		PSD	ASY	7 OF 7	