

AT SERIES

AC Current Transducers

AT Series AC Current Transducers combine a current transformer and signal conditioner into a single package. These current transducers have jumper-selectable current input ranges and industry standard 4–20 mA, 0–5 VDC or 0–10 VDC outputs. The AT Series AC Current Transducers are designed for application on 'linear' or sinusoidal AC loads and are available in a split-core case or two types of solid-core cases.



AC Current Transducer Applications

Automation Systems

- Analog current reading for remote monitoring and software alarms.

Data Loggers

- Self-powered transducer helps conserve data logger batteries.

Panel Meters

- Simple connection displays power consumption.

Preventative Maintenance of a Critical Lighting System

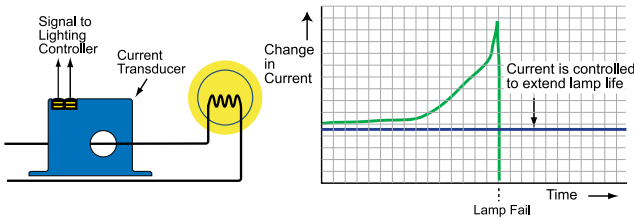

- For additional Application Examples, go to www.nktechnologies.com/applications

AT Series Power Supply

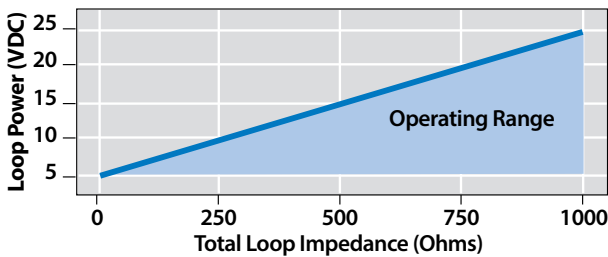

AC Current Transducer Features

Accurate

- Factory matched and calibrated single piece transducer is more accurate than traditional two-piece field installed solutions.

Average Responding

- "Average Responding" algorithm gives an RMS output on pure sine waves. Perfect for constant speed (linear) loads.

Jumper-selectable Ranges

- Reduces inventory.
- Eliminates zero and span pots.

Isolation

- Output is magnetically isolated from the input for safety.
- Eliminates insertion loss (voltage drop).

UL/cUL and CE Approved

- Accepted worldwide.

AC Current Transducer Connections

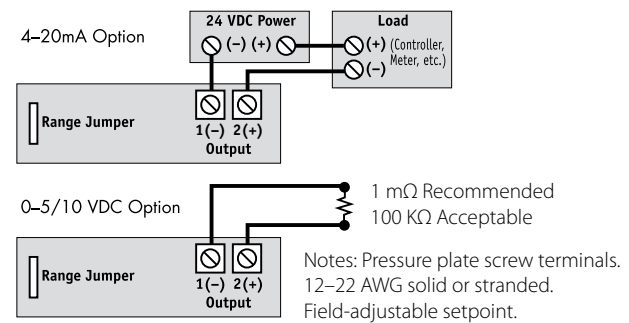

OEMs Test & Evaluation Units for OEMs
Free program expedites evaluation process. See page 3 for details.

AC Current Transducer Dimensions

FF Case

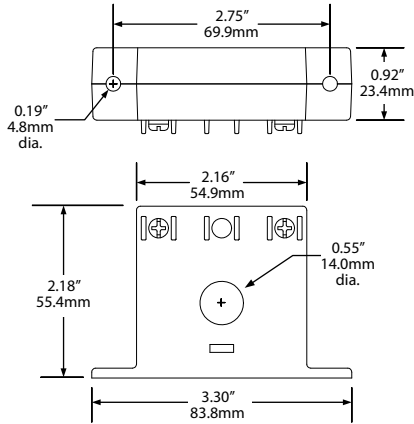

FT Case

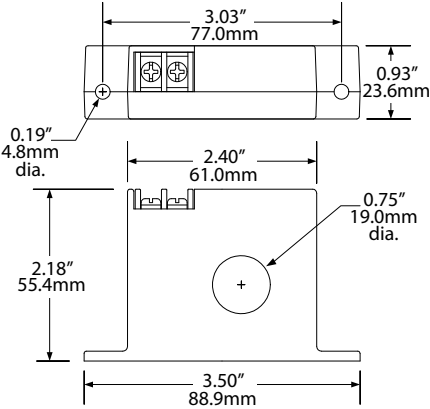

SP Case

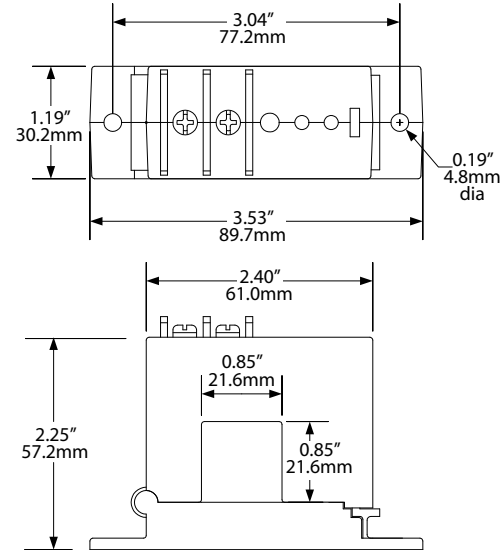

AC Current Transducer Specifications



	-005 MODEL	-010 MODEL	-420 MODEL
Power Supply	None, self-powered		5-40 VDC, loop-powered
Output Signal	0-5 VDC	0-10 VDC	4-20 mA
Output Limit	8.2 VDC	15 VDC	32 mA
Output Impedence	1 megohm min., 100 KΩ add 1.3% error		Contact factory for power requirements
Accuracy	1.0% FS		
Response Time (90% step change)	100 ms		300 ms
Frequency Range	50-60 Hz		20-100 Hz*
Isolation Voltage	UL listed to 1270 VAC, tested to 5 KV		
Input Range	0-200 A field-selectable; custom ranges available, consult factory		
Case	UL94 V-0 Flammability rated		
Environmental	-4 to 122°F (-20 to 50°C) 0-95% RH, non-condensing		
Listing	UL/cUL, CE		

*For sinusoidal waveforms only. Select ATR Transducers for distorted waveforms.

AC Current Transducers

AC Current Transducer Ordering Information

Sample Model Number: AT1-005-000-SP
AC current transducer, 10/20/50 A range, self-powered with a 0-5 VDC output in a split-core case. (DIN rail adapters are included)

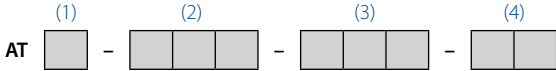

(1) Full Scale Range

0	2 & 5 A (4-20 mA only)
1	10, 20, 50 A
2	100, 150, 200 A

(2) Output Signal

420	4-20 mA
005	0-5 VDC
010	0-10 VDC

(3) Power Supply

24L	24 VDC loop-powered (4-20 mA output only)
000	Self-powered (0-5/0-10 VDC output only)

(4) Case Style

FF	Solid-core, front terminal
FT	Solid-core, top terminal
SP	Split-core

