

MATERIAL NO.	ENGINEERING NO.	LENGTH	GASKET SEAL (MATERIAL/COLOR)	WIRE AWG
847290002	84729-0002	0.15M +.013/-0 (6.00in+.50/-0)	F2 NEOPRENE /BLACK	20
847290019	84729-0019	0.20M+.025/-0 (7.87in+1.00/-0)		
847290034	84729-0034	0.50M +.025/-0 (19.69in +1.00/-0)		
847290015	84729-0015	1.10M +0.25/-0 (43.31in +1.00/-0)	SILICONE/RED	28
847290029	84729-0029	0.15M +.013/-0 (6.00in+.50/-0)	NEOPRENE /BLACK	
847290001	84729-0001	0.15M +.013/-0 (6.00in+.50/-0)		
847290023	84729-0023	0.23M +.013/-0 (9.00in +.50/-0)		

1. MATERIALS: SEE TABLE
2. FINISHES: SEE TABLE
3. ELECTRICAL SPECS:  
VOLTAGE: 30V  
CURRENT: 1.0A
4. MAX PANEL THICKNESS: .10
5. PANEL NUT TORQUE: 24 ±4 IN. LBS
6. DIMS SHOWN ARE FOR REFERENCE UNLESS NOTED OTHERWISE
7. PRODUCT SPEC: PS-84727-002

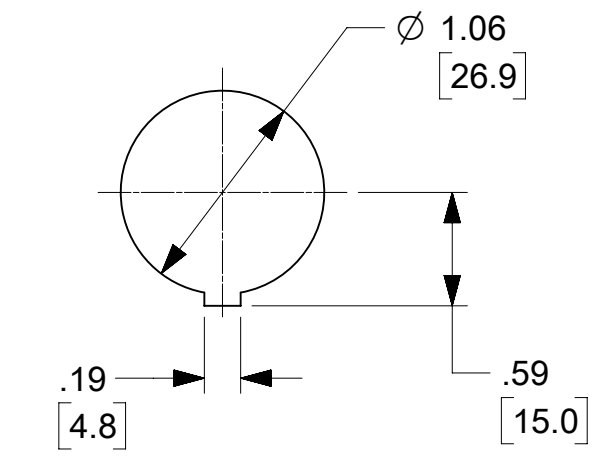

REF. PANEL CUTOUT  
SCALE: 1X

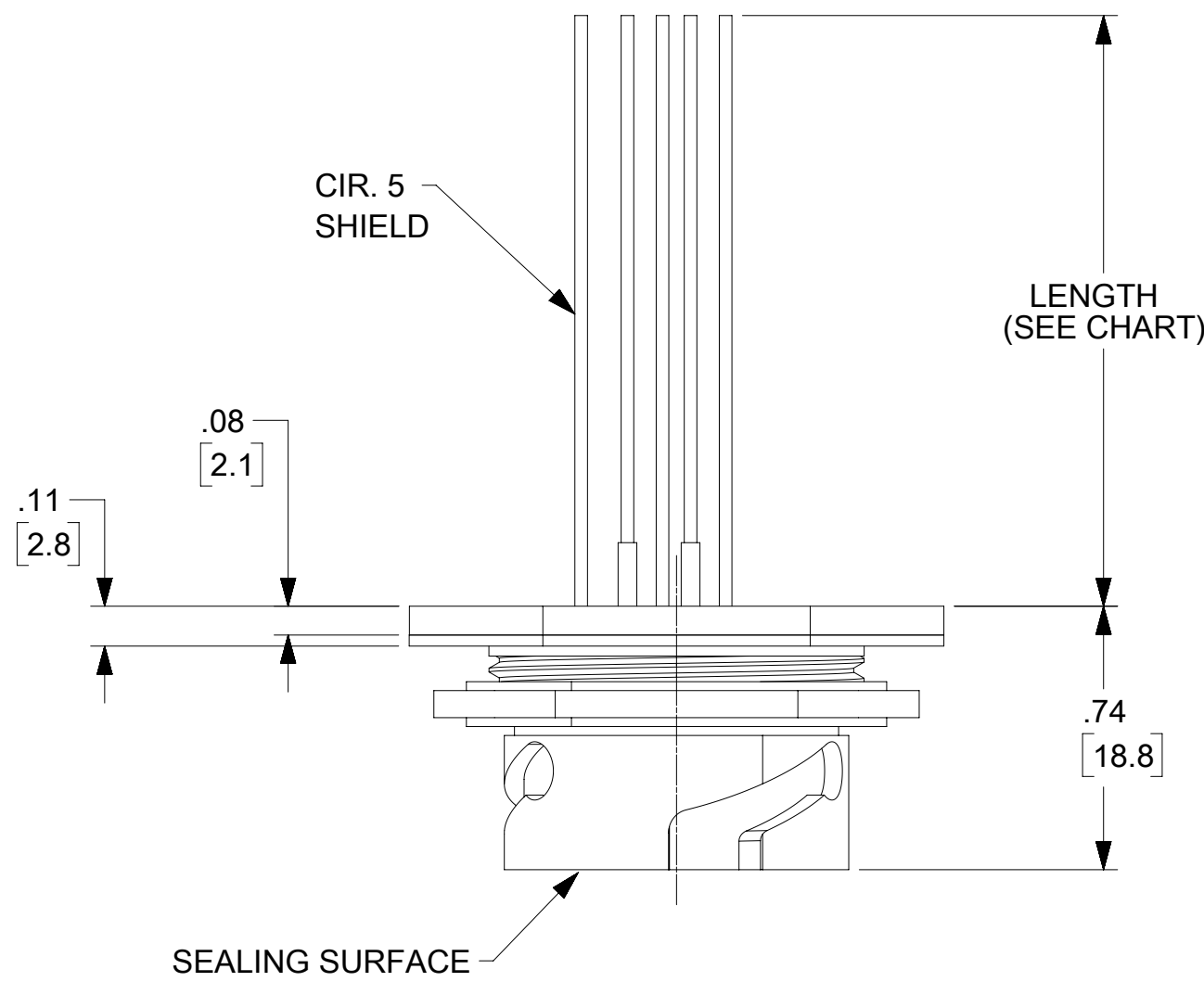
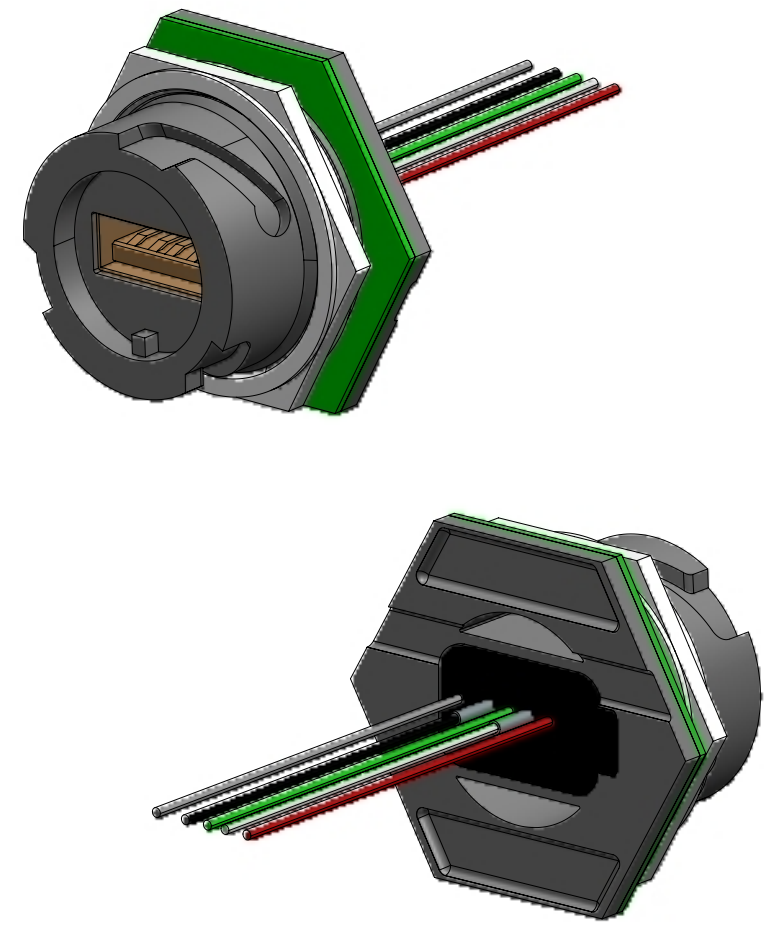

- |   |       |
|---|-------|
| 1 | RED   |
| 2 | WHITE |
| 3 | GREEN |
| 4 | BLACK |
| 5 | GRAY  |

USB SHELL

WIRING DIAGRAM

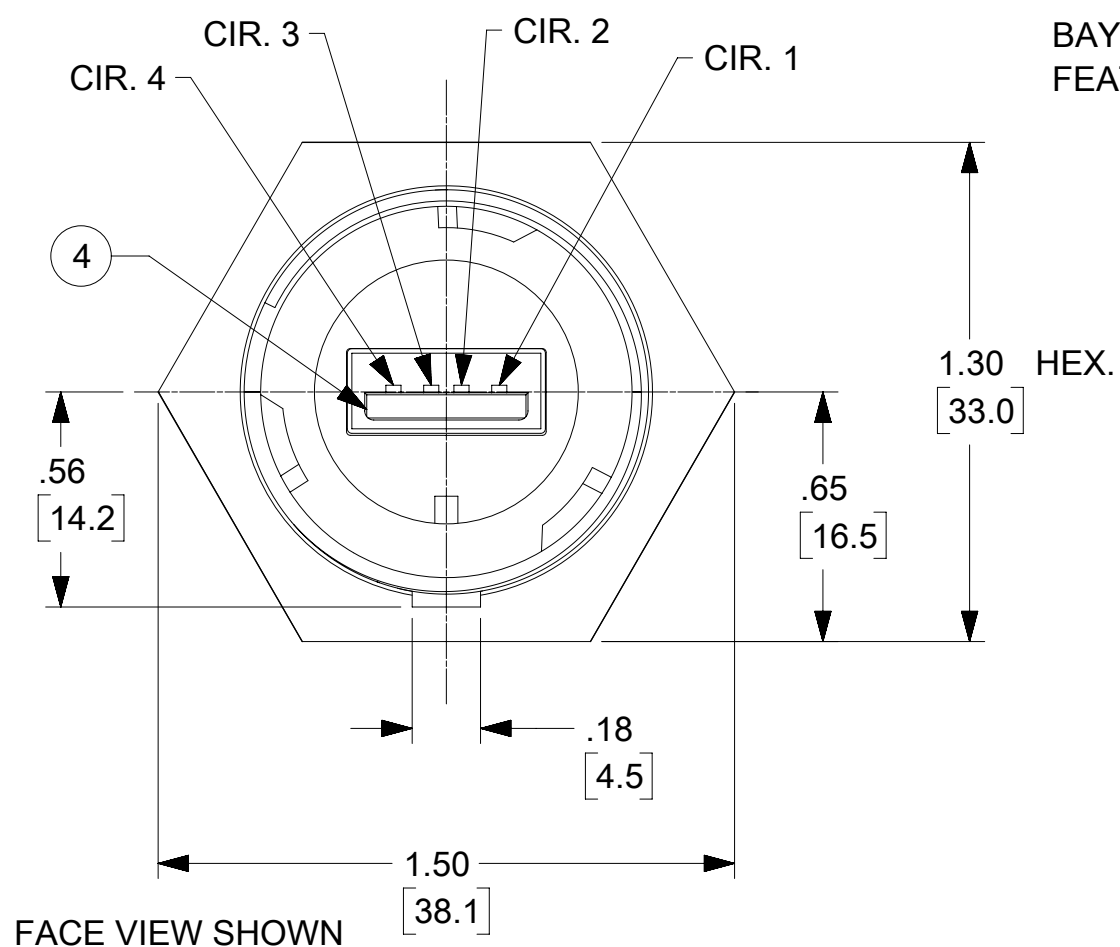
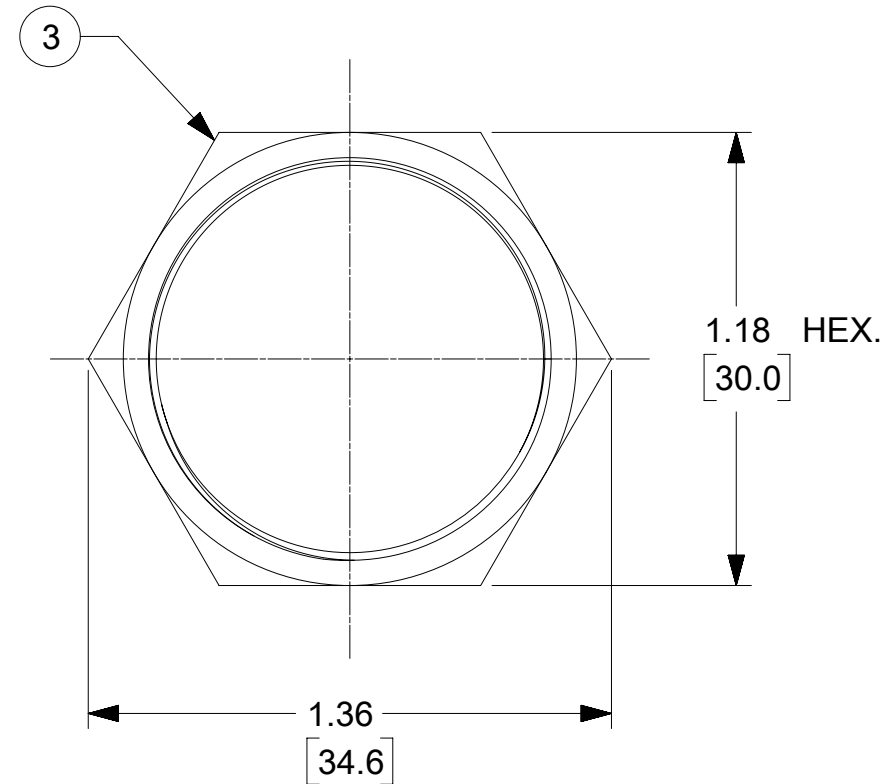

FACE VIEW SHOWN WITHOUT LOCKNUT OR GASKET SEAL

BAYONET LOCKING FEATURE

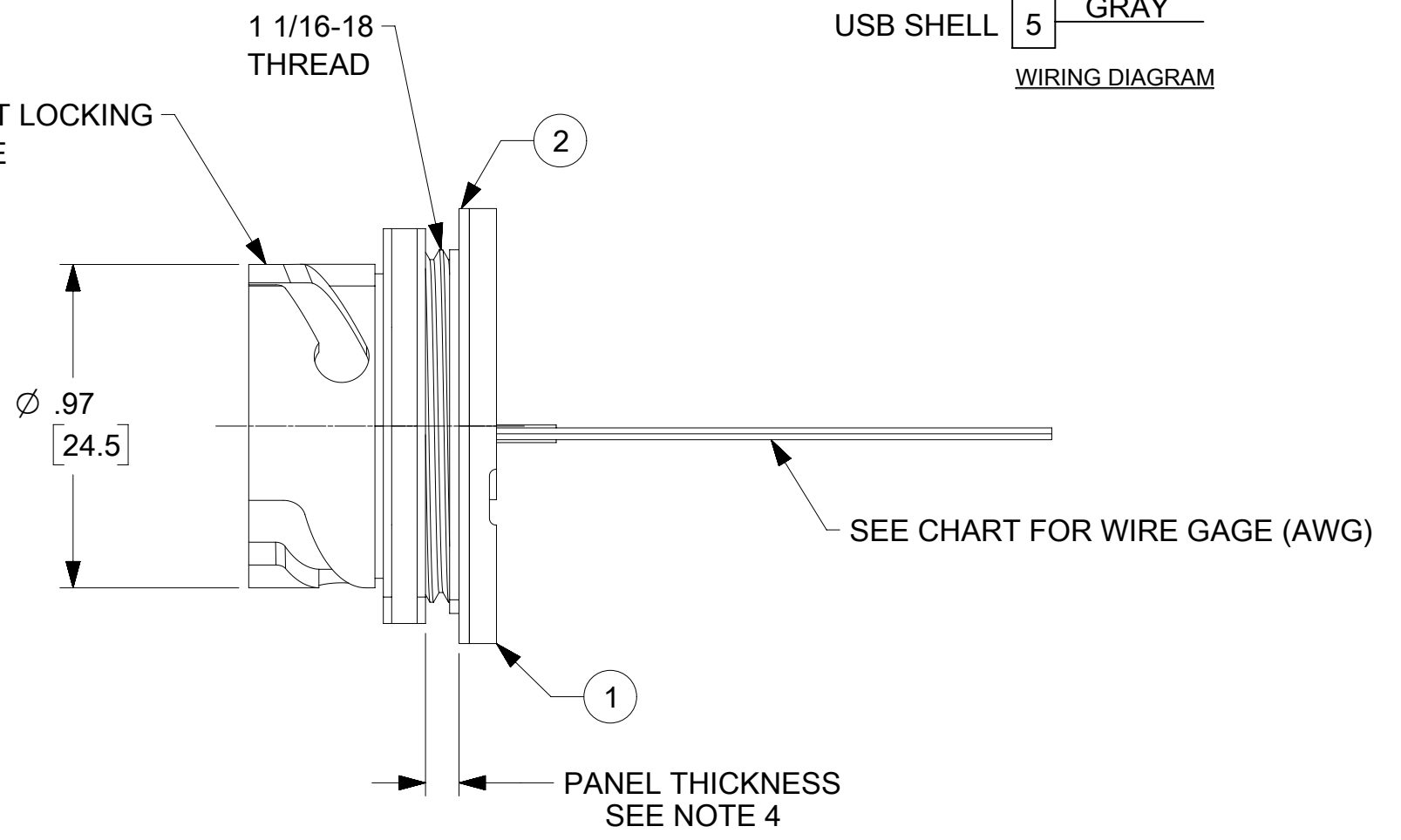

TABLE

ITEM	DESCRIPTION	MATERIAL	FINISH
4	USB-A RECEPTACLE	Cu ALLOY	GOLD PLTD CONTACTS
3	LOCKNUT	NYLON	BLACK
2	GASKET SEAL	SEE MAT. NO. CHART	
1	USB RECEPTACLE, PANEL MOUNT	PBT	BLACK

SYMBOLS		THIS DRAWING CONTAINS INFORMATION THAT IS PROPRIETARY TO MOLEX ELECTRONIC TECHNOLOGIES, LLC AND SHOULD NOT BE USED WITHOUT WRITTEN PERMISSION	
▽ = 0	INCH	CURRENT REV / DESC: ADD P/N 847290034	
▽ = 0	GENERAL TOLERANCES (UNLESS SPECIFIED)	EC NO: 629451	
▽ = 0	MM	DRWN: RSTONE	2019/07/10
▽ = 0	INCH	CHK'D: MZIELINSKI	2019/12/19
▽ = 0	4 PLACES ±	APPR: BWOODMAN	2019/12/20
▽ = 0	3 PLACES ±	INITIAL REVISION:	
▽ = 0	2 PLACES ±	DRWN: R. STONE	2006/06/01
▽ = 0	1 PLACE ±	APPR: R. DEROSS	2006/06/01
▽ = 0	0 PLACES ±	THIRD ANGLE PROJECTION	
▽ = 0	ANGULAR TOL ± °	DRAWING	SERIES
▽ = 0	DRAFT WHERE APPLICABLE MUST REMAIN WITHIN DIMENSIONS	C-SIZE	84729

DOCUMENT NUMBER		DOC TYPE	DOC PART	REVISION
SD-84729-005		PSD	000	F2
MATERIAL NUMBER		CUSTOMER		SHEET NUMBER
SEE MAT. NO. CHART		GENERAL MARKET		1 OF 1