

ACW4 CANopen

CANOPEN ABSOLUTE SINGLE TURN MODULAR SENSOR

Sensata-BEI Sensors' ACW4 sensors provide absolute single turn measurement with a CANopen output in an over-molded, two-part package that offers design flexibility & protection from the environment.



Features

- With its two-part design, the ACW4 CANopen absolute single-turn offers maximum flexibility for installation
- Rugged and excellent resistance to shock and vibration
- Robust, proven magnetic technology
- Environmentally resistant, IP 67 standard (IP69K option)
- Extended operating range from -30° C to 85° C
- Uses universal supply 5 to 30 VDC – CAN open output
- Available Resolution up to 12 bits per revolution
- Variety of magnet holders available
- Standard PVC cable with SUBD9 connector

Applications

- Factory Automation
- Process Automation



SPECIFICATIONS

Mechanical

Terminations	PVC Cable with SUBD9 connector
Housing	Macromelt PA638
Weight	0,150 kg

Electrical

Electrical Angle	360°
Output Function	CANopen
Minimal Cycle Time	< 400µs
Resolution	Single –turn, 12 bits
Accuracy	+/-0.3% on 360°
Repeatability	+/-0.1% on 360°
Supply Voltage	5 to 30 Vdc
Start-up	< 1 s
Current Requirements	< 40mA
Protection	Overvoltage Protection: Yes Reverse Polarity Protection: Yes Short Circuit Protection: Yes
EMC	IEC 61000-4-2 Electrostatic discharge (ESD) 4 kV, 8 kV IEC 61000-4-3 Electromagnetic fields 10 V/m (80MHz - 1GHz), 3V/m (1.4GHz - 2GHz), 1V/m (2GHz - 2.7GHz) IEC 61000-4-4 Electrical fast transients (burst) 1 kV IEC 61000-4-6 Conducted disturbances, induced by RF-fields 10 Veff.

Programmable Parameters

Resolution: Defines the resolution per revolution (0 to 4 096).

Transmission Speed: Programmable from 10kbaud (1 000m) to 1 Mbaud (25 m) ; value per default : 20 Kbaud.

Address: Defines the software address of the encoder on the bus (1 to 127, Value per default : id = 1).

Direction: Defines the direction of count of the sensor.

RAX: Defines the value of the current position (with the shaft held stationary)

CAMs: High and low limits.

Communication Modes

Sensor Configuration : Reading/Writing of the encoder objects dictionary (SDO mode).

3 modes are available to interrogate the encoder position/speed:

CYCLIC Mode: The sensor transmits its position in an asynchronous manner. The frequency of the transmission is defined by the programmable cyclic timer register from 0 to 65 535 ms,

SYNCHRO Mode: The Sensor transmits its position on a synchronous demand by the master.

POOLING Mode (Answer to a RTR signal) : The sensor only answers to a request.

DIMENSIONS

All Dimensions are in millimeters.

Shaft system with magnet to be ordered separately (see Accessories).

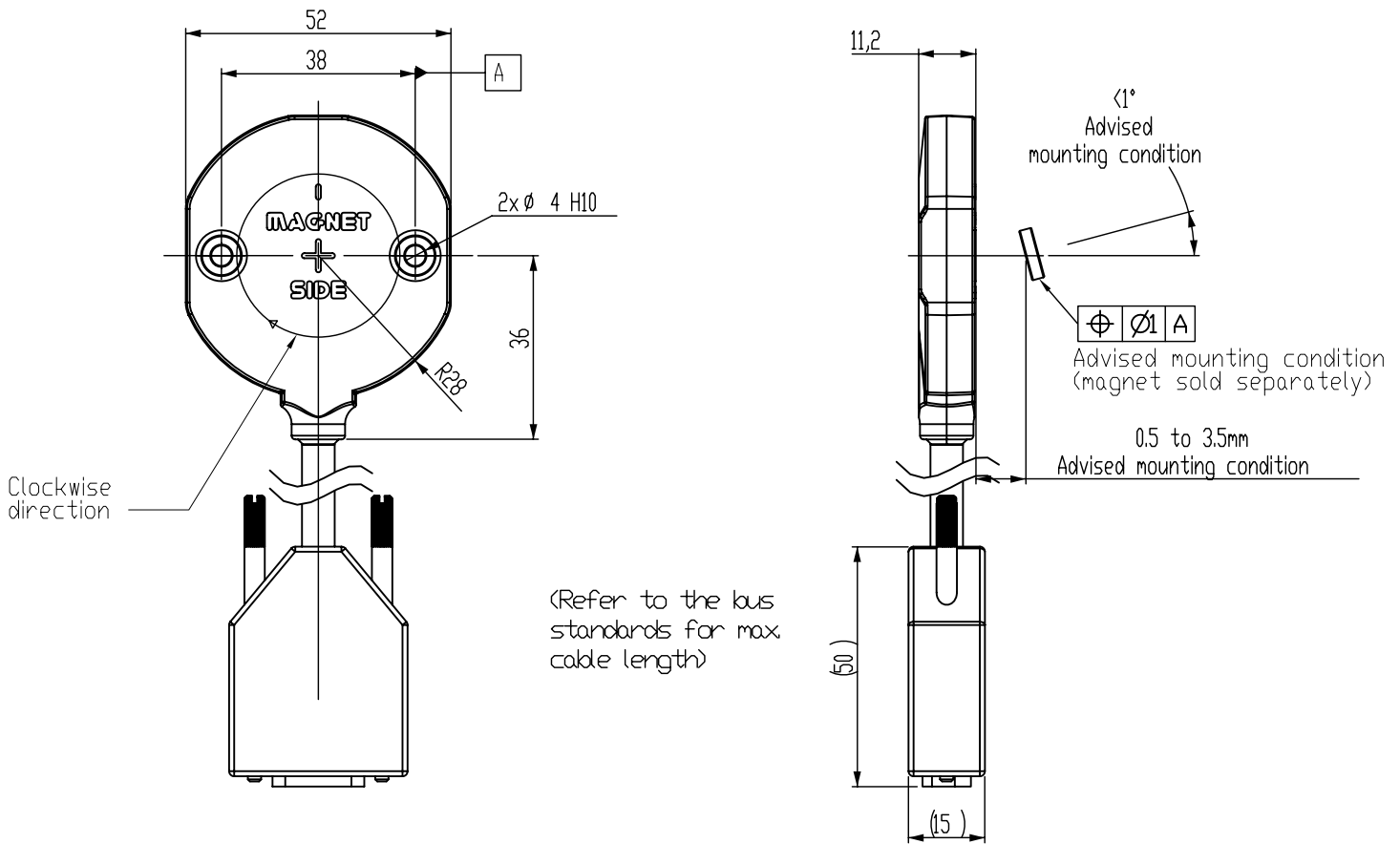

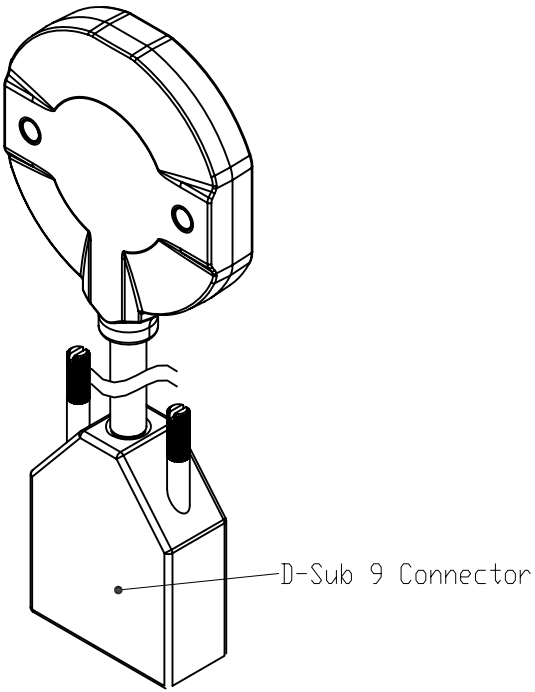

CONNECTIONS

		N.C	CAN LOW	CAN GND / 0V	N.C.	N.C.	0V	CAN HIGH	N.C.	5/30Vdc	Ground
BB	PVC Cable + DB9	1	2	3	4	5	6	7	8	9	General Shielding

NOTES

Stray magnetic fields can interfere with accuracy and repeatability of the signal.



ORDERING OPTIONS

Example : ACW4_00//PBB//12//BBR020

(Contact the factory for special versions, ex : dimensions, connections...)

	ACW4	00	//	P	BB	B	//	12	//	BBR	020
Family	ACW4: Absolute Single-Turn Sensor										
Shaft Ø	00: Modular										
Supply	P: 5 to 30 Vdc										
Output Stage	BB: CANopen										
Code	B: Binary										
Resolution	12: 12 bits										
Connection	BBR: Side PVC cable with SUBD9 connector										
Cable Length	020: 2 meters										



ACCESSORIES

Female magnet support + Magnet 8810/013

Ordering p/n : **M9105/Kxx**

KXX: Where XX is the shaft mounting diameter in mm. Standards are 06, 08, 10, 11, and 14 mm. i.e M9105/K10 mounts to a 10 mm shaft.

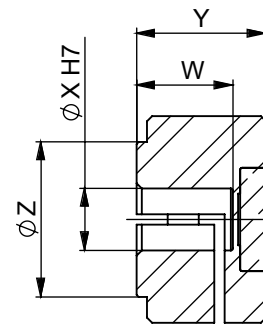
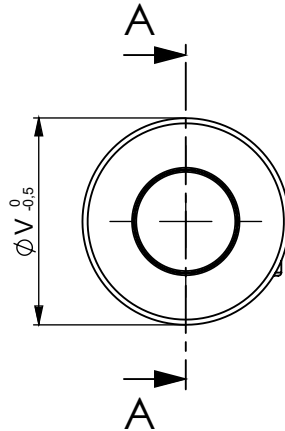
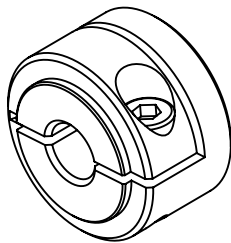

SECTION A-A

	M9105/K06	M9105/K08	M9105/K10	M9105/K11	M9105/K14
X	06 H7	08 H7	10 H7	11 H7	14 H7
V	20	20	26	26	29
W	9,3	9,3	10	10	10
Y	12,5	12,5	14	14	14
Z	15	15	15	15	18

Frontal magnet support + Magnet 8810/013
 Ordering p/n : **M9105/F26**

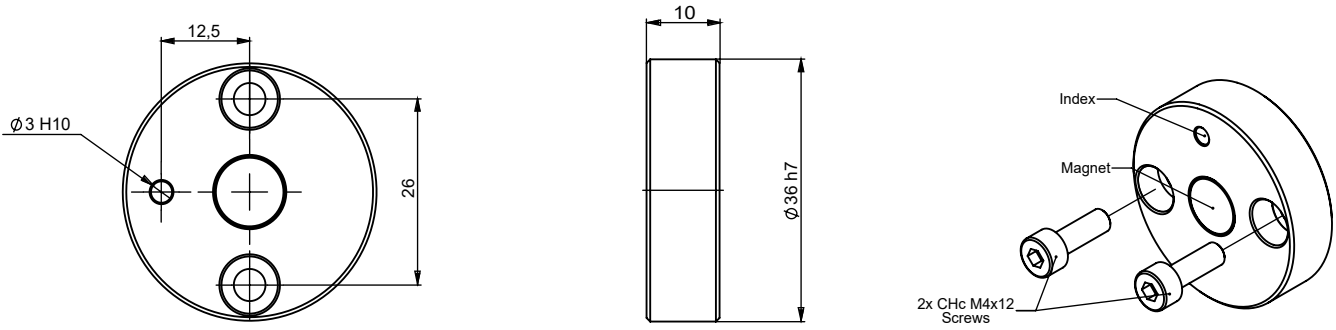

Male magnet support + Magnet 8810/013
 Ordering p/n : **M9105/M10-01**

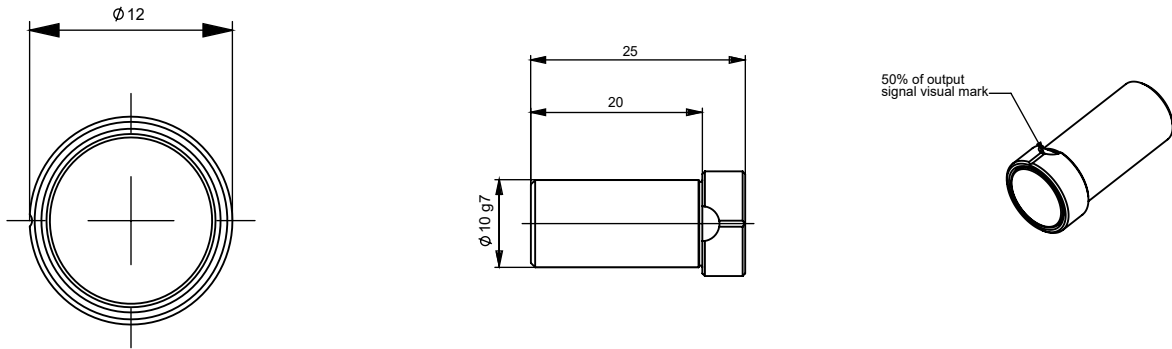

Magnet
 Ordering p/n : **8810/013**

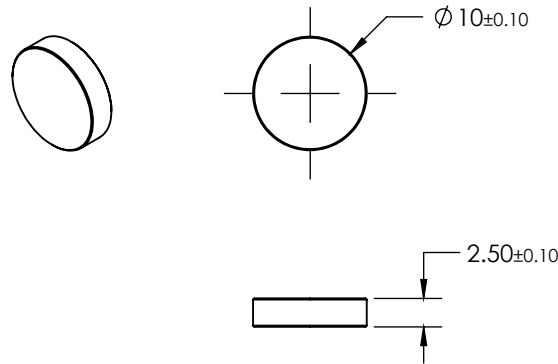

Sensata Technologies, Inc. ("Sensata") data sheets are solely intended to assist designers ("Buyers") who are developing systems that incorporate Sensata products (also referred to herein as "components"). Buyer understands and agrees that Buyer remains responsible for using its independent analysis, evaluation and judgment in designing Buyer's systems and products. Sensata data sheets have been created using standard laboratory conditions and engineering practices. Sensata has not conducted any testing other than that specifically described in the published documentation for a particular data sheet. Sensata may make corrections, enhancements, improvements and other changes to its data sheets or components without notice.

Buyers are authorized to use Sensata data sheets with the Sensata component(s) identified in each particular data sheet. HOWEVER, NO OTHER LICENSE, EXPRESS OR IMPLIED, BY ESTOPPEL OR OTHERWISE TO ANY OTHER SENSATA INTELLECTUAL PROPERTY RIGHT, AND NO LICENSE TO ANY THIRD PARTY TECHNOLOGY OR INTELLECTUAL PROPERTY RIGHT, IS GRANTED HEREIN. SENSATA DATA SHEETS ARE PROVIDED "AS IS". SENSATA MAKES NO WARRANTIES OR REPRESENTATIONS WITH REGARD TO THE DATA SHEETS OR USE OF THE DATA SHEETS, EXPRESS, IMPLIED OR STATUTORY, INCLUDING ACCURACY OR COMPLETENESS. SENSATA DISCLAIMS ANY WARRANTY OF TITLE AND ANY IMPLIED WARRANTIES OF MERCHANTABILITY, FITNESS FOR A PARTICULAR PURPOSE, QUIET ENJOYMENT, QUIET POSSESSION, AND NON-INFRINGEMENT OF ANY THIRD PARTY INTELLECTUAL PROPERTY RIGHTS WITH REGARD TO SENSATA DATA SHEETS OR USE THEREOF.

All products are sold subject to Sensata's terms and conditions of sale supplied at www.sensata.com SENSATA ASSUMES NO LIABILITY FOR APPLICATIONS ASSISTANCE OR THE DESIGN OF BUYERS' PRODUCTS. BUYER ACKNOWLEDGES AND AGREES THAT IT IS SOLELY RESPONSIBLE FOR COMPLIANCE WITH ALL LEGAL, REGULATORY AND SAFETY-RELATED REQUIREMENTS CONCERNING ITS PRODUCTS, AND ANY USE OF SENSATA COMPONENTS IN ITS APPLICATIONS, NOTWITHSTANDING ANY APPLICATIONS-RELATED INFORMATION OR SUPPORT THAT MAY BE PROVIDED BY SENSATA.

Mailing Address: Sensata Technologies, Inc., 529 Pleasant Street, Attleboro, MA 02703, USA.

CONTACT US

Americas
 +1 (800) 350 2727
sales.beisensors@sensata.com
EMEA
position-info.eu@sensata.com
 +33 (3) 88 20 8080
Asia Pacific
sales.isasia@list.sensata.com
 China +86 (21) 2306 1500
 Japan +81 (45) 277 7117
 Korea +82 (31) 601 2004
 India +91 (80) 67920890
 Rest of Asia +886 (2) 27602006
 ext 2808