

TS8242FK - 10W CW, Broadband SP4T GaN RF Switch

1.0 Features

- Low insertion loss: 0.2 @ 800MHz
- Low insertion loss: 0.3 @ 2700MHz
- High isolation: 40 @ 800MHz
- High isolation: 25 @ 2700MHz
- 40dBm CW, 45dBm Peak Power
- No external DC blocking capacitors on RF lines
- Versatile 2.6-5.25V power supply
- Operating frequency: 30 MHz to 5.0 GHz

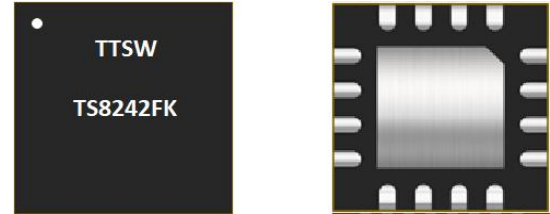

Figure 1 Device Image
(16 Pin 3×3×0.8mm QFN Package)

2.0 Applications

- Private mobile radio handsets
- Public safety handsets
- Cellular infrastructure
- Small cells
- LTE relays and microcells
- Satellite terminals



RoHS/REACH/Halogen Free Compliance

3.0 Description

The TS8242FK is a symmetrical reflective Single Pole Four Throws (SP4T) switch designed for broadband, high power switching applications. Its broadband behavior from 30 MHz to 5.0 GHz frequencies makes the TS8242FK an excellent switch for all applications requiring low insertion loss, high isolation, and high linearity within a small package size.

The TS8242FK is packaged into a compact Quad Flat No lead (QFN) 3x3mm 16 leads plastic package.

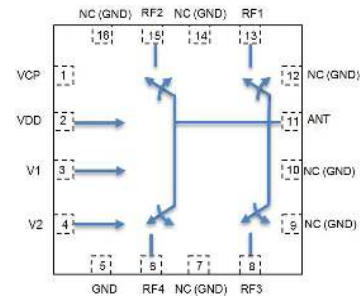

Figure 2 Function Block Diagram
(Top View)

4.0 Ordering Information

Table 1a Ordering Information

Device Part Number	Package Type	Eval Board Part Number
TS8242FK	16 Pin 3×3×0.8mm QFN	TS8242FK-EVB

Table 1b Tape and Reel Information

Form	Quantity	Reel Diameter	Reel Width
Tape and Reel	5,000	13" (330mm)	18mm

5.0 Pin Description

Table 2 Pin Definition

Pin Number	Pin Name	Description
1	VCP	Internal charge pump voltage output. Connect a 1nF capacitor to GND on this pin to improve switching time.
2	VDD	DC power supply
3	V1	Switch control input 1
4	V2	Switch control input 2
5	GND	Ground
6	RF4	RF port 4
7,9,10,12,14,16	NC	No internal connection, can be grounded
8	RF3	RF port 3
11	ANT	Antenna port
13	RF1	RF port 1
15	RF2	RF port 2

Note: The backside ground (thermal) pad of the package must be grounded directly to the ground plane of PCB with multiple vias to ensure proper operation and thermal management.

6.0 Absolute Maximum Ratings

Table 3 Absolute Maximum Ratings @ $T_A=+25^{\circ}\text{C}$ Unless Otherwise Specified

Parameter	Symbol	Value	Unit
Electrical Ratings			
Power Supply Voltage	VDD	5.5	V
Storage Temperature Range	T_{st}	-55 to +125	$^{\circ}\text{C}$
Operating Temperature Range	T_{op}	-40 to +85	$^{\circ}\text{C}$
Maximum Junction Temperature	T_J	+140	$^{\circ}\text{C}$
Maximum RF input power	RFx/ANT	40	dBm
Thermal Ratings			
Thermal Resistance (junction-to-case) – Bottom side	$R_{\theta JC}$	30	$^{\circ}\text{C/W}$
Thermal Resistance (junction-to-top)	$R_{\theta JT}$	39	$^{\circ}\text{C/W}$
Soldering Temperature	T_{SOLD}	260	$^{\circ}\text{C}$
ESD Ratings			

Human Body Model (HBM)	Level 1B	500 to <1000	V
Charged Device Model (CDM)	Level C3	≥1000	V
Moisture Rating			
Moisture Sensitivity Level	MSL	1	-

Attention:

Maximum ratings are absolute ratings. Exposure to absolute maximum rating conditions for extended periods may affect device reliability. Exceeding one or a combination of the absolute maximum ratings may cause permanent and irreversible damage to the device and/or to surrounding circuit.

7.0 Electrical Specifications

Table 4 Electrical Specifications @ $T_A=+25^{\circ}\text{C}$ Unless Otherwise Specified; $V_{DD}=+2.7\text{V}$; 50Ω Source/Load.

Parameter	Condition	Minimum	Typical	Maximum	Unit
Operating Frequency		30		5000	MHz
Insertion Loss, RFx	400MHz		0.2		dB
	800MHz		0.25	0.40	
	1.95GHz		0.3		
	4.0GHz		0.5		
Isolation ANT-RFx	400MHz		45		
	800MHz	36	40		
	1.95GHz		30		
	4.0GHz		20		
Return Loss ANT-RFx	400MHz		28		
	800MHz		24		
	1.95GHz		24		
	4.0GHz		18		
H2	800MHz, CW, Pin=40dBm		86		dBc
H3	800MHz, CW, Pin=40dBm		89		dBc
IIP3	800MHz		74		dBm
CW P0.1dB ^[1]	800MHz	40	43		dBm
Peak P0.1dB ^[1]	800MHz, Duty cycle 1%, Period 1 mS	45	48		dBm
Switching Time	50% ctrl to 10/90% of the RF value is settled. C1=1nF (refer to Figure 3)		0.6		μs
Control Voltage	Power supply VDD	2.6	3.3	5.25	V
	All control pins high, V_{ih}	1.0	3.3	5.25	V
	All control pins low, V_{il}	-0.3		0.5	V
Control Current	All control pins low, I_{il}		0		μA
	All control pins high, I_{ih}			7.5	μA
Current Consumption, I_{DD}	Active mode		170	210	μA

Note:

[1] P0.1dB is a figure of merit.

[2] No external DC blocking capacitors required on RF pins unless DC voltage is applied on a RF pin.

8.0 Switch Truth Table

Table 5 Switch Truth Table

V1	V2	Active RF Path
0	0	ANT-RF1
1	0	ANT-RF2
0	1	ANT-RF3
1	1	ANT-RF4

Attention:

- [1] VDD should be applied first before V1 and V2, otherwise may cause damage to the device.
- [2] There are internal pull-downs to ground on both V1 and V2 control pins, the state at start-up without any control voltage applied will be ANT-RF1 ON.

9.0 Evaluation Board (no match)

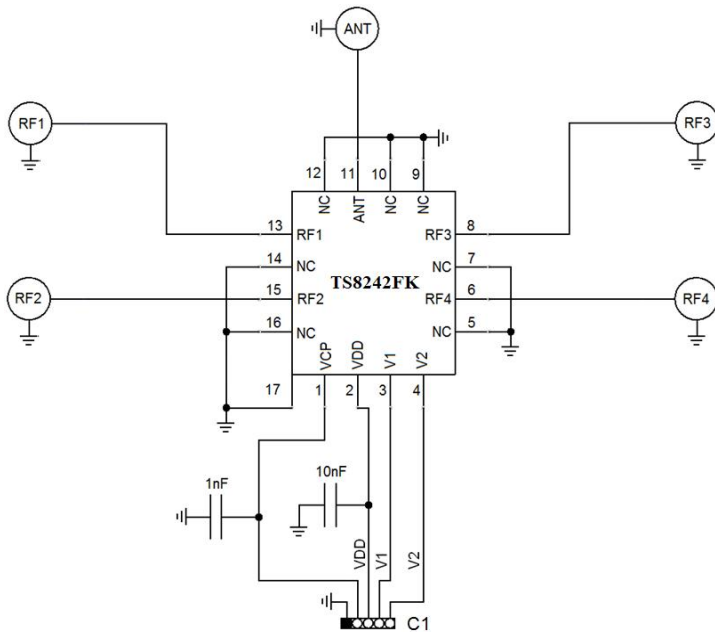

Figure 3 Evaluation Board Schematic

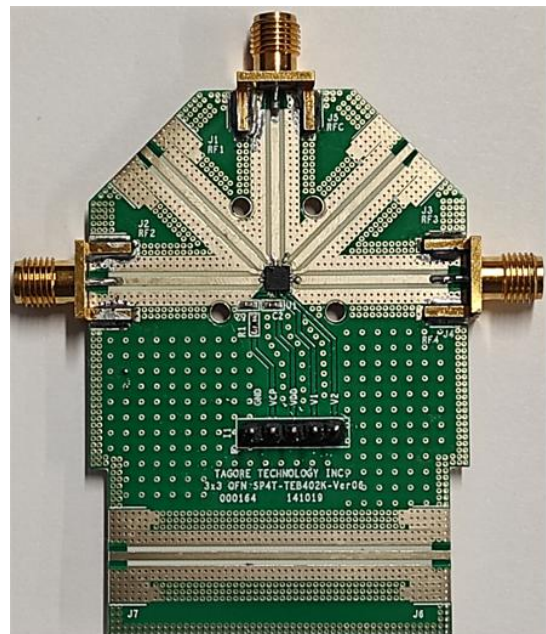

Figure 4 Evaluation Board Image

Attention:

- [1] 17 refers to the center pad of the device.
- [2] The purpose of connection between VCP and connector C1 is to monitor VCP, do not apply external voltage to VCP.
- [3] matched EVB has a series 1nH inductor, and then a shunt 0.3pF capacitor at TS8242FK Ant port.

10.0 Typical Characteristics(matched)

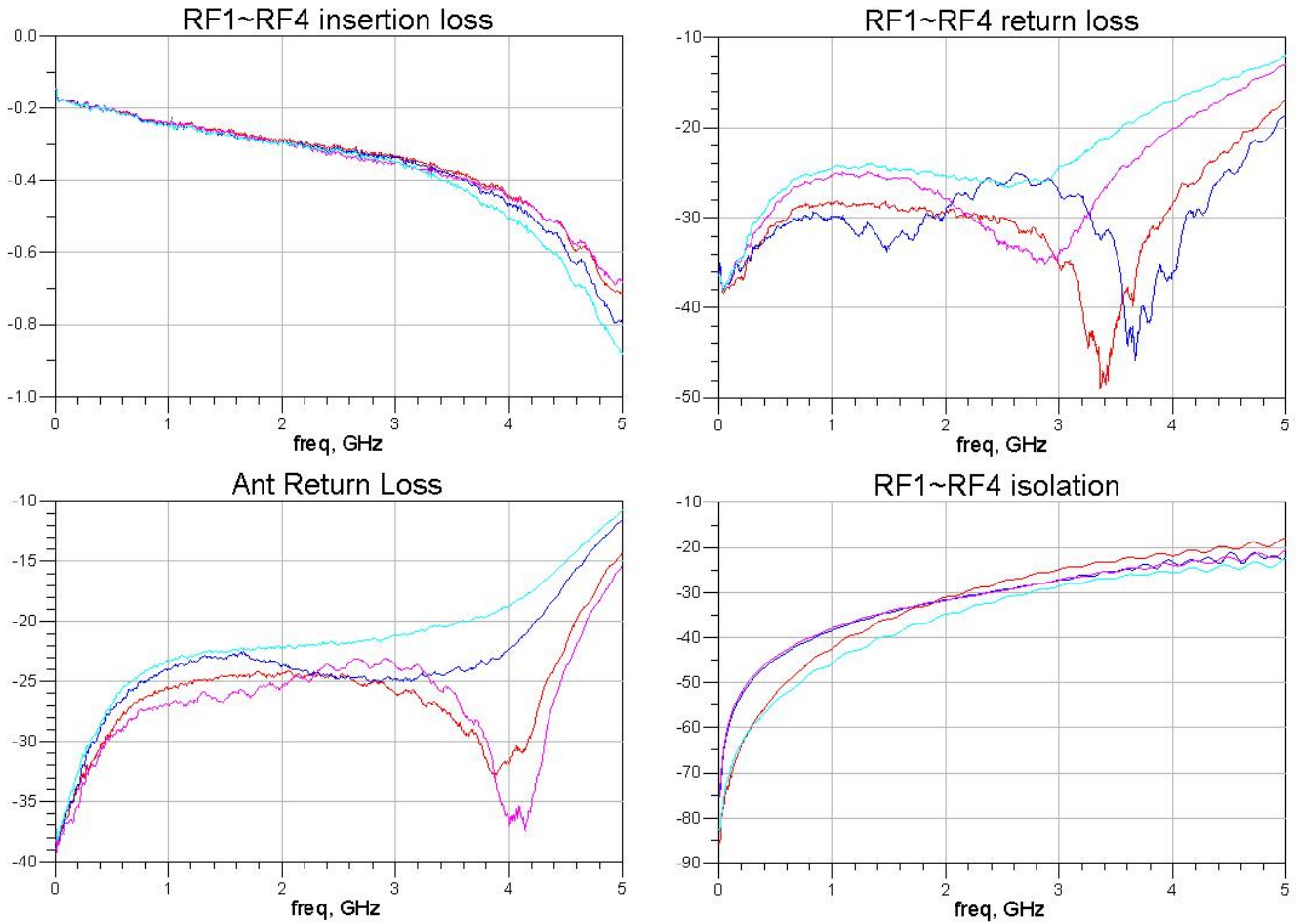

Figure 5 Typical Characteristics of TS8242FK

11.0 Device Package Information

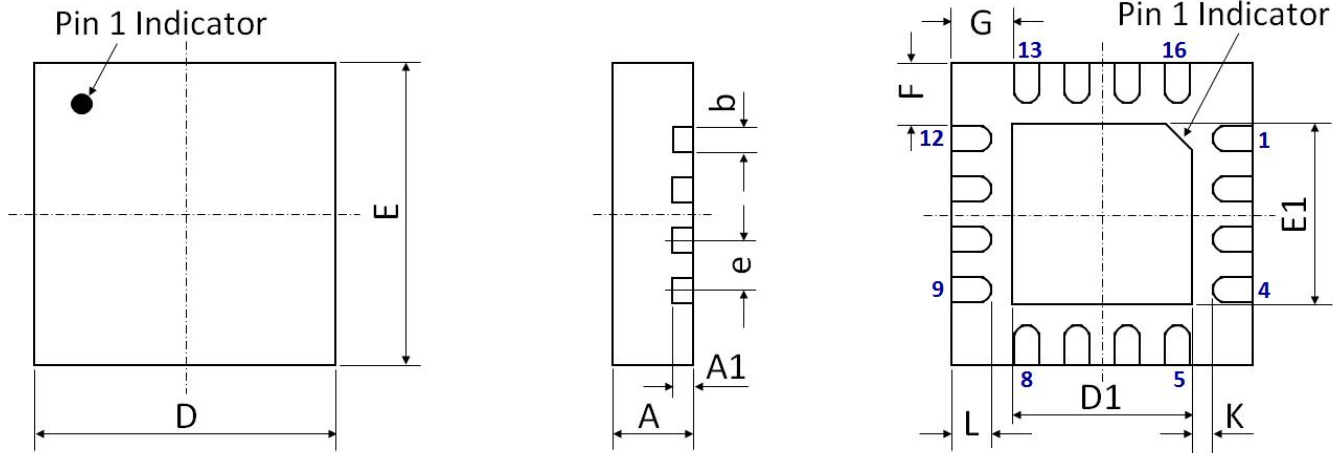

Figure 6 Device Package Drawing
(All dimensions are in mm)

Table 6 Device Package Dimensions

Dimension (mm)	Value (mm)	Tolerance (mm)	Dimension (mm)	Value (mm)	Tolerance (mm)
A	0.80	±0.05	E	3.00 BSC	±0.05
A1	0.203	±0.02	E1	1.70	±0.05
b	0.25	±0.05	F	0.625	±0.05
D	3.00 BSC	±0.05	G	0.625	±0.05
D1	1.70	±0.05	K	0.25	±0.05
e	0.50 BSC	±0.05	L	0.40	±0.05

Note: Lead finish: Pure Sn without underlayer; Thickness: 7.5µm ~ 20µm (Typical 10µm ~ 12µm)

Attention:

Please refer to application notes [TN-001](#) and [TN-002](#) at <http://www.tagoretech.com> for PCB and soldering related guidelines.

13.0 PCB Stencil Design

Guidelines:

- [1] Laser-cut, stainless steel stencil is recommended with electro-polished trapezoidal walls to improve the paste release.
- [2] Stencil thickness is recommended to be 125µm.

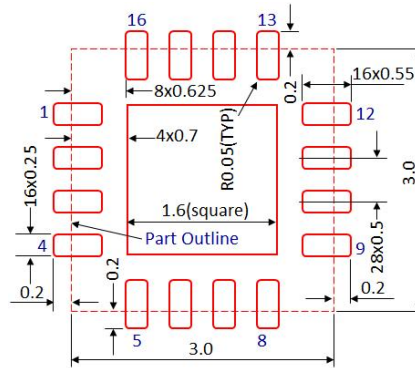

Figure 10 Stencil Openings
(Dimensions are in mm)

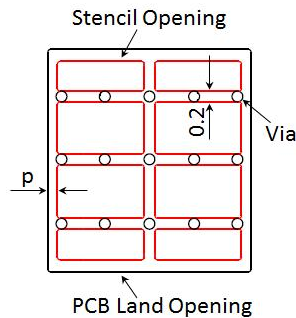

Figure 11 Stencil Openings Shall not Cover Via Areas If Possible
(Dimensions are in mm)

14.0 Tape and Reel Information

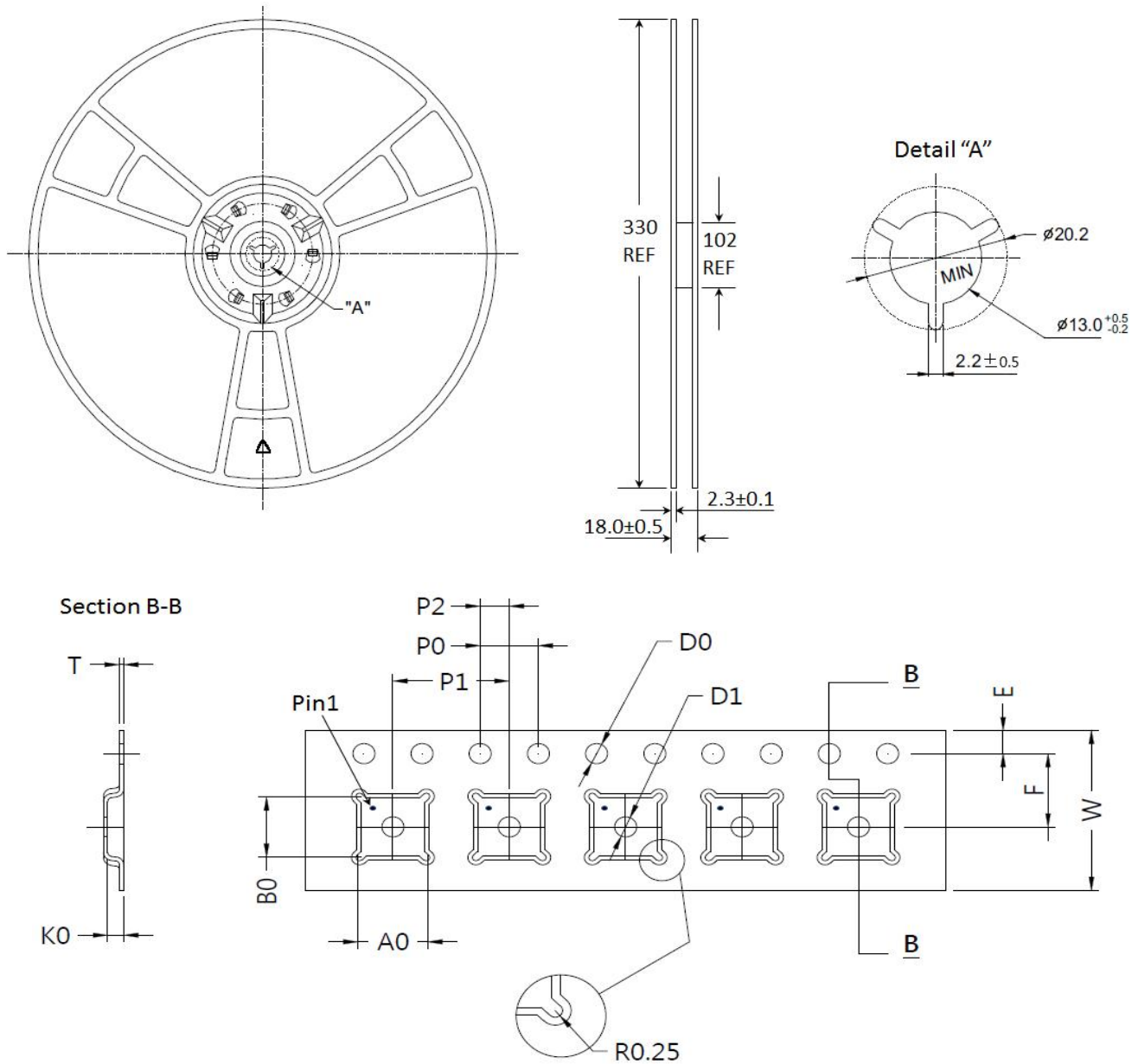

Figure 12 Tape and Reel Drawing

Table 7 Tape and Reel Dimensions

Dimension (mm)	Value (mm)	Tolerance (mm)	Dimension (mm)	Value (mm)	Tolerance (mm)
A0	3.35	±0.10	K0	1.10	±0.10
B0	3.35	±0.10	P0	4.00	±0.10
D0	1.50	+0.10/-0.00	P1	8.00	±0.10
D1	1.50	+0.10/-0.00	P2	2.00	±0.05
E	1.75	±0.10	T	0.30	±0.05
F	5.50	±0.05	W	12.00	±0.30

Edition Revision 1.1 - 2022-02-16

Published by

Tagore Technology Inc.
5 East College Drive, Suite 200
Arlington Heights, IL 60004, USA

©2018 All Rights Reserved

Legal Disclaimer

The information provided in this document shall in no event be regarded as a guarantee of conditions or characteristics. Tagore Technology assumes no responsibility for the consequences of the use of this information, nor for any infringement of patents or of other rights of third parties which may result from the use of this information. No license is granted by implication or otherwise under any patent or patent rights of Tagore Technology. The specifications mentioned in this document are subject to change without notice.

Information

For further information on technology, delivery terms and conditions and prices, please contact Tagore Technology: support@tagoretech.com.