

Evaluation Board for the **ADP2311**, Dual, 1 A, 18 V Synchronous Step-Down Regulator with Fail-Safe Voltage Monitoring

FEATURES

- Input voltage: 4.5 V to 18 V**
- ±1.0% output accuracy**
- Integrated MOSFET: 110 mΩ/60 mΩ typical**
- Continuous output current: 1 A/1 A**
- Power fail comparator generates warning**
- Power-on reset with programmable delay timer**
- Adjustable voltage monitor for power-down**
- Watchdog refresh input**
- Dual phase with 180° out of phase operation**
- Fixed switching frequency: 300 kHz**
- Internal compensation and soft start**
- Stable with low effective series resistance (ESR) output ceramic capacitors**
- Precision enable input**
- Power feedback during power off**
- Undervoltage lockout (UVLO), overcurrent protection (OCP), overvoltage protection (OVP), and thermal shutdown (TSD)**

GENERAL DESCRIPTION

The **ADP2311** evaluation board is a complete, dual, 1 A step-down regulator solution that allows users to evaluate the performance of the **ADP2311** with a near ideal printed circuit board (PCB) layout.

The outputs of the **ADP2311** evaluation board are preset to 1.2 V and 3.3 V for Channel 1 and Channel 2, respectively. The VIN threshold of the power fail input is set at 8.99 V. Different output and power fail input voltages can be achieved by changing the appropriate passive components.

Full details on the **ADP2311** dual regulator are provided in the **ADP2311** data sheet, available from Analog Devices, Inc., which should be consulted in conjunction with this user guide.

ADP2311 EVALUATION BOARD

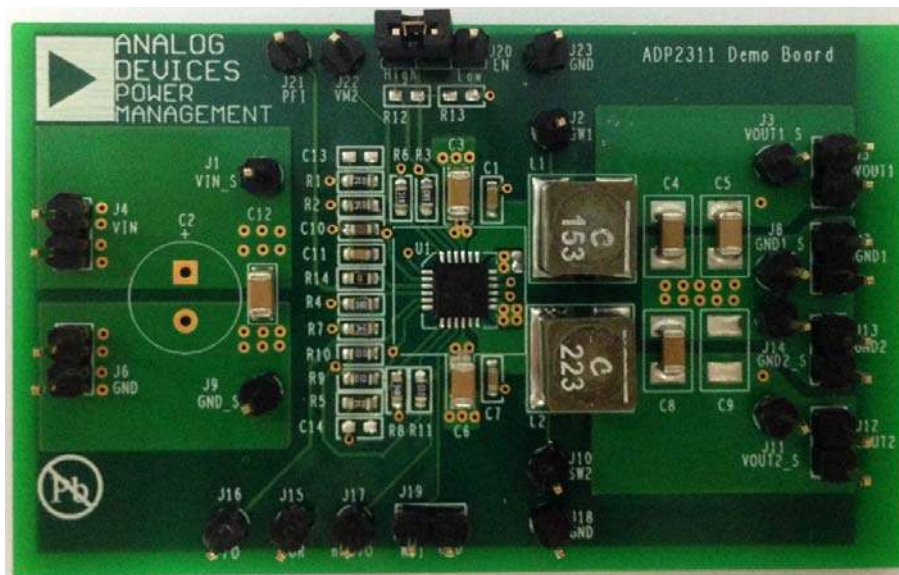

Figure 1.

TABLE OF CONTENTS

Features	1	Evaluation Board Schematic and Artwork.....	5
General Description	1	ADP2311 Evaluation Board Schematic.....	5
ADP2311 Evaluation Board	1	PCB Layout	6
Revision History	2	Ordering Information.....	8
Using the Evaluation Board.....	3	Bill of Materials.....	8
Powering Up the Evaluation Board.....	3		
Measuring Evaluation Board Performance	3		
Modifying the Evaluation Board.....	4		

REVISION HISTORY

3/14—Revision 0: Initial Version

USING THE EVALUATION BOARD

POWERING UP THE EVALUATION BOARD

The ADP2311 evaluation board is supplied fully assembled and tested. Before applying power to the evaluation board, follow the procedures in this section.

Jumper J20 Setting (Enable)

Jumper J20 is used to control the ADP2311. Use one of the following methods to enable or to disable the device:

- To enable the ADP2311, short the middle pin of J20 (EN) to high.
- To disable the ADP2311, short the middle pin of J20 (EN) to low.

Input Power Source

If the input power source includes a current meter, use that meter to monitor the input current. Connect the positive terminal of the power source to J4 (VIN) of the evaluation board, and connect the negative terminal of the power source to J6 (GND) of the evaluation board.

If the power source does not include a current meter, connect a current meter in series with the input source voltage. Connect the positive lead (+) of the power source to the positive (+) ammeter terminal, the negative lead (–) of the power source to J6 (GND), and the negative lead (–) of the ammeter to J4 (VIN).

Output Load

Before connecting the load, ensure that the board is turned off. Connect an electronic load or resistor to set the load current.

To connect a load to the output of Channel 1, connect the positive terminal of the load to J5 (VOUT1) of the evaluation board and connect the negative terminal of the load to J7 (GND).

To connect a load to the output of Channel 2, connect the positive terminal of the load to J12 (VOUT2) of the evaluation board and connect the negative terminal of the load to J13 (GND).

Input and Output Voltmeter

Measure the input and output voltages using voltmeters. Make sure that the voltmeters are connected to the appropriate terminals of the evaluation board and not to the load or power source. If the voltmeters are not connected directly to the evaluation board, the measured voltages are incorrect due to the voltage drop across the leads and/or connections between the evaluation board, the power source, and/or the load.

To measure the input voltage, connect the positive terminal of the voltmeter to J1 (VIN_S) and the negative terminal to J9 (GND_S). Likewise, to measure the output voltage, connect the positive terminal of the voltmeter to J3 (VOUT1_S) or J11 (VOUT2_S) and the negative terminal to J8 (GND1_S) or J14 (GND2_S).

Turning On the Evaluation Board

When the power source and load are connected to the evaluation board, it can be powered for operation.

To turn on the evaluation board, perform the following steps:

1. Ensure that the power source voltage is >4.5 V and <18 V.
2. Ensure that EN is high and monitor the output voltage.
3. Turn on the load, check that it is drawing the proper load current, and verify that the output voltage maintains its regulation.

MEASURING EVALUATION BOARD PERFORMANCE

Measuring the Switching Waveform

To observe the switching waveform with an oscilloscope, place the oscilloscope probe tip at Test Point J2 (SW1) and J10 (SW2) with the probe ground at GND. Set the scope to dc with the appropriate voltage and time divisions. The switching waveform must alternate approximately between 0 V and the input voltage.

Measuring Load Regulation

Load regulation can be tested by observing the change in the output voltage with increasing output load current.

Measuring Line Regulation

Vary the input voltage and examine the change in the output voltage with a fixed output current.

Line Transient Response

Generate a step input voltage change and observe the behavior of the output voltage using an oscilloscope.

Load Transient Response

Generate a load current transient at the output and observe the output voltage response using an oscilloscope. Attach the current probe to the wire between the output and the load to capture the current transient waveform.

Measuring Efficiency

The efficiency, η , is measured by comparing the input power with the output power.

$$\eta = \frac{V_{OUT} \times I_{OUT}}{V_{IN} \times I_{IN}}$$

Measure the input and output voltages as close as possible to the input and output capacitors to reduce the effect of voltage drop.

Measuring Inductor Current

The inductor current can be measured by removing one end of the inductor from its pad and by connecting a current loop in series. A current probe can be connected onto this wire.

Measuring Output Voltage Ripple

To observe the output voltage ripple, place the oscilloscope probe across the output capacitor with the probe ground lead connected to the negative (-) capacitor terminal and the probe tip placed at the positive (+) capacitor terminal. Set the oscilloscope to ac, 10 mV/division, 2 μs/division time base, and 20 MHz bandwidth.

A standard oscilloscope probe has a long wire ground clip. For high frequency measurements, this ground clip picks up high frequency noise and injects it into the measured output ripple. Figure 2 shows an easy way to measure the output ripple properly. It requires removing the oscilloscope probe sheath and wrapping an unshielded wire around the oscilloscope probe. By keeping the ground length of the oscilloscope probe as short as possible, the true ripple can be measured.

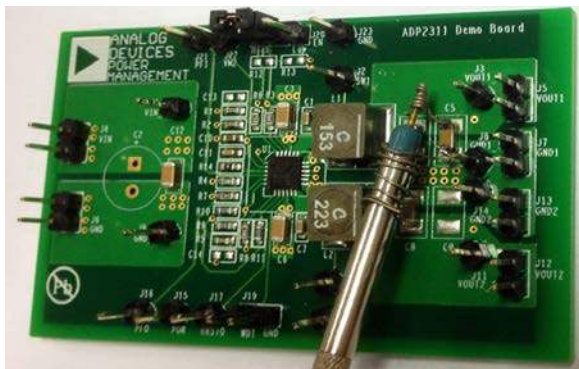

Figure 2. Measuring Output Voltage Ripple

MODIFYING THE EVALUATION BOARD

To modify the ADP2311 evaluation board configuration, unsolder and/or replace/remove the appropriate passive components or jumpers on the board.

Changing the Output Voltages

The output voltage setpoints of the ADP2311 can be changed by replacing the R1, R2, R5, and R8 resistors with the resistor values shown in Table 1.

Table 1. Resistive Divider for Various Output Voltages

V _{OUT} (V)	R1/R5, ±1% (kΩ)	R2/R8, ±1% (kΩ)
1.0	10	15
1.2	10	10
1.5	15	10
1.8	20	10
2.5	47.5	15
3.3	10	2.21
5.0	22	3

To limit the output voltage accuracy degradation due to the FBx bias current (0.1 μA maximum) to less than 0.5% (maximum), ensure that the bottom divider string resistors, R2 and R8, is less than 30 kΩ.

The top resistors, R1 and R5, value is calculated using the following equations:

For Channel 1,

$$R1 = R2 \times \left(\frac{V_{OUT1} - 0.6 \text{ V}}{0.6 \text{ V}} \right)$$

For Channel 2,

$$R5 = R8 \times \left(\frac{V_{OUT2} - 0.6 \text{ V}}{0.6 \text{ V}} \right)$$

When the output voltage of Channel 1 is changed, the values of the inductor (L1) and the output capacitors (C4 and C5) must be recalculated and changed to ensure stable operation (see the ADP2311 data sheet for details on external component selection). Likewise, if the output voltage of Channel 2 is changed, the values of the inductor (L2) and the output capacitors (C8 and C9) must be recalculated and changed.

Changing the VIN Threshold of Power Fail (PFI)

The evaluation board sets the V_{PFI_RISING} at 8.99 V and the V_{PFI_FALLING} at 8.61 V. It can be changed with different R4 and R7 value.

Using the following equation to calculate the R4 and R7:

$$V_{PFI_RISING} = 0.6 \text{ V} \times \frac{R4 + R7}{R7}$$

$$V_{PFI_FALLING} = 0.575 \text{ V} \times \frac{R4 + R7}{R7}$$

Changing the VIN Threshold of Voltage Monitoring (VM2)

The evaluation board sets the V_{VM2_RISING} at 5.41 V and the V_{VM2_FALLING} at 5 V. It can be changed with different R3 and R6 value.

Using the following equation to calculate R3 and R6:

$$V_{VM2_RISING} = 0.65 \text{ V} \times \frac{R3 + R6}{R6}$$

$$V_{VM2_FALLING} = 0.6 \text{ V} \times \frac{R3 + R6}{R6}$$

EVALUATION BOARD SCHEMATIC AND ARTWORK

ADP2311 EVALUATION BOARD SCHEMATIC

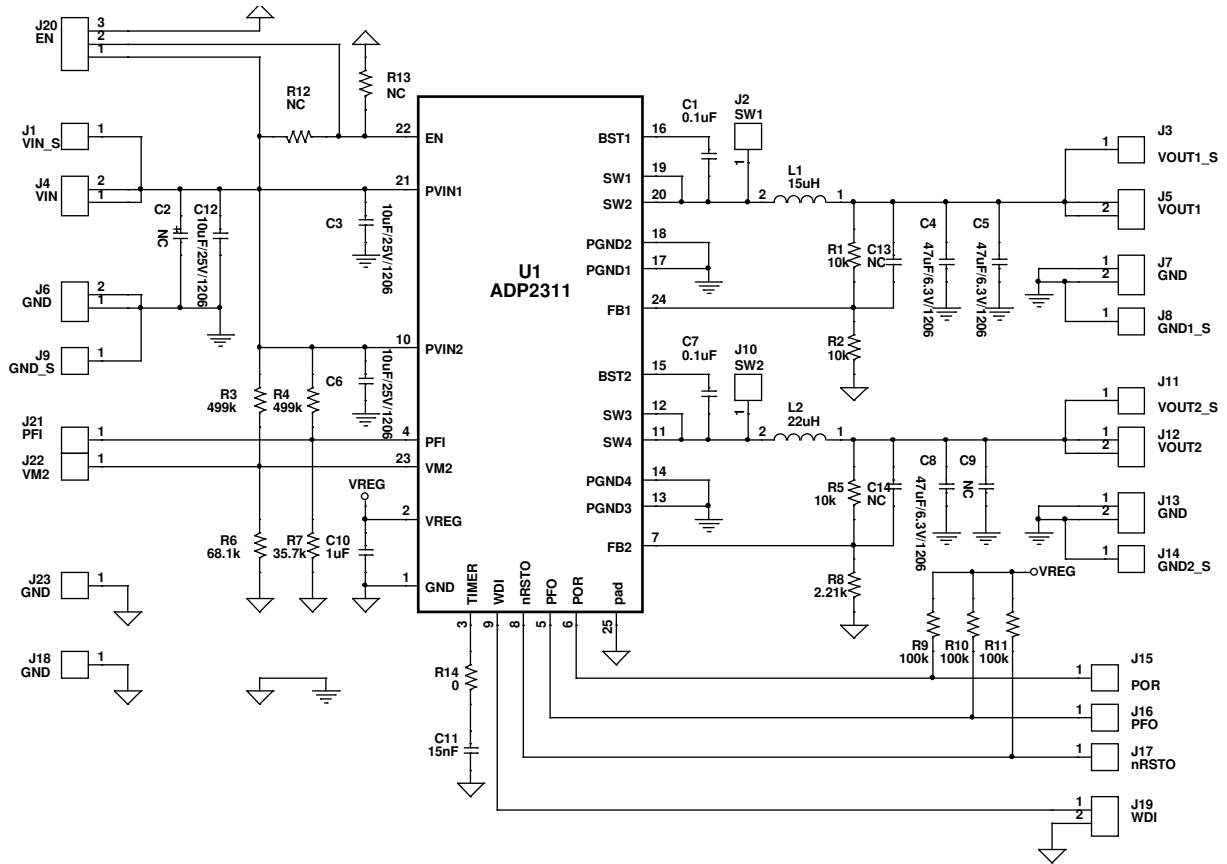

Figure 3. Evaluation Board Schematic for the ADP2311

11995-003

PCB LAYOUT

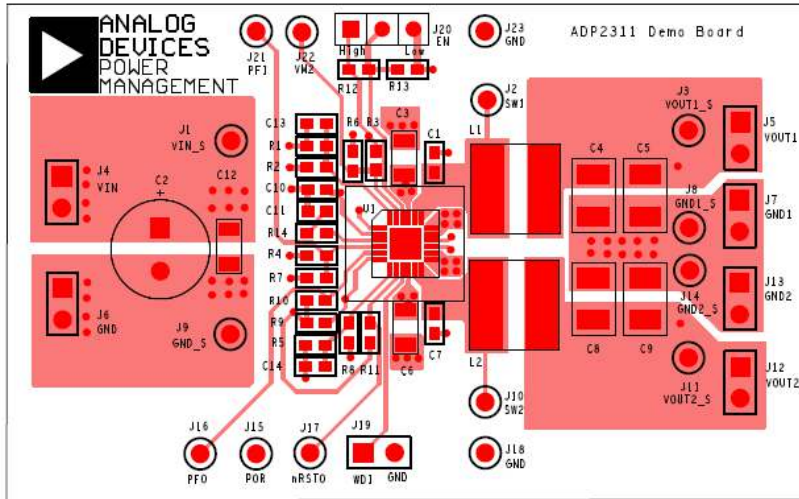

Figure 4. ADP2311 Evaluation Board Layer 1, Component Side

11995-004

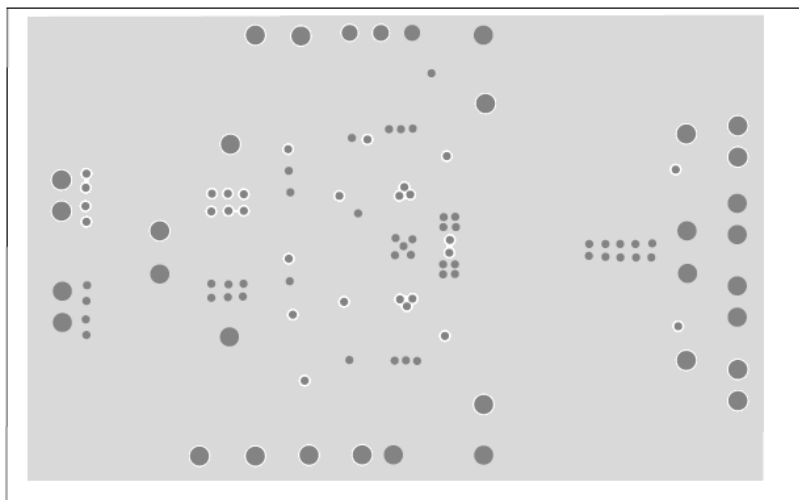
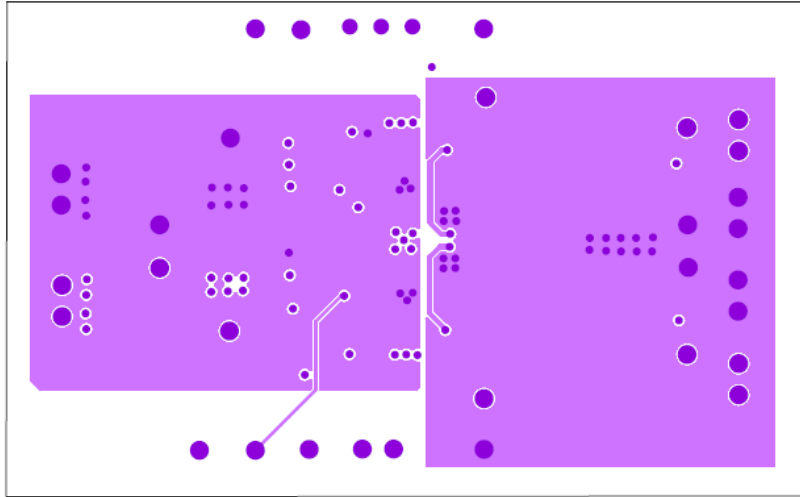

Figure 5. ADP2311 Evaluation Board Layer 2, Ground Plane

11995-005



11995-006

Figure 6. ADP2311 Evaluation Board Layer 3, Power Plane

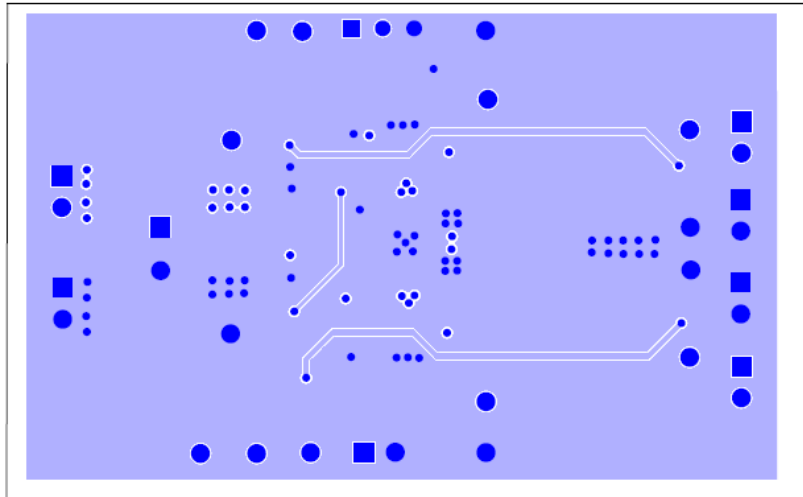

11995-007

Figure 7. ADP2311 Evaluation Board Layer 4, Bottom Side

ORDERING INFORMATION

BILL OF MATERIALS

Table 2.

Qty	Reference Designator	Description	Part Number/Vendor
2	C1, C7	0.1 μ F, 50 V, capacitor, 0603	GRM188F51H104ZA01/Murata
1	C2	Optional, capacitor	Optional
3	C3, C6, C12	10 μ F, 25 V, capacitor, 1206	GRM31CR61E106KA12/Murata
3	C4, C5, C8	47 μ F, 6.3 V, capacitor, 1206	GRM31CR60J476ME19L/Murata
1	C10	1 μ F, 16 V, capacitor, 0603	GRM188F51C105ZA01/Murata
1	C11	15 nF, 50 V, capacitor, 0603	GRM188F51H153ZA01/Murata
1	C9	Optional, capacitor, 1206	Optional
2	C13, C14	Optional, capacitor, 0603	Optional
1	L1	Inductor, L = 15 μ H, I_{RAT} = 5.8 A, DCR = 43.75 m Ω	XAL6060-153ME/CoilCraft
1	L2	Inductor, L = 22 μ H, I_{RAT} = 5.6 A, DCR = 60.63 m Ω	XAL6060-223ME/CoilCraft
3	R1, R2, R5	10 k Ω , 1%, resistor, 0603	CRCW060310K0FKEA/Vishay Dale
2	R3, R4	499 k Ω , 1%, resistor, 0603	CRCW0603499KFKEA/Vishay Dale
1	R6	68.1 k Ω , 1%, resistor, 0603	CRCW060368K1FKEA/Vishay Dale
1	R7	35.7 k Ω , 1%, resistor, 0603	CRCW060335K7FKEA/Vishay Dale
1	R8	2.21 k Ω , 1%, resistor, 0603	CRCW06032K21FKEA/Vishay Dale
3	R9, R10, R11	100 k Ω , 1%, resistor, 0603	CRCW0603100KFKEA/Vishay Dale
2	R12, R13	Optional, resistor, 0603	Optional
1	R14	0 Ω , resistor, 0603	CRCW06030000Z0EA/Vishay Dale
1	U1	Dual 1 A, 18 V synchronous, step-down regulator with failsafe voltage monitoring, 24-lead LFCSP_WQ	ADP2311ACPZ-1-R7/Analog Devices
15	J1, J2, J3, J8, J9, J10, J11, J14, J15, J16, J17, J18, J21, J22, J23	Test point, 2.54 mm pitch SIL vertical PC tail pin header, 6.1 mm mating pin height, tin, SIP1	M20-9990245/Harwin
7	J4, J5, J6, J7, J12, J13, J19	Connector, 2.54 mm pitch SIL vertical PC tail pin header, 6.1 mm mating pin height, tin, 2-way, SIP2	M20-9990245/Harwin
1	J20	Jumper, 0.1-inch header, 3-way, SIP3	M20-9990346/Harwin

**ESD Caution**

ESD (electrostatic discharge) sensitive device. Charged devices and circuit boards can discharge without detection. Although this product features patented or proprietary protection circuitry, damage may occur on devices subjected to high energy ESD. Therefore, proper ESD precautions should be taken to avoid performance degradation or loss of functionality.

Legal Terms and Conditions

By using the evaluation board discussed herein (together with any tools, components documentation or support materials, the "Evaluation Board"), you are agreeing to be bound by the terms and conditions set forth below ("Agreement") unless you have purchased the Evaluation Board, in which case the Analog Devices Standard Terms and Conditions of Sale shall govern. Do not use the Evaluation Board until you have read and agreed to the Agreement. Your use of the Evaluation Board shall signify your acceptance of the Agreement. This Agreement is made by and between you ("Customer") and Analog Devices, Inc. ("ADI"), with its principal place of business at One Technology Way, Norwood, MA 02062, USA. Subject to the terms and conditions of the Agreement, ADI hereby grants to Customer a free, limited, personal, temporary, non-exclusive, non-sublicensable, non-transferable license to use the Evaluation Board FOR EVALUATION PURPOSES ONLY. Customer understands and agrees that the Evaluation Board is provided for the sole and exclusive purpose referenced above, and agrees not to use the Evaluation Board for any other purpose. Furthermore, the license granted is expressly made subject to the following additional limitations: Customer shall not (i) rent, lease, display, sell, transfer, assign, sublicense, or distribute the Evaluation Board; and (ii) permit any Third Party to access the Evaluation Board. As used herein, the term "Third Party" includes any entity other than ADI, Customer, their employees, affiliates and in-house consultants. The Evaluation Board is NOT sold to Customer; all rights not expressly granted herein, including ownership of the Evaluation Board, are reserved by ADI. CONFIDENTIALITY. This Agreement and the Evaluation Board shall all be considered the confidential and proprietary information of ADI. Customer may not disclose or transfer any portion of the Evaluation Board to any other party for any reason. Upon discontinuation of use of the Evaluation Board or termination of this Agreement, Customer agrees to promptly return the Evaluation Board to ADI. ADDITIONAL RESTRICTIONS. Customer may not disassemble, decompile or reverse engineer chips on the Evaluation Board. Customer shall inform ADI of any occurred damages or any modifications or alterations it makes to the Evaluation Board, including but not limited to soldering or any other activity that affects the material content of the Evaluation Board. Modifications to the Evaluation Board must comply with applicable law, including but not limited to the RoHS Directive. TERMINATION. ADI may terminate this Agreement at any time upon giving written notice to Customer. Customer agrees to return to ADI the Evaluation Board at that time. LIMITATION OF LIABILITY. THE EVALUATION BOARD PROVIDED HEREUNDER IS PROVIDED "AS IS" AND ADI MAKES NO WARRANTIES OR REPRESENTATIONS OF ANY KIND WITH RESPECT TO IT. ADI SPECIFICALLY DISCLAIMS ANY REPRESENTATIONS, ENDORSEMENTS, GUARANTEES, OR WARRANTIES, EXPRESS OR IMPLIED, RELATED TO THE EVALUATION BOARD INCLUDING, BUT NOT LIMITED TO, THE IMPLIED WARRANTY OF MERCHANTABILITY, TITLE, FITNESS FOR A PARTICULAR PURPOSE OR NON-INFRINGEMENT OF INTELLECTUAL PROPERTY RIGHTS. IN NO EVENT WILL ADI AND ITS LICENSORS BE LIABLE FOR ANY INCIDENTAL, SPECIAL, INDIRECT, OR CONSEQUENTIAL DAMAGES RESULTING FROM CUSTOMER'S POSSESSION OR USE OF THE EVALUATION BOARD, INCLUDING BUT NOT LIMITED TO LOST PROFITS, DELAY COSTS, LABOR COSTS OR LOSS OF GOODWILL. ADI'S TOTAL LIABILITY FROM ANY AND ALL CAUSES SHALL BE LIMITED TO THE AMOUNT OF ONE HUNDRED US DOLLARS (\$100.00). EXPORT. Customer agrees that it will not directly or indirectly export the Evaluation Board to another country, and that it will comply with all applicable United States federal laws and regulations relating to exports. GOVERNING LAW. This Agreement shall be governed by and construed in accordance with the substantive laws of the Commonwealth of Massachusetts (excluding conflict of law rules). Any legal action regarding this Agreement will be heard in the state or federal courts having jurisdiction in Suffolk County, Massachusetts, and Customer hereby submits to the personal jurisdiction and venue of such courts. The United Nations Convention on Contracts for the International Sale of Goods shall not apply to this Agreement and is expressly disclaimed.