

THIS DRAWING IS UNPUBLISHED. RELEASED FOR PUBLICATION
 © COPYRIGHT - By - ALL RIGHTS RESERVED.

LOC		DIST		REVISIONS			
P	LTR	DESCRIPTION	DATE	DWN	APVD		
	A	PRODUCTION RELEASE PER ECO-13-014747	4 SEP 13	CT	RL		

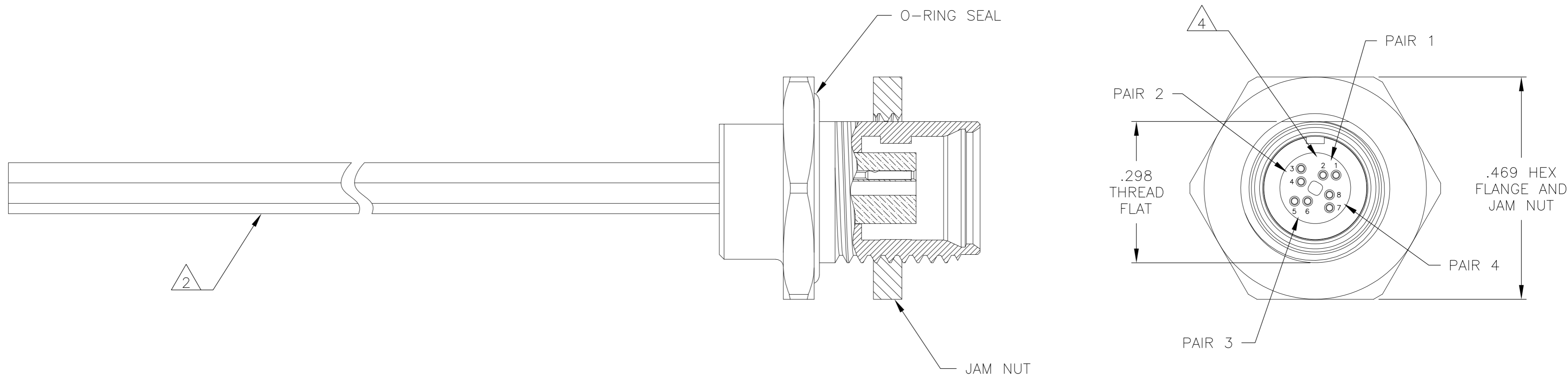
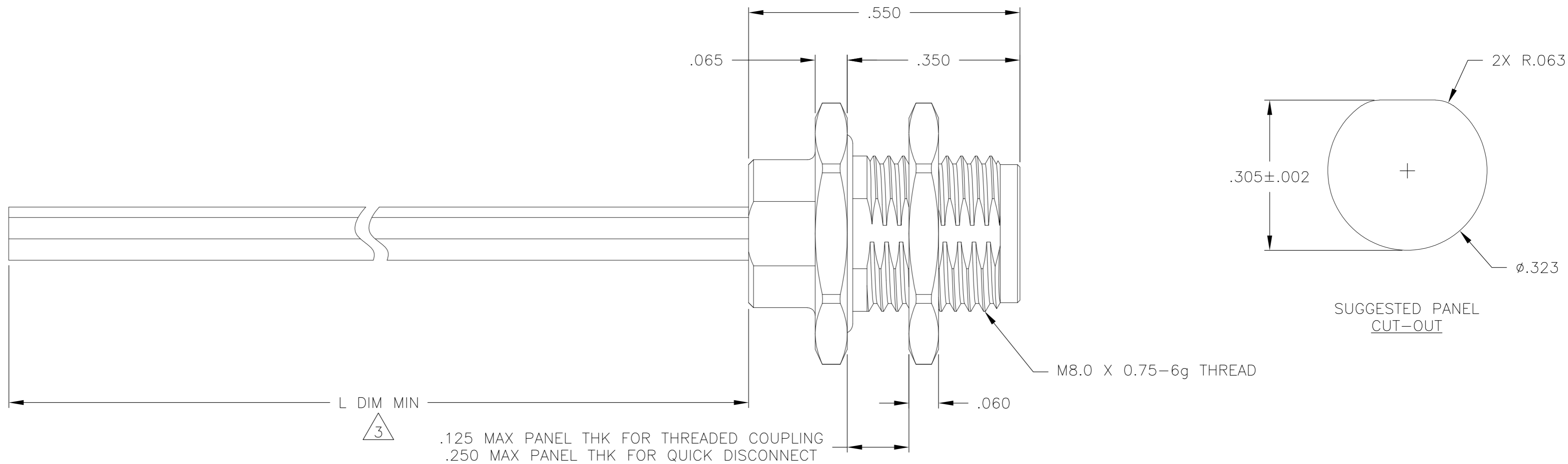

- 1 CONNECTOR BODY AND JAM NUT MATERIAL:
6061-T6 ALUMINUM, ELECTROLESS NICKEL PLATED PER SAE-AMS-C-26074 OR SAE-AMS-2404
INSULATOR MATERIAL: LIQUID CRYSTAL POLYMER (LCP) PER ASTM D5138
O-RING MATERIAL: FLUOROSILICONE PER SAE-AMS-R-25988

- 2 TERMINATED WITH MADISON CABLE 30 AWG 10G TURBO TWIN PAIR
- 3 CABLE LENGTH IS AS INDICATED IN THE CORRESPONDING NANONICS PART NUMBER
- 4 CAVITY POSITIONS ARE SHOWN FOR REFERENCE ONLY AND ARE NOT MARKED ON THE PART
- 5 LUBRICATE O-RING WITH PARKER SUPER-O-LUBE PRIOR TO INSTALLATION
- 6 REFERENCE TE PRODUCT SPECIFICATION 108-32048 FOR PRODUCT DETAILS AND PERFORMANCE

THIS DRAWING IS A CONTROLLED DOCUMENT.		DWN	M STORRY	31 JUL 2012		TE Connectivity		
DIMENSIONS: INCHES		CHK	M STORRY	31 JUL 2012		NAME		
TOLERANCES UNLESS OTHERWISE SPECIFIED:		APVD	M STORRY	31 JUL 2012		RECEPTACLE ASSEMBLY, CIRCULAR, REAR PANEL MOUNT, THREADED COUPLING/QUICK DISCONNECT, METAL, 8 POS, 10GbE, CeeLok FAS-T Nano Circular		
0 PLC ± - 1 PLC ± - 2 PLC ± .010 3 PLC ± .005 4 PLC ± - ANGLES ± 1°		PRODUCT SPEC				SIZE	CAGE CODE	DRAWING NO
MATERIAL SEE NOTES		FINISH	SEE NOTES		WEIGHT	A2 0PJN9 C=1925258		
CUSTOMER DRAWING					SCALE	6:1	SHEET 1 of 1	
					REV	A		