

MEMS digital output motion sensor: ultra-low-power high-performance 3-axis "nano" accelerometer

Datasheet - production data

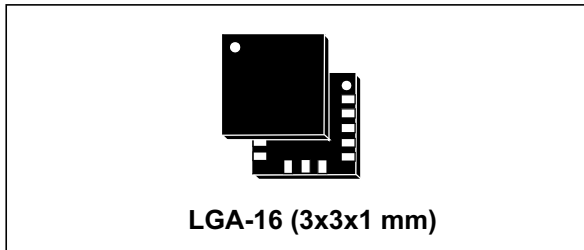

Features

- Wide supply voltage, 1.71 V to 3.6 V
- Independent IO supply (1.8 V) and supply voltage compatible
- Ultra-low-power mode consumption down to 2 μ A
- $\pm 2g/\pm 4g/\pm 8g/\pm 16g$ dynamically selectable full scale
- I²C/SPI digital output interface
- 16-bit data output
- 2 independent programmable interrupt generators for free-fall and motion detection
- 6D/4D orientation detection
- Free-fall detection
- Motion detection
- Embedded temperature sensor
- Embedded self-test
- Embedded 32 levels of 16-bit data output FIFO
- 10000 g high shock survivability
- ECOPACK[®], RoHS and "Green" compliant

Applications

- Motion activated functions
- Free-fall detection
- Click/double-click recognition
- Intelligent power saving for handheld devices
- Pedometers

- Display orientation
- Gaming and virtual reality input devices
- Impact recognition and logging
- Vibration monitoring and compensation

Description

The LIS3DH is an ultra-low-power high-performance three-axis linear accelerometer belonging to the "nano" family, with digital I²C/SPI serial interface standard output. The device features ultra-low-power operational modes that allow advanced power saving and smart embedded functions.

The LIS3DH has dynamically user-selectable full scales of $\pm 2g/\pm 4g/\pm 8g/\pm 16g$ and is capable of measuring accelerations with output data rates from 1 Hz to 5.3 kHz. The self-test capability allows the user to check the functioning of the sensor in the final application. The device may be configured to generate interrupt signals using two independent inertial wake-up/free-fall events as well as by the position of the device itself. Thresholds and timing of interrupt generators are programmable by the end user on the fly. The LIS3DH has an integrated 32-level first-in, first-out (FIFO) buffer allowing the user to store data in order to limit intervention by the host processor. The LIS3DH is available in small thin plastic land grid array package (LGA) and is guaranteed to operate over an extended temperature range from -40 °C to +85 °C.

Table 1. Device summary

Order codes	Temp. range [°C]	Package	Packaging
LIS3DHTR	-40 to +85	LGA-16	Tape and reel

Contents

1	Block diagram and pin description	8
1.1	Block diagram	8
1.2	Pin description	8
2	Mechanical and electrical specifications	10
2.1	Mechanical characteristics	10
2.2	Temperature sensor characteristics	12
2.3	Electrical characteristics	12
2.4	Communication interface characteristics	13
2.4.1	SPI - serial peripheral interface	13
2.4.2	I ² C - Inter IC control interface	14
2.5	Absolute maximum ratings	15
3	Terminology and functionality	16
3.1	Terminology	16
3.1.1	Sensitivity	16
3.1.2	Zero-g level	16
3.2	Functionality	16
3.2.1	High-resolution, normal mode, low-power mode	16
3.2.2	Self-test	17
3.2.3	6D / 4D orientation detection	18
3.2.4	“Sleep-to-wake” and “Return-to-sleep”	18
3.3	Sensing element	18
3.4	IC interface	18
3.5	Factory calibration	19
3.6	FIFO	19
3.7	Auxiliary ADC and temperature sensor	19
4	Application hints	20
4.1	Soldering information	21
5	Digital main blocks	22
5.1	FIFO	22

5.1.1	Bypass mode	22
5.1.2	FIFO mode	22
5.1.3	Stream mode	23
5.1.4	Stream-to-FIFO mode	23
5.1.5	Retrieving data from FIFO	23
6	Digital interfaces	24
6.1	I ² C serial interface	24
6.1.1	I ² C operation	25
6.2	SPI bus interface	27
6.2.1	SPI read	28
6.2.2	SPI write	29
6.2.3	SPI read in 3-wire mode	30
7	Register mapping	31
8	Registers description	33
8.1	STATUS_REG_AUX (07h)	33
8.2	OUT_ADC1_L (08h), OUT_ADC1_H (09h)	33
8.3	OUT_ADC2_L (0Ah), OUT_ADC2_H (0Bh)	33
8.4	OUT_ADC3_L (0Ch), OUT_ADC3_H (0Dh)	33
8.5	WHO_AM_I (0Fh)	34
8.6	CTRL_REG0 (1Eh)	34
8.7	TEMP_CFG_REG (1Fh)	34
8.8	CTRL_REG1 (20h)	35
8.9	CTRL_REG2 (21h)	36
8.10	CTRL_REG3 (22h)	36
8.11	CTRL_REG4 (23h)	37
8.12	CTRL_REG5 (24h)	38
8.13	CTRL_REG6 (25h)	38
8.14	REFERENCE (26h)	39
8.15	STATUS_REG (27h)	39
8.16	OUT_X_L (28h), OUT_X_H (29h)	40
8.17	OUT_Y_L (2Ah), OUT_Y_H (2Bh)	40
8.18	OUT_Z_L (2Ch), OUT_Z_H (2Dh)	40

8.19	FIFO_CTRL_REG (2Eh)	40
8.20	FIFO_SRC_REG (2Fh)	41
8.21	INT1_CFG (30h)	41
8.22	INT1_SRC (31h)	42
8.23	INT1_THS (32h)	43
8.24	INT1_DURATION (33h)	43
8.25	INT2_CFG (34h)	44
8.26	INT2_SRC (35h)	45
8.27	INT2_THS (36h)	45
8.28	INT2_DURATION (37h)	46
8.29	CLICK_CFG (38h)	46
8.30	CLICK_SRC (39h)	47
8.31	CLICK_THS (3Ah)	47
8.32	TIME_LIMIT (3Bh)	47
8.33	TIME_LATENCY (3Ch)	48
8.34	TIME WINDOW (3Dh)	48
8.35	ACT_THS (3Eh)	48
8.36	ACT_DUR (3Fh)	48
9	Package information	49
9.1	LGA-16 package information	50
9.2	LGA-16 packing information	51
10	Revision history	53

List of tables

Table 1.	Device summary	1
Table 2.	Pin description	9
Table 3.	Internal pull-up values (typ.) for SDO/SA0 pin	9
Table 4.	Mechanical characteristics	10
Table 5.	Temperature sensor characteristics	12
Table 6.	Electrical characteristics	12
Table 7.	SPI slave timing values	13
Table 8.	I ² C slave timing values	14
Table 9.	Absolute maximum ratings	15
Table 10.	Operating mode selection	16
Table 11.	Turn-on time for operating mode transition	17
Table 12.	Current consumption of operating modes	17
Table 13.	Internal pin status	21
Table 14.	Serial interface pin description	24
Table 15.	I ² C terminology	24
Table 16.	SAD+Read/Write patterns	25
Table 17.	Transfer when master is writing one byte to slave	25
Table 18.	Transfer when master is writing multiple bytes to slave	25
Table 19.	Transfer when master is receiving (reading) one byte of data from slave	26
Table 20.	Transfer when master is receiving (reading) multiple bytes of data from slave	26
Table 21.	Register address map	31
Table 22.	STATUS_REG_AUX register	33
Table 23.	STATUS_REG_AUX description	33
Table 24.	WHO_AM_I register	34
Table 25.	CTRL_REG0 register	34
Table 26.	CTRL_REG0 description	34
Table 27.	TEMP_CFG_REG register	34
Table 28.	TEMP_CFG_REG description	34
Table 29.	CTRL_REG1 register	35
Table 30.	CTRL_REG1 description	35
Table 31.	Data rate configuration	35
Table 32.	CTRL_REG2 register	36
Table 33.	CTRL_REG2 description	36
Table 34.	High-pass filter mode configuration	36
Table 35.	CTRL_REG3 register	36
Table 36.	CTRL_REG3 description	36
Table 37.	CTRL_REG4 register	37
Table 38.	CTRL_REG4 description	37
Table 39.	Self-test mode configuration	37
Table 40.	CTRL_REG5 register	38
Table 41.	CTRL_REG5 description	38
Table 42.	CTRL_REG6 register	38
Table 43.	CTRL_REG6 description	38
Table 44.	REFERENCE register	39
Table 45.	REFERENCE register description	39
Table 46.	STATUS register	39
Table 47.	STATUS register description	39
Table 48.	REFERENCE register	40

Table 49.	REFERENCE register description	40
Table 50.	FIFO mode configuration	40
Table 51.	FIFO_SRC_REG register	41
Table 52.	FIFO_SRC_REG description	41
Table 53.	INT1_CFG register	41
Table 54.	INT1_CFG description	41
Table 55.	Interrupt mode	42
Table 56.	INT1_SRC register	42
Table 57.	INT1_SRC description	42
Table 58.	INT1_THS register	43
Table 59.	INT1_THS description	43
Table 60.	INT1_DURATION register	43
Table 61.	INT1_DURATION description	43
Table 62.	INT2_CFG register	44
Table 63.	INT2_CFG description	44
Table 64.	Interrupt mode	44
Table 65.	INT2_SRC register	45
Table 66.	INT2_SRC description	45
Table 67.	INT2_THS register	45
Table 68.	INT2_THS description	45
Table 69.	INT2_DURATION register	46
Table 70.	INT2_DURATION description	46
Table 71.	CLICK_CFG register	46
Table 72.	CLICK_CFG description	46
Table 73.	CLICK_SRC register	47
Table 74.	CLICK_SRC description	47
Table 75.	CLICK_THS register	47
Table 76.	CLICK_SRC description	47
Table 77.	TIME_LIMIT register	47
Table 78.	TIME_LIMIT description	47
Table 79.	TIME_LATENCY register	48
Table 80.	TIME_LATENCY description	48
Table 81.	TIME_WINDOW register	48
Table 82.	TIME_WINDOW description	48
Table 83.	ACT_THS register	48
Table 84.	ACT_THS description	48
Table 85.	ACT_DUR register	48
Table 86.	ACT_DUR description	48
Table 87.	Reel dimensions for carrier tape of LGA-16 package	52
Table 88.	Document revision history	53

List of figures

Figure 1.	Block diagram	8
Figure 2.	Pin connections	8
Figure 3.	SPI slave timing diagram	13
Figure 4.	I ² C slave timing diagram	14
Figure 5.	LIS3DH electrical connections	20
Figure 6.	Read and write protocol	27
Figure 7.	SPI read protocol	28
Figure 8.	Multiple byte SPI read protocol (2-byte example).	28
Figure 9.	SPI write protocol	29
Figure 10.	Multiple byte SPI write protocol (2-byte example).	29
Figure 11.	SPI read protocol in 3-wire mode	30
Figure 12.	LGA-16 package outline and mechanical dimensions	50
Figure 13.	Carrier tape information for LGA-16 package.	51
Figure 14.	LGA-16 package orientation in carrier tape	51
Figure 15.	Reel information for carrier tape of LGA-16 package	52

1 Block diagram and pin description

1.1 Block diagram

Figure 1. Block diagram

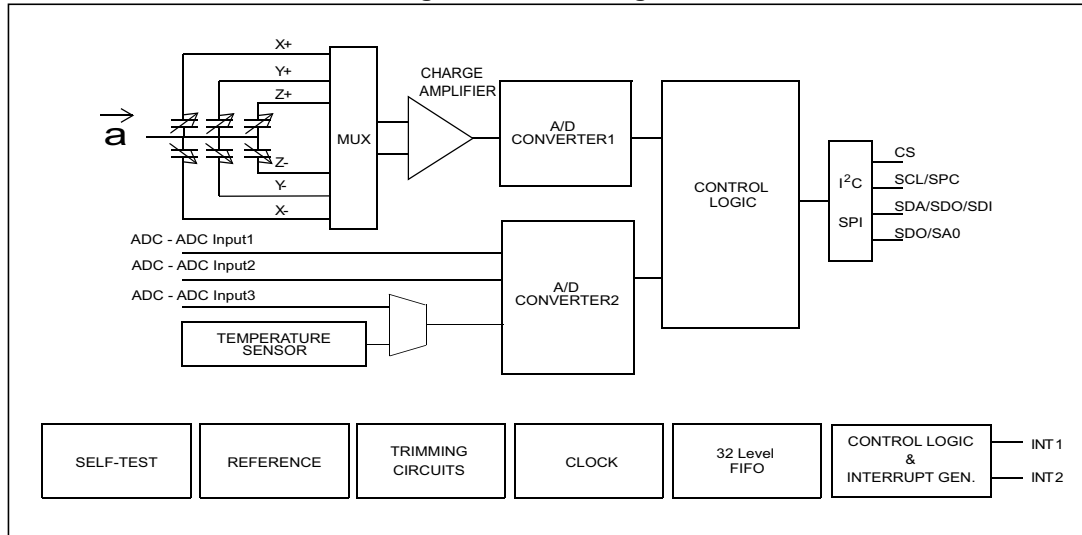

1.2 Pin description

Figure 2. Pin connections

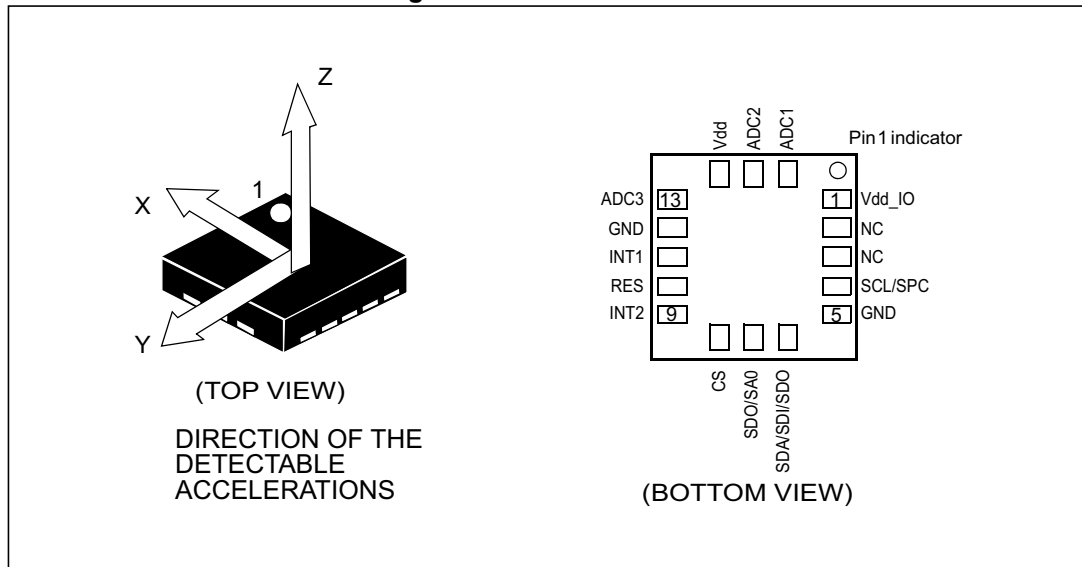

Table 2. Pin description

Pin#	Name	Function
1	Vdd_IO	Power supply for I/O pins
2	NC	Not connected
3	NC	Not connected
4	SCL SPC	I ² C serial clock (SCL) SPI serial port clock (SPC)
5	GND	0 V supply
6	SDA SDI SDO	I ² C serial data (SDA) SPI serial data input (SDI) 3-wire interface serial data output (SDO)
7 ⁽¹⁾	SDO SA0	SPI serial data output (SDO) I ² C less significant bit of the device address (SA0)
8	CS	SPI enable I ² C/SPI mode selection: 1: SPI idle mode / I ² C communication enabled 0: SPI communication mode / I ² C disabled
9	INT2	Inertial interrupt 2
10	RES	Connect to GND
11	INT1	Inertial interrupt 1
12	GND	0 V supply
13	ADC3	Analog-to-digital converter input 3
14	Vdd	Power supply
15	ADC2	Analog-to-digital converter input 2
16	ADC1	Analog-to-digital converter input 1

1. SDO/SA0 pin is internally pulled up. Refer to [Table 3](#) for the internal pull-up values (typ.).

Table 3. Internal pull-up values (typ.) for SDO/SA0 pin

Vdd_IO	Resistor value for SDO/SA0 pin
	Typ. (k Ω)
1.7 V	54.4
1.8 V	49.2
2.5 V	30.4
3.6 V	20.4

2 Mechanical and electrical specifications

2.1 Mechanical characteristics

V_{dd} = 2.5 V, T = 25 °C unless otherwise noted ^(a)

Table 4. Mechanical characteristics

Symbol	Parameter	Test conditions	Min.	Typ. ⁽¹⁾	Max.	Unit
FS	Measurement range ⁽²⁾	FS bit set to 00		±2.0		
		FS bit set to 01		±4.0		
		FS bit set to 10		±8.0		
		FS bit set to 11		±16.0		g
So	Sensitivity	FS bit set to 00; High-resolution mode		1		mg/digit
		FS bit set to 00; Normal mode		4		
		FS bit set to 00; Low-power mode		16		
		FS bit set to 01; High-resolution mode		2		mg/digit
		FS bit set to 01; Normal mode		8		
		FS bit set to 01; Low-power mode		32		
		FS bit set to 10; High-resolution mode		4		mg/digit
		FS bit set to 10; Normal mode		16		
		FS bit set to 10; Low-power mode		64		
		FS bit set to 11; High-resolution mode		12		mg/digit
		FS bit set to 11; Normal mode		48		
		FS bit set to 11; Low-power mode		192		
TCS _o	Sensitivity change vs temperature	FS bit set to 00		0.01		%/°C
TyOff	Typical zero-g level offset accuracy ^{(3),(4)}	FS bit set to 00		±40		mg

a. The product is factory calibrated at 2.5 V. The operational power supply range is from 1.71 V to 3.6 V.

Table 4. Mechanical characteristics

Symbol	Parameter	Test conditions	Min.	Typ. ⁽¹⁾	Max.	Unit
TCOff	Zero-g level change vs temperature	Max delta from 25 °C		±0.5		mg/°C
An	Acceleration noise density	FS bit set to 00, High-Resolution mode (Table 10), ODR > 1300 Hz		220		µg/√Hz
Vst	Self-test output change ⁽⁵⁾⁽⁶⁾⁽⁷⁾	FS bit set to 00 X-axis; Normal mode	17		360	LSb
		FS bit set to 00 Y-axis; Normal mode	17		360	LSb
		FS bit set to 00 Z-axis; Normal mode	17		360	LSb
Top	Operating temperature range		-40		+85	°C

1. Typical specifications are not guaranteed.
2. Verified by wafer level test and measurement of initial offset and sensitivity.
3. Typical zero-g level offset value after MSL3 preconditioning.
4. Offset can be eliminated by enabling the built-in high-pass filter.
5. The sign of "Self-test output change" is defined by the ST bits in [CTRL_REG4 \(23h\)](#), for all axes.
6. "Self-test output change" is defined as the absolute value of:
 $OUTPUT[LSb]_{(Self\ test\ enabled)} - OUTPUT[LSb]_{(Self\ test\ disabled)}$. 1LSb = 4 mg at 10-bit representation, ±2 g full scale.
7. After enabling the self-test, correct data is obtained after two samples (low-power mode / normal mode) or after eight samples (high-resolution mode).

2.2 Temperature sensor characteristics

Vdd = 2.5 V, T = 25 °C unless otherwise noted ^(b)

Table 5. Temperature sensor characteristics

Symbol	Parameter	Test condition	Min.	Typ. ⁽¹⁾	Max.	Unit
TSDr	Temperature sensor output change vs temperature			1		digit/°C ⁽²⁾
TODR	Temperature refresh rate			ODR		Hz
Top	Operating temperature range		-40		+85	°C

1. Typical specifications are not guaranteed.
2. 8-bit resolution.

2.3 Electrical characteristics

Vdd = 2.5 V, T = 25 °C unless otherwise noted ^(c)

Table 6. Electrical characteristics

Symbol	Parameter	Test conditions	Min.	Typ. ⁽¹⁾	Max.	Unit
Vdd	Supply voltage		1.71	2.5	3.6	V
Vdd_IO	I/O pins supply voltage ⁽²⁾		1.71		Vdd+0.1	V
Idd	Current consumption in normal mode	50 Hz ODR		11		µA
Idd	Current consumption in normal mode	1 Hz ODR		2		µA
IddLP	Current consumption in low-power mode	50 Hz ODR		6		µA
IddPdn	Current consumption in power-down mode			0.5		µA
VIH	Digital high-level input voltage		0.8*Vdd_IO			V
VIL	Digital low-level input voltage				0.2*Vdd_IO	V
VOH	High-level output voltage		0.9*Vdd_IO			V
VOL	Low-level output voltage				0.1*Vdd_IO	V
BW	System bandwidth ⁽³⁾			ODR/2		Hz
Top	Operating temperature range		-40		+85	°C

1. Typical specification are not guaranteed.
2. It is possible to remove Vdd maintaining Vdd_IO without blocking the communication busses, in this condition the measurement chain is powered off.
3. Refer to [Table 25](#) for the ODR value and configuration.

b. The product is factory calibrated at 2.5 V. Temperature sensor operation is guaranteed in the range 2 V - 3.6 V.
 c. The product is factory calibrated at 2.5 V. The operational power supply range is from 1.71 V to 3.6 V.

2.4 Communication interface characteristics

2.4.1 SPI - serial peripheral interface

Subject to general operating conditions for Vdd and Top.

Table 7. SPI slave timing values

Symbol	Parameter	Value ⁽¹⁾		Unit
		Min	Max	
$t_{c(SPC)}$	SPI clock cycle	100		ns
$f_{c(SPC)}$	SPI clock frequency		10	MHz
$t_{su(CS)}$	CS setup time	5		ns
$t_{h(CS)}$	CS hold time	20		
$t_{su(SI)}$	SDI input setup time	5		
$t_{h(SI)}$	SDI input hold time	15		
$t_{v(SO)}$	SDO valid output time		50	
$t_{h(SO)}$	SDO output hold time	5		
$t_{dis(SO)}$	SDO output disable time		50	

1. Values are guaranteed at 10 MHz clock frequency for SPI with both 4 and 3 wires, based on characterization results, not tested in production.

Figure 3. SPI slave timing diagram

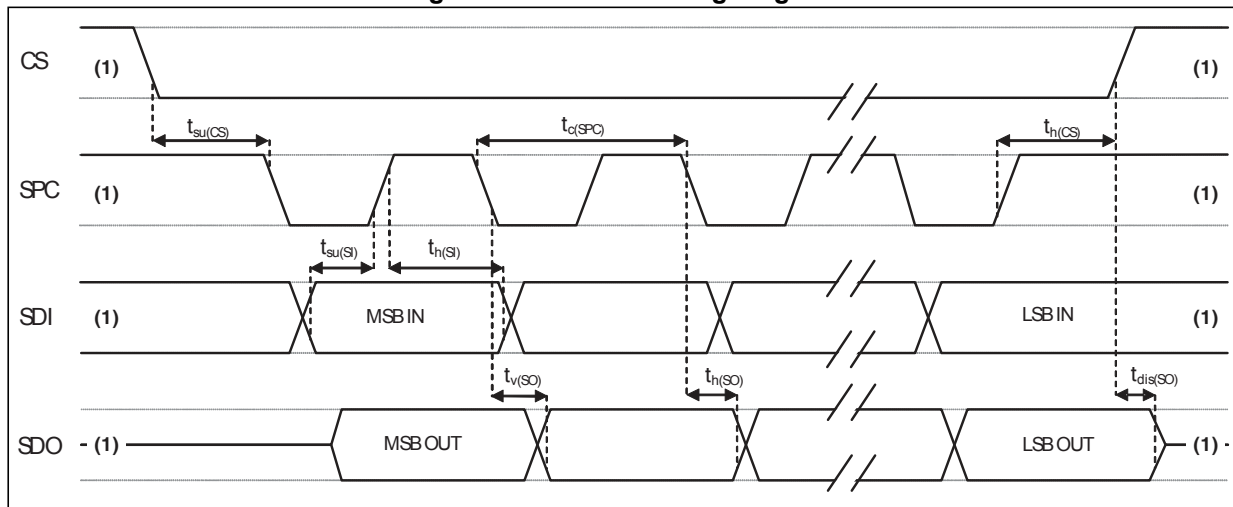

1. When no communication is ongoing, data on SDO is driven by internal pull-up resistors.

Note: Measurement points are done at $0.2 \cdot V_{dd_IO}$ and $0.8 \cdot V_{dd_IO}$, for both input and output ports.

2.4.2 I²C - Inter IC control interface

Subject to general operating conditions for Vdd and top.

Table 8. I²C slave timing values

Symbol	Parameter	I ² C standard		I ² C fast mode ⁽¹⁾		Unit
		Min	Max	Min	Max	
f _(SCL)	SCL clock frequency	0	100	0	400	kHz
t _{w(SCLL)}	SCL clock low time	4.7		1.3		μs
t _{w(SCLH)}	SCL clock high time	4.0		0.6		
t _{su(SDA)}	SDA setup time	250		100		ns
t _{h(SDA)}	SDA data hold time	0	3.45	0	0.9	μs
t _{h(ST)}	START condition hold time	4		0.6		μs
t _{su(SR)}	Repeated START condition setup time	4.7		0.6		
t _{su(SP)}	STOP condition setup time	4		0.6		
t _{w(SP:SR)}	Bus free time between STOP and START condition	4.7		1.3		

1. Data based on standard I²C protocol requirement, not tested in production.

Figure 4. I²C slave timing diagram

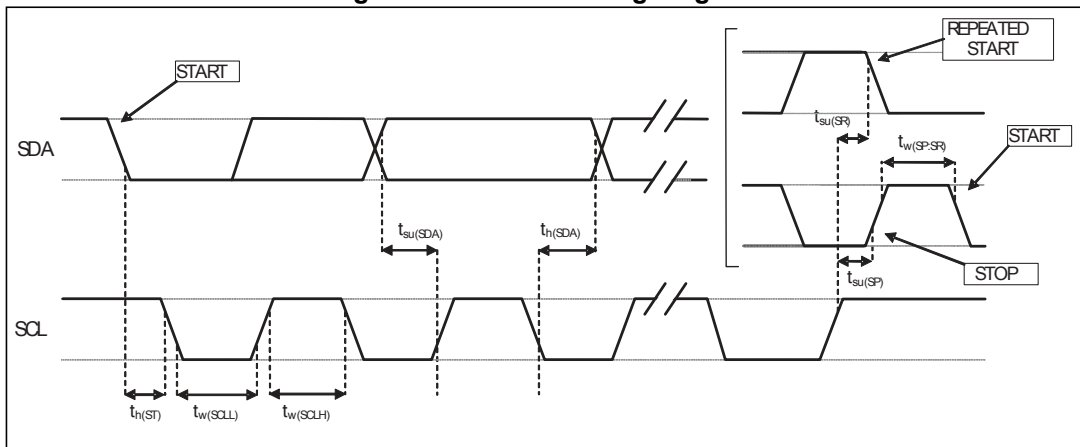

Note: Measurement points are done at 0.2·Vdd_{IO} and 0.8·Vdd_{IO}, for both ports.

2.5 Absolute maximum ratings

Stresses above those listed as “absolute maximum ratings” may cause permanent damage to the device. This is a stress rating only and functional operation of the device under these conditions is not implied. Exposure to maximum rating conditions for extended periods may affect device reliability.

Table 9. Absolute maximum ratings

Symbol	Ratings	Maximum value	Unit
V _{dd}	Supply voltage	-0.3 to 4.8	V
V _{dd_IO}	I/O pins Supply voltage	-0.3 to 4.8	V
V _{in}	Input voltage on any control pin (CS, SCL/SPC, SDA/SDI/SDO, SDO/SA0)	-0.3 to V _{dd_IO} +0.3	V
A _{POW}	Acceleration (any axis, powered, V _{dd} = 2.5 V)	3000 g for 0.5 ms	
		10000 g for 0.2 ms	
A _{UNP}	Acceleration (any axis, unpowered)	3000 g for 0.5 ms	
		10000 g for 0.2 ms	
T _{OP}	Operating temperature range	-40 to +85	°C
T _{STG}	Storage temperature range	-40 to +125	°C
ESD	Electrostatic discharge protection	2 (HBM)	kV

Note: Supply voltage on any pin should never exceed 4.8 V



This device is sensitive to mechanical shock, improper handling can cause permanent damage to the part.



This device is sensitive to electrostatic discharge (ESD), improper handling can cause permanent damage to the part.

3 Terminology and functionality

3.1 Terminology

3.1.1 Sensitivity

Sensitivity describes the gain of the sensor and can be determined, for example, by applying 1 *g* acceleration to it. As the sensor can measure DC accelerations this can be done easily by pointing the axis of interest towards the center of the Earth, noting the output value, rotating the sensor by 180 degrees (pointing to the sky) and noting the output value again. By doing so, ± 1 *g* acceleration is applied to the sensor. Subtracting the larger output value from the smaller one, and dividing the result by 2, leads to the actual sensitivity of the sensor. This value changes very little over temperature and also time. The sensitivity tolerance describes the range of sensitivities of a large population of sensors.

3.1.2 Zero-*g* level

The zero-*g* level offset (TyOff) describes the deviation of an actual output signal from the ideal output signal if no acceleration is present. A sensor in a steady state on a horizontal surface measures 0 *g* for the X-axis and 0 *g* for the Y-axis whereas the Z-axis measures 1 *g*. The output is ideally in the middle of the dynamic range of the sensor (content of OUT registers 00h, data expressed as 2's complement number). A deviation from ideal value in this case is called Zero-*g* offset. Offset is to some extent a result of stress to MEMS sensor and therefore the offset can slightly change after mounting the sensor onto a printed circuit board or exposing it to extensive mechanical stress. Offset changes little over temperature, see [Table 4](#) "Zero-*g* level change vs. temperature" (TCOff). The zero-*g* level tolerance (TyOff) describes the standard deviation of the range of zero-*g* levels of a population of sensors.

3.2 Functionality

3.2.1 High-resolution, normal mode, low-power mode

LIS3DH provides three different operating modes: *high-resolution mode*, *normal mode* and *low-power mode*.

The table below summarizes how to select the operating mode.

Table 10. Operating mode selection

Operating mode	CTRL_REG1[3] (LPen bit)	CTRL_REG4[3] (HR bit)	BW [Hz]	Turn-on time [ms]	So @ $\pm 2g$ [mg/digit]
Low-power mode (8-bit data output)	1	0	ODR/2	1	16
Normal mode (10-bit data output)	0	0	ODR/2	1.6	4
High-resolution mode (12-bit data output)	0	1	ODR/9	7/ODR	1
Not allowed	1	1	--	--	--

The turn-on time to transition to another operating mode is given in [Table 11](#).

Table 11. Turn-on time for operating mode transition

Operating mode change	Turn-on time [ms]
12-bit mode to 8-bit mode	1/ODR
12-bit mode to 10-bit mode	1/ODR
10-bit mode to 8-bit mode	1/ODR
10-bit mode to 12-bit mode	7/ODR
8-bit mode to 10-bit mode	1/ODR
8-bit mode to 12-bit mode	7/ODR

Table 12. Current consumption of operating modes

Operating mode [Hz]	Low-power mode (8-bit data output) [μ A]	Normal mode (10-bit data output) [μ A]	High resolution (12-bit data output) [μ A]
1	2	2	2
10	3	4	4
25	4	6	6
50	6	11	11
100	10	20	20
200	18	38	38
400	36	73	73
1344	--	185	185
1620	100	--	--
5376	185	--	--

3.2.2 Self-test

The self-test allows the user to check the sensor functionality without moving it. The self-test function is off when the self-test bit (ST) is programmed to '0'. When the self-test bit is programmed to '1', an actuation force is applied to the sensor, simulating a definite input acceleration. In this case the sensor outputs exhibit a change in their DC levels which are related to the selected full scale through the device sensitivity. When the self-test is activated, the device output level is given by the algebraic sum of the signals produced by the acceleration acting on the sensor and by the electrostatic test-force. If the output signals change within the amplitude specified inside [Table 4](#), then the sensor is working properly and the parameters of the interface chip are within the defined specifications.

3.2.3 6D / 4D orientation detection

The LIS3DH provides the capability to detect the orientation of the device in space, enabling easy implementation of energy-saving procedures and automatic image rotation for mobile devices.

The 4D detection is a subset of the 6D function especially defined to be implemented in mobile devices for portrait and landscape computation. In 4D configuration, the Z-axis position detection is disabled.

3.2.4 “Sleep-to-wake” and “Return-to-sleep”

The LIS3DH can be programmed to automatically switch to low-power mode upon recognition of a determined event.

Once the event condition is over, the device returns back to the preset normal or high-resolution mode.

To enable this function the desired threshold value must be stored inside the *ACT_THS (3Eh)* register while the duration value is written inside the *ACT_DUR (3Fh)* register.

When the acceleration falls below the threshold value, the device automatically switches to low-power mode (10 Hz ODR).

During this condition, the ODR[3:0] bits and the LPen bit inside *CTRL_REG1 (20h)* and the HR bit in *CTRL_REG4 (23h)* are not considered.

As soon as the acceleration rises above threshold, the module restores the operating mode and ODRs as determined by the *CTRL_REG1 (20h)* and *CTRL_REG4 (23h)* settings.

3.3 Sensing element

A proprietary process is used to create a surface micro-machined accelerometer. The technology allows carrying out suspended silicon structures which are attached to the substrate in a few points called anchors and are free to move in the direction of the sensed acceleration. To be compatible with the traditional packaging techniques a cap is placed on top of the sensing element to avoid blocking the moving parts during the moulding phase of the plastic encapsulation.

When an acceleration is applied to the sensor the proof mass displaces from its nominal position, causing an imbalance in the capacitive half-bridge. This imbalance is measured using charge integration in response to a voltage pulse applied to the capacitor.

At steady state the nominal value of the capacitors are few pF and when an acceleration is applied the maximum variation of the capacitive load is in the fF range.

3.4 IC interface

The complete measurement chain is composed by a low-noise capacitive amplifier which converts the capacitive unbalancing of the MEMS sensor into an analog voltage that is finally available to the user by an analog-to-digital converter.

The acceleration data may be accessed through an I²C/SPI interface thus making the device particularly suitable for direct interfacing with a microcontroller.

The LIS3DH features a Data-Ready signal (DRDY) which indicates when a new set of measured acceleration data is available, thus simplifying data synchronization in the digital system that uses the device.

The LIS3DH may also be configured to generate an inertial wake-up and free-fall interrupt signal accordingly to a programmed acceleration event along the enabled axes. Both free-fall and wake-up can be available simultaneously on two different pins.

3.5 Factory calibration

The IC interface is factory calibrated for sensitivity (So) and Zero-g level (TyOff).

The trim values are stored inside the device in non-volatile memory. Any time the device is turned on, these values are downloaded into the registers to be used during active operation. This allows using the device without further calibration.

3.6 FIFO

The LIS3DH contains a 10-bit, 32-level FIFO. Buffered output allows 4 operation modes: FIFO, Stream, Stream-to-FIFO and FIFO bypass. When FIFO bypass mode is activated, FIFO is not operating and remains empty. In FIFO mode, measurement data from acceleration detection on the x, y, and z axes are stored in the FIFO buffer.

3.7 Auxiliary ADC and temperature sensor

The LIS3DH contains an auxiliary ADC with 3 separate dedicated inputs: pins ADC1, ADC2, ADC3.

The user can retrieve the converted data from registers [OUT_ADC1_L \(08h\)](#), [OUT_ADC1_H \(09h\)](#), [OUT_ADC2_L \(0Ah\)](#), [OUT_ADC2_H \(0Bh\)](#) and [OUT_ADC3_L \(0Ch\)](#), [OUT_ADC3_H \(0Dh\)](#).

In order to use the auxiliary ADC, the user must set the BDU bit (bit 7) to 1 in [CTRL_REG4 \(23h\)](#) and the ADC_EN bit (bit 7) to 1 in [TEMP_CFG_REG \(1Fh\)](#). The ADC sampling frequency is the same as that of the ODR in [CTRL_REG1 \(20h\)](#).

The input range is 1200 mV \pm 400 mV and the data output is expressed in 2's complement left-aligned.

The ADC resolution is 10 bits if the LPen (bit 3) in [CTRL_REG1 \(20h\)](#) is cleared (high-resolution / normal mode), otherwise, in low-power mode, the ADC resolution is 8-bit.

Channel 3 of the ADC can be connected to the temperature sensor by setting the TEMP_EN bit (bit 6) to 1 in [TEMP_CFG_REG \(1Fh\)](#). Refer to [Table 5: Temperature sensor characteristics](#) for the conversion factor.

4 Application hints

Figure 5. LIS3DH electrical connections

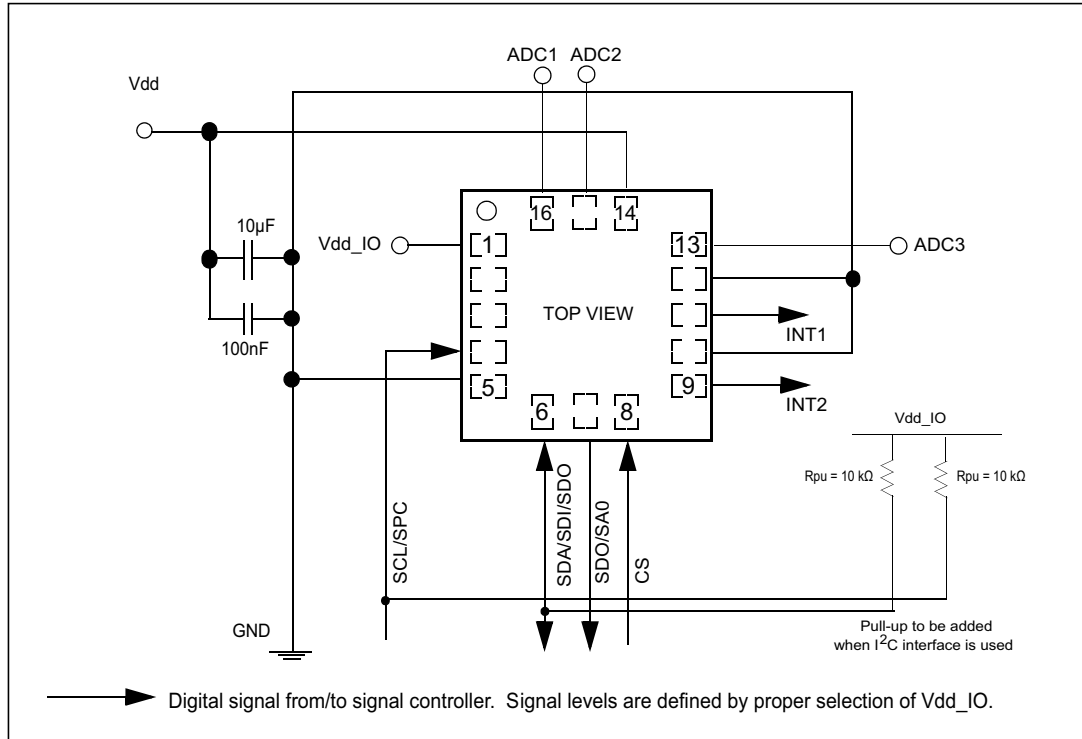

The device core is supplied through the Vdd line while the I/O pads are supplied through the Vdd_IO line. Power supply decoupling capacitors (100 nF ceramic, 10 µF aluminum) should be placed as near as possible to pin 14 of the device (common design practice).

All the voltage and ground supplies must be present at the same time to have proper behavior of the IC (refer to [Figure 5](#)). It is possible to remove Vdd maintaining Vdd_IO without blocking the communication bus, in this condition the measurement chain is powered off.

The functionality of the device and the measured acceleration data is selectable and accessible through the I²C or SPI interfaces. When using the I²C, CS must be tied high.

ADC1, ADC2 & ADC3 if not used can be left floating or connected to Vdd or GND.

The functions, the threshold and the timing of the two interrupt pins (INT1 and INT2) can be completely programmed by the user through the I²C/SPI interface.

Table 13. Internal pin status

Pin#	Name	Function	Pin status
1	Vdd_IO	Power supply for I/O pins	
2	NC	Not connected	
3	NC	Not connected	
4	SCL SPC	I ² C serial clock (SCL) SPI serial port clock (SPC)	Default: input high impedance
5	GND	0 V supply	
6	SDA SDI SDO	I ² C serial data (SDA) SPI serial data input (SDI) 3-wire interface serial data output (SDO)	Default: (SDA) input high impedance
7	SDO SA0	SPI serial data output (SDO) I ² C less significant bit of the device address (SA0)	Default: input with internal pull-up ⁽¹⁾
8	CS	SPI enable I ² C/SPI mode selection: 1: SPI idle mode / I ² C communication enabled 0: SPI communication mode / I ² C disabled	Default: input high impedance
9	INT2	Inertial interrupt 2	Default: push-pull output forced to GND
10	RES	Connect to GND	
11	INT1	Inertial interrupt 1	Default: push-pull output forced to GND
12	GND	0 V supply	
13	ADC3	Analog-to-digital converter input 3	Default: input high impedance
14	Vdd	Power supply	
15	ADC2	Analog-to-digital converter input 2	Default: input high impedance
16	ADC1	Analog-to-digital converter input 1	Default: input high impedance

1. In order to disable the internal pull-up on the SDO/SA0 pin, write 90h in [CTRL_REG0 \(1Eh\)](#).

4.1 Soldering information

The LGA package is compliant with the ECOPACK[®], RoHS and “Green” standard. It is qualified for soldering heat resistance according to JEDEC J-STD-020.

Leave “Pin 1 Indicator” unconnected during soldering.

Land pattern and soldering recommendations are available at www.st.com.

5 Digital main blocks

5.1 FIFO

The LIS3DH embeds a 32-level FIFO for each of the three output channels, X, Y and Z.

This allows consistent power saving for the system, since the host processor does not need to continuously poll data from the sensor, but it can wake up only when needed and burst the significant data out from the FIFO.

In order to enable the FIFO buffer, the FIFO_EN bit in [CTRL_REG5 \(24h\)](#) must be set to '1'.

This buffer can work according to the following different modes: Bypass mode, FIFO mode, Stream mode and Stream-to-FIFO mode. Each mode is selected by the FM [1:0] bits in [FIFO_CTRL_REG \(2Eh\)](#). Programmable FIFO watermark level, FIFO empty or FIFO overrun events can be enabled to generate dedicated interrupts on the INT1 pin (configuration through [CTRL_REG3 \(22h\)](#)).

In the [FIFO_SRC_REG \(2Fh\)](#) register the EMPTY bit is equal to '1' when all FIFO samples are ready and FIFO is empty.

In the [FIFO_SRC_REG \(2Fh\)](#) register the WTM bit goes to '1' if new data is written in the buffer and [FIFO_SRC_REG \(2Fh\)](#) (FSS [4:0]) is greater than or equal to [FIFO_CTRL_REG \(2Eh\)](#) (FTH [4:0]). [FIFO_SRC_REG \(2Fh\)](#) (WTM) goes to '0' if reading an X, Y, Z data slot from FIFO and [FIFO_SRC_REG \(2Fh\)](#) (FSS [4:0]) is less than or equal to [FIFO_CTRL_REG \(2Eh\)](#) (FTH [4:0]).

In the [FIFO_SRC_REG \(2Fh\)](#) register the OVRN_FIFO bit is equal to '1' if the FIFO slot is overwritten.

5.1.1 Bypass mode

In Bypass mode the FIFO is not operational and for this reason it remains empty. For each channel only the first address is used. The remaining FIFO levels are empty.

Bypass mode must be used in order to reset the FIFO buffer when a different mode is operating (i.e. FIFO mode).

5.1.2 FIFO mode

In FIFO mode, the buffer continues filling data from the X, Y and Z accelerometer channels until it is full (a set of 32 samples stored). When the FIFO is full, it stops collecting data from the input channels and the FIFO content remains unchanged.

An overrun interrupt can be enabled, I1_OVERRUN = '1' in the [CTRL_REG3 \(22h\)](#) register, in order to be raised when the FIFO stops collecting data. When the overrun interrupt occurs, the first data has been overwritten and the FIFO stops collecting data from the input channels.

After the last read it is necessary to exit Bypass mode in order to reset the FIFO content. After this reset command, it is possible to restart FIFO mode just by selecting the FIFO mode configuration (FM[1:0] bits) in register [FIFO_CTRL_REG \(2Eh\)](#).

5.1.3 Stream mode

In Stream mode the FIFO continues filling data from the X, Y, and Z accelerometer channels until the buffer is full (a set of 32 samples stored) at which point the FIFO buffer index restarts from the beginning and older data is replaced by the current data. The oldest values continue to be overwritten until a read operation frees the FIFO slots.

An overrun interrupt can be enabled, `I1_OVERRUN = '1'` in the [CTRL_REG3 \(22h\)](#) register, in order to read the entire contents of the FIFO at once. If, in the application, it is mandatory not to lose data and it is not possible to read at least one sample for each axis within one ODR period, a watermark interrupt can be enabled in order to read partially the FIFO and leave memory slots free for incoming data.

Setting the FTH [4:0] bit in the [FIFO_CTRL_REG \(2Eh\)](#) register to an N value, the number of X, Y and Z data samples that should be read at the rise of the watermark interrupt is up to (N+1).

5.1.4 Stream-to-FIFO mode

In Stream-to-FIFO mode, data from the X, Y and Z accelerometer channels are collected in a combination of Stream mode and FIFO mode. The FIFO buffer starts operating in Stream mode and switches to FIFO mode when the selected interrupt occurs.

The FIFO operating mode changes according to the INT1 pin value if the TR bit is set to '0' in the [FIFO_CTRL_REG \(2Eh\)](#) register or the INT2 pin value if the TR bit is set to '1' in the [FIFO_CTRL_REG \(2Eh\)](#) register.

When the interrupt pin is selected and the interrupt event is configured on the corresponding pin, the FIFO operates in Stream mode if the pin value is equal to '0' and it operates in FIFO mode if the pin value is equal to '1'. Switching modes is dynamically performed according to the pin value.

Stream-to-FIFO can be used in order to analyze the sampling history that generates an interrupt. The standard operation is to read the contents of FIFO when the FIFO mode is triggered and the FIFO buffer is full and stopped.

5.1.5 Retrieving data from FIFO

FIFO data is read from [OUT_X_L \(28h\)](#), [OUT_X_H \(29h\)](#), [OUT_Y_L \(2Ah\)](#), [OUT_Y_H \(2Bh\)](#) and [OUT_Z_L \(2Ch\)](#), [OUT_Z_H \(2Dh\)](#). When the FIFO is in Stream, Stream-to-FIFO or FIFO mode, a read operation from the [OUT_X_L \(28h\)](#), [OUT_X_H \(29h\)](#), [OUT_Y_L \(2Ah\)](#), [OUT_Y_H \(2Bh\)](#) or [OUT_Z_L \(2Ch\)](#), [OUT_Z_H \(2Dh\)](#) registers provides the data stored in the FIFO. Each time data is read from the FIFO, the oldest X, Y and Z data are placed in the [OUT_X_L \(28h\)](#), [OUT_X_H \(29h\)](#), [OUT_Y_L \(2Ah\)](#), [OUT_Y_H \(2Bh\)](#) and [OUT_Z_L \(2Ch\)](#), [OUT_Z_H \(2Dh\)](#) registers and both single read and read burst operations can be used.

The address to be read is automatically updated by the device and it rolls back to 0x28 when register 0x2D is reached. In order to read all FIFO levels in a multiple byte read, 192 bytes (6 output registers of 32 levels) have to be read.

6 Digital interfaces

The registers embedded inside the LIS3DH may be accessed through both the I²C and SPI serial interfaces. The latter may be SW configured to operate either in 3-wire or 4-wire interface mode.

The serial interfaces are mapped onto the same pads. To select/exploit the I²C interface, the CS line must be tied high (i.e. connected to Vdd_IO).

Table 14. Serial interface pin description

Pin name	Pin description
CS	SPI enable I ² C/SPI mode selection: 1: SPI idle mode / I ² C communication enabled 0: SPI communication mode / I ² C disabled
SCL SPC	I ² C serial clock (SCL) SPI serial port clock (SPC)
SDA SDI SDO	I ² C serial data (SDA) SPI serial data input (SDI) 3-wire interface serial data output (SDO)
SA0 SDO	I ² C less significant bit of the device address (SA0) SPI serial data output (SDO)

6.1 I²C serial interface

The LIS3DH I²C is a bus slave. The I²C is employed to write data into registers whose content can also be read back.

The relevant I²C terminology is given in the table below.

Table 15. I²C terminology

Term	Description
Transmitter	The device which sends data to the bus
Receiver	The device which receives data from the bus
Master	The device which initiates a transfer, generates clock signals and terminates a transfer
Slave	The device addressed by the master

There are two signals associated with the I²C bus: the serial clock line (SCL) and the Serial DATA line (SDA). The latter is a bidirectional line used for sending and receiving the data to/from the interface. Both the lines must be connected to Vdd_IO through external pull-up resistor. When the bus is free both the lines are high.

The I²C interface is compliant with fast mode (400 kHz) I²C standards as well as with normal mode.

6.1.1 I²C operation

The transaction on the bus is started through a START (ST) signal. A START condition is defined as a HIGH-to-LOW transition on the data line while the SCL line is held HIGH. After this has been transmitted by the Master, the bus is considered busy. The next byte of data transmitted after the start condition contains the address of the slave in the first 7 bits and the eighth bit tells whether the Master is receiving data from the slave or transmitting data to the slave. When an address is sent, each device in the system compares the first seven bits after a start condition with its address. If they match, the device considers itself addressed by the Master.

The Slave Address (SAD) associated to the LIS3DH is 001100xb. The **SDO/SA0** pad can be used to modify the less significant bit of the device address. If the SA0 pad is connected to the voltage supply, LSb is '1' (address 0011001b) else if SA0 pad is connected to ground, the LSb value is '0' (address 0011000b). This solution permits to connect and address two different accelerometers to the same I²C lines.

Data transfer with acknowledge is mandatory. The transmitter must release the SDA line during the acknowledge pulse. The receiver must then pull the data line LOW so that it remains stable low during the HIGH period of the acknowledge clock pulse. A receiver which has been addressed is obliged to generate an acknowledge after each byte of data received.

The I²C embedded inside the LIS3DH behaves like a slave device and the following protocol must be adhered to. After the start condition (ST) a slave address is sent, once a slave acknowledge (SAK) has been returned, an 8-bit sub-address (SUB) is transmitted: the 7 LSb represent the actual register address while the MSB enables address auto increment. If the MSb of the SUB field is '1', the SUB (register address) is automatically increased to allow multiple data read/writes.

The slave address is completed with a Read/Write bit. If the bit was '1' (Read), a repeated START (SR) condition must be issued after the two sub-address bytes; if the bit is '0' (Write) the Master transmit to the slave with direction unchanged. *Table 16* explains how the SAD+Read/Write bit pattern is composed, listing all the possible configurations.

Table 16. SAD+Read/Write patterns

Command	SAD[6:1]	SAD[0] = SA0	R/W	SAD+R/W
Read	001100	0	1	00110001 (31h)
Write	001100	0	0	00110000 (30h)
Read	001100	1	1	00110011 (33h)
Write	001100	1	0	00110010 (32h)

Table 17. Transfer when master is writing one byte to slave

Master	ST	SAD + W		SUB		DATA		SP
Slave			SAK		SAK		SAK	

Table 18. Transfer when master is writing multiple bytes to slave

Master	ST	SAD + W		SUB		DATA		DATA		SP
Slave			SAK		SAK		SAK		SAK	

Table 19. Transfer when master is receiving (reading) one byte of data from slave

Master	ST	SAD + W		SUB		SR	SAD + R			NMAK	SP
Slave			SAK		SAK			SAK	DATA		

Table 20. Transfer when master is receiving (reading) multiple bytes of data from slave

Master	ST	SAD+W		SUB		SR	SAD+R			MAK		MAK		NMAK	SP
Slave			SAK		SAK			SAK	DATA		DATA		DATA		

Data are transmitted in byte format (DATA). Each data transfer contains 8 bits. The number of bytes transferred per transfer is unlimited. Data is transferred with the Most Significant bit (MSb) first. If a receiver can't receive another complete byte of data until it has performed some other function, it can hold the clock line, SCL LOW to force the transmitter into a wait state. Data transfer only continues when the receiver is ready for another byte and releases the data line. If a slave receiver doesn't acknowledge the slave address (i.e. it is not able to receive because it is performing some real-time function) the data line must be left HIGH by the slave. The Master can then abort the transfer. A LOW-to-HIGH transition on the SDA line while the SCL line is HIGH is defined as a STOP condition. Each data transfer must be terminated by the generation of a STOP (SP) condition.

In order to read multiple bytes, it is necessary to assert the most significant bit of the sub-address field. In other words, SUB(7) must be equal to 1 while SUB(6-0) represents the address of first register to be read.

In the presented communication format MAK is Master acknowledge and NMAK is No Master Acknowledge.

6.2 SPI bus interface

The LIS3DH SPI is a bus slave. The SPI allows writing to and reading from the registers of the device.

The serial interface interacts with the application using 4 wires: **CS**, **SPC**, **SDI** and **SDO**.

Figure 6. Read and write protocol

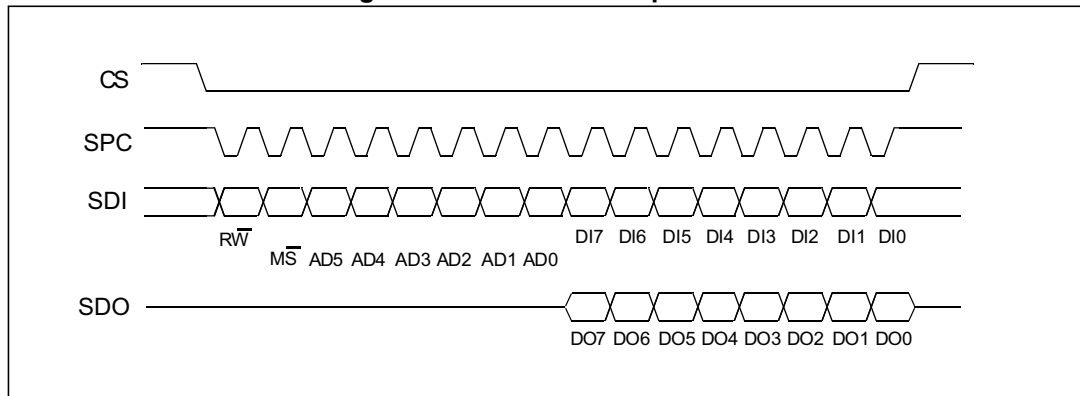

CS is the serial port enable and it is controlled by the SPI master. It goes low at the start of the transmission and goes back high at the end. **SPC** is the serial port clock and it is controlled by the SPI master. It is stopped high when **CS** is high (no transmission). **SDI** and **SDO** are respectively the serial port data input and output. Those lines are driven at the falling edge of **SPC** and should be captured at the rising edge of **SPC**.

Both the read register and write register commands are completed in 16 clock pulses or in multiples of 8 in case of multiple read/write bytes. Bit duration is the time between two falling edges of **SPC**. The first bit (bit 0) starts at the first falling edge of **SPC** after the falling edge of **CS** while the last bit (bit 15, bit 23, ...) starts at the last falling edge of **SPC** just before the rising edge of **CS**.

bit 0: \overline{RW} bit. When 0, the data DI(7:0) is written into the device. When 1, the data DO(7:0) from the device is read. In latter case, the chip drives **SDO** at the start of bit 8.

bit 1: \overline{MS} bit. When 0, the address remains unchanged in multiple read/write commands. When 1, the address is auto incremented in multiple read/write commands.

bit 2-7: address AD(5:0). This is the address field of the indexed register.

bit 8-15: data DI(7:0) (write mode). This is the data that is written into the device (MSb first).

bit 8-15: data DO(7:0) (read mode). This is the data that is read from the device (MSb first).

In multiple read/write commands further blocks of 8 clock periods are added. When the \overline{MS} bit is '0', the address used to read/write data remains the same for every block. When the \overline{MS} bit is '1', the address used to read/write data is increased at every block.

The function and the behavior of **SDI** and **SDO** remain unchanged.

6.2.1 SPI read

Figure 7. SPI read protocol

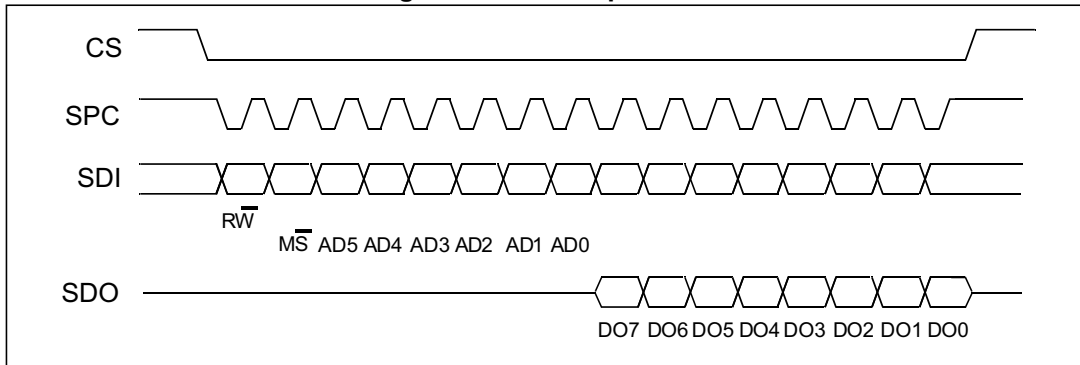

The SPI read command is performed with 16 clock pulses. A multiple byte read command is performed by adding blocks of 8 clock pulses to the previous one.

bit 0: READ bit. The value is 1.

bit 1: \overline{MS} bit. When 0, does not increment the address; when 1, increments the address in multiple reads.

bit 2-7: address AD(5:0). This is the address field of the indexed register.

bit 8-15: data DO(7:0) (read mode). This is the data that is read from the device (MSb first).

bit 16-... : data DO(...-8). Further data in multiple byte reads.

Figure 8. Multiple byte SPI read protocol (2-byte example)

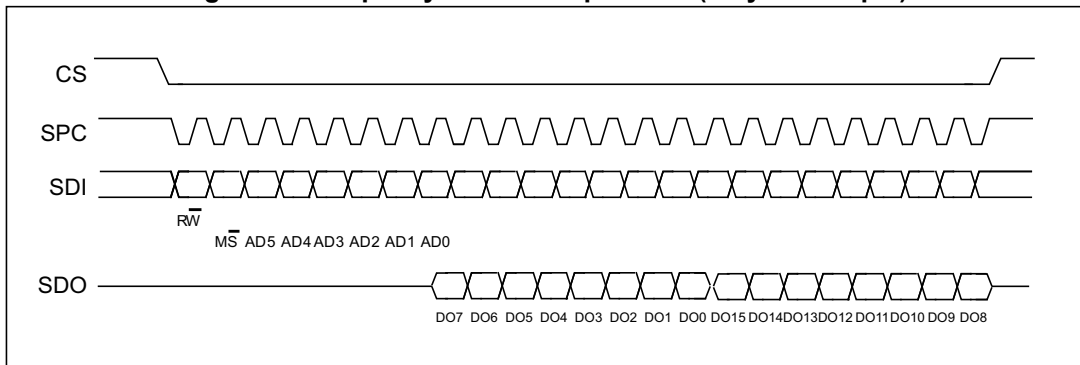

6.2.2 SPI write

Figure 9. SPI write protocol

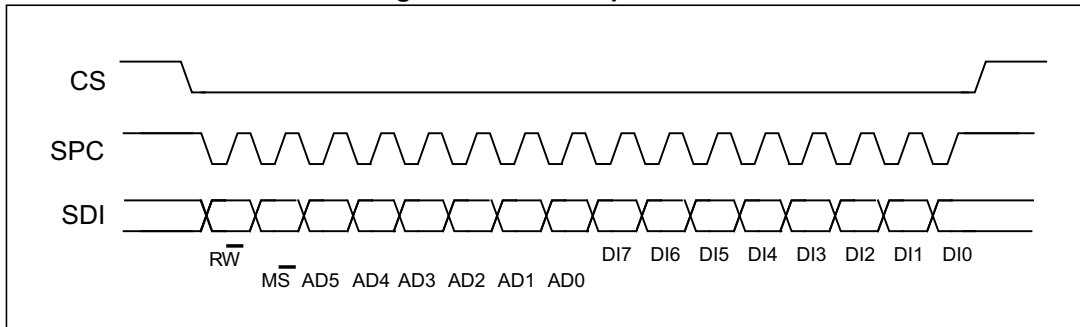

The SPI write command is performed with 16 clock pulses. A multiple byte write command is performed by adding blocks of 8 clock pulses to the previous one.

bit 0: WRITE bit. The value is 0.

bit 1: \overline{MS} bit. When 0, does not increment the address; when 1, increments the address in multiple writes.

bit 2 -7: address AD(5:0). This is the address field of the indexed register.

bit 8-15: data DI(7:0) (write mode). This is the data that is written inside the device (MSb first).

bit 16-... : data DI(...-8). Further data in multiple byte writes.

Figure 10. Multiple byte SPI write protocol (2-byte example)

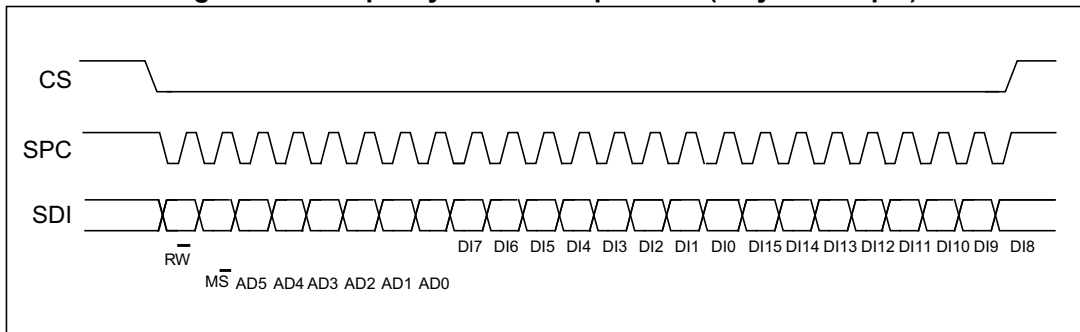

6.2.3 SPI read in 3-wire mode

3-wire mode is entered by setting the bit SIM (SPI serial interface mode selection) to '1' in *CTRL_REG4 (23h)*.

Figure 11. SPI read protocol in 3-wire mode

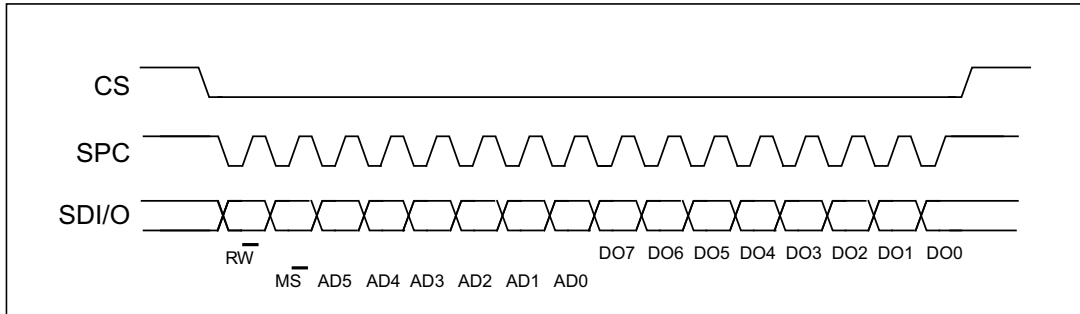

The SPI read command is performed with 16 clock pulses:

bit 0: READ bit. The value is 1.

bit 1: \overline{MS} bit. When 0, does not increment the address; when 1, increments the address in multiple reads.

bit 2-7: address AD(5:0). This is the address field of the indexed register.

bit 8-15: data DO(7:0) (read mode). This is the data that is read from the device (MSb first).

The multiple read command is also available in 3-wire mode.

7 Register mapping

The table given below provides a list of the 8-bit registers embedded in the device and the corresponding addresses.

Table 21. Register address map

Name	Type	Register address		Default	Comment
		Hex	Binary		
Reserved (do not modify)		00 - 06			Reserved
STATUS_REG_AUX	r	07	000 0111	Output	
OUT_ADC1_L	r	08	000 1000	Output	
OUT_ADC1_H	r	09	000 1001	Output	
OUT_ADC2_L	r	0A	000 1010	Output	
OUT_ADC2_H	r	0B	000 1011	Output	
OUT_ADC3_L	r	0C	000 1100	Output	
OUT_ADC3_H	r	0D	000 1101	Output	
Reserved (do not modify)		0E			Reserved
WHO_AM_I	r	0F	000 1111	00110011	Dummy register
Reserved (do not modify)		10 - 1D			Reserved
CTRL_REG0	rw	1E	001 1110	00010000	
TEMP_CFG_REG	rw	1F	001 1111	00000000	
CTRL_REG1	rw	20	010 0000	00000111	
CTRL_REG2	rw	21	010 0001	00000000	
CTRL_REG3	rw	22	010 0010	00000000	
CTRL_REG4	rw	23	010 0011	00000000	
CTRL_REG5	rw	24	010 0100	00000000	
CTRL_REG6	rw	25	010 0101	00000000	
REFERENCE	rw	26	010 0110	00000000	
STATUS_REG	r	27	010 0111	Output	
OUT_X_L	r	28	010 1000	Output	
OUT_X_H	r	29	010 1001	Output	
OUT_Y_L	r	2A	010 1010	Output	
OUT_Y_H	r	2B	010 1011	Output	
OUT_Z_L	r	2C	010 1100	Output	
OUT_Z_H	r	2D	010 1101	Output	
FIFO_CTRL_REG	rw	2E	010 1110	00000000	
FIFO_SRC_REG	r	2F	010 1111	Output	

Table 21. Register address map

Name	Type	Register address		Default	Comment
		Hex	Binary		
INT1_CFG	rw	30	011 0000	00000000	
INT1_SRC	r	31	011 0001	Output	
INT1_THS	rw	32	011 0010	00000000	
INT1_DURATION	rw	33	011 0011	00000000	
INT2_CFG	rw	34	011 0100	00000000	
INT2_SRC	r	35	011 0101	Output	
INT2_THS	rw	36	011 0110	00000000	
INT2_DURATION	rw	37	011 0111	00000000	
CLICK_CFG	rw	38	011 1000	00000000	
CLICK_SRC	r	39	011 1001	Output	
CLICK_THS	rw	3A	011 1010	00000000	
TIME_LIMIT	rw	3B	011 1011	00000000	
TIME_LATENCY	rw	3C	011 1100	00000000	
TIME_WINDOW	rw	3D	011 1101	00000000	
ACT_THS	rw	3E	011 1110	00000000	
ACT_DUR	rw	3F	011 1111	00000000	

Registers marked as *Reserved* or not listed in the table above must not be changed. Writing to those registers may cause permanent damage to the device.

The content of the registers that are loaded at boot should not be changed. They contain the factory calibration values. Their content is automatically restored when the device is powered up.

The boot procedure is complete about 5 milliseconds after device power-up.

8 Registers description

8.1 STATUS_REG_AUX (07h)

Table 22. STATUS_REG_AUX register

321OR	3OR	2OR	1OR	321DA	3DA	2DA	1DA
-------	-----	-----	-----	-------	-----	-----	-----

Table 23. STATUS_REG_AUX description

321OR	1, 2 and 3-axis data overrun. Default value: 0 (0: no overrun has occurred; 1: a new set of data has overwritten the previous set)
3OR	3-axis data overrun. Default value: 0 (0: no overrun has occurred; 1: new data for the 3-axis has overwritten the previous data)
2OR	2-axis data overrun. Default value: 0 (0: no overrun has occurred; 1: new data for the 2-axis has overwritten the previous data)
1OR	1-axis data overrun. Default value: 0 (0: no overrun has occurred; 1: new data for the 1-axis has overwritten the previous data)
321DA	1, 2 and 3-axis new data available. Default value: 0 (0: a new set of data is not yet available; 1: a new set of data is available)
3DA	3-axis new data available. Default value: 0 (0: new data for the 3-axis is not yet available; 1: new data for the 3-axis is available)
2DA	2-axis new data available. Default value: 0 (0: new data for the 2-axis is not yet available; 1: new data for the 2-axis is available)
1DA	1-axis new data available. Default value: 0 (0: new data for the 1-axis is not yet available; 1: new data for the 1-axis is available)

8.2 OUT_ADC1_L (08h), OUT_ADC1_H (09h)

Auxiliary 10-bit ADC channel 1 conversion. For auxiliary ADC setting refer to [Section 3.7: Auxiliary ADC and temperature sensor](#).

8.3 OUT_ADC2_L (0Ah), OUT_ADC2_H (0Bh)

Auxiliary 10-bit ADC channel 2 conversion. For auxiliary ADC setting refer to [Section 3.7: Auxiliary ADC and temperature sensor](#).

8.4 OUT_ADC3_L (0Ch), OUT_ADC3_H (0Dh)

Auxiliary 10-bit ADC channel 3 conversion or temperature sensor data output. Refer to [Section 3.7: Auxiliary ADC and temperature sensor](#).

8.5 WHO_AM_I (0Fh)

Table 24. WHO_AM_I register

0	0	1	1	0	0	1	1
---	---	---	---	---	---	---	---

Device identification register.

8.6 CTRL_REG0 (1Eh)

Table 25. CTRL_REG0 register

SDO_PU_DISC	0 ⁽¹⁾	0 ⁽¹⁾	1 ⁽²⁾	0 ⁽¹⁾	0 ⁽¹⁾	0 ⁽¹⁾	0 ⁽¹⁾
-------------	------------------	------------------	------------------	------------------	------------------	------------------	------------------

1. This bit must be set to 0 for correct operation of the device.
2. This bit must be set to 1 for correct operation of the device.

Table 26. CTRL_REG0 description

SDO_PU_DISC	Disconnect SDO/SA0 pull-up. Default value: 00010000 (0: pull-up connected to SDO/SA0 pin; 1: pull-up disconnected to SDO/SA0 pin)
-------------	---

Note: Leave bits 0 through 6 at the default value in order to ensure correct operation of the device.

8.7 TEMP_CFG_REG (1Fh)

Table 27. TEMP_CFG_REG register

ADC_EN	TEMP_EN	0	0	0	0	0	0
--------	---------	---	---	---	---	---	---

Table 28. TEMP_CFG_REG description

TEMP_EN	Temperature sensor (T) enable. Default value: 0 (0: T disabled; 1: T enabled)
ADC_EN	ADC enable. Default value: 0 (0: ADC disabled; 1: ADC enabled)

8.8 CTRL_REG1 (20h)

Table 29. CTRL_REG1 register

ODR3	ODR2	ODR1	ODR0	LPen	Zen	Yen	Xen
------	------	------	------	------	-----	-----	-----

Table 30. CTRL_REG1 description

ODR[3:0]	Data rate selection. Default value: 0000 (0000: power-down mode; others: Refer to Table 31: Data rate configuration)
LPen	Low-power mode enable. Default value: 0 (0: high-resolution mode / normal mode, 1: low-power mode) (Refer to section Section 3.2.1: High-resolution, normal mode, low-power mode)
Zen	Z-axis enable. Default value: 1 (0: Z-axis disabled; 1: Z-axis enabled)
Yen	Y-axis enable. Default value: 1 (0: Y-axis disabled; 1: Y-axis enabled)
Xen	X-axis enable. Default value: 1 (0: X-axis disabled; 1: X-axis enabled)

ODR[3:0] is used to set the power mode and ODR selection. The following table indicates the frequency of each combination of ODR[3:0].

Table 31. Data rate configuration

ODR3	ODR2	ODR1	ODR0	Power mode selection
0	0	0	0	Power-down mode
0	0	0	1	HR / Normal / Low-power mode (1 Hz)
0	0	1	0	HR / Normal / Low-power mode (10 Hz)
0	0	1	1	HR / Normal / Low-power mode (25 Hz)
0	1	0	0	HR / Normal / Low-power mode (50 Hz)
0	1	0	1	HR / Normal / Low-power mode (100 Hz)
0	1	1	0	HR / Normal / Low-power mode (200 Hz)
0	1	1	1	HR / Normal / Low-power mode (400 Hz)
1	0	0	0	Low power mode (1.60 kHz)
1	0	0	1	HR / normal (1.344 kHz); Low-power mode (5.376 kHz)

8.9 CTRL_REG2 (21h)

Table 32. CTRL_REG2 register

HPM1	HPM0	HPCF2	HPCF1	FDS	HPCLICK	HP_IA2	HP_IA1
------	------	-------	-------	-----	---------	--------	--------

Table 33. CTRL_REG2 description

HPM[1:0]	High-pass filter mode selection. Default value: 00 Refer to Table 34: High-pass filter mode configuration
HPCF[2:1]	High-pass filter cutoff frequency selection
FDS	Filtered data selection. Default value: 0 (0: internal filter bypassed; 1: data from internal filter sent to output register and FIFO)
HPCLICK	High-pass filter enabled for CLICK function. (0: filter bypassed; 1: filter enabled)
HP_IA2	High-pass filter enabled for AOI function on interrupt 2, (0: filter bypassed; 1: filter enabled)
HP_IA1	High-pass filter enabled for AOI function on interrupt 1, (0: filter bypassed; 1: filter enabled)

Table 34. High-pass filter mode configuration

HPM1	HPM0	High-pass filter mode
0	0	Normal mode (reset by reading REFERENCE (26h))
0	1	Reference signal for filtering
1	0	Normal mode
1	1	Autoreset on interrupt event

8.10 CTRL_REG3 (22h)

Table 35. CTRL_REG3 register

I1_CLICK	I1_IA1	I1_IA2	I1_ZYXDA	I1_321DA	I1_WTM	I1_OVERRUN	--
----------	--------	--------	----------	----------	--------	------------	----

Table 36. CTRL_REG3 description

I1_CLICK	Click interrupt on INT1. Default value: 0 (0: disable; 1: enable)
I1_IA1	IA1 interrupt on INT1. Default value: 0 (0: disable; 1: enable)
I1_IA2	IA2 interrupt on INT1. Default value: 0 (0: disable; 1: enable)
I1_ZYXDA	ZYXDA interrupt on INT1. Default value: 0 (0: disable; 1: enable)
I1_321DA	321DA interrupt on INT1. Default value: 0 (0: disable; 1: enable)
I1_WTM	FIFO watermark interrupt on INT1. Default value: 0 (0: disable; 1: enable)
I1_OVERRUN	FIFO overrun interrupt on INT1. Default value: 0 (0: disable; 1: enable)

8.11 CTRL_REG4 (23h)

Table 37. CTRL_REG4 register

BDU	BLE ⁽¹⁾	FS1	FS0	HR	ST1	ST0	SIM
-----	--------------------	-----	-----	----	-----	-----	-----

1. The BLE function can be activated only in high-resolution mode.

Table 38. CTRL_REG4 description

BDU	Block data update. Default value: 0 (0: continuous update; 1: output registers not updated until MSB and LSB reading)
BLE	Big/little endian data selection. Default value 0. (0: Data LSB @ lower address; 1: Data MSB @ lower address)
FS[1:0]	Full-scale selection. default value: 00 (00: $\pm 2 g$; 01: $\pm 4 g$; 10: $\pm 8 g$; 11: $\pm 16 g$)
HR	High-resolution output mode: Default value: 0 (0: high-resolution disabled; 1: high-resolution enabled)
ST[1:0]	Self-test enable. Default value: 00 (00: self-test disabled; other: See Table 39)
SIM	SPI serial interface mode selection. Default value: 0 (0: 4-wire interface; 1: 3-wire interface)

Table 39. Self-test mode configuration

ST1	ST0	Self test mode
0	0	Normal mode
0	1	Self-test 0
1	0	Self-test 1
1	1	--

8.12 CTRL_REG5 (24h)

Table 40. CTRL_REG5 register

BOOT	FIFO_EN	--	--	LIR_INT1	D4D_INT1	LIR_INT2	D4D_INT2
------	---------	----	----	----------	----------	----------	----------

Table 41. CTRL_REG5 description

BOOT	Reboot memory content. Default value: 0 (0: normal mode; 1: reboot memory content)
FIFO_EN	FIFO enable. Default value: 0 (0: FIFO disable; 1: FIFO enable)
LIR_INT1	Latch interrupt request on INT1_SRC register, with <i>INT1_SRC (31h)</i> register cleared by reading <i>INT1_SRC (31h)</i> itself. Default value: 0. (0: interrupt request not latched; 1: interrupt request latched)
D4D_INT1	4D enable: 4D detection is enabled on INT1 when 6D bit on INT1_CFG is set to 1.
LIR_INT2	Latch interrupt request on <i>INT2_SRC (35h)</i> register, with <i>INT2_SRC (35h)</i> register cleared by reading <i>INT2_SRC (35h)</i> itself. Default value: 0 (0: interrupt request not latched; 1: interrupt request latched)
D4D_INT2	4D enable: 4D detection is enabled on INT2 pin when 6D bit on <i>INT2_CFG (34h)</i> is set to 1.

8.13 CTRL_REG6 (25h)

Table 42. CTRL_REG6 register

I2_CLICK	I2_IA1	I2_IA2	I2_BOOT	I2_ACT	--	INT_POLARITY	-
----------	--------	--------	---------	--------	----	--------------	---

Table 43. CTRL_REG6 description

I2_CLICK	Click interrupt on INT2 pin. Default value: 0 (0: disabled; 1: enabled)
I2_IA1	Enable interrupt 1 function on INT2 pin. Default value: 0 (0: function disabled; 1: function enabled)
I2_IA2	Enable interrupt 2 function on INT2 pin. Default value: 0 (0: function disabled; 1: function enabled)
I2_BOOT	Enable boot on INT2 pin. Default value: 0 (0: disabled; 1: enabled)
I2_ACT	Enable activity interrupt on INT2 pin. Default value: 0 (0: disabled; 1: enabled)
INT_POLARITY	INT1 and INT2 pin polarity. Default value: 0 (0: active-high; 1: active-low)

8.14 REFERENCE (26h)

Table 44. REFERENCE register

Ref7	Ref6	Ref5	Ref4	Ref3	Ref2	Ref1	Ref0
------	------	------	------	------	------	------	------

Table 45. REFERENCE register description

Ref[7:0]	Reference value for Interrupt generation. Default value: 0000 0000
----------	--

8.15 STATUS_REG (27h)

Table 46. STATUS register

ZYXOR	ZOR	YOR	XOR	ZYXDA	ZDA	YDA	XDA
-------	-----	-----	-----	-------	-----	-----	-----

Table 47. STATUS register description

ZYXOR	X, Y and Z-axis data overrun. Default value: 0 (0: no overrun has occurred; 1: a new set of data has overwritten the previous set)
ZOR	Z-axis data overrun. Default value: 0 (0: no overrun has occurred; 1: a new data for the Z-axis has overwritten the previous data)
YOR	Y-axis data overrun. Default value: 0 (0: no overrun has occurred; 1: new data for the Y-axis has overwritten the previous data)
XOR	X-axis data overrun. Default value: 0 (0: no overrun has occurred; 1: new data for the X-axis has overwritten the previous data)
ZYXDA	X, Y and Z-axis new data available. Default value: 0 (0: a new set of data is not yet available; 1: a new set of data is available)
ZDA	Z-axis new data available. Default value: 0 (0: new data for the Z-axis is not yet available; 1: new data for the Z-axis is available)
YDA	Y-axis new data available. Default value: 0 (0: new data for the Y-axis is not yet available; 1: new data for the Y-axis is available)

8.16 OUT_X_L (28h), OUT_X_H (29h)

X-axis acceleration data. The value is expressed as two's complement left-justified. Please refer to [Section 3.2.1: High-resolution, normal mode, low-power mode](#).

8.17 OUT_Y_L (2Ah), OUT_Y_H (2Bh)

Y-axis acceleration data. The value is expressed as two's complement left-justified. Please refer to [Section 3.2.1: High-resolution, normal mode, low-power mode](#).

8.18 OUT_Z_L (2Ch), OUT_Z_H (2Dh)

Z-axis acceleration data. The value is expressed as two's complement left-justified. Please refer to [Section 3.2.1: High-resolution, normal mode, low-power mode](#).

8.19 FIFO_CTRL_REG (2Eh)

Table 48. REFERENCE register

FM1	FM0	TR	FTH4	FTH3	FTH2	FTH1	FTH0
-----	-----	----	------	------	------	------	------

Table 49. REFERENCE register description

FM[1:0]	FIFO mode selection. Default value: 00 (see Table 50)
TR	Trigger selection. Default value: 0 (0: trigger event allows triggering signal on INT1 1: trigger event allows triggering signal on INT2)
FTH[4:0]	Default value: 00000

Table 50. FIFO mode configuration

FM1	FM0	Self test mode
0	0	Bypass mode
0	1	FIFO mode
1	0	Stream mode
1	1	Stream-to-FIFO

8.20 FIFO_SRC_REG (2Fh)

Table 51. FIFO_SRC_REG register

WTM	OVRN_FIFO	EMPTY	FSS4	FSS3	FSS2	FSS1	FSS0
-----	-----------	-------	------	------	------	------	------

Table 52. FIFO_SRC_REG description

WTM	WTM bit is set high when FIFO content exceeds watermark level
OVRN_FIFO	OVRN bit is set high when FIFO buffer is full; this means that the FIFO buffer contains 32 unread samples. At the following ODR a new sample set replaces the oldest FIFO value. The OVRN bit is set to 0 when the first sample set has been read
EMPTY	EMPTY flag is set high when all FIFO samples have been read and FIFO is empty
FSS [4:0]	FSS [4:0] field always contains the current number of unread samples stored in the FIFO buffer. When FIFO is enabled, this value increases at ODR frequency until the buffer is full, whereas, it decreases every time one sample set is retrieved from FIFO.

8.21 INT1_CFG (30h)

Table 53. INT1_CFG register

AOI	6D	ZHIE	ZLIE	YHIE	YLIE	XHIE	XLIE
-----	----	------	------	------	------	------	------

Table 54. INT1_CFG description

AOI	And/Or combination of Interrupt events. Default value: 0 Refer to Table 55: Interrupt mode
6D	6 direction detection function enabled. Default value: 0Refer to Table 55: Interrupt mode
ZHIE	Enable interrupt generation on Z high event or on Direction recognition. Default value: 0 (0: disable interrupt request;1: enable interrupt request)
ZLIE	Enable interrupt generation on Z low event or on Direction recognition. Default value: 0 (0: disable interrupt request;1: enable interrupt request)
YHIE	Enable interrupt generation on Y high event or on Direction recognition. Default value: 0 (0: disable interrupt request; 1: enable interrupt request.)
YLIE	Enable interrupt generation on Y low event or on Direction recognition. Default value: 0 (0: disable interrupt request; 1: enable interrupt request.)
XHIE	Enable interrupt generation on X high event or on Direction recognition. Default value: 0 (0: disable interrupt request; 1: enable interrupt request.)
XLIE	Enable interrupt generation on X low event or on Direction recognition. Default value: 0 (0: disable interrupt request; 1: enable interrupt request.)

Content of this register is loaded at boot.

Write operation at this address is possible only after system boot.

Table 55. Interrupt mode

AOI	6D	Interrupt mode
0	0	OR combination of interrupt events
0	1	6-direction movement recognition
1	0	AND combination of interrupt events
1	1	6-direction position recognition

Difference between AOI-6D = '01' and AOI-6D = '11'.

AOI-6D = '01' is movement recognition. An interrupt is generated when the orientation moves from an unknown zone to known zone. The interrupt signal remains for a duration ODR.

AOI-6D = '11' is direction recognition. An interrupt is generated when the orientation is inside a known zone. The interrupt signal remains until the orientation is inside the zone.

8.22 INT1_SRC (31h)

Table 56. INT1_SRC register

0	IA	ZH	ZL	YH	YL	XH	XL
---	----	----	----	----	----	----	----

Table 57. INT1_SRC description

IA	Interrupt active. Default value: 0 (0: no interrupt has been generated; 1: one or more interrupts have been generated)
ZH	Z high. Default value: 0 (0: no interrupt, 1: Z high event has occurred)
ZL	Z low. Default value: 0 (0: no interrupt; 1: Z low event has occurred)
YH	Y high. Default value: 0 (0: no interrupt, 1: Y high event has occurred)
YL	Y low. Default value: 0 (0: no interrupt, 1: Y low event has occurred)
XH	X high. Default value: 0 (0: no interrupt, 1: X high event has occurred)
XL	X low. Default value: 0 (0: no interrupt, 1: X low event has occurred)

Interrupt 1 source register. Read-only register.

Reading at this address clears the *INT1_SRC (31h)* IA bit (and the interrupt signal on the INT 1 pin) and allows the refresh of data in *INT1_SRC (31h)* if the latched option was chosen.

8.23 INT1_THS (32h)

Table 58. INT1_THS register

0	THS6	THS5	THS4	THS3	THS2	THS1	THS0
---	------	------	------	------	------	------	------

Table 59. INT1_THS description

THS[6:0]	Interrupt 1 threshold. Default value: 000 0000 1 LSb = 16 mg @ FS = ± 2 g 1 LSb = 32 mg @ FS = ± 4 g 1 LSb = 62 mg @ FS = ± 8 g 1 LSb = 186 mg @ FS = ± 16 g
----------	--

8.24 INT1_DURATION (33h)

Table 60. INT1_DURATION register

0	D6	D5	D4	D3	D2	D1	D0
---	----	----	----	----	----	----	----

Table 61. INT1_DURATION description

D[6:0]	Duration value. Default value: 000 0000 1 LSb = 1/ODR
--------	--

The **D[6:0]** bits set the minimum duration of the Interrupt 2 event to be recognized. Duration steps and maximum values depend on the ODR chosen.

Duration time is measured in N/ODR, where N is the content of the duration register.

8.25 INT2_CFG (34h)

Table 62. INT2_CFG register

AOI	6D	ZHIE	ZLIE	YHIE	YLIE	XHIE	XLIE
-----	----	------	------	------	------	------	------

Table 63. INT2_CFG description

AOI	AND/OR combination of interrupt events. Default value: 0 (see Table 64)
6D	6-direction detection function enabled. Default value: 0. Refer to Table 64 .
ZHIE	Enable interrupt generation on Z high event. Default value: 0 (0: disable interrupt request; 1: enable interrupt request on measured accel. value higher than preset threshold)
ZLIE	Enable interrupt generation on Z low event. Default value: 0 (0: disable interrupt request; 1: enable interrupt request on measured accel. value lower than preset threshold)
YHIE	Enable interrupt generation on Y high event. Default value: 0 (0: disable interrupt request; 1: enable interrupt request on measured accel. value higher than preset threshold)
YLIE	Enable interrupt generation on Y low event. Default value: 0 (0: disable interrupt request; 1: enable interrupt request on measured accel. value lower than preset threshold)
XHIE	Enable interrupt generation on X high event. Default value: 0 (0: disable interrupt request; 1: enable interrupt request on measured accel. value higher than preset threshold)
XLIE	Enable interrupt generation on X low event. Default value: 0 (0: disable interrupt request; 1: enable interrupt request on measured accel. value lower than preset threshold)

The content of this register is loaded at boot.

A write operation to this address is possible only after system boot.

Table 64. Interrupt mode

AOI	6D	Interrupt mode
0	0	OR combination of interrupt events
0	1	6-direction movement recognition
1	0	AND combination of interrupt events
1	1	6-direction position recognition

The difference between AOI-6D = '01' and AOI-6D = '11'.

AOI-6D = '01' is movement recognition. An interrupt is generated when the orientation moves from an unknown zone to a known zone. The interrupt signal remains for a duration ODR.

AOI-6D = '11' is direction recognition. An interrupt is generated when the orientation is inside a known zone. The interrupt signal remains while the orientation is inside the zone.

8.26 INT2_SRC (35h)

Table 65. INT2_SRC register

0	IA	ZH	ZL	YH	YL	XH	XL
---	----	----	----	----	----	----	----

Table 66. INT2_SRC description

IA	Interrupt active. Default value: 0 (0: no interrupt has been generated; 1: one or more interrupts have been generated)
ZH	Z high. Default value: 0 (0: no interrupt, 1: Z high event has occurred)
ZL	Z low. Default value: 0 (0: no interrupt; 1: Z low event has occurred)
YH	Y high. Default value: 0 (0: no interrupt, 1: Y high event has occurred)
YL	Y low. Default value: 0 (0: no interrupt, 1: Y low event has occurred)
XH	X high. Default value: 0 (0: no interrupt, 1: X high event has occurred)
XL	X low. Default value: 0 (0: no interrupt, 1: X low event has occurred)

Interrupt 2 source register. Read-only register.

Reading at this address clears the *INT2_SRC (35h)* IA bit (and the interrupt signal on the INT2 pin) and allows the refresh of data in the *INT2_SRC (35h)* register if the latched option was chosen.

8.27 INT2_THS (36h)

Table 67. INT2_THS register

0	THS6	THS5	THS4	THS3	THS2	THS1	THS0
---	------	------	------	------	------	------	------

Table 68. INT2_THS description

THS[6:0]	Interrupt 2 threshold. Default value: 000 0000 1 LSb = 16 mg @ FS = ±2 g 1 LSb = 32 mg @ FS = ±4 g 1 LSb = 62 mg @ FS = ±8 g 1 LSb = 186 mg @ FS = ±16 g
----------	--

8.28 INT2_DURATION (37h)

Table 69. INT2_DURATION register

0	D6	D5	D4	D3	D2	D1	D0
---	----	----	----	----	----	----	----

Table 70. INT2_DURATION description

D[6:0]	Duration value. Default value: 000 0000 1 LSb = 1/ODR ⁽¹⁾
--------	---

1. Duration time is measured in N/ODR, where N is the content of the duration register.

The **D[6:0]** bits set the minimum duration of the Interrupt 2 event to be recognized. Duration time steps and maximum values depend on the ODR chosen.

8.29 CLICK_CFG (38h)

Table 71. CLICK_CFG register

--	--	zd	zs	yd	ys	xd	xs
----	----	----	----	----	----	----	----

Table 72. CLICK_CFG description

ZD	Enable interrupt double click on Z-axis. Default value: 0 (0: disable interrupt request; 1: enable interrupt request on measured accel. value higher than preset threshold)
ZS	Enable interrupt single click on Z-axis. Default value: 0 (0: disable interrupt request; 1: enable interrupt request on measured accel. value higher than preset threshold)
YD	Enable interrupt double click on Y-axis. Default value: 0 (0: disable interrupt request; 1: enable interrupt request on measured accel. value higher than preset threshold)
YS	Enable interrupt single click on Y-axis. Default value: 0 (0: disable interrupt request; 1: enable interrupt request on measured accel. value higher than preset threshold)
XD	Enable interrupt double click on X-axis. Default value: 0 (0: disable interrupt request; 1: enable interrupt request on measured accel. value higher than preset threshold)
XS	Enable interrupt single click on X-axis. Default value: 0 (0: disable interrupt request; 1: enable interrupt request on measured accel. value higher than preset threshold)

8.30 CLICK_SRC (39h)

Table 73. CLICK_SRC register

	IA	DCLICK	SCLICK	Sign	Z	Y	X
--	----	--------	--------	------	---	---	---

Table 74. CLICK_SRC description

IA	Interrupt active. Default value: 0 (0: no interrupt has been generated; 1: one or more interrupts have been generated)
DCLICK	Double-click enable. Default value: 0 (0: double-click detection disabled, 1: double-click detection enabled)
SCLICK	Single-click enable. Default value: 0 (0: Single-click detection disabled, 1: single-click detection enabled)
Sign	Click sign. (0: positive detection, 1: negative detection)
Z	Z click detection. Default value: 0 (0: no interrupt, 1: Z high event has occurred)
Y	Y click detection. Default value: 0 (0: no interrupt, 1: Y high event has occurred)
X	X click detection. Default value: 0 (0: no interrupt, 1: X high event has occurred)

8.31 CLICK_THS (3Ah)

Table 75. CLICK_THS register

LIR_Click	Ths6	Ths5	Ths4	Ths3	Ths2	Ths1	Ths0
-----------	------	------	------	------	------	------	------

Table 76. CLICK_SRC description

LIR_Click	If the LIR_Click bit is not set, the interrupt is kept high for the duration of the latency window. If the LIR_Click bit is set, the interrupt is kept high until the CLICK_SRC (39h) register is read.
Ths[6:0]	Click threshold. Default value: 000 0000

8.32 TIME_LIMIT (3Bh)

Table 77. TIME_LIMIT register

-	TLI6	TLI5	TLI4	TLI3	TLI2	TLI1	TLI0
---	------	------	------	------	------	------	------

Table 78. TIME_LIMIT description

TLI[6:0]	Click time limit. Default value: 000 0000
----------	---

8.33 TIME_LATENCY (3Ch)

Table 79. TIME_LATENCY register

TLA7	TLA6	TLA5	TLA4	TLA3	TLA2	TLA1	TLA0
------	------	------	------	------	------	------	------

Table 80. TIME_LATENCY description

TLA[7:0]	Click time latency. Default value: 0000 0000
----------	--

8.34 TIME_WINDOW (3Dh)

Table 81. TIME_WINDOW register

TW7	TW6	TW5	TW4	TW3	TW2	TW1	TW0
-----	-----	-----	-----	-----	-----	-----	-----

Table 82. TIME_WINDOW description

TW[7:0]	Click time window
---------	-------------------

8.35 ACT_THS (3Eh)

Table 83. ACT_THS register

--	Acth6	Acth5	Acth4	Acth3	Acth2	Acth1	Acth0
----	-------	-------	-------	-------	-------	-------	-------

Table 84. ACT_THS description

Acth[6:0]	Sleep-to-wake, return-to-sleep activation threshold in low-power mode 1 LSb = 16 mg @ FS = ±2 g 1 LSb = 32 mg @ FS = ±4 g 1 LSb = 62 mg @ FS = ±8 g 1 LSb = 186 mg @ FS = ±16 g
-----------	---

8.36 ACT_DUR (3Fh)

Table 85. ACT_DUR register

ActD7	ActD6	ActD5	ActD4	ActD3	ActD2	ActD1	ActD0
-------	-------	-------	-------	-------	-------	-------	-------

Table 86. ACT_DUR description

ActD[7:0]	Sleep-to-wake, return-to-sleep duration 1 LSb = (8*1[LSb]+1)/ODR
-----------	---

9 Package information

In order to meet environmental requirements, ST offers these devices in different grades of ECOPACK[®] packages, depending on their level of environmental compliance. ECOPACK[®] specifications, grade definitions and product status are available at: www.st.com. ECOPACK is an ST trademark.

9.2 LGA-16 packing information

Figure 13. Carrier tape information for LGA-16 package

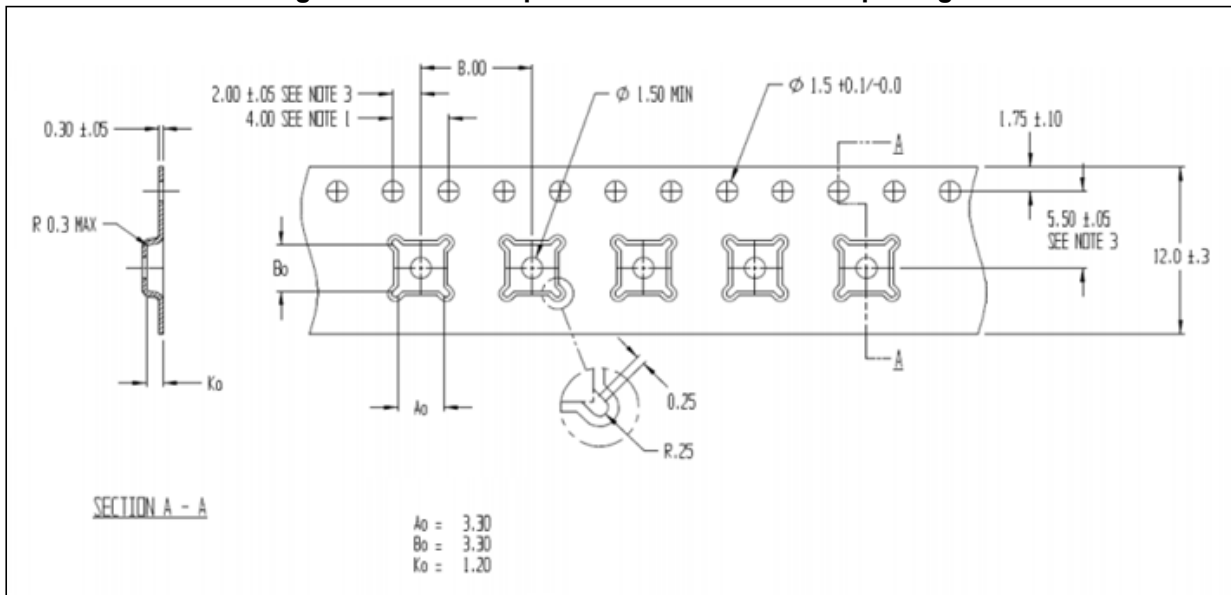

Figure 14. LGA-16 package orientation in carrier tape

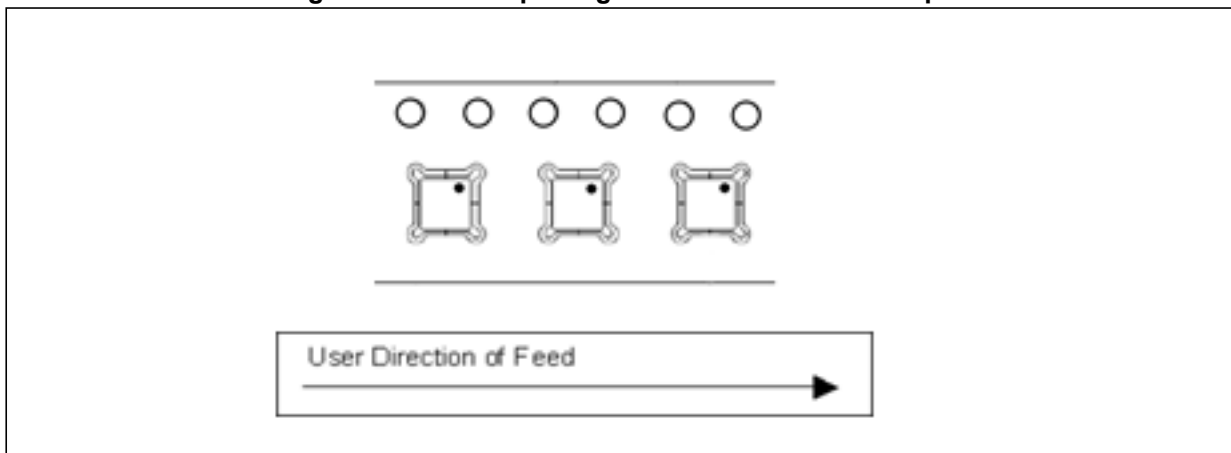

Figure 15. Reel information for carrier tape of LGA-16 package

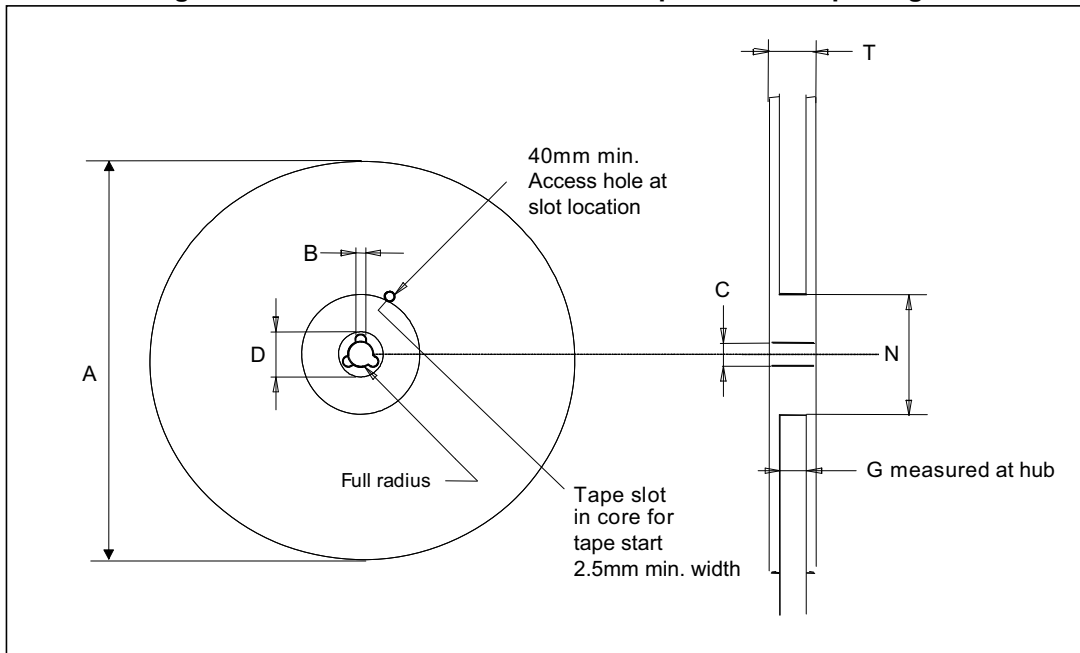

Table 87. Reel dimensions for carrier tape of LGA-16 package

Reel dimensions (mm)	
A (max)	330
B (min)	1.5
C	13 ±0.25
D (min)	20.2
N (min)	60
G	12.4 +2/-0
T (max)	18.4

10 Revision history

Table 88. Document revision history

Date	Revision	Changes
21-May-2010	1	Initial release
12-Dec-2016	2	Updated <i>Table 1: Device summary</i> Updated <i>Features</i> and <i>Figure 1: Block diagram</i> Updated <i>Table 2: Pin description</i> and <i>Table 14: Serial interface pin description</i> Added <i>Table 3: Internal pull-up values (typ.) for SDO/SA0 pin</i> Updated <i>Table 9: Absolute maximum ratings</i> Updated <i>Section 3.7: Auxiliary ADC and temperature sensor</i> Updated <i>Section 4: Application hints</i> Updated <i>Section 5: Digital main blocks</i> Updated <i>Section 7: Register mapping</i> and <i>Section 8: Registers description</i> Updated <i>Section 9.1: LGA-16 package information</i> Added <i>Section 9.2: LGA-16 packing information</i> Minor textual updates

IMPORTANT NOTICE – PLEASE READ CAREFULLY

STMicroelectronics NV and its subsidiaries (“ST”) reserve the right to make changes, corrections, enhancements, modifications, and improvements to ST products and/or to this document at any time without notice. Purchasers should obtain the latest relevant information on ST products before placing orders. ST products are sold pursuant to ST’s terms and conditions of sale in place at the time of order acknowledgement.

Purchasers are solely responsible for the choice, selection, and use of ST products and ST assumes no liability for application assistance or the design of Purchasers’ products.

No license, express or implied, to any intellectual property right is granted by ST herein.

Resale of ST products with provisions different from the information set forth herein shall void any warranty granted by ST for such product.

ST and the ST logo are trademarks of ST. All other product or service names are the property of their respective owners.

Information in this document supersedes and replaces information previously supplied in any prior versions of this document.

© 2016 STMicroelectronics – All rights reserved