

SECTION X-X

FCI  
FCIconnect.com

Copyright FCI

mat'l. code		surface ISO 1302 ✓		tolerance ISO 406 ISO 1101		projection INCH/MM		product family CLINCHER	
ltr ecn nodr date		tolerances unless otherwise specified		title		dwg no		sheet 1 of 6 size	
A	V03-0423	TAB	4/17/03	angles	line	XXX±.01/0.XX±0.3	scale 3:1	LATCHING CLINCHER™ RECEPTACLE ASSEMBLY	
B	M05-0087	MHT	6/15/05	0°±2'		XXX±.005/0.XX±0.13		10022753 A3	
C	M06-0001	MHT	1/03/06			XXX±.0020/0.XXX±0.051		type Product Customer Drawing	
D	M06-0233	AGS	06/12/06	chr	T. BRUNGARD	4/17/03			
E	M07-0170	MHT	3/30/07	engr	H. SUNDY	4/17/03			
F	ELX-N-010491	ZK	06/03/12	chr	H. SUNDY	4/17/03			
sheet index		revision		appd		H. SUNDY		4/17/03	
		F	F	F	F	F	F		
		1	2	3	4	5	6		

PLATING AVAILABLE

PLATING CODE	TERMINAL	SPRING
1	100u"/2.54u MIN. THICK PURE TIN	10u"/.25u MIN. THICK PURE TIN
2	30u"/.76u MIN. GOLD OR GXT STRIPE IN BOX AREA	NOTE 10 3u"/.08u MIN. GOLD OVER 50u"/1.27u MIN. NICKLE

PRODUCT NUMBER  
10022753-XXXLF

LEAD FREE OPTION  
NOTE 7,8  
NO OF POSITIONS  
AND PLATING  
BASE PART NUMBER

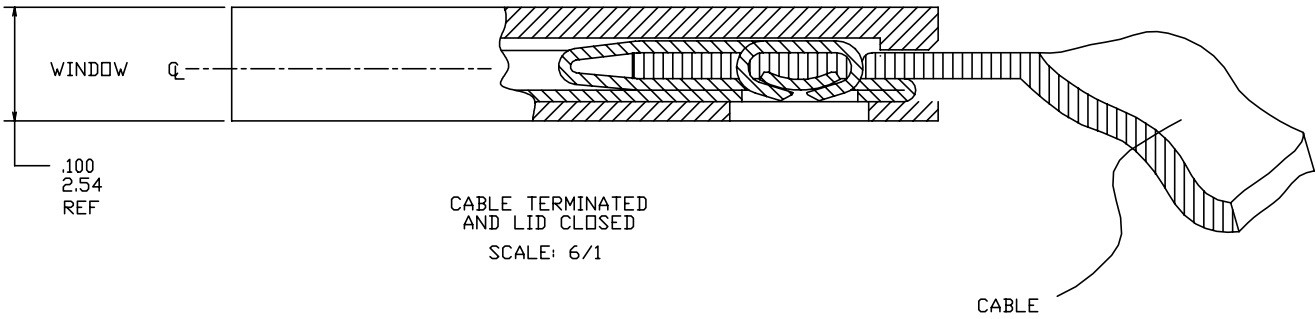

NOTES:

- ① MOLDING MAT'L: THERMOPLASTIC, FLAME RETARDENT PER UL 94V-0. COLOR: BLUE.
- ② TERMINAL MAT'L: 1/2 HARD CuNi ALLOY, UNS-C72500. PLATING: SEE TABULATION AND PLATING TABLE.
- ③ SPRING MAT'L: 1/2 HARD BeCu ALLOY, UNS-C17200. PLATING: SEE TABULATION AND PLATING TABLE.
- ④ LATCH SWINGS CLOSED AFTER TERMINATION MAINTAINING A MAX OVER ALL HEIGHT OF .100/2.54
- ⑤ LABEL IN THIS AREA P/N AND DATE LOT CODE (WEEK AND YEAR) ON DASH No.-067 AND -167 ONLY.
- ⑥ KNURL MARK INDICATES FOR USE WITH INK TERMINATION. CONSULT WITH BERG ELECTRONICS TECHNICAL REPRESENTATIVE FOR SPECIFIC APPLICATIONS.
- ⑦ ADD "LF" SUFFIX AT THE END OF PART NUMBER FOR LEAD FREE OPTION.
- ⑧ THIS PRODUCT MEETS EUROPEAN UNION DIRECTIVES AND OTHER COUNTRY REGULATION AS DESCRIBED IN GS-22-008.
- ⑨ THE PRODUCT IS NOT INTENDED TO BE EXPOSED TO A MANUFACTURING SOLDER PROCESS
- ⑩ PLATING OPTION MAY BE EITHER GOLD OR GXT PLATED AT MANUFACTURER'S OPTION.

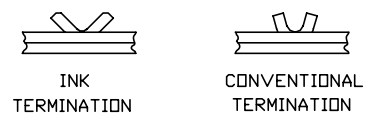

DETAIL Z  
SCALE 6/1

mat'l. code		surface ISO 1302 ✓	tolerance ISO 406 ISO 1101	projection ⊙ ◁	product family CLINCHER
ltr	ecn	nodr	date	title	
F				LATCHING CLINCHER™ RECEPTACLE ASSEMBLY	
tolerances unless otherwise specified				INCH/MM	scale 1:1
angles	line				
0°±2'					
dr	T. BRUNGARD	4/17/03		dwg no	
engr	H. SUNDY	4/17/03		sheet 2 of 6	
chr	H. SUNDY	4/17/03		size	
appd	H. SUNDY	4/17/03		A3	
				type Product Customer Drawing	
sheet index	revision sheet				

PRODUCT NO.	NO. OF POSITIONS	DIM. L ENGLISH	DIM. L METRIC	DIM. M ENGLISH	DIM. M METRIC	DIM. C ENGLISH	DIM. C METRIC	PLATING CODE	TERMINATION NOTE 6
10022753-006	6	0.500	12.70	0.790	20.07	0.715	18.16	1	CONVENTIONAL
10022753-007	7	0.600	15.24	0.890	22.61	0.815	20.70	1	CONVENTIONAL
10022753-008	8	0.700	17.78	0.990	25.15	0.915	23.24	1	CONVENTIONAL
10022753-009	9	0.800	20.32	1.090	27.69	1.015	25.78	1	CONVENTIONAL
10022753-010	10	0.900	22.86	1.190	30.23	1.115	28.32	1	CONVENTIONAL
10022753-011	11	1.000	25.40	1.290	32.77	1.215	30.86	1	CONVENTIONAL
10022753-012	12	1.100	27.94	1.390	35.31	1.315	33.40	1	CONVENTIONAL
10022753-013	13	1.200	30.48	1.490	37.85	1.415	35.94	1	CONVENTIONAL
10022753-014	14	1.300	33.02	1.590	40.39	1.515	38.48	1	CONVENTIONAL
10022753-015	15	1.400	35.56	1.690	42.93	1.615	41.02	1	CONVENTIONAL
10022753-016	16	1.500	38.10	1.790	45.47	1.715	43.56	1	CONVENTIONAL
10022753-017	17	1.600	40.64	1.890	48.01	1.815	46.10	1	CONVENTIONAL
10022753-018	18	1.700	43.18	1.990	50.55	1.915	48.64	1	CONVENTIONAL
10022753-019	19	1.800	45.72	2.090	53.09	2.015	51.18	1	CONVENTIONAL
10022753-020	20	1.900	48.26	2.190	55.63	2.115	53.72	1	CONVENTIONAL
10022753-021	21	2.000	50.80	2.290	58.17	2.215	56.26	1	CONVENTIONAL
10022753-022	22	2.100	53.34	2.390	60.71	2.315	58.80	1	CONVENTIONAL
10022753-023	23	2.200	55.88	2.490	63.25	2.415	61.34	1	CONVENTIONAL
10022753-024	24	2.300	58.42	2.590	65.79	2.515	63.88	1	CONVENTIONAL
10022753-025	25	2.400	60.96	2.690	68.33	2.615	66.42	1	CONVENTIONAL
10022753-026	26	2.500	63.50	2.790	70.87	2.715	68.96	1	CONVENTIONAL
10022753-027	27	2.600	66.04	2.890	73.41	2.815	71.50	1	CONVENTIONAL
10022753-028	28	2.700	68.58	2.990	75.95	2.915	74.04	1	CONVENTIONAL
10022753-029	29	2.800	71.12	3.090	78.49	3.015	76.58	1	CONVENTIONAL
10022753-030	30	2.900	73.66	3.190	81.03	3.115	79.12	1	CONVENTIONAL
10022753-031	31	3.000	76.20	3.290	83.57	3.215	81.66	1	CONVENTIONAL
10022753-032	32	3.100	78.74	3.390	86.11	3.315	84.20	1	CONVENTIONAL
10022753-033	33	3.200	81.28	3.490	88.65	3.415	86.74	1	CONVENTIONAL
10022753-034	34	3.300	83.82	3.590	91.19	3.515	89.28	1	CONVENTIONAL

mat'l. code		surface ISO 1302 ✓	tolerance ISO 406 ISO 1101	projection 	product family CLINCHER
ltr	ecn	nodr	date	title LATCHING CLINCHER™ RECEPTACLE ASSEMBLY	
F				angles 0°±2'	linea XXX±.005/0.XXX±0.13 XXXX±.0020/0.XXX±0.051
				scale 1:1	
				dr T. BRUNGARD 4/17/03	dwg no 10022753
				engr H. SUNDY 4/17/03	sheet 3 of 6 A3
				chr H. SUNDY 4/17/03	type Product Customer Drawing
				appd H. SUNDY 4/17/03	
sheet index	revision sheet				



Copyright FCI

PRODUCT NO.	NO. OF POSITIONS	DIM. L ENGLISH	DIM. L METRIC	DIM. M ENGLISH	DIM. M METRIC	DIM. C ENGLISH	DIM. C METRIC	PLATING CODE	TERMINATION NOTE 6
10022753-039	6	0.500	12.70	0.790	20.07	0.715	18.16	2	CONVENTIONAL
10022753-040	7	0.600	15.24	0.890	22.61	0.815	20.70	2	CONVENTIONAL
10022753-041	8	0.700	17.78	0.990	25.15	0.915	23.24	2	CONVENTIONAL
10022753-042	9	0.800	20.32	1.090	27.69	1.015	25.78	2	CONVENTIONAL
10022753-043	10	0.900	22.86	1.190	30.23	1.115	28.32	2	CONVENTIONAL
10022753-044	11	1.000	25.40	1.290	32.77	1.215	30.86	2	CONVENTIONAL
10022753-045	12	1.100	27.94	1.390	35.31	1.315	33.40	2	CONVENTIONAL
10022753-046	13	1.200	30.48	1.490	37.85	1.415	35.94	2	CONVENTIONAL
10022753-047	14	1.300	33.02	1.590	40.39	1.515	38.48	2	CONVENTIONAL
10022753-048	15	1.400	35.56	1.690	42.93	1.615	41.02	2	CONVENTIONAL
10022753-049	16	1.500	38.10	1.790	45.47	1.715	43.56	2	CONVENTIONAL
10022753-050	17	1.600	40.64	1.890	48.01	1.815	46.10	2	CONVENTIONAL
10022753-051	18	1.700	43.18	1.990	50.55	1.915	48.64	2	CONVENTIONAL
10022753-052	19	1.800	45.72	2.090	53.09	2.015	51.18	2	CONVENTIONAL
10022753-053	20	1.900	48.26	2.190	55.63	2.115	53.72	2	CONVENTIONAL
10022753-054	21	2.000	50.80	2.290	58.17	2.215	56.26	2	CONVENTIONAL
10022753-055	22	2.100	53.34	2.390	60.71	2.315	58.80	2	CONVENTIONAL
10022753-056	23	2.200	55.88	2.490	63.25	2.415	61.34	2	CONVENTIONAL
10022753-057	24	2.300	58.42	2.590	65.79	2.515	63.88	2	CONVENTIONAL
10022753-058	25	2.400	60.96	2.690	68.33	2.615	66.42	2	CONVENTIONAL
10022753-059	26	2.500	63.50	2.790	70.87	2.715	68.96	2	CONVENTIONAL
10022753-060	27	2.600	66.04	2.890	73.41	2.815	71.50	2	CONVENTIONAL
10022753-061	28	2.700	68.58	2.990	75.95	2.915	74.04	2	CONVENTIONAL
10022753-062	29	2.800	71.12	3.090	78.49	3.015	76.58	2	CONVENTIONAL
10022753-063	30	2.900	73.66	3.190	81.03	3.115	79.12	2	CONVENTIONAL
10022753-064	31	3.000	76.20	3.290	83.57	3.215	81.66	2	CONVENTIONAL
10022753-065	32	3.100	78.74	3.390	86.11	3.315	84.20	2	CONVENTIONAL
10022753-066	33	3.200	81.28	3.490	88.65	3.415	86.74	2	CONVENTIONAL
10022753-067	34	3.300	83.82	3.590	91.19	3.515	89.28	2	CONVENTIONAL

mat'l. code		surface ISO 1302 ✓	tolerance ISO 406 ISO 1101	projection 	product family CLINCHER
ltr	ecn	nodr	date	tolerances unless otherwise specified	title
F				angles 0°±2'	LATCHING CLINCHER™ RECEPTACLE ASSEMBLY
				linear XXX±.01/0.XX±0.3 XXX±.005/0.XX±0.13 XXX±.0020/0.XXX±0.05	INCH/MM scale 1:1
				dr T. BRUNGARD 4/17/03	dwg no 10022753 sheet 4 of 6 size A3
				engr H. SUNDY 4/17/03	
				chr H. SUNDY 4/17/03	
				appd H. SUNDY 4/17/03	type Product Customer Drawing
sheet index	revision sheet				

FCIconnect.com

Copyright FCI

PRODUCT NO.	NO. OF POSITIONS	DIM. L ENGLISH	DIM. L METRIC	DIM. M ENGLISH	DIM. M METRIC	DIM. C ENGLISH	DIM. C METRIC	PLATING CODE	TERMINATION NOTE 6
10022753-106	6	0.500	12.70	0.790	20.07	0.715	18.16	1	INK
10022753-107	7	0.600	15.24	0.890	22.61	0.815	20.70	1	INK
10022753-108	8	0.700	17.78	0.990	25.15	0.915	23.24	1	INK
10022753-109	9	0.800	20.32	1.090	27.69	1.015	25.78	1	INK
10022753-110	10	0.900	22.86	1.190	30.23	1.115	28.32	1	INK
10022753-111	11	1.000	25.40	1.290	32.77	1.215	30.86	1	INK
10022753-112	12	1.100	27.94	1.390	35.31	1.315	33.40	1	INK
10022753-113	13	1.200	30.48	1.490	37.85	1.415	35.94	1	INK
10022753-114	14	1.300	33.02	1.590	40.39	1.515	38.48	1	INK
10022753-115	15	1.400	35.56	1.690	42.93	1.615	41.02	1	INK
10022753-116	16	1.500	38.10	1.790	45.47	1.715	43.56	1	INK
10022753-117	17	1.600	40.64	1.890	48.01	1.815	46.10	1	INK
10022753-118	18	1.700	43.18	1.990	50.55	1.915	48.64	1	INK
10022753-119	19	1.800	45.72	2.090	53.09	2.015	51.18	1	INK
10022753-120	20	1.900	48.26	2.190	55.63	2.115	53.72	1	INK
10022753-121	21	2.000	50.80	2.290	58.17	2.215	56.26	1	INK
10022753-122	22	2.100	53.34	2.390	60.71	2.315	58.80	1	INK
10022753-123	23	2.200	55.88	2.490	63.25	2.415	61.34	1	INK
10022753-124	24	2.300	58.42	2.590	65.79	2.515	63.88	1	INK
10022753-125	25	2.400	60.96	2.690	68.33	2.615	66.42	1	INK
10022753-126	26	2.500	63.50	2.790	70.87	2.715	68.96	1	INK
10022753-127	27	2.600	66.04	2.890	73.41	2.815	71.50	1	INK
10022753-128	28	2.700	68.58	2.990	75.95	2.915	74.04	1	INK
10022753-129	29	2.800	71.12	3.090	78.49	3.015	76.58	1	INK
10022753-130	30	2.900	73.66	3.190	81.03	3.115	79.12	1	INK
10022753-131	31	3.000	76.20	3.290	83.57	3.215	81.66	1	INK
10022753-132	32	3.100	78.74	3.390	86.11	3.315	84.20	1	INK
10022753-133	33	3.200	81.28	3.490	88.65	3.415	86.74	1	INK
10022753-134	34	3.300	83.82	3.590	91.19	3.515	89.28	1	INK

mat'l. code		surface ISO 1302 ✓	tolerance ISO 406 ISO 1101	projection 	product family CLINCHER
ltr	ecn	nodr	date	title LATCHING CLINCHER™ RECEPTACLE ASSEMBLY	
F				angles 0°±2'	linea XXX±.005/0.XXX±0.13 XXXX±.0020/0.XXX±0.051
				dr T. BRUNGARD 4/17/03	INCH/MM scale 1:1
				engr H. SUNDY 4/17/03	dwg no 10022753
				chr H. SUNDY 4/17/03	sheet 5 of 6 A3
				appd H. SUNDY 4/17/03	type Product Customer Drawing
sheet index	revision sheet				

PRODUCT NO.	NO. OF POSITIONS	DIM. L ENGLISH	DIM. L METRIC	DIM. M ENGLISH	DIM. M METRIC	DIM. C ENGLISH	DIM. C METRIC	PLATING CODE	TERMINATION NOTE 6
10022753-139	6	0.500	12.70	0.790	20.07	0.715	18.16	2	INK
10022753-140	7	0.600	15.24	0.890	22.61	0.815	20.70	2	INK
10022753-141	8	0.700	17.78	0.990	25.15	0.915	23.24	2	INK
10022753-142	9	0.800	20.32	1.090	27.69	1.015	25.78	2	INK
10022753-143	10	0.900	22.86	1.190	30.23	1.115	28.32	2	INK
10022753-144	11	1.000	25.40	1.290	32.77	1.215	30.86	2	INK
10022753-145	12	1.100	27.94	1.390	35.31	1.315	33.40	2	INK
10022753-146	13	1.200	30.48	1.490	37.85	1.415	35.94	2	INK
10022753-147	14	1.300	33.02	1.590	40.39	1.515	38.48	2	INK
10022753-148	15	1.400	35.56	1.690	42.93	1.615	41.02	2	INK
10022753-149	16	1.500	38.10	1.790	45.47	1.715	43.56	2	INK
10022753-150	17	1.600	40.64	1.890	48.01	1.815	46.10	2	INK
10022753-151	18	1.700	43.18	1.990	50.55	1.915	48.64	2	INK
10022753-152	19	1.800	45.72	2.090	53.09	2.015	51.18	2	INK
10022753-153	20	1.900	48.26	2.190	55.63	2.115	53.72	2	INK
10022753-154	21	2.000	50.80	2.290	58.17	2.215	56.26	2	INK
10022753-155	22	2.100	53.34	2.390	60.71	2.315	58.80	2	INK
10022753-156	23	2.200	55.88	2.490	63.25	2.415	61.34	2	INK
10022753-157	24	2.300	58.42	2.590	65.79	2.515	63.88	2	INK
10022753-158	25	2.400	60.96	2.690	68.33	2.615	66.42	2	INK
10022753-159	26	2.500	63.50	2.790	70.87	2.715	68.96	2	INK
10022753-160	27	2.600	66.04	2.890	73.41	2.815	71.50	2	INK
10022753-161	28	2.700	68.58	2.990	75.95	2.915	74.04	2	INK
10022753-162	29	2.800	71.12	3.090	78.49	3.015	76.58	2	INK
10022753-163	30	2.900	73.66	3.190	81.03	3.115	79.12	2	INK
10022753-164	31	3.000	76.20	3.290	83.57	3.215	81.66	2	INK
10022753-165	32	3.100	78.74	3.390	86.11	3.315	84.20	2	INK
10022753-166	33	3.200	81.28	3.490	88.65	3.415	86.74	2	INK
10022753-167	34	3.300	83.82	3.590	91.19	3.515	89.28	2	INK

mat'l. code		surface ISO 1302 ✓	tolerance ISO 406 ISO 1101	projection 	product family CLINCHER
ltr	ecn	no	dr	date	title
F					LATCHING CLINCHER™ RECEPTACLE ASSEMBLY
angles 0°±2'		linear XXX±.01/XXX±0.3 XXX±.005/XXX±0.13 XXX±.0020/XXX±0.051	tolerances unless otherwise specified		INCH/MM scale 1:1
dr	T. BRUNGARD	4/17/03	dwg no 10022753 sheet 6 of 6 size A3		
engr	H. SUNDY	4/17/03	type Product Customer Drawing		
chr	H. SUNDY	4/17/03			
appd	H. SUNDY	4/17/03			
sheet index	revision sheet				

FCIconnect.com

Copyright FCI