

⚠ Discontinued as of August 31, 2012

Panasonic
ideas for life

**2.5 GHz
MICROWAVE RELAY
WITH 60 W
CARRYING POWER**

RX-P RELAYS (ARXP)



⚠ Product to be discontinued.

FEATURES

1. 60 W contact carrying power realized

- Three times the contact carrying power achieved compared to previous 20 W RX relay.
- Nominal switching capacity (when switching) also improved to 40W.

2. Excellent high frequency characteristics

- High frequency characteristics (to 2.5GHz, Impedance: 50Ω, Initial)

Insertion loss (Max.)	0.2dB
Isolation (Min.)	60dB
V. S. W. R. (Max.) (Return loss) (Min.)	1.2 or less (20.8dB)
Contact carrying power	Max. 60W (at 20°C 68°F, V.S.W.R. ≤ 1.2, Average)

3. Small size

L: 20.5, W: 12.4, H: 9.4 mm
L: .807, W: .488, H: .370 inch

4. High sensitivity

Nominal operating power: 200mW
(Single side stable type and 1 coil latching type)

TYPICAL APPLICATIONS

1. Base stations (mobile phones, terrestrial digital, etc.)

Used for redundant circuit construction in transmitter section.

2. Other applications

High-frequency amp switching in wireless devices, etc.

ORDERING INFORMATION

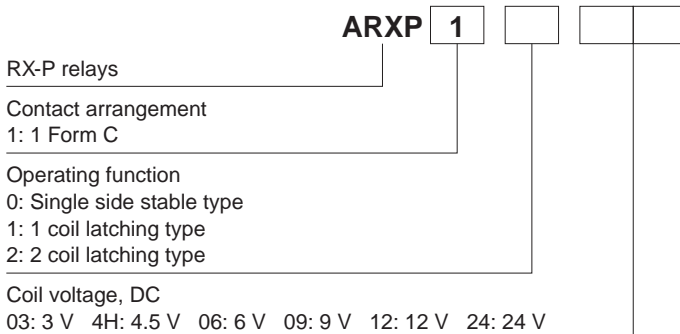

TYPES

Nominal coil voltage	Part No.		
	Single side stable type	1 coil latching type	2 coil latching type
3 V DC	ARXP1003	ARXP1103	ARXP1203
4.5 V DC	ARXP104H	ARXP114H	ARXP124H
6 V DC	ARXP1006	ARXP1106	ARXP1206
9 V DC	ARXP1009	ARXP1109	ARXP1209
12 V DC	ARXP1012	ARXP1112	ARXP1212
24 V DC	ARXP1024	ARXP1124	ARXP1224

Standard packing: 50 pcs. in an inner package; 500 pcs. in an outer package

RATING**1. Coil data**

1) Single side stable type

Nominal coil voltage	Pick-up voltage (at 20°C 68°F)	Drop-out voltage (at 20°C 68°F)	Nominal operating current [±10%] (at 20°C 68°F)	Coil resistance [±10%] (at 20°C 68°F)	Nominal operating power	Max. allowable voltage
3 V DC	75%V or less of nominal voltage (Initial)	10%V or more of nominal voltage (Initial)	66.7 mA	45 Ω	200 mW	110%V or less of nominal voltage (at 60°C 140°F) 150%V or less of nominal voltage (at 20°C 68°F)
4.5 V DC			44.4 mA	101 Ω		
6 V DC			33.3 mA	180 Ω		
9 V DC			22.2 mA	405 Ω		
12 V DC			16.7 mA	720 Ω		
24 V DC			8.3 mA	2,880 Ω		

2) 1 coil latching type

Nominal coil voltage	Set voltage (at 20°C 68°F)	Reset voltage (at 20°C 68°F)	Nominal operating current [±10%] (at 20°C 68°F)	Coil resistance [±10%] (at 20°C 68°F)	Nominal operating power	Max. allowable voltage
3 V DC	75%V or less of nominal voltage (Initial)	75%V or less of nominal voltage (Initial)	66.7 mA	45 Ω	200 mW	110%V or less of nominal voltage (at 60°C 140°F) 150%V or less of nominal voltage (at 20°C 68°F)
4.5 V DC			44.4 mA	101 Ω		
6 V DC			33.3 mA	180 Ω		
9 V DC			22.2 mA	405 Ω		
12 V DC			16.7 mA	720 Ω		
24 V DC			8.3 mA	2,880 Ω		

3) 2 coil latching type

Nominal coil voltage	Set voltage (at 20°C 68°F)	Reset voltage (at 20°C 68°F)	Nominal operating current [±10%] (at 20°C 68°F)	Coil resistance [±10%] (at 20°C 68°F)	Nominal operating power	Max. allowable voltage
3 V DC	75%V or less of nominal voltage (Initial)	75%V or less of nominal voltage (Initial)	133.3 mA	22.5Ω	400 mW	110%V or less of nominal voltage (at 60°C 140°F) 150%V or less of nominal voltage (at 20°C 68°F)
4.5 V DC			88.9 mA	50.6Ω		
6 V DC			66.7 mA	90 Ω		
9 V DC			44.4 mA	202.5Ω		
12 V DC			33.3 mA	360 Ω		
24 V DC			16.7 mA	1,440 Ω		

2. Specifications

Item		Specifications	
Contact	Arrangement	1 Form C	
	Contact material	Fixed: Au plating Movable: Au clad	
	Contact resistance (Initial)	Max. 100 mΩ (By voltage drop 10 V AC 10mA)	
Rating	Nominal switching capacity	40W (at 2.5GHz, Impedance: 50Ω, V.S.W.R.: Max. 1.2)	
	Contact carrying power	Max. 60W (at 2.5GHz, Impedance: 50Ω, V.S.W.R.: Max. 1.2)	
	Max. switching voltage	30 V DC	
	Max. switching current	0.5 A DC	
	Nominal operating power	Single side stable type	200mW
		1 coil latching type	200mW
2 coil latching type		400mW	
High frequency characteristics, Impedance: 50Ω (to 2.5GHz) (Initial)	V.S.W.R. (Return loss)	Max. 1.2 (Min. 20.8dB)	
	Insertion loss	Max. 0.2dB	
	Isolation	Min. 60dB	
	Contact carrying power	Max. 60W (at 20°C 68°F, V.S.W.R. ≤ 1.2, Average)	
Electrical characteristics	Insulation resistance (Initial)	Min. 100MΩ (at 500V DC, Measurement at same location as "Breakdown voltage" section.)	
	Breakdown voltage (Initial)	Between open contacts	500 Vrms for 1 min. (Detection current: 10mA)
		Between contact and coil	1,000 Vrms for 1 min. (Detection current: 10mA)
		Between contact and earth terminal	500 Vrms for 1 min. (Detection current: 10mA)
	Temperature rise (at 20°C 68°F)	Max. 60°C 140°F (By resistive method, nominal voltage applied to the coil, contact carrying power: 20W at 2.5GHz, 50Ω, V.S.W.R. ≤ 1.2)	
	Operate time (at nominal voltage, at 20°C 68°F)	Single side stable type	Max. 10 ms (Approx. 6 ms) (Nominal voltage applied to the coil, excluding contact bounce time)
		1 coil latching type	Max. 10 ms (Approx. 5 ms)
		2 coil latching type	(Nominal voltage applied to the coil, excluding contact bounce time)
	Release time (at nominal voltage, at 20°C 68°F)	Single side stable type*1	Max. 6 ms (Approx. 3 ms) (Nominal voltage applied to the coil, excluding contact bounce time) (without diode)
		1 coil latching type	Max. 10 ms (Approx. 5 ms)
2 coil latching type		(Nominal voltage applied to the coil, excluding contact bounce time)	
Mechanical characteristics	Shock resistance	Functional	Min. 200 m/s ² (Half-wave pulse of sine wave: 11 ms, detection time: 10μs)
		Destructive	Min. 1,000 m/s ² (Half-wave pulse of sine wave: 6 ms)
	Vibration resistance	Functional	10 to 55 Hz at double amplitude of 3 mm (Detection time: 10μs)
		Destructive	10 to 55 Hz at double amplitude of 5 mm
Expected life	Mechanical life	Min. 10 ⁴ (at 180 cpm)	
	Electrical life	Min. 10 ⁴ (40W, at 2.5GHz, Impedance: 50Ω, V.S.W.R: Max. 1.2) (at 20 cpm)	
Conditions	Conditions for operation, transport and storage*2	Ambient temperature: -40 to 70°C -40°F to 158°F Humidity: 5 to 85% R.H. (Not freezing and condensing at low temperature)	
Unit weight		Approx. 5 g .18 oz	

Notes:*

*1 Release time will lengthen if a diode, etc., is connected in parallel to the coil. Be sure to verify operation under actual conditions.

*2 The upper operation ambient temperature limit is the maximum temperature that can satisfy the coil temperature rise value. Refer to "6. Usage, Storage and Transport Conditions" in AMBIENT ENVIRONMENT section in Relay Technical Information.

REFERENCE DATA

1. High frequency characteristics

Sample: ARXP1012; Measuring method: Measured with Agilent Technologies network analyzer (E8363B). *For details see No. 8 under "NOTES".

• V.S.W.R. characteristics

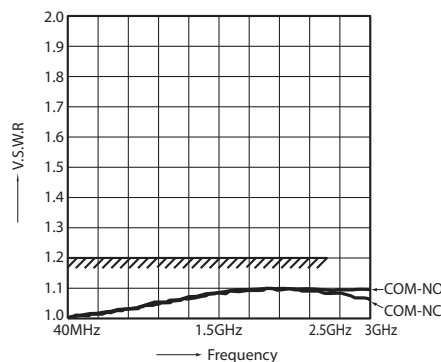

• Insertion loss characteristics (without D.U.T. board's loss)

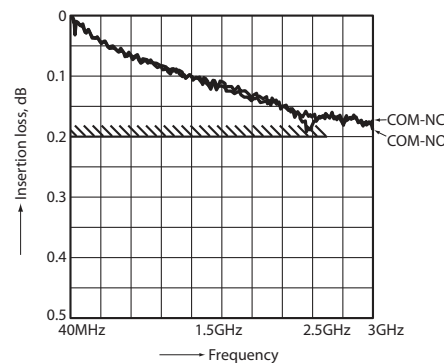

• Isolation characteristics

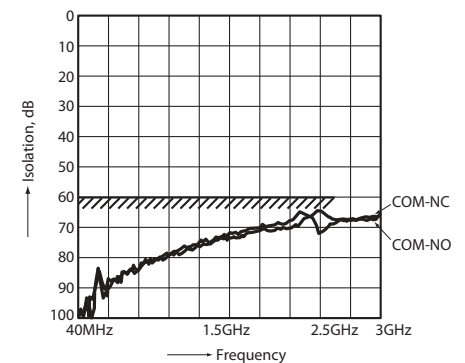

DIMENSIONS(mm inch)

Download [CAD Data](#) from our Web site.

CAD Data



External dimensions

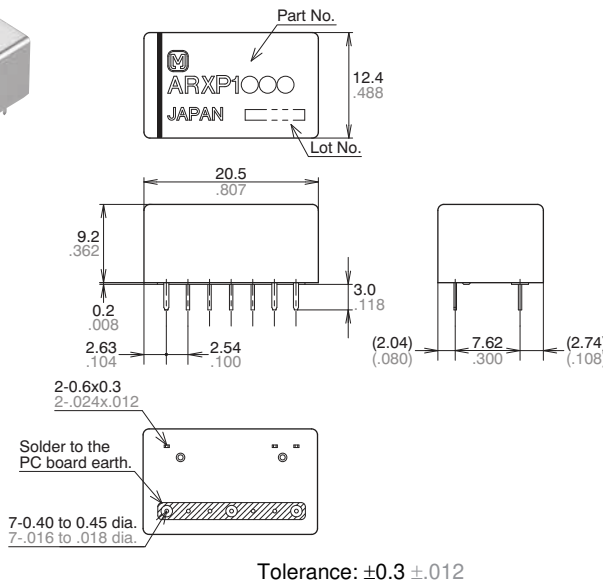

PC board pattern (Bottom view)

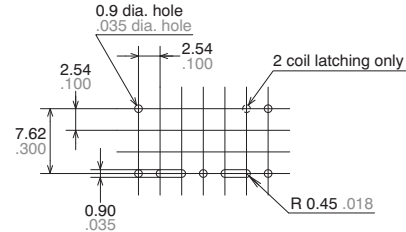

Tolerance: $\pm 0.1 \pm .004$

Schematic (Bottom view)

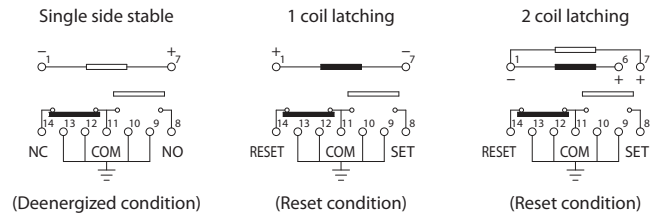

NOTES

1. Coil operating power

Pure DC current should be applied to the coil. The wave form should be rectangular. If it includes ripple, the ripple factor should be less than 5%.

However, check it with the actual circuit since the characteristics may be slightly different.

2. Coil connection

When connecting coils, refer to the wiring diagram to prevent mis-operation or malfunction.

To ensure accurate operation, the voltage on both sides of the coil should be $\pm 5\%$ (at 20°C 68°F) of the nominal coil voltage.

Also, please note that the pick-up and drop-out voltages (set and reset voltages) will change depending on operation temperature and conditions of use.

Keep the coil allowable voltage ripple ratio to no more than 5%.

3. External magnetic field

Since RX-P relays are highly sensitive polarized relays, their characteristics will be affected by a strong external magnetic field. Avoid using the relay under that condition.

4. Cleaning

For automatic cleaning, the boiling method is recommended. Avoid ultrasonic cleaning which subjects the relays to high frequency vibrations, which may cause the contacts to stick.

It is recommended that alcoholic solvents be used.

5. Soldering

1) Please meet the following conditions if this relay is to be automatically soldered.

- (1) Preheating: Max. 120°C 248°F (terminal solder surface) for max. 120 seconds
- (2) Soldering: Max. $260 \pm 5^\circ\text{C}$ $500 \pm 41^\circ\text{F}$ for max. 6 seconds

2) Please meet the following conditions if this relay is to be soldered by hand.

- (1) 260°C 500°F for max. 10 seconds
- (2) 350°C 662°F for max. 3 seconds

*In addition, when soldering the case to the PC board, the plating may swell depending on the soldering conditions.

6. Conditions for operation, transport and storage conditions

1) Ambient temperature, humidity, and atmospheric pressure during usage, transport, and storage of the relay:

- (1) Temperature: -40 to $+70^\circ\text{C}$ -40 to $+158^\circ\text{F}$ (However, when 60 to 70°C 140 to 158°F , the pulse time is 1 second maximum and ON time is 10% maximum.)

(2) Humidity: 5 to 85% RH

(Avoid freezing and condensation.)

The humidity range varies with the temperature. Use within the range indicated in the graph below.

(3) Atmospheric pressure: 86 to 106 kPa
Temperature and humidity range for usage, transport, and storage:

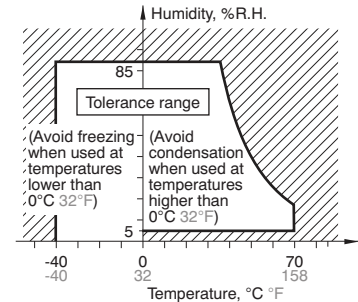

2) Condensation

Condensation forms when there is a sudden change in temperature under high temperature and high humidity conditions. Condensation will cause deterioration of the relay insulation.

3) Freezing

Condensation or other moisture may freeze on the relay when the temperature is lower than 0°C 32°F . This causes problems such as sticking of movable parts or operational time lags.

4) Low temperature, low humidity environments

The plastic becomes brittle if the relay is exposed to a low temperature, low humidity environment for long periods of time.

7. Latching relay

1) To ensure accurate operation of the latching type amidst surrounding temperature changes and other factors that might affect the set and reset pulse times, we recommend a coil impress set and reset pulse width of at least 30 ms at the rated operation voltage.

2) The latching type relay is shipped in the reset position. But jolts during transport or impacts during installation can change the reset position. It is, therefore, advisable to build a circuit in which the relay can be initialized (set and reset) just after turning on the power.

8. Measuring method

50Ω type

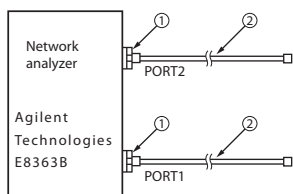

Connect connectors 1 and 2 respectively to PORT 1 and PORT 2. Perform calibration using the 3.5 mm calibration kit (HP85052B).

No.	Product name	Contents
1	Agilent 85130-60011	Adapter 2.4mm-3.5mm female .095inch-.138inch female
2	SUHNER SUCOFLEX104	Cable 3.5mm-3.5mm male .138inch-.138inch male

After calibration, connect the D.U.T. board and measure. However, connectors other than those for measurement should be connected with a 50Ω termination resistor.

PC board

Dimensions (mm inch)

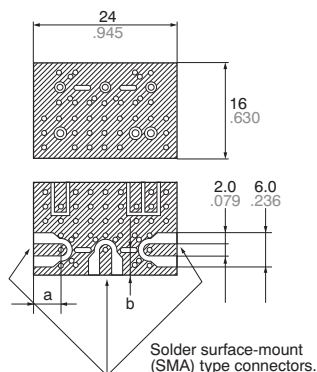

PC board for correction
Dimensions (mm inch)

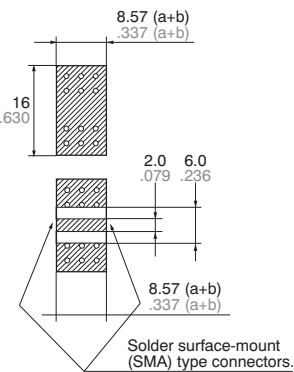

Material: Glass PTFE double-sided through hole PC board R-4737 (Matsushita Electric Works)
Board thickness: t = 0.8 mm .031 inch
Copper plating: 18 μm
Connector (SMA type receptacle)
Product name: 01K1808-00 (Waka Manufacturing Co., Ltd.)
Value has compensation PC board subtracted only for insertion loss. (Eliminate loss of connector and PC board.)

9. Others

1) The switching lifetime is defined under the standard test condition specified in the JIS C 5442 standard (temperature 15 to 35°C 59 to 95°F, humidity 25 to 85%R.H.). Check this with the real device as it is affected by coil driving circuit, load type, activation frequency, activation phase, ambient conditions and other factors.

Also, be especially careful of loads such as those listed below.

- When used for AC load-operating and the operating phase is synchronous, rocking and fusing can easily occur due to contact shifting.
- When high-frequency opening and closing of the relay is performed with a load that causes arcs at the contacts, nitrogen and oxygen in the air is fused by the arc energy and HNO₃ is formed. This can corrode metal materials. Three countermeasures for these are listed here.

- (1) Incorporate an arc-extinguishing circuit.
- (2) Lower the operating frequency
- (3) Lower the ambient humidity

2) Use the relay within specifications such as coil rating, contact rating and on/off service life. If used beyond limits, the relay may overheat, generate smoke or catch fire.

3) Be careful not to drop the relay. If accidentally dropped, carefully check its appearance and characteristics before use.

4) Be careful to wire the relay correctly. Otherwise, malfunction, overheat, fire or other trouble may occur.

5) If a relay stays on in a circuit for many months or years at a time without being activated, circuit design should be reviewed so that the relay can remain non-excited. A coil that receives current all the time heats, which degrades insulation earlier than expected. A latching type relay is recommended for such circuits.

6) If silicone materials (e.g., silicone rubbers, silicone oils, silicone coating agents, silicone sealers) are used in the vicinity of the relay, the gas emitted from the silicone may adhere to the contacts of the relay during opening and closing and lead to improper contact. If this is the case, use a material other than silicone.

For Cautions for Use, see [Relay Technical Information](#).