

# DCNLR SERIES

## 60V DC MAX CONTACTOR RELAY



DCNLR100NB

DCNLR200NB48

### Description

Ideal for safely disconnecting DC energy sources in 48V applications that require continuous run time, the DCNLR Series 60V DC Max Contactor Relay features an IP67 rating for protection against water and dust common in harsh environmental conditions. The remote-operated contactor has a space-saving design and can be easily installed in any orientation, making it simple to incorporate into battery electric vehicles (BEV), hybrid electric vehicles (HEV), material handling equipment, telecom power supplies, battery energy storage systems, construction machinery, heavy-duty trucks, buses, and more. Configurations of the DCNLR Series remote DC contactor come with a continuous current rating of either 100A or 200A. The 200A DCNLR Series contactor models feature a 12V, 24V, 48V, or 60V coil, while the 100A models are available with a 12V, 24V, or 48V coil.

### Web Resources

Download 2D print, installation guide and technical resources at: [littelfuse.com/DCNLR](http://littelfuse.com/DCNLR)

### Electrical Diagram

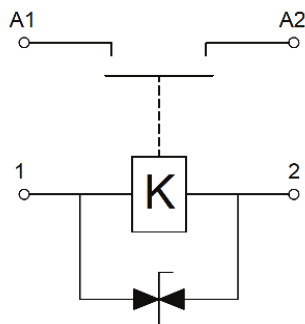

### Specifications

<b>Max Voltage Rating (V DC):</b>	60
<b>Current Rating Continuous (A):</b>	100, 200
<b>Coil Voltage Rating (V DC):</b>	12, 24, 48, 60
<b>Ingress Protection:</b>	IP67
<b>Operating Temperature (°C):</b>	-40 to +85

### Features and Benefits

- Available with a continuous current rating of 100A or 200A
- Thermoplastic housing and an IP67 rating enable use in harsh automotive environments and heavy equipment applications
- Remote-operated, space-saving design can be easily mounted in any orientation
- Main contacts are rated for 48V (typical) and 60V (max)
- Common coil voltage options of 12V, 24V, 48V, and 60V
- Non-polarized copper alloy main contacts
- Integral coil suppression

### Applications

- Battery Electric Vehicles
- Hybrid Electric Vehicles
- Material Handling Equipment
- Telecom Power Supplies
- Battery Energy Storage Systems
- Construction Machinery
- Heavy-Duty Trucks
- Buses

# DCNLR SERIES

## 60V DC MAX CONTACTOR RELAY

### Ordering Information

PART NUMBER	CONTINUOUS CURRENT (A)	VOLTAGE RATING		MOUNTING	COIL VOLTAGE (V DC)	COIL TYPE	AUX CONTACT	POLARIZED
		SYSTEM NOMINAL (V DC)	MAX VOLTAGE (V DC)					
DCNLR100NB12	100	48	60	BOTTOM	12	Single	No	No
DCNLR100NB24	100	48	60	BOTTOM	24	Single	No	No
DCNLR100NB48	100	48	60	BOTTOM	48	Single	No	No
DCNLR200NB12	200	48	60	BOTTOM	12	Single	No	No
DCNLR200NB24	200	48	60	BOTTOM	24	Single	No	No
DCNLR200NB48	200	48	60	BOTTOM	48	Single	No	No
DCNLR200NB60	200	48	60	BOTTOM	60	Single	No	No

### Performance Data

MAIN CONTACT		
Contact Arrangement	SPST NO	
Rated Operating Voltage	48V DC	
Max Short Circuit Current	DCNLR100	400A @ 48V DC
	DCNLR200	800A @ 48V DC
Dielectric Withstand Voltage	DCNLR100	2000V AC
	DCNLR200	2200V AC
Insulation Resistance	≥ 100MΩ @ 500V DC	
Max Voltage Drop	DCNLR100	≤ 50mV @ 100A
	DCNLR200	≤ 80mV @ 200A

COIL DATA					
Voltage Rating (V DC)	12	24	48	60	
Pickup Voltage @ 25°C (V DC MAX)	9	18	36	45	
Dropout Voltage @ 25°C (V DC MIN)	1	2	4	5	
Hold Current (A)	DCNLR100	0.48	0.24	0.12	-
	DCNLR200	0.78	0.39	0.2	0.16
Coil Watts @ 25°C (W)	DCNLR100	8			
	DCNLR200	9.5			

LIFE	
Electrical Life	30,000
Mechanical Life	200,000

OPERATE / RELEASE TIME	
Close (ms)	25
Release (ms)	12

ENVIRONMENTAL DATA		
Shock	Shock, 11ms ½ Sine, Peak, Operating 20G	
Vibration	Vibration, Sine, 80-2000Hz., Peak 20G	
Operating Ambient Temperature	-40°C~+85°C	
Weight (g)	DCNLR100	193
	DCNLR200	350

Note: Estimated Make Break Charts and Time Current Curves Coming Soon

# DCNLR SERIES

## 60V DC MAX CONTACTOR RELAY

### Part Number System

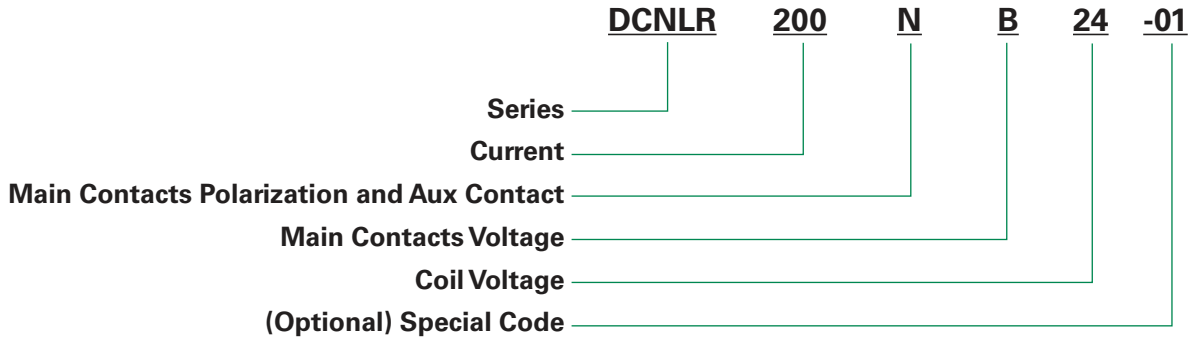

MAIN CONTACTS POLARIZATION AND AUX CONTACT		
	POLARIZED?	INCLUDE AUX CONTACT?
N:	No	No

MAIN CONTACTS VOLTAGE RATING		
B:	48	V DC

COIL VOLTAGE		
12:	12	V DC
24:	24	V DC
48:	48	V DC
60:	60	V DC

# DCNLR SERIES

## 60V DC MAX CONTACTOR RELAY

### Application Notes & Definitions

- Be sure to use a washer to prevent screws from loosening. Tighten the screw so that the torque is in the range specified below. Exceeding the maximum torque can lead to product rupture.
  - Contact torque (M8): 80 - 100 lb.in (8.8 - 11 N.m)
  - Mounting torque: 15 - 30 lb.in (1.7 - 3.3 N.m)
- Please refer to the drawing for connection polarity.
- Do not use dropped products.
- Avoid installing the product in a strong magnetic field (Close to the transformer or magnet), or near an object with heat radiation.
- Electrical life
 

Please use under load capability and life cycle so as not to cause a function failure. (Please also treat the contactor as a product with specified life and replace it when necessary). It is possible to make parts burn around the contactor once operating failure happens. So it is necessary to take layout into account to make sure power shall be cut off within 1 second.
- Lifetime of internal gas diffusion
 

The contactor is sealed and filled with gas, lifetime of gas diffusion is determined by temperature in contact chamber (Ambient temperature + Temperature rising by contact energizing). Therefore environment temperature should be from -40 to +85°C.
- Do not let particle and oil stain on the main terminal with which the load shall make a reliable contact or it will cause a lot of heat.

PRODUCT SERIES	PRODUCT MODEL	CONTACT TERMINAL		COIL TERMINAL		MOUNTING
		HOLE OR BOLT	REFERENCE TORQUE	HOLE/BOLT/WIRE/TERMINAL	REFERENCE TORQUE	REFERENCE TORQUE
DCNLR100NB	DCNLR100NB12 DCNLR100NB24 DCNLR100NB48	Bolt : M6	3.5~4.5N.m	Terminal	-	3.5~4.5N.m
DCNLR200NB	DCNLR200NB12 DCNLR200NB24 DCNLR200NB48 DCNLR200NB60	Bolt : M8	8~12N.m	Bolt: M4	1.0~1.6N.m	2.0~2.8N.m