

LOC		DIST		REVISIONS			
DF	XO	REV	DATE	DESCRIPTION	DATE	DWN	APVD
		0	4-04	RELEASED		CT	RG

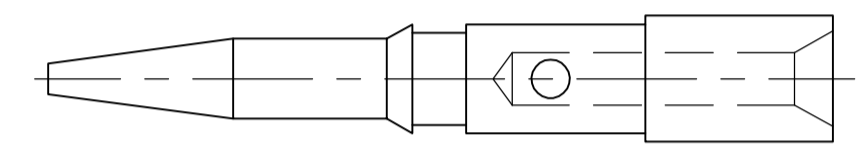

1. CONTACT AND FERRULE PACKAGED UNASSEMBLED.
2. USE PRO CRIMPER 354940-1 WITH DIESET 58436-1.
3. FOR USE WITH CABLE: BELDON 9266 AND FM-59.
4. HEX CRIMP HEIGHTS:
 FERRULE: .255 [6.48]
 CONTACT: .068 [1.73]
5. CONNECTOR INDIVIDULLY PACKAGED.

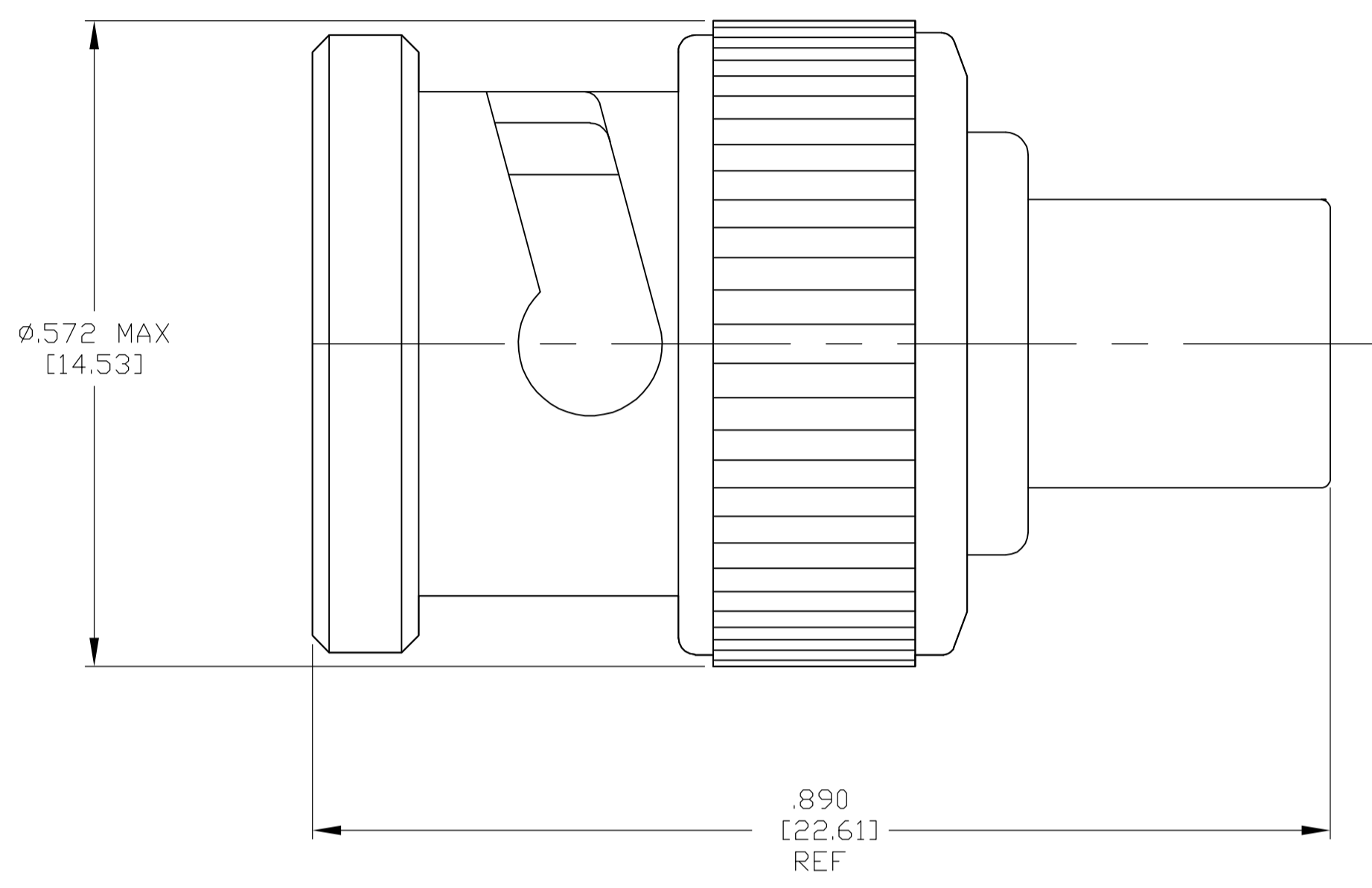
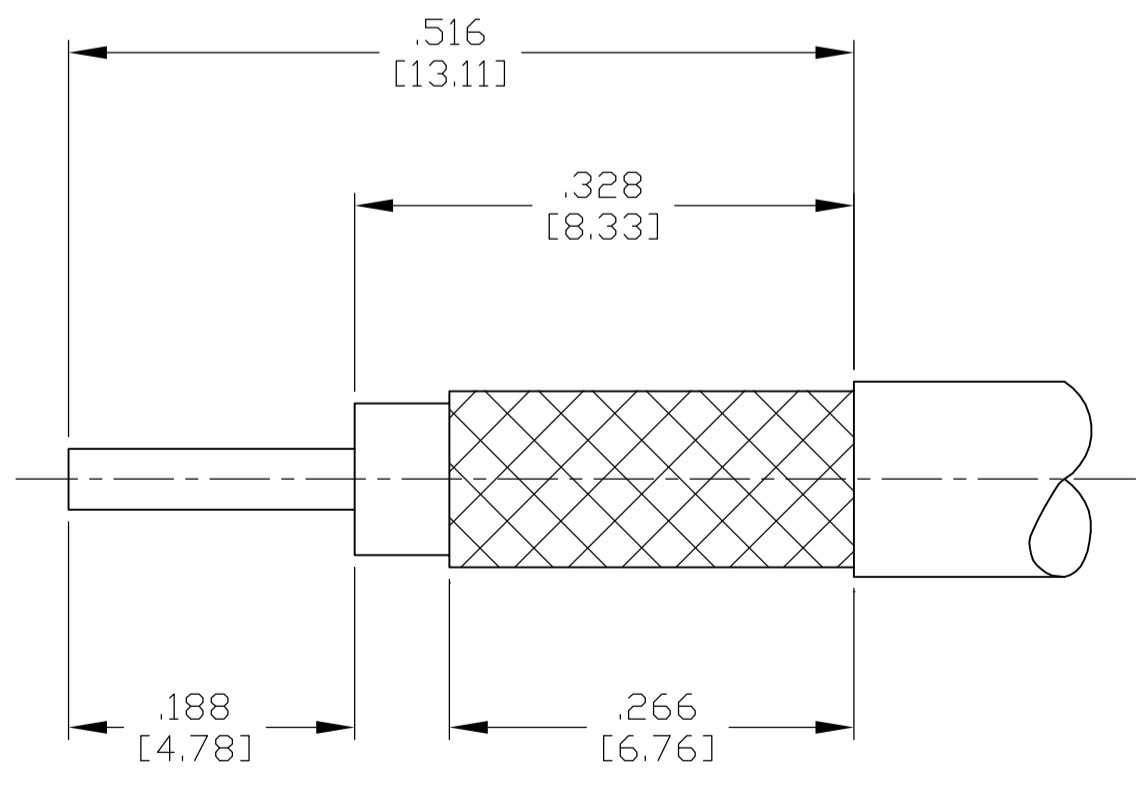

RECOMMENDED STRIP LENGTH

1757099-1
 PART NUMBER

THIS DRAWING IS A CONTROLLED DOCUMENT.		DWG C.C.THOMAS	23APR04	tyco Electronics	Tyco Electronics Corporation Harrisburg, Pa 17105-3608	
DIMENSIONS: INCHES		CHK R.GROSS	4-23-04		NAME R.GROSS	PLUG ASSY,BNC
TOLERANCES UNLESS OTHERWISE SPECIFIED:		APVD R.GROSS		APPLICATION SPEC I.S. 9021		RESTRICTED TO
0 PLC ± -		PRODUCT SPEC		SIZE A1		SCALE 8:1 SHEET 1 OF 1 REV 0
1 PLC ± -		NAME		CAGE CODE 00779		
2 PLC ± -		DRAWING NO		C=1757099		
3 PLC ± .016 [0.41]		WEIGHT		CUSTOMER DRAWING		
4 PLC ± -		MATERIAL				
ANGLES ± -		FINISH				