

80C32MODULE

80C32 Module

80C32 Module General Description

The Maxim 80C32 microcontroller (μC) module is intended for use with this and other Maxim evaluation kits (EV kits). It contains the 80C32 μC , RS-232 interface, 8kbytes of EPROM, 32kbytes of static RAM, and address decoding logic. A 40-pin connector mates with a connector found on Maxim EV kits designed to interface with the 80C32 module.

80C32 Module Component List

DESIGNATION	QTY	DESCRIPTION
C1, C2	2	15pF ceramic capacitors
C4, C5, C6, C7, C8, C9, C10, C11, C12	9	0.1 μF , 50V ceramic capacitors
C3, C13, C14	3	22 μF , 16V radial electrolytic capacitors
D1	1	1N4001 diode
J1	1	40-pin right-angle male connector
J2	1	DB9 right-angle socket
R1	1	620 Ω resistor
RS1	1	10k Ω 10-pin, 9-resistor SIP
SW1	1	Power switch
SW2	1	Reset switch
IC1	1	80C32
IC2	1	MAX233CPP
IC3	1	27C64
IC4	1	74HCT573
IC5	1	74HCT139
IC6	1	74HCT08
IC7	1	74HCT245
IC8	1	62256
IC9	1	78M05
IC10	1	MAX707CPA
Y1	1	11.059MHz crystal
None	1	2-pin power connector
None	1	28-pin 600-mil socket for IC3 (the EPROM)
None	4	Rubber feet
None	1	3.00" x 5.50" PC board

The module is connected to an IBM-compatible personal computer over a serial communications port. Software provided with each EV kit runs on the computer and controls the unit consisting of the 80C32 module and EV kit. The program uses a routine stored in the 27C64 EPROM to download special 80C32 code for each kit. The downloaded code controls the EV kit and, together with the program running on the personal computer, displays the output data.

The board operates from a single 8V to 22V supply. Both the pre-regulated and regulated +5V levels are available to the EV kit through the 40-pin connector.

80C32 Module Power Supply

The Maxim 80C32 module requires an input of 8V to 22V for normal operation. An on-board 78M05 power regulator supplies the 5V required for the logic on the module, and any 5V requirements for the EV kit attached to the 40-pin connector. The pre-regulated voltage is also available on the data connector. The source must be capable of supplying 100mA for the module and meeting the load requirements of the EV kit.

Microprocessor Supervisor

A MAX707 on the module monitors the 5V logic supply, generates the power-on reset, and produces a reset pulse whenever the reset button is pressed. A watchdog function was not included because they frequently interfere while debugging programs, and debugging is a prime function of this board.

80C32 Microcontroller

The 80C32 is a member of the popular Intel 8051 family of μC s. It is a low-power CMOS version that requires external ROM for program storage, 256 bytes of internal RAM, and four 8-bit I/O ports. Three of the ports are required by the system for serial communications and memory control. The fourth port (P1) is available through the data connector.

The 80C32 communicates with the PC over a serial RS-232 link. A MAX233 acts as a level shifter between the $\pm 15\text{V}$ RS-232 signals and the TTL levels of the 80C32.

MAX186 Evaluation System/Evaluation Kit

The MAX233 also generates the output voltages necessary to drive RS-232 lines.

Port 0 (pins 32-39) of the 80C32 multiplexes the lower eight bits of memory address and the eight bits of read/write data. The lower eight bits of address data are latched during each I/O cycle by the 74HCT573 octal latch. The latch is controlled by the address latch enable (ALE) signal of the 80C32. Port 2 (pins 21-28) of the 80C32 supplies the upper eight bits of address information.

The port 3 pins (10-17) provide several unrelated functions. Pins 10 and 11 are used as the receive data (RxD) and transmit data (TxD) pins of the RS-232 link. Pins 16 and 17 act as the write (\overline{WR}) and read (\overline{RD}) control signals for the data I/O cycles. Four other pins are configured as interrupt and timer controls, but are not used on this board.

Memory

The board has a 27C64 EPROM containing code for initializing the 80C32 and downloading additional program code to the 62256 RAM. After a reset, the EPROM resident code initializes the 80C32, determines the address range of the RAM, sets the RS-232 baud rate to 1200, and waits for communications from the PC. Receiving any character will prompt the program to send an initial banner that includes the program name, revision level, and boundaries of the on-board RAM.

The 62256 CMOS (32kbyte) static RAM is used to hold program code for the various Maxim EV kits that use the 80C32 module as the controller. Programs are transferred from disk to the RAM using software running on a personal computer, such as MAXLOAD or other programs provided with Maxim EV kits. Programs written to execute from this RAM start at 4000 (HEX) and are typically less than 4kbytes long. The remaining RAM is available for data storage.

Address Ranges

Logic on the module board generates various enable signals for different address ranges. The ROM and RAM enable signals are fed directly to the respective chips. Several additional signals (CS0-CS3) are available on the data connector to be used by Maxim EV kits. Table 1 outlines the address range for each of the elements found on the 80C32 module.

Table 1. Address Ranges in Hexadecimal

ADDRESS RANGE (HEX)	ENABLE SIGNAL
0000 → 3FFF	ROM
4000 → BFFF	RAM
C000 → CFFF	CS0
D000 → DFFF	CS1
E000 → EFFF	CS2
F000 → FFFF	CS3

Data I/O Connector

A 40-pin connector mounted on the edge of the printed circuit board provides connection between the μ C module and other Maxim EV kits. Both power and digital signals are transferred via the connector. To join the module board with an EV kit, carefully align and insert the pins on the connector with the mating 40-pin female connector of the kit. The pin functions are listed in Table 2.

Table 2. I/O Connector Pin Functions

PIN	FUNCTION	DESCRIPTION
1-4	Ground	
5, 6	Pre-regulator input	
7, 8	Regulated +5V	
9	\overline{RD}	Read strobe
10	\overline{WR}	Write strobe
11	$\overline{CS0}$	Address C000-CFFF
12	$\overline{CS1}$	Address D000-DFFF
13	$\overline{CS2}$	Address E000-EFFF
14	$\overline{CS3}$	Address F000-FFFF
15-18	ADDR0-ADDR3	Lowest 4 bits of address
19-26	DB0-DB7	8-bit data bus
27-34	P1.0-P1.7	8 bits of port 1
35-40	Reserved	

MAX186 Evaluation System/Evaluation Kit

Software Architecture

Software for EV kits using the Maxim 80C32 module is divided into three elements: the interface program running on an IBM-compatible PC, a module program located in EPROM, and a program supplied on disk that is transferred to the RAM located on the module.

EPROM Resident Program

The EPROM resident program initializes the 80C32, establishes communications over the RS-232 link, verifies the static RAM, and downloads other programs. Its operation starts on power-up and whenever the reset button is pressed. After reset, the program waits indefinitely to receive a character over the RS-232 port. When the first character is received, a logon banner identifying the module and firmware revision is transmitted.

Immediately following transmission of the logon banner, the program runs a checker routine for the on-board 256kbit static RAM. The RAM is filled with several patterns and then read to verify that each pattern has been retained. A pass or fail indication is displayed on the personal computer after each pass. EV kit software requires proper operation of the RAM. Do not attempt to use the board if any of the RAM checks fail.

Two other programs for the EV kits are provided on a floppy disk shipped with each kit. One program acts as the user interface and transmits commands to the 80C32 module. The other is an 80C32 application program that executes from the RAM located on the module. The procedure for loading the programs varies with each kit, so follow the instructions provided.

MAX186 Evaluation System/Evaluation Kit

Evaluates: MAX186

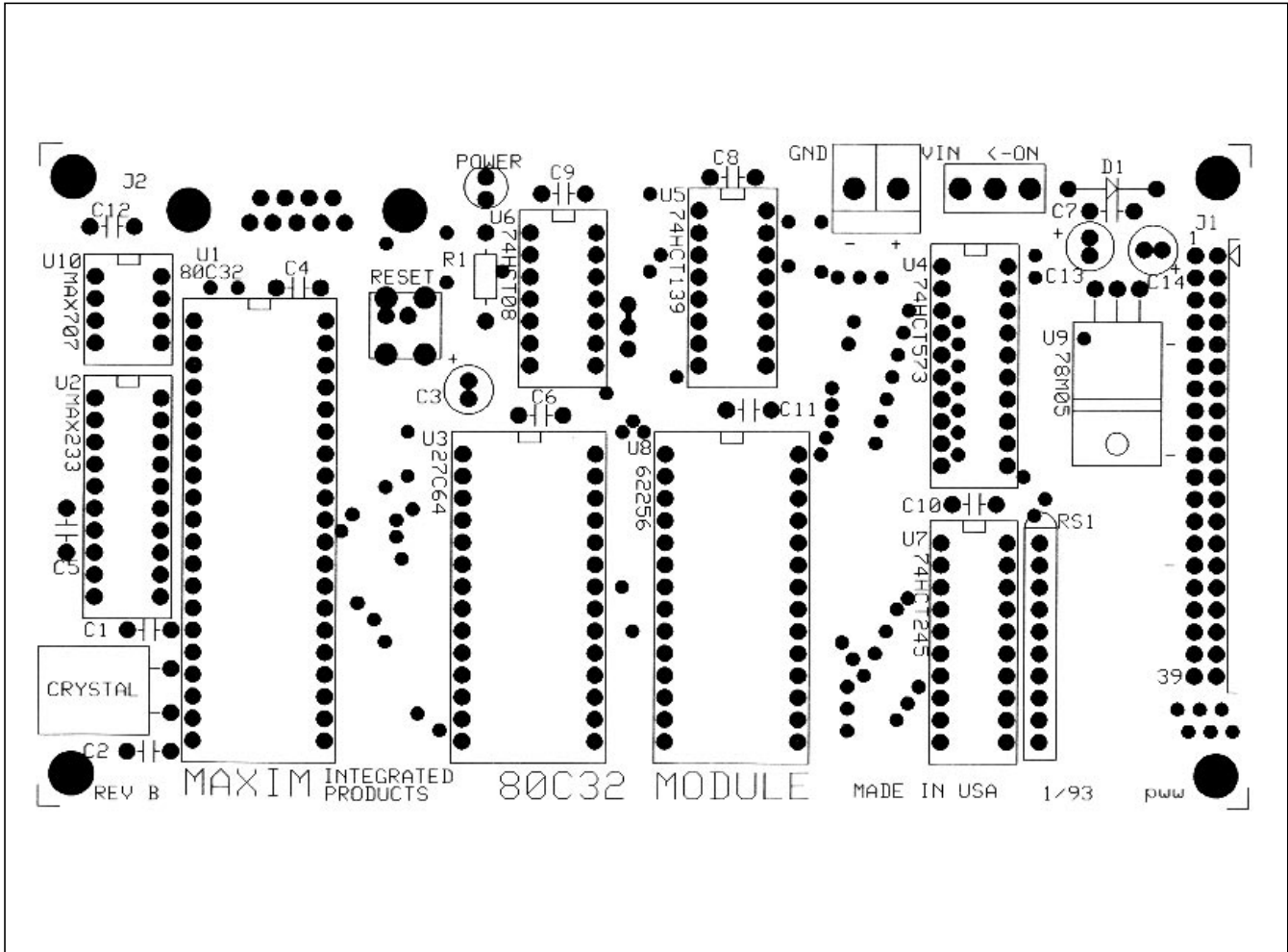

Figure 5. 80C32 Module Component Placement Guide (x2)

MAX186 Evaluation System/Evaluation Kit

Evaluates: MAX186

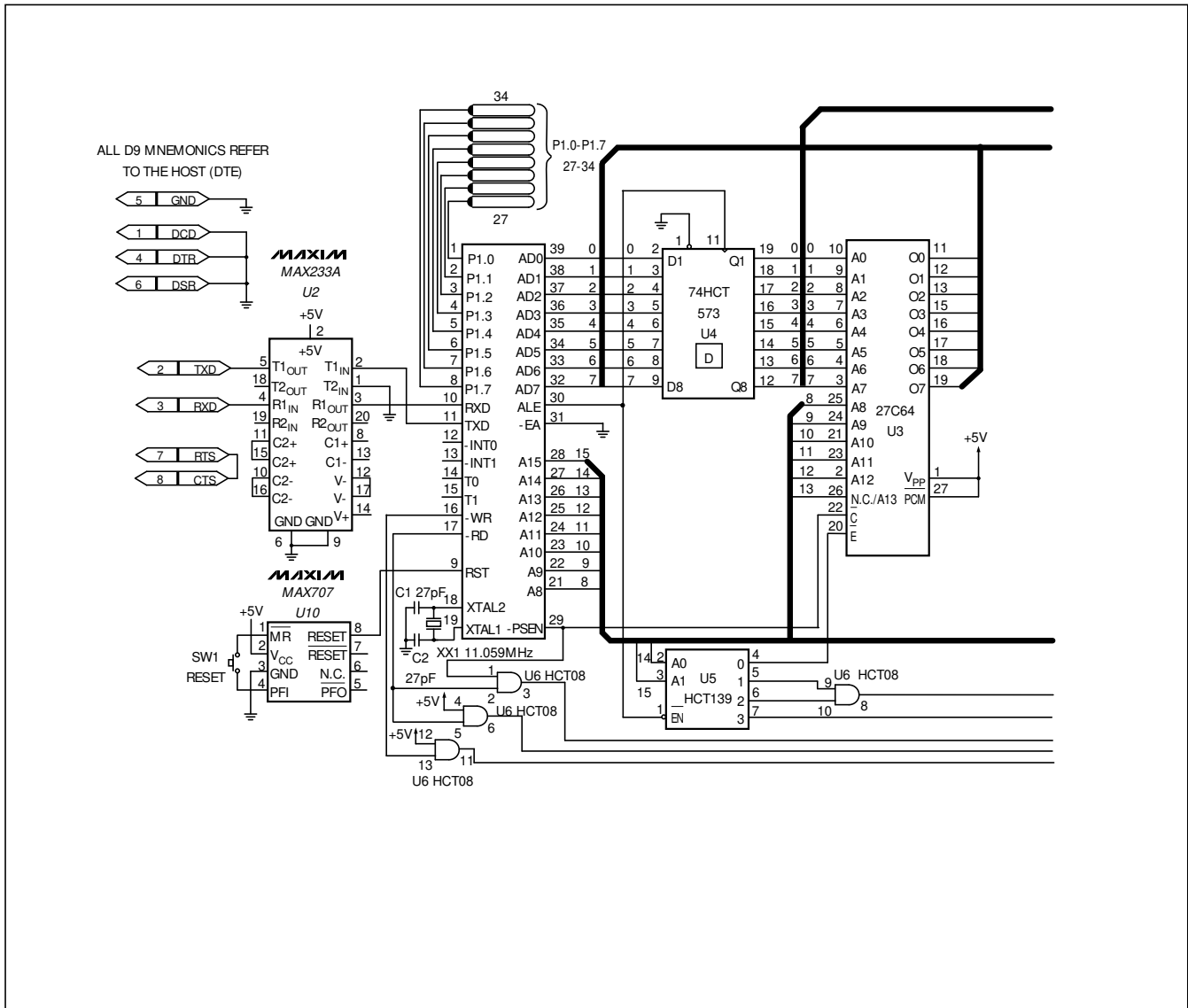

Figure 6. 80C32 Module Schematic

MAX186 Evaluation System/Evaluation Kit

Evaluates: MAX186

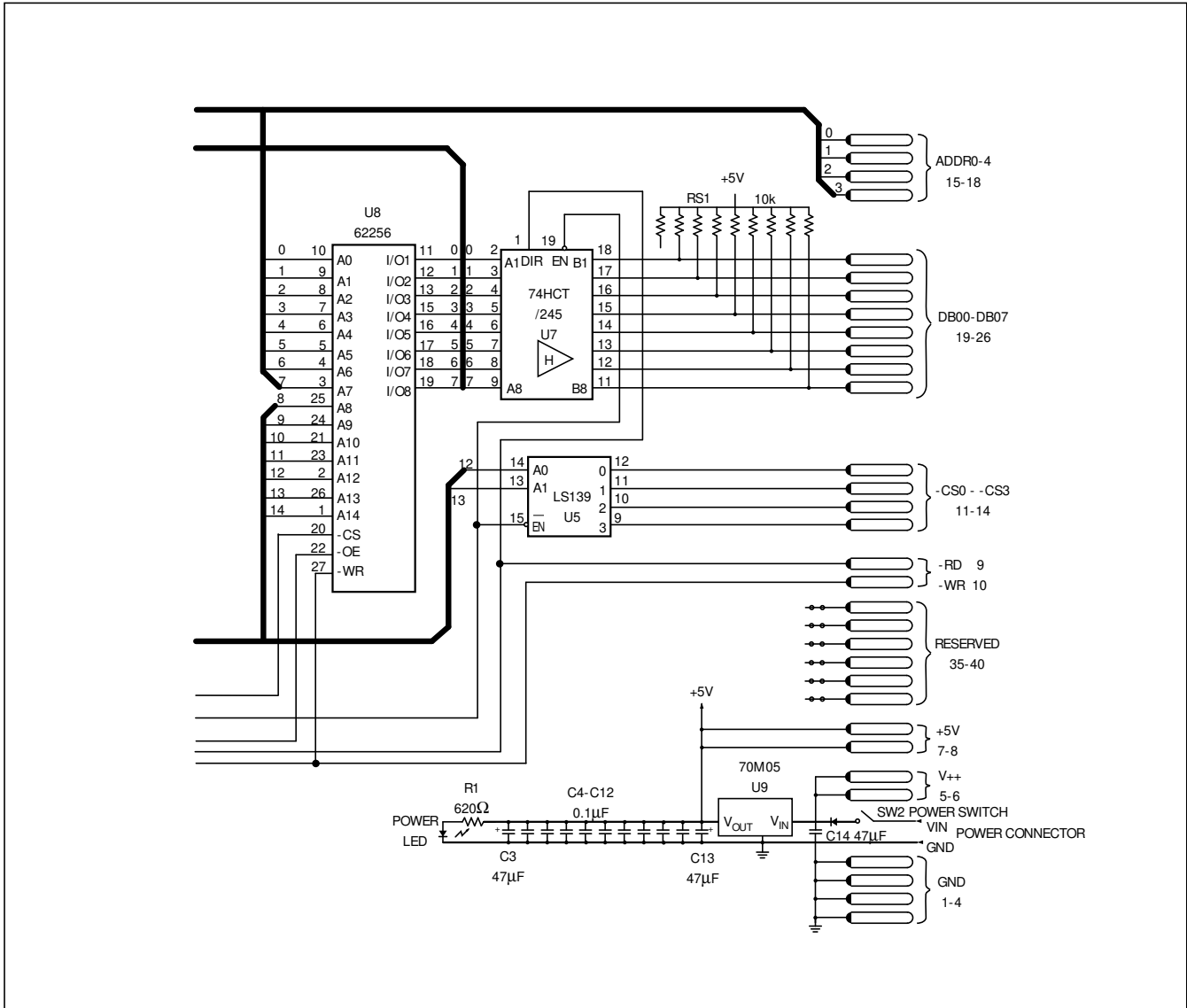

Figure 6. 80C32 Module Schematic (continued)

MAX186 Evaluation System/Evaluation Kit

Evaluates: MAX186

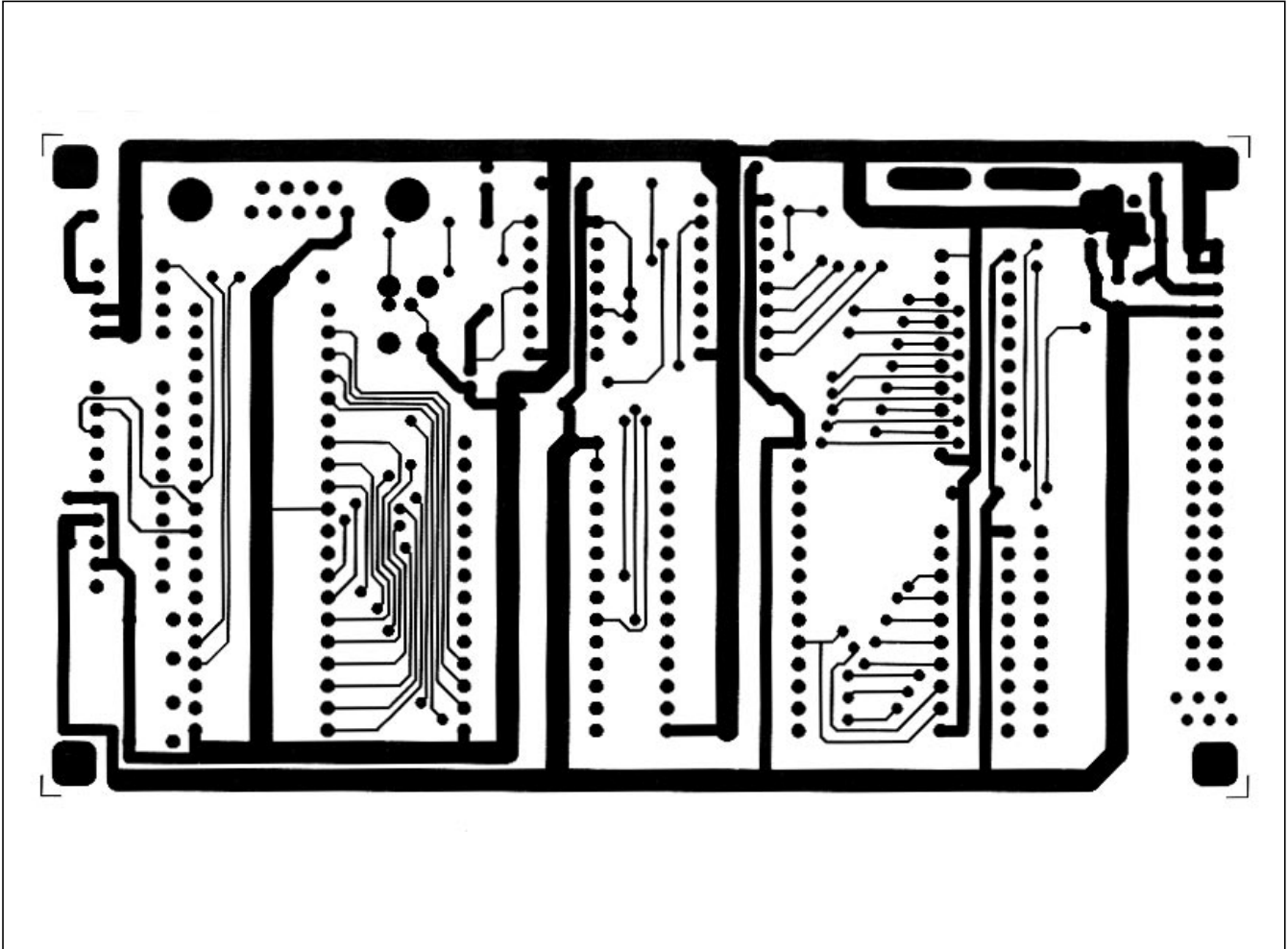

Figure 7. 80C32 Module Component- Side Layout (x2)

MAX186 Evaluation System/Evaluation Kit

Evaluates: MAX186

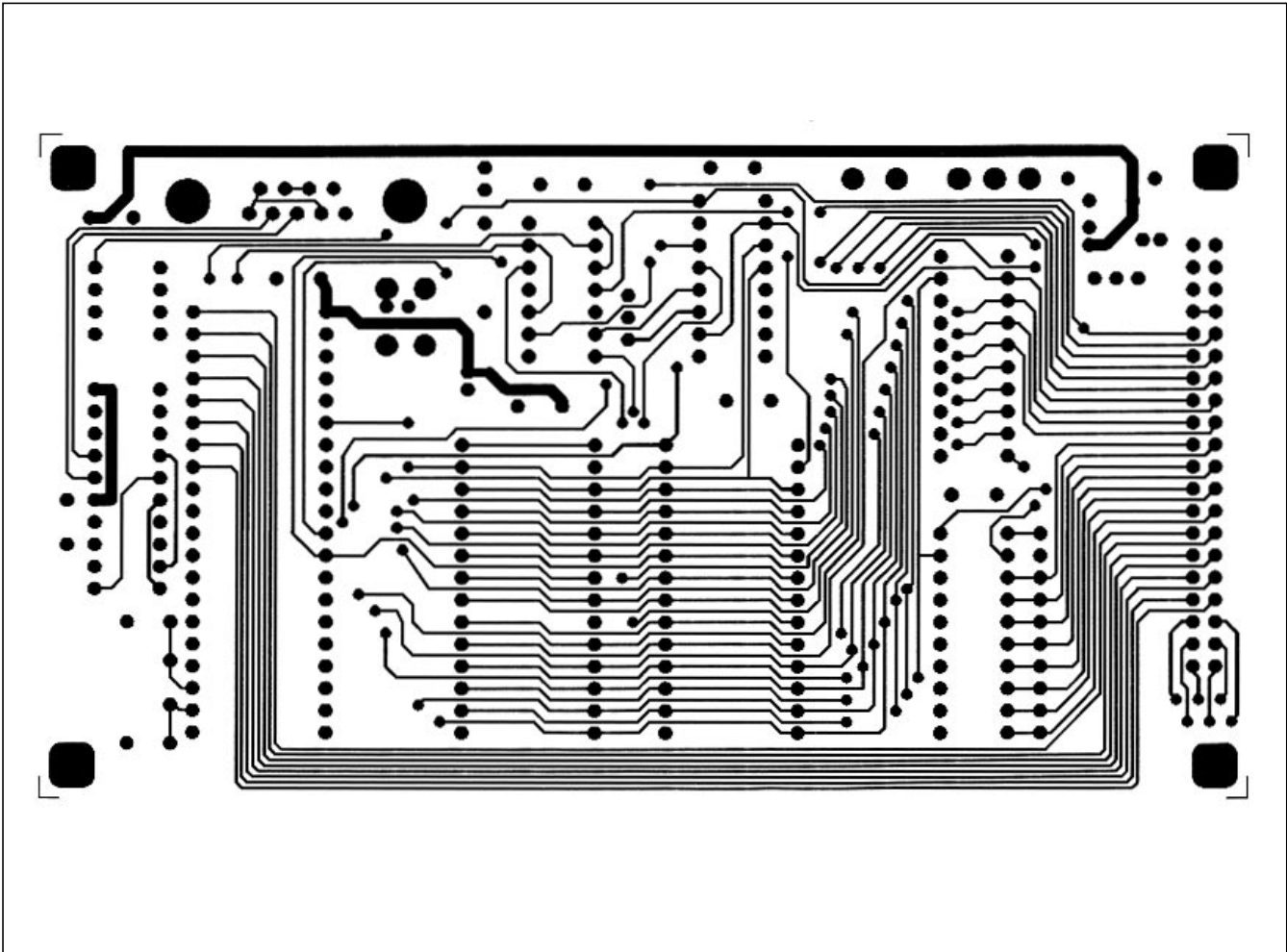

Figure 8. 80C32 Module Solder-Side Layout (x2)

MAX186 Evaluation System/Evaluation Kit

Evaluates: MAX186

Maxim cannot assume responsibility for use of any circuitry other than circuitry entirely embodied in a Maxim product. No circuit patent licenses are implied. Maxim reserves the right to change the circuitry and specifications without notice at any time.

20 _____ Maxim Integrated Products, 120 San Gabriel Drive, Sunnyvale, CA 94086 (408) 737-7600

© 1996 Maxim Integrated Products

Printed USA

MAXIM is a registered trademark of Maxim Integrated Products.