

- PINS TO COMPLY WITH AMP SOLDERABILITY SPEC. 108-11-3.
- 0.00381 MIN MATTE TIN LEAD OVER 0.00127 MIN NICKEL.
- 0.00076 MIN GOLD PLATE IN THE LOCALIZED PLATE AREA, 0.00381 MATTE TIN LEAD IN THE LOCALIZED PLATE AREA, BOTH OVER 0.00127 MIN NICKEL.
- 0.00381 MIN MATTE TIN OVER 0.00127 MIN NICKEL.
- 0.00076 MIN GOLD PLATE IN THE LOCALIZED PLATE AREA, 0.00381 MATTE TIN IN THE LOCALIZED PLATE AREA, BOTH OVER 0.00127 MIN NICKEL.

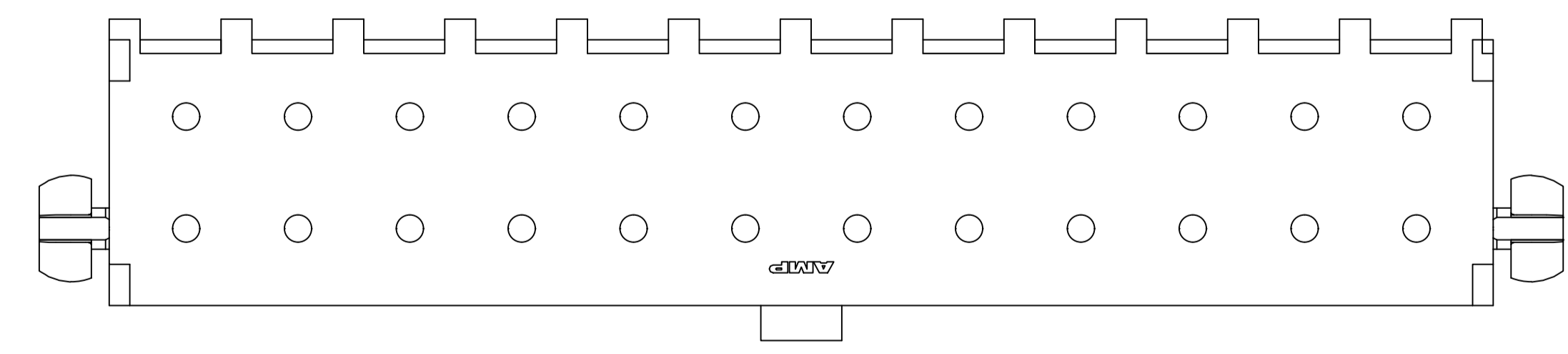
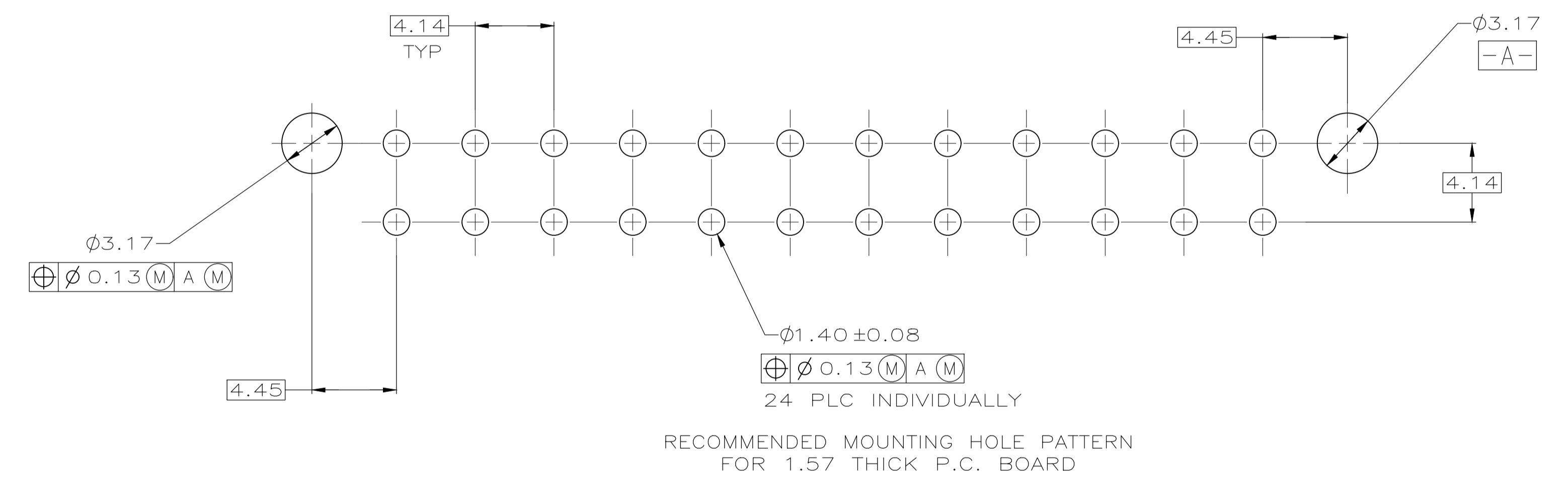
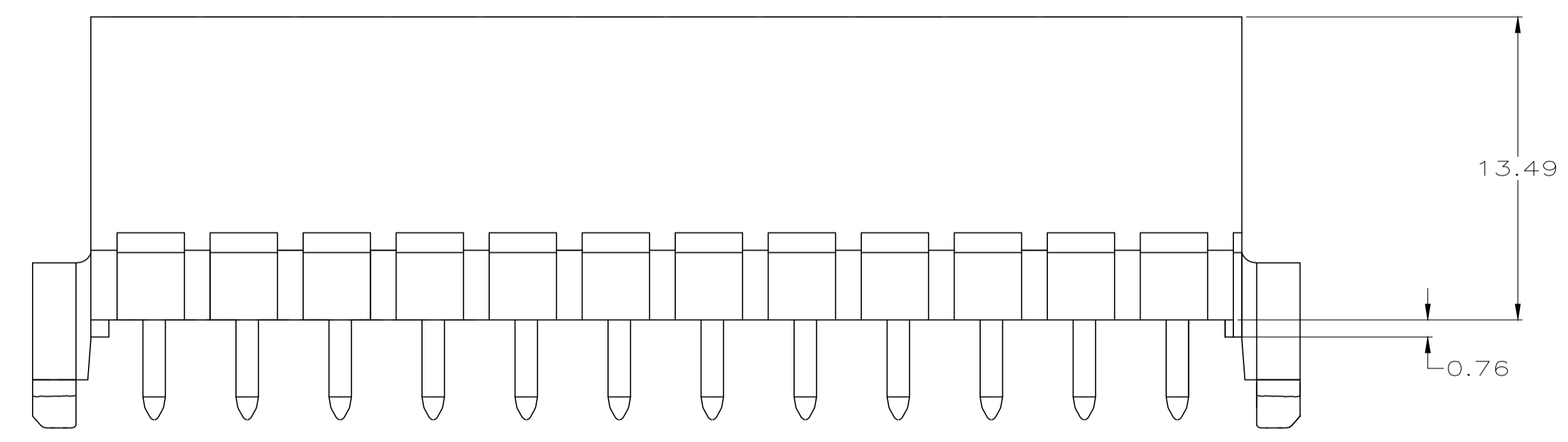
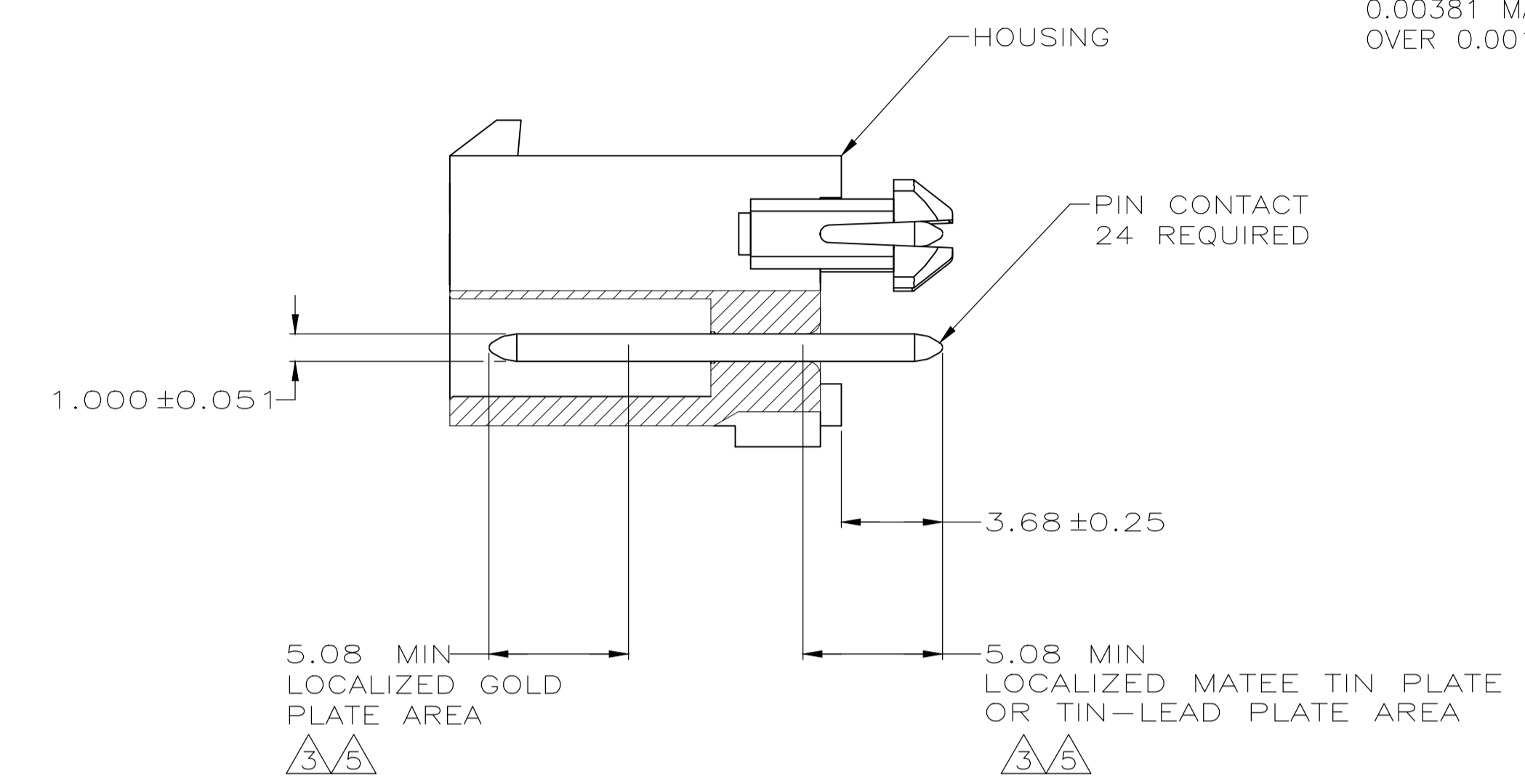
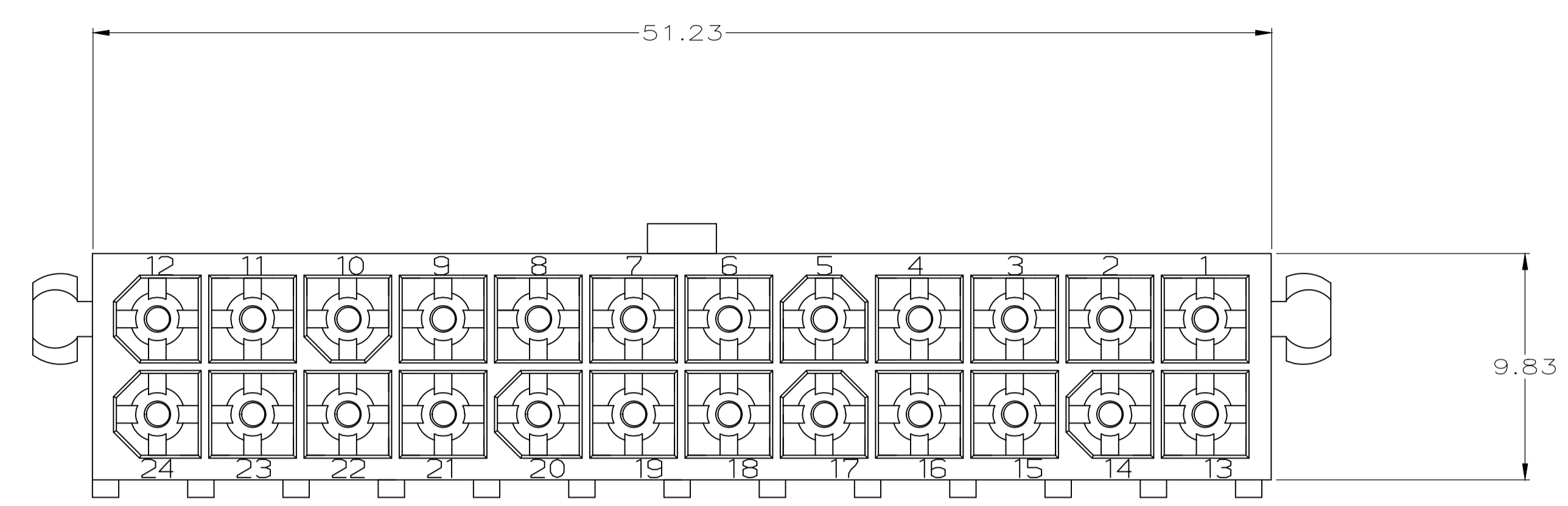

	BRASS, GOLD	NYLON, 94V-0, WHITE	1-794079-1
	BRASS, TIN	NYLON, 94V-0, WHITE	1-794079-0
OBSOLETE	BRASS, GOLD	NYLON, 94V-0, WHITE	794079-2
OBSOLETE	BRASS, TIN LEAD	NYLON, 94V-0, WHITE	794079-1
PIN CONTACT MATERIAL AND FINISH		HOUSING MATERIAL AND COLOR	PART NUMBER

THIS DRAWING IS A CONTROLLED DOCUMENT.

DIMENSIONS: mm	TOLERANCES UNLESS OTHERWISE SPECIFIED:	DWN: K. WHITAKER 6-12-95	CHK: R. SWING 6-12-95	APVD: R. ORSTAD 6-13-95	NAME: R. ORSTAD
0 PLC ± -	1 PLC ± -	STE TE Connectivity			
2 PLC ± 0.13	3 PLC ± -	HEADER ASSEMBLY, CLOSED BOTTOM, 24 CIRCUIT, DOUBLE ROW VERTICAL, MINI-UNIVERSAL MATE-N-LOK			
4 PLC ± -	ANGLES ± -	SIZE: A1	CAGE CODE: 00779	DRAWING NO: 794079	RESTRICTED TO: -
MATERIAL: SEE TABLE	FINISH: SEE TABLE	WEIGHT: -	SCALE: 5:1	SHEET: 1 OF 1	REV: E2

CUSTOMER DRAWING