

STRAIGHT BULKHEAD PLUG SOLDER TYPE

R128.052.000

CABLE .085

Series : BMA

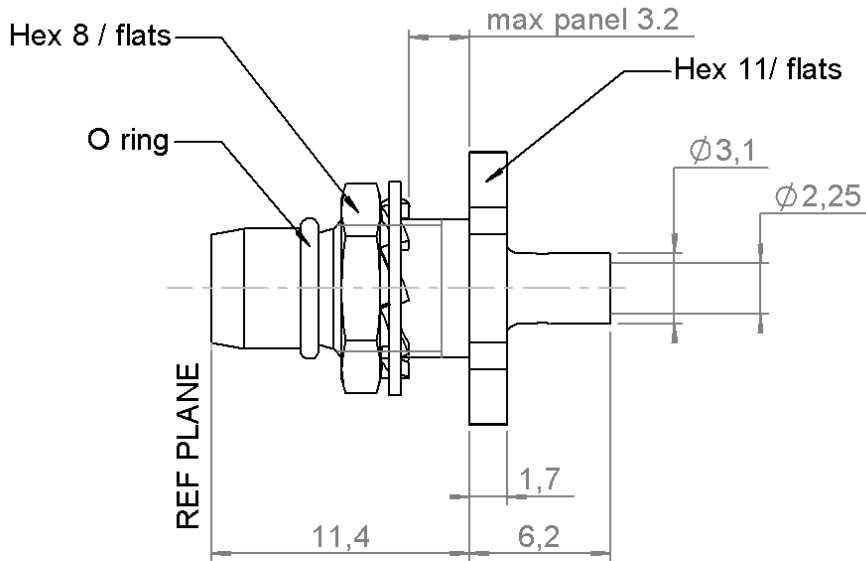

PANEL CUT OUT

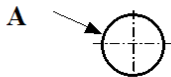

mm		
	Maxi	mini
A	6.175	6.15

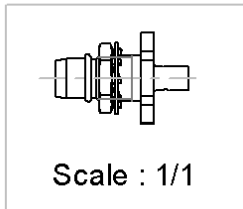
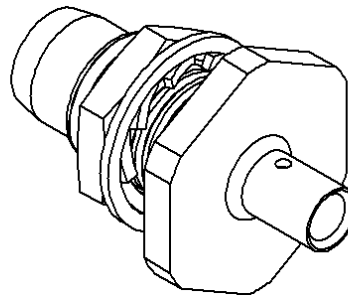

All dimensions are in mm.

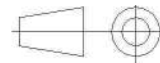

COMPONENTS	MATERIALS	PLATINGS (µm)
BODY	STAINLESS STEEL	GOLD 0.5 OVER NICKEL 2
CENTER CONTACT	BERYLLIUM COPPER	GOLD 1.3 OVER NICKEL2
OUTER CONTACT	-	-
INSULATOR	PTFE	-
GASKET	SILICONE RUBBER	-
OTHERS PARTS	BRASS	NICKEL 2
-	-	-
-	-	-

Issue : 1301 C

In the effort to improve our products, we reserve the right to make changes judged to be necessary.



STRAIGHT BULKHEAD PLUG SOLDER TYPE

R128.052.000

CABLE .085

Series : BMA

PACKAGING

Standard	Unit	Other
100	OPTION W	Contact us

SPECIFICATION

CABLE ASSEMBLY

ELECTRICAL CHARACTERISTICS

Stripping	a	b	c	d	e	f
mm	1,78	0,00	0,00	0,00	0,00	0,00

Impedance	50	Ω
Frequency	0-22	GHz
VSWR	1.07 + 0,0100	x F(GHz) Maxi
Insertion loss	0.03	\sqrt{F} (GHz) dB Maxi
RF leakage	- (NA)	- F(GHz) dB mini
Voltage rating	350	Veff Maxi
Dielectric withstanding voltage	1000	Veff mini
Insulation resistance	5000	M Ω mini

Assembly instruction :

Recommended cable(s)
KS 1
RG 405

Cable retention

- pull off **136** N mini
- torque **NA** N.cm

MECHANICAL CHARACTERISTICS

TOOLING

Center contact retention		
Axial force – Mating end	27	N mini
Axial force – Opposite end	27	N mini
Torque	NA	N.cm mini

Part Number	Description	Hexagon
.	.	.
R282.051.000	STRIPPING TOOL	
R282.062.000	POINTER GAUGE	
R282.740.000	SOLDERING MOUNTING	
R282.860.100	SOLDERING POSITIONER	

Recommended torque		
Mating	NA	N.cm
Panel nut	150	N.cm
Clamp nut	NA	N.cm
A/F clamp nut	0,0000	mm

OTHERS CHARACTERISTICS

Mating life	1000	Cycles mini
Weight	0,0000	g

ENVIRONMENTAL

Operating temperature	-65/+125	$^{\circ}$ C
Hermetic seal	NA	Atm.cm3/s
Panel leakage	NA	

Issue : 1301 C

In the effort to improve our products, we reserve the right to make changes judged to be necessary.



STRAIGHT BULKHEAD PLUG SOLDER TYPE

R128.052.000

CABLE .085

Series : BMA

COMPONENTS

BODY

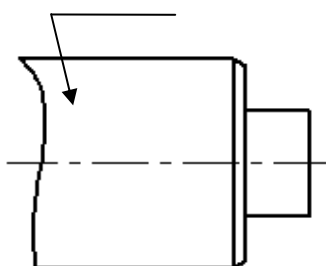

STIPPING DIMENSIONS

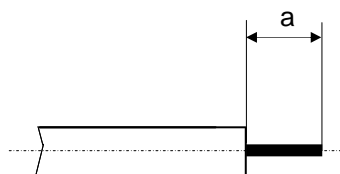

1

- Strip the cable with the cable stripping tool.
- Trim the cable inner conductor with the trimmer.
- Clean the cable

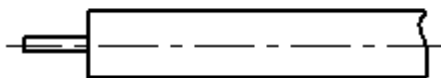

2

- Introduce the cable into the body until contact with the body shoulder..
- Place the sub-assembly on assembly jig
- Solder body on the cable.
- Let assembly cool down before removing it from the jig.

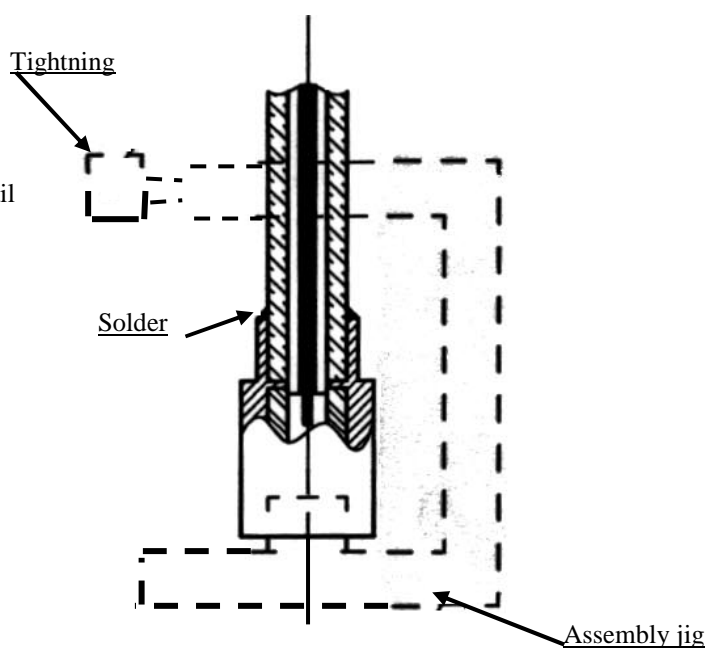

Issue : 1301 C

In the effort to improve our products, we reserve the right to make changes judged to be necessary.



RADIALL®