



# **PE4140 EVALUATION KIT USER'S MANUAL**

6175 Nancy Ridge Drive, San Diego, CA 92121  
(858) 455-0660, Fax (858) 455-0770  
<http://www.peregrine-semi.com>

© Copyright 2002 Peregrine Semiconductor Corp. All rights reserved. Printed in the United States of America. No part of this publication may be reproduced, photocopied, stored in a retrieval system, or transmitted by electronic, mechanical or any other means without prior written permission of Peregrine Semiconductor Corp.

Peregrine Semiconductor Corp., the Peregrine logotype, and UTSi are registered trademarks of Peregrine Semiconductor Corp. PE9722 is a trademark of Peregrine Semiconductor Corp.

Peregrine Semiconductor Corp. reserves the right to make improvements to the hardware, firmware or software described in this manual at any time and without notice. While the accompanying material has been carefully reviewed to insure the most accurate information possible, the data are not warranted for absolute accuracy or completeness and are subject to change without notification.

### **Peregrine Semiconductor Corp. Life Support Policy**

Peregrine Semiconductor Corp. products are not intended for use in life-critical situations, or as critical components in life-support devices or systems.

Life-support devices or systems are defined as devices or systems that are intended for surgical implant into the body, or that support or sustain life, and whose failure to perform when used in accordance with the instructions provided by the manufacturer, might result in injury to the user.

### **FCC Compliance Statement**

This device is intended for use only in a research and development environment. It has not been tested for compliance with FCC regulations regarding interference with radio frequency energy. It might cause harmful interference with radio communications. The user assumes responsibility for any interference caused by this device.

## Introduction

This Evaluation Kit is specifically designed for evaluating the PE4140 FET Quad. The Evaluation kit consist of a Tested PE4140 mounted to the PCB. Schematics have been supplied for a CATV up-converter as well as a PCS band down-converter. The general schematic of the evaluation board will allow a wide variety of user-defined applications.

## Applications Support

If you have a problem with your evaluation kit, software, or if you have applications questions call **(858) 455-0660** and ask for applications support.

You may also contact us by fax or e-mail:

Fax: **(858) 455-0770**

E-Mail: **help@peregrine-semi.com**

## FCC Labeling Requirement

This device complies with Part 15 of the FCC Rules. Operation is subject to the following two conditions: (1) this device may cause harmful interference, and (2) this device must accept any interference received including interference that may cause undesired operation.

*CAUTION: The PE4140-EK circuit contains components that might be damaged by exposure to voltages in excess of the specified voltage, including voltages produced by electrostatic discharges. Handle the board in accordance with procedures for handling static-sensitive components.*

# Schematic

The PC board provides a number of solder footprints to accommodate various surface mount devices that can be used to optimize performance over specific operating bands. Typically, these components will perform impedance matching to the device, especially at the LO terminals. Figure 1 shows all the possible components that could be added to the board design; each place is represented nominally with a resistor reference designator (although inductors and capacitors will normally be used for matching). Note that the board's underlying traces must first be cut to add series components, and certain ground vias may also need to be removed to insert other components (i.e. R5, R14 at the LO port).

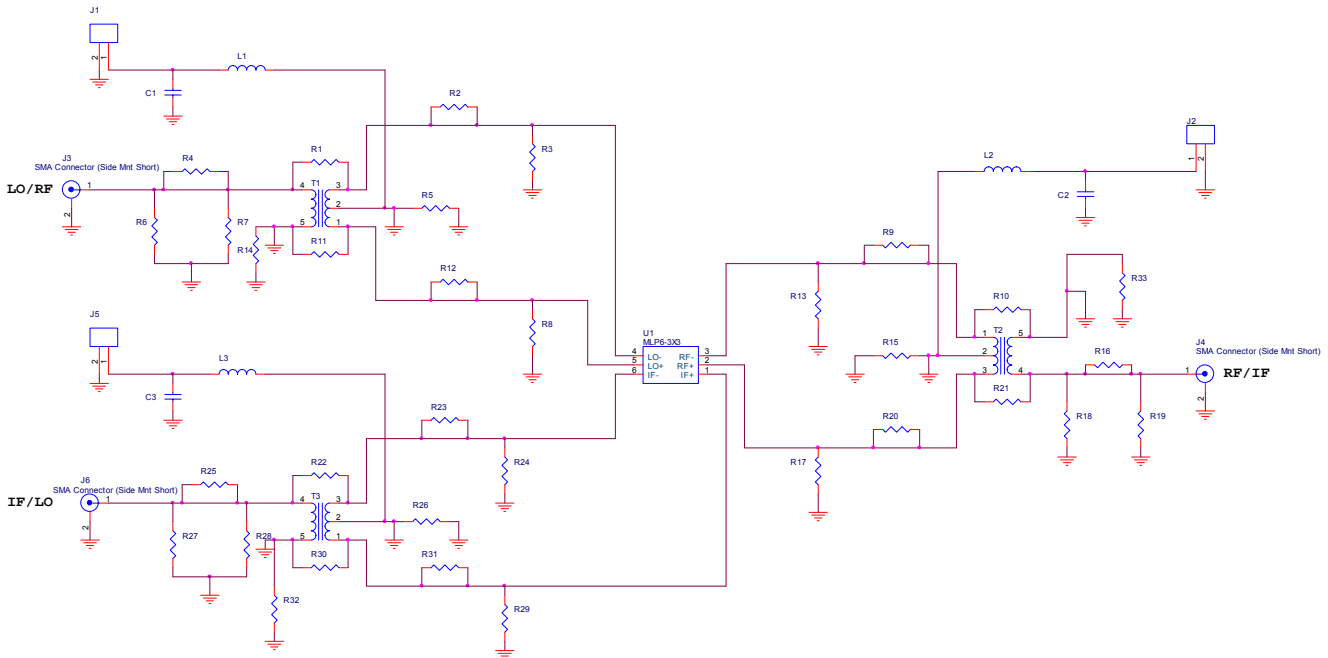

Figure 1 Evaluation Board Schematic

# Evaluation Board Layout

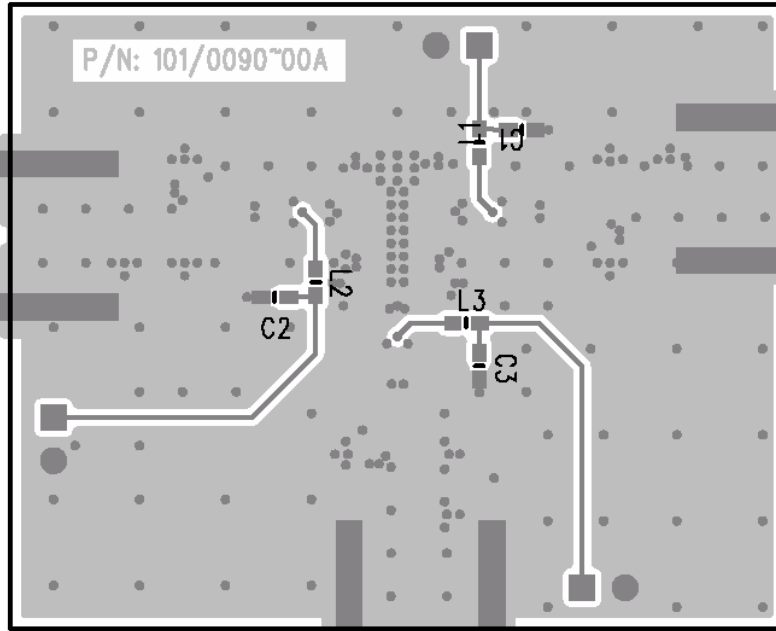

Figure 2 Evaluation Board Bottom Side

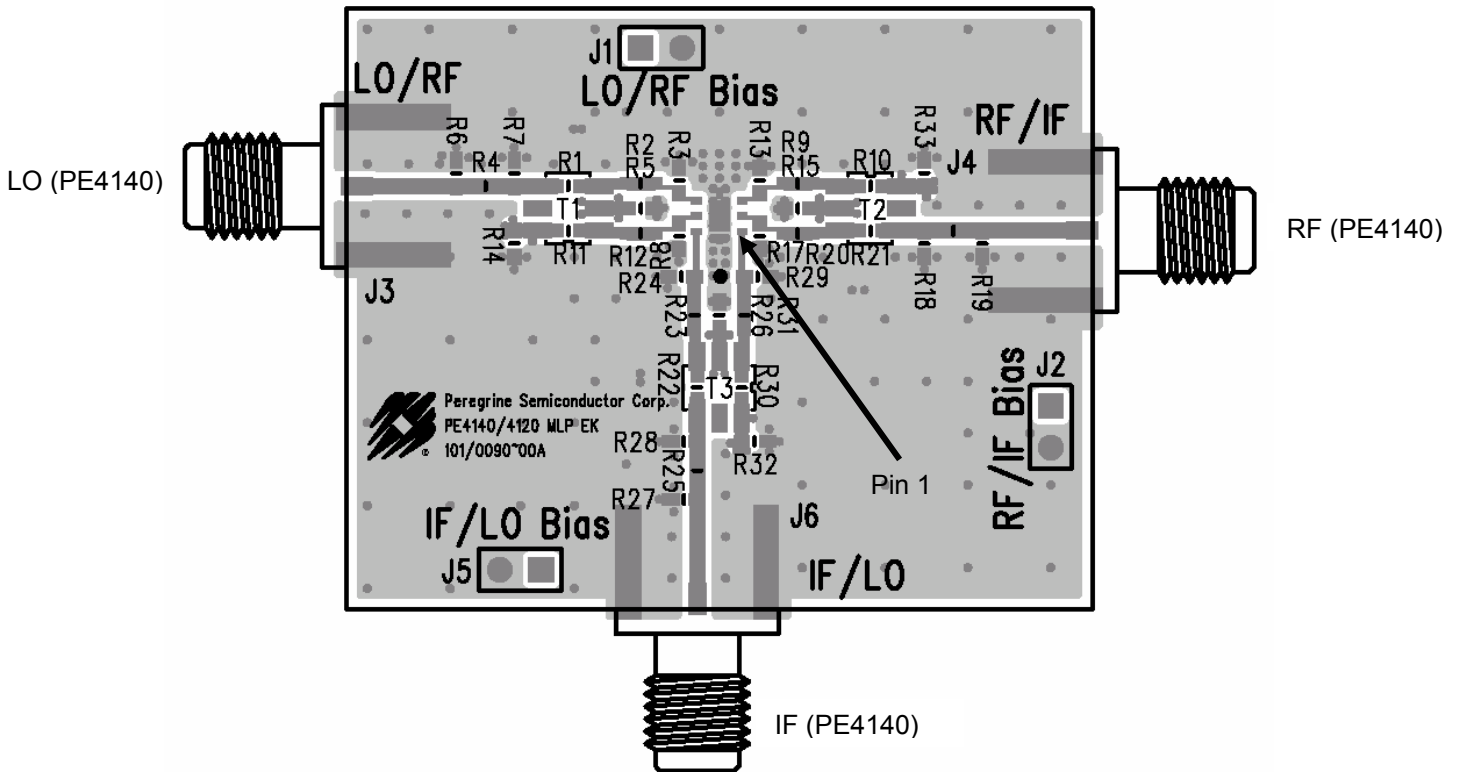
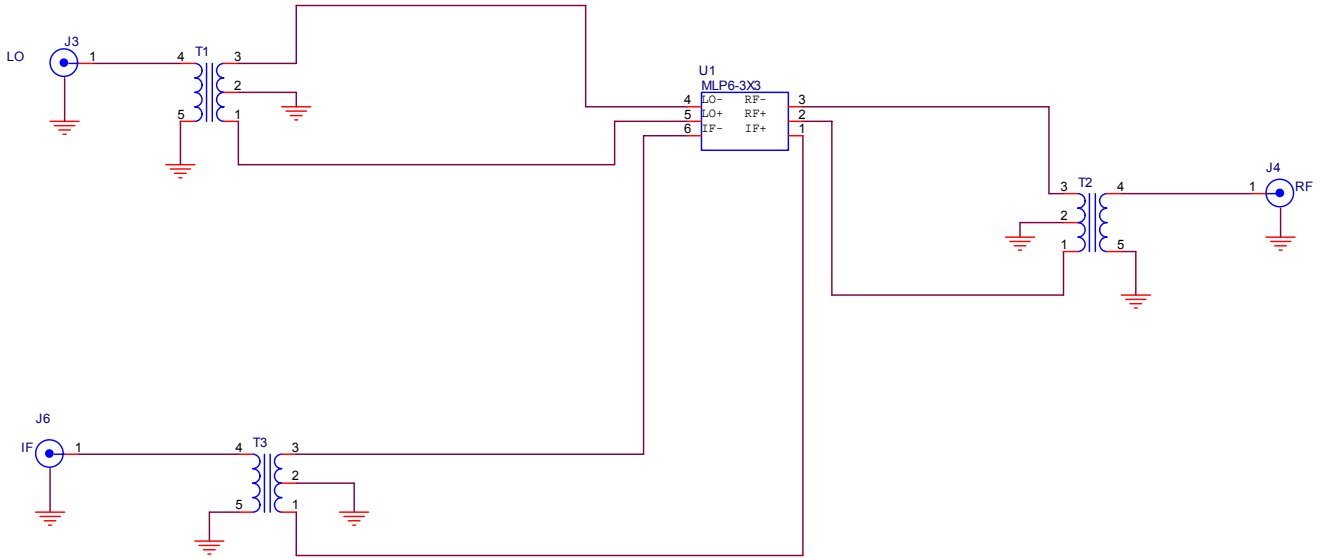

Figure 3 Evaluation Board Topside

# PE4140 in Mixer Applications

The PE4140 is inherently a broadband device, capable of operating as a broadband mixer by adding a few external parts. At a minimum, three transformers are required to create a double-balanced mixer. This is shown in Figure 4 below. The PC board provides solder footprints to accept this circuit without any modifications. Figure 5 shows a schematic with component values for a PCS down Converter.



**Figure 4 Schematic for Double- Balanced Mixer**

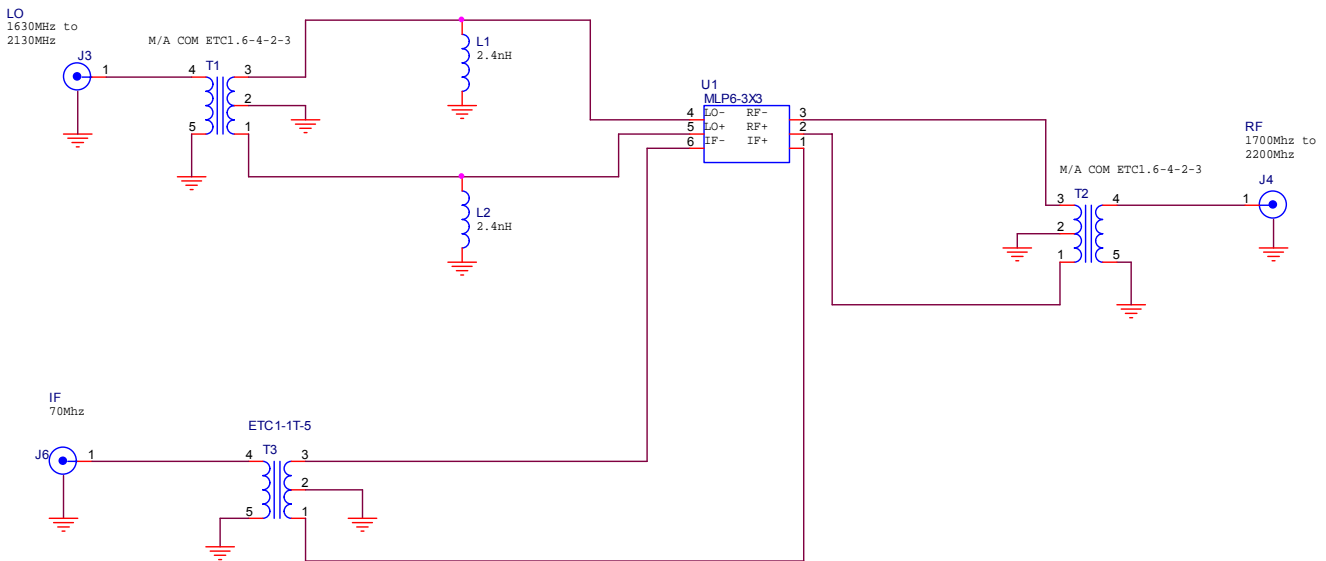

**Figure 5 Typical schematic for PCS Application**

# PE4140 in a Broadband CATV Upconverter

Matching placed at the LO port can greatly affect the efficiency with which applied LO power drives the gates of the FETs. This can have a great affect on the IIP3 performance of a mixer. An example of this is shown in the *PE4140 CATV Upconverter* schematic. Placing a shunt 4.7nH inductor at each LO pin of the PE4140 improves LO power transfer over the 1 to 2 GHz band, increasing the IIP3 of the mixer by about 5dB from a circuit with no LO port matching.

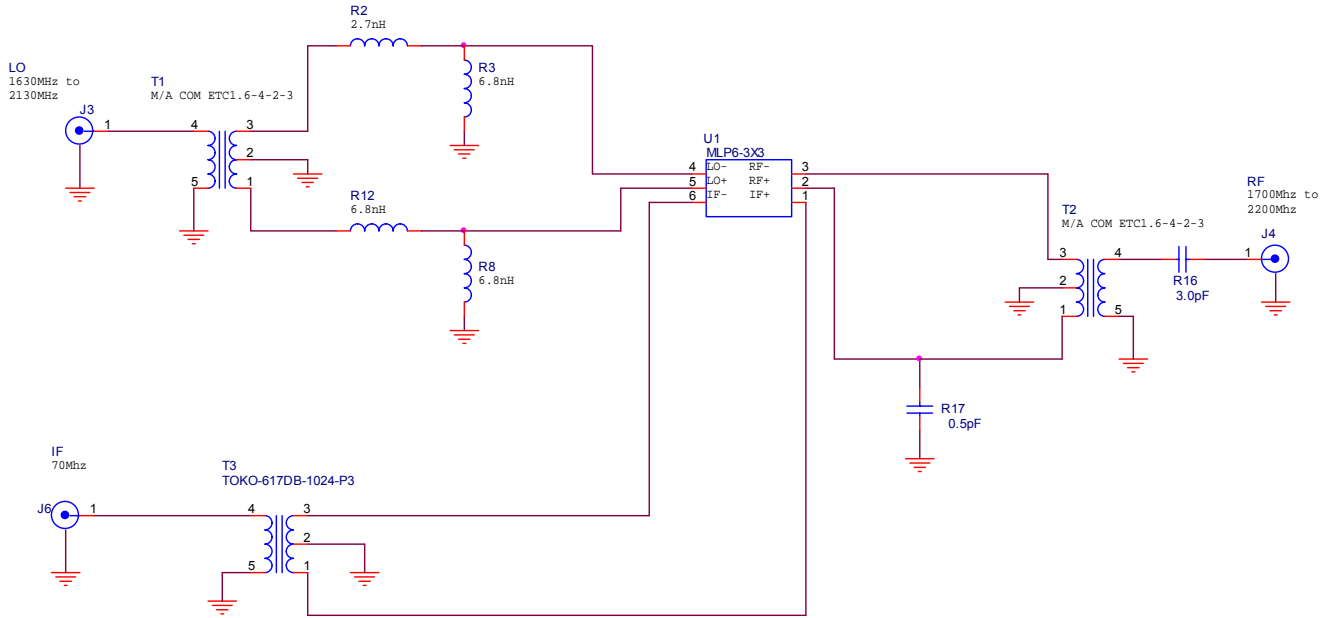

Component Reference designators Refer to Evaluation board 101/0090-00A

**Figure 6 Typical schematic for CATV Application**