



# MPQ6524

## Quad Half-Bridge Motor Driver with Serial Input Control

---

### DESCRIPTION

The MPQ6524 is a four half-bridge, DMOS, output driver with integrated power MOSFETs that can drive up to four different loads.

The four half-bridges can be controlled separately from a standard serial data interface and have various diagnostic functions. The MPQ6524 has very low quiescent current in standby mode, making it suitable for a wide range of applications.

Full protection features include short-circuit protection (SCP), under-voltage protection (UVP), and thermal shutdown.

The MPQ6524 requires a minimal number of readily available, standard, external components and is available in a QFN-24 (4mmx4mm) package.

### FEATURES

- Up to 0.9A Output Current
- Total Max Current 2.4A (All Outputs Combined)
- $R_{DS(ON)}$  (HS + LS) Typically 1.1 $\Omega$  at 25°C, Maximum 2 $\Omega$  at 150°C
- Very Low Quiescent Current  $I_{VS} < 6\mu A$  in Standby Mode Versus Total Temperature Range
- Outputs Short-Circuit Protected
- Over-Temperature Protection (OTP) and Pre-Warning
- Under-Voltage Protection (UVP)
- Serial Data Interface
- Various Diagnostic Functions: Shorted Output, Open-Load, Over-Temperature, and Under-Voltage
- Fault Output Flag
- Daisy Chaining Possible
- Up to 3MHz Serial Interface Clock Frequency, 3.3V and 5V Compatible
- Available in a QFN-24 (4mmx4mm) Package
- Available in a Wettable Flank Package
- Available in AEC-Q100 Grade 1

### APPLICATIONS

- Drive Various Loads in Automotive and Industrial Applications
- DC Motors

---

All MPS parts are lead-free, halogen-free, and adhere to the RoHS directive. For MPS green status, please visit the MPS website under Quality Assurance. "MPS", the MPS logo, and "Simple, Easy Solutions" are trademarks of Monolithic Power Systems, Inc. or its subsidiaries.

## TYPICAL APPLICATION

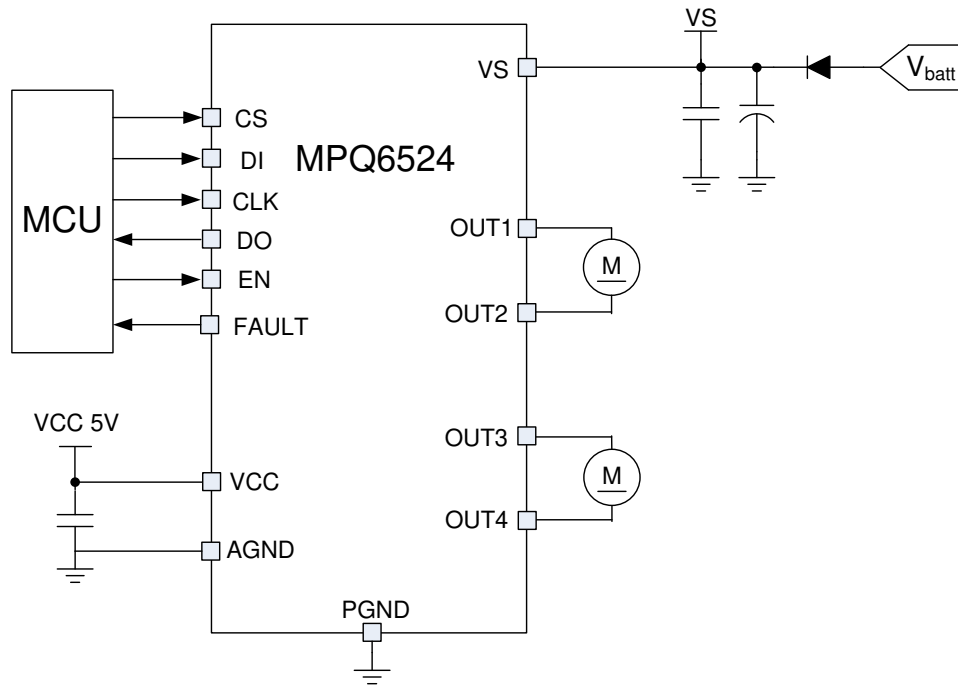

### ORDERING INFORMATION

Part Number*	Package	Top Marking
MPQ6524GRE-AEC1	QFN-24 (4mmx4mm)	See Below

\*For Tape & Reel, add suffix -Z (e.g. MPQ6524GRE-AEC1-Z).

### TOP MARKING

**MPSYWW**

**MP6524**

**LLLLLL**

MPS: MPS prefix  
 Y: Year code  
 WW: Week code  
 MP6524: Product code of MPQ6524GRE-AEC1  
 LLLLLL: Lot number

### PACKAGE REFERENCE

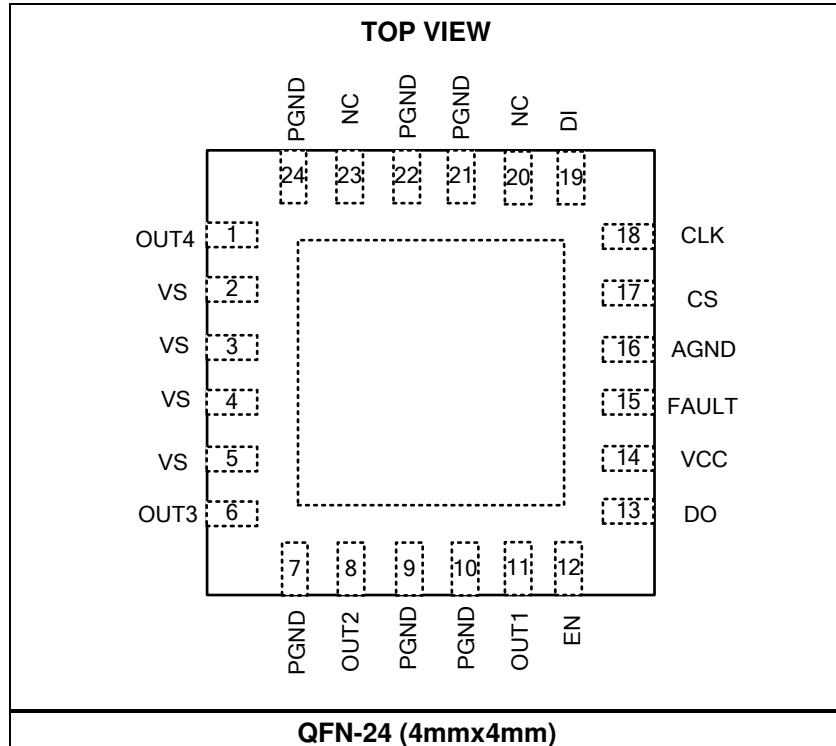

## PIN FUNCTIONS

QFN-24 (4x4) Pin #	Name	Description
1	OUT4	Half-bridge output 4.
2 - 5	VS	Power supply.
6	OUT3	Half-bridge output 3.
7, 9, 10, 21, 22, 24	PGND	Power ground.
8	OUT2	Half-bridge output 2.
11	OUT1	Half-bridge output 1.
12	EN	Enable. Drive EN low for standby mode. Drive EN high for normal operation.
13	DO	Serial data output.
14	VCC	Logic supply voltage.
15	FAULT	Fault output. A low output at FAULT indicates that the IC has detected an over-temperature or over-current condition. This output is open-drain.
16	AGND	Analog ground.
17	CS	Chip select input.
18	CLK	Serial clock input.
19	DI	Serial data input.
20, 23	NC	No connection.

### ABSOLUTE MAXIMUM RATINGS <sup>(1)</sup>

Supply voltage (V <sub>VS</sub> )	40V
V <sub>OUTx</sub>	-0.3 to V <sub>VS</sub> + 0.3V
Logic supply voltage (V <sub>VCC</sub> )	-0.3 to +6.5V
Logic input voltage	-0.3 to V <sub>VCC</sub> + 0.3V
Logic output voltage	-0.3 to V <sub>VCC</sub> + 0.3V
Voltage at all other pins	-0.3 to +6.5V
Continuous power dissipation (T <sub>A</sub> = 25°C) <sup>(2)</sup>	
QFN-24 (4mmx4mm)	3W
Junction temperature	150°C
Lead temperature	260°C
Storage temperature	-60°C to +150°C

### ESD Ratings <sup>(3)</sup>

Human body mode (HBM)	2kV
Machine mode (MM)	200V
Charge device model (CDM)	750V

### Recommended Operating Conditions <sup>(4)</sup>

Supply voltage (V <sub>VS</sub> )	7V to 28V
Logic supply voltage (V <sub>VCC</sub> )	3.15V to 5.25V
Operating junction temp. (T <sub>J</sub> )	-40°C to +150°C

<b>Thermal Resistance <sup>(5)</sup></b>	<b>θ<sub>JA</sub></b>	<b>θ<sub>JC</sub></b>
QFN-24 (4mmx4mm)	42.....	9 .... °C/W

#### Notes:

- Exceeding these ratings may damage the device.
- The maximum allowable power dissipation is a function of the maximum junction temperature T<sub>J</sub> (MAX), the junction-to-ambient thermal resistance θ<sub>JA</sub>, and the ambient temperature T<sub>A</sub>. The maximum allowable continuous power dissipation at any ambient temperature is calculated by P<sub>D</sub> (MAX) = (T<sub>J</sub> (MAX) - T<sub>A</sub>) / θ<sub>JA</sub>. Exceeding the maximum allowable power dissipation can produce an excessive die temperature, and may cause the device to go into thermal shutdown. Internal thermal shutdown circuitry protects the device from permanent damage.
- Devices are ESD-sensitive. Handling precaution is recommended.
- The device is not guaranteed to function outside of its operating conditions.
- Measured on JESD51-7, 4-layer PCB.

## ELECTRICAL CHARACTERISTICS

7V < V<sub>VS</sub> < 28V, V<sub>VCC</sub> = 5V, T<sub>A</sub> = -40°C to +125°C, unless otherwise noted.

Parameters	Symbol	Condition	Min	Typ	Max	Units
Operating supply current (VS)	I <sub>VS</sub>	V <sub>VS</sub> < 28V normal operation, all output stages off		2.2	6	mA
		V <sub>VS</sub> < 28V normal operation, all output low stages on, no load		2.65	6	
		V <sub>VS</sub> < 28V normal operation, all output high stages on, no load		2.7	6	
Operating supply current (VCC)	I <sub>VCC</sub>	4.75V < V <sub>VCC</sub> < 5.25V, normal operation		65	90	μA
Quiescent current (VS)	I <sub>VS</sub>	V <sub>VS</sub> = 28V, V <sub>VCC</sub> = 0V or V <sub>VCC</sub> = 5V, EN = low, or V <sub>VCC</sub> = 5V, bit SE = low, output pins to VS and GND		1.5	6	μA
Quiescent current (VCC)	I <sub>VCC</sub>	4.75V < V <sub>VCC</sub> < 5.25V, EN or bit SE = low		23	35	μA
Discharge current (VS)	I <sub>VS</sub>	V <sub>VS</sub> = 40V, EN = low			3	mA
Internal oscillator frequency	f <sub>OSC</sub>		85	120	166	kHz
Power-on reset threshold	V <sub>VCC</sub>		2.3	2.6	3.0	V
Power-on reset delay		After switching on V <sub>VCC</sub>	30	100	190	μs
Under-voltage lockout threshold rising			5.5		6.5	V
Under-voltage lockout threshold hysteresis				0.6		V
Under-voltage lockout delay time			7	14	23	ms
<b>Output Specification</b>						
HS + LS switch-on resistance	R <sub>DS(ON)</sub>	T <sub>J</sub> = -40°C to +125°C		1.1	1.7	Ω
		T <sub>J</sub> = +150°C <sup>(6)</sup>			2	Ω
Inductive shutdown energy <sup>(7)</sup>					15	mJ
Over-current limit	IOCP		1	1.3	1.8	A
Over-current shutdown delay time		Bit14 (SCT) = low, V <sub>VS</sub> = 13V	0.1	0.21	0.3	ms
		Bit14 (SCT) = high, V <sub>VS</sub> = 13V	0.28	0.53	0.72	
Open-load detection current		Bit13 (OLD) = low, output off	1.4	1.9	2.4	mA
Output switch-on/-off delay		V <sub>VS</sub> = 13V, R <sub>LOAD</sub> = 50Ω			60	μs
OUTx rising time		V <sub>VS</sub> = 13V, 10% to 90% V <sub>OUT</sub> , R <sub>LOAD</sub> = 50Ω	2	20	50	μs
OUTx falling time		V <sub>VS</sub> = 13V, 10% to 90% V <sub>OUT</sub> , R <sub>LOAD</sub> = 50Ω	2	20	45	μs
Dead time		V <sub>VS</sub> = 13V, R <sub>LOAD</sub> = 50Ω	2			μs
<b>EN Input</b>						
EN low-level threshold					0.8	V
EN high-level threshold			3	1.7		V
Pull-down current of EN input		V <sub>EN</sub> = V <sub>VCC</sub>	10		80	μA

**ELECTRICAL CHARACTERISTICS** (continued)

7V < V<sub>VS</sub> < 28V, V<sub>VCC</sub> = 5V, T<sub>A</sub> = -40°C to +125°C, unless otherwise noted.

Parameters	Symbol	Condition	Min	Typ	Max	Units
<b>Thermal Shutdown and Pre-Warning <sup>(7)</sup></b>						
Thermal pre-warning threshold			120	145	170	°C
Thermal pre-warning hysteresis				15		°C
Thermal shutdown threshold			150	175	200	°C
Thermal shutdown hysteresis				15		°C
Ratio thermal shutdown/thermal pre-warning			1.05	1.2		

## SERIAL INTERFACE TIMING ELECTRICAL CHARACTERISTICS <sup>(7)</sup>

7V < V<sub>VS</sub> < 28V, V<sub>VCC</sub> = 5V, T<sub>A</sub> = -40°C to +125°C, unless otherwise noted.

Parameters	Symbol	Condition	Min	Typ	Max	Units
<b>Logic Inputs (DI, CLK, CS)</b>						
Input low-level threshold					0.3 x V <sub>VCC</sub>	V
Input high-level threshold			0.7 x V <sub>VCC</sub>			V
Pull-down current of DI, CLK		V <sub>DI</sub> , V <sub>CLK</sub> = V <sub>VCC</sub>	2		50	μA
Pull-up current of CS		V <sub>CS</sub> = 0V	2		50	μA
<b>Logic Output (DO)</b>						
Output low level					0.5	V
Output high level			V <sub>VCC</sub> - 0.7V			V
Leakage current (tri-state)		0V < V <sub>DO</sub> < V <sub>VCC</sub> , V <sub>CS</sub> = V <sub>VCC</sub>	-10		10	μA
<b>Timing Characteristics</b>						
DO enable after CS falling edge	T <sub>1</sub>	C <sub>DO</sub> = 100pF			200	ns
DO disable after CS rising edge	T <sub>2</sub>	C <sub>DO</sub> = 100pF			200	ns
DO falling/rising time		C <sub>DO</sub> = 100pF			100	ns
DO valid time	T <sub>10</sub>	C <sub>DO</sub> = 100pF			200	ns
CS set-up time (high to low)	T <sub>4</sub>		150			ns
CS set-up time (low to high)	T <sub>8</sub>		150			ns
CS high time	T <sub>9</sub>	Bit14 (SCT) = high	0.75			ms
		Bit14 (SCT) = low	0.3			ms
CLK high time	T <sub>5</sub>		150			ns
CLK low time	T <sub>6</sub>		150			ns
CLK period time			333			ns
CLK set-up time (high to low)	T <sub>7</sub>		150			ns
CLK set-up time (low to high)	T <sub>3</sub>		150			ns
DI set-up time	T <sub>11</sub>		26			ns
DI hold time	T <sub>12</sub>		26			ns

**Notes:**

- 6) Guaranteed by characterization. Not tested in production.
- 7) Not subject to production test, specified by design.

**SERIAL INTERFACE TIMING DIAGRAMS**

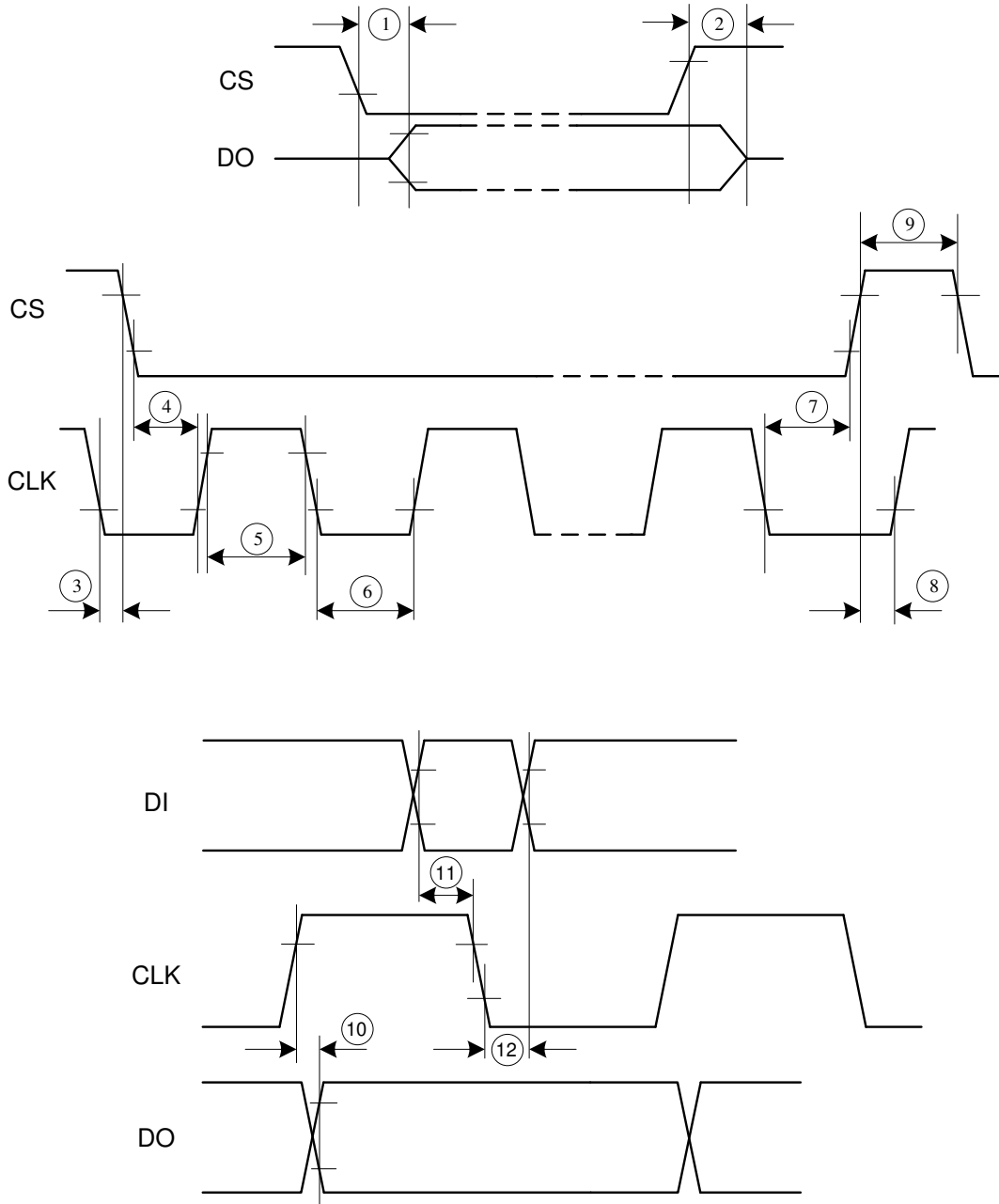

Inputs DI, CLK, CS: High Level = 0.7 x Vcc, Low Level = 0.3 x Vcc  
 Output DO: High Level = 0.8 x Vcc, Low Level = 0.2 x Vcc



**TYPICAL PERFORMANCE CHARACTERISTICS**

$V_{VS} = 13V$ ,  $V_{VCC} = 5V$ ,  $T_A = 25^\circ C$ , unless otherwise noted.

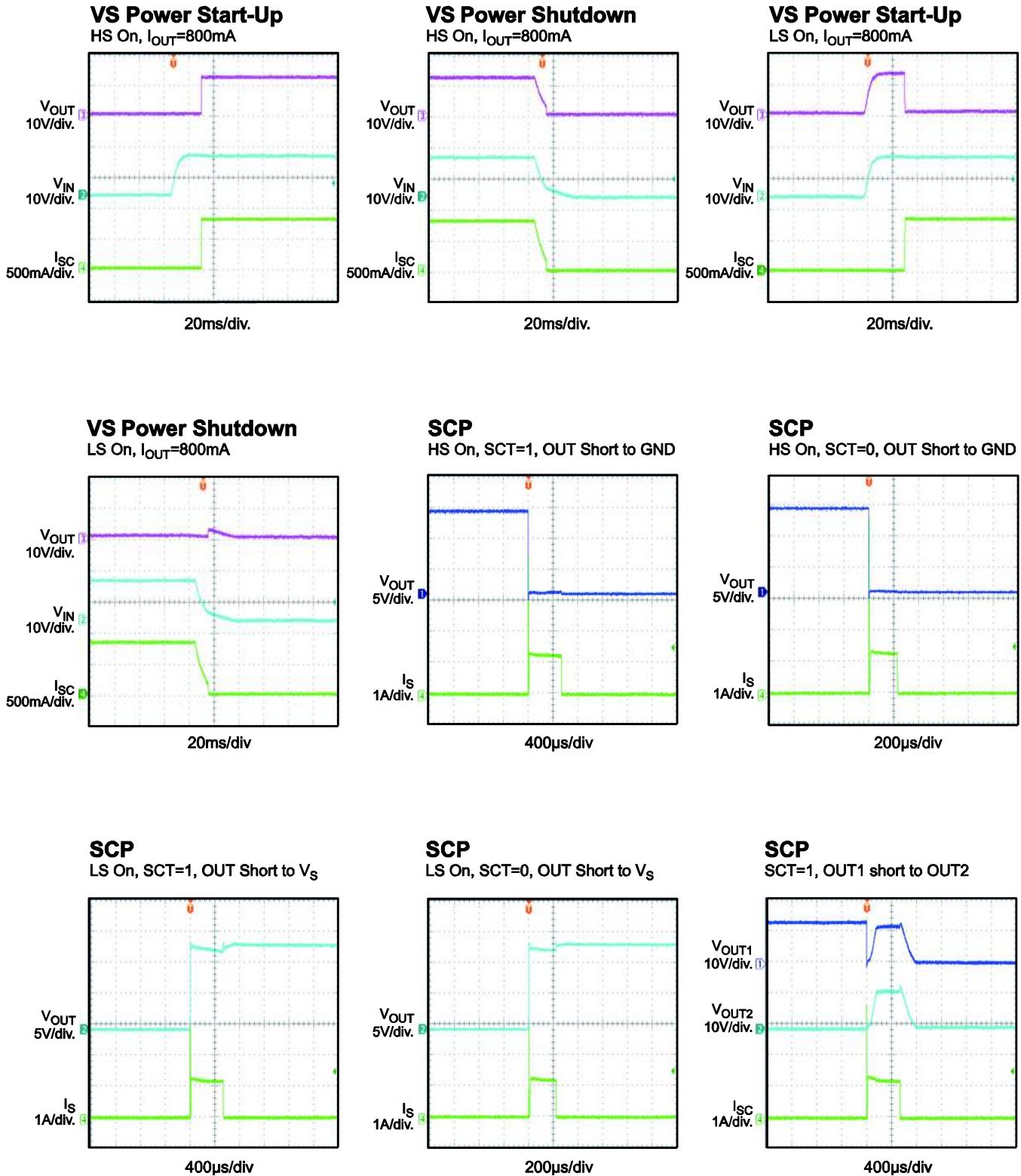

**TYPICAL PERFORMANCE CHARACTERISTICS (continued)**

$V_{VS} = 13V$ ,  $V_{VCC} = 5V$ ,  $T_A = 25^\circ C$ , unless otherwise noted.

**SCP**

SCT=0, OUT1 short to OUT2

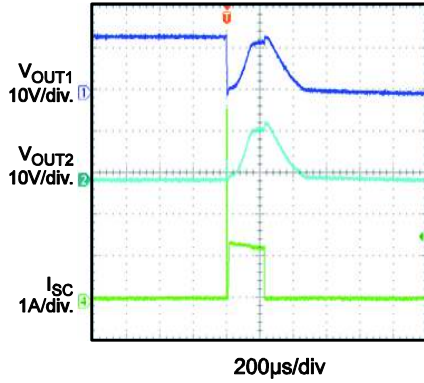

**Output Delay Time**

HS ON

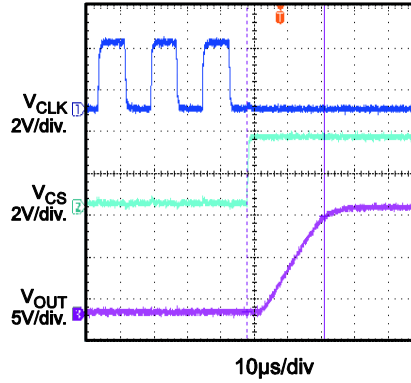

**Output Delay Time**

HS OFF

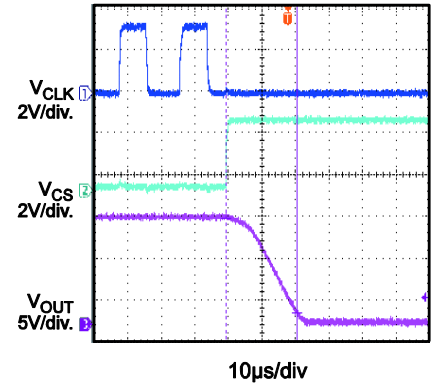

**Output Delay Time**

LS ON

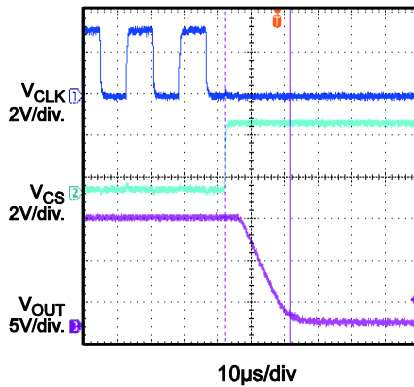

**Output Delay Time**

LS OFF

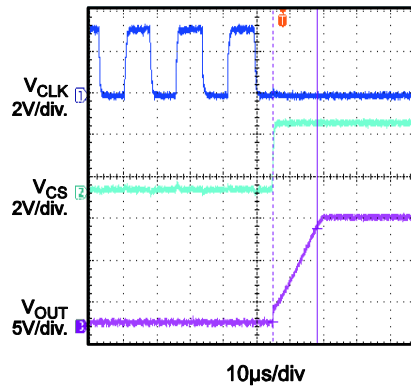

**BLOCK DIAGRAM**

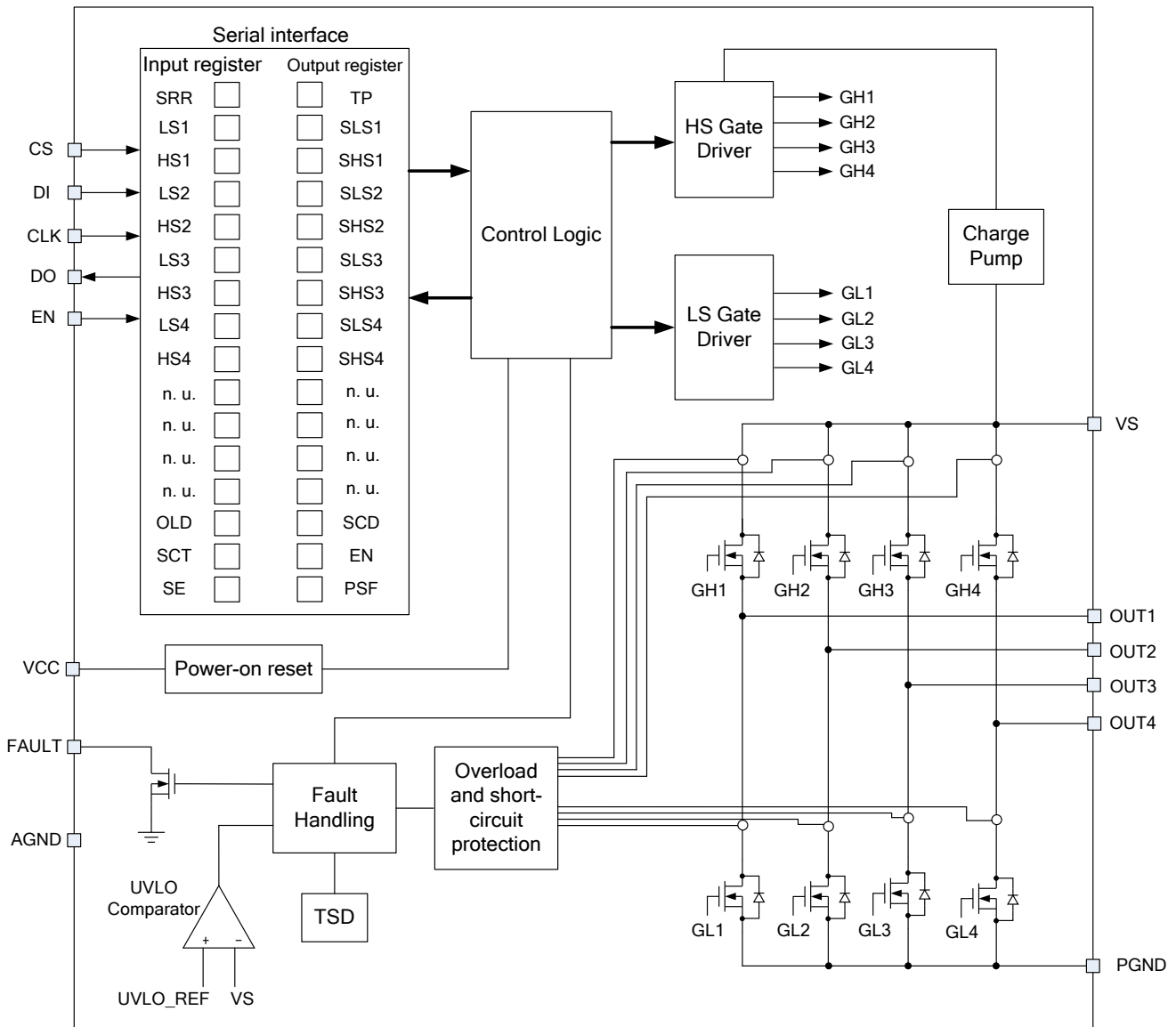

**Figure 1: Functional Block Diagram**

## OPERATION

The MPQ6524 is a four-half-bridge motor driver that can drive up to four different loads with separate controls for high-side or low-side MOSFETs from a standard serial data interface.

### Serial Interface

Data transfer starts with the falling edge of the CS signal (see Figure 2). Execution of new input data is enabled on the rising edge of the CS signal. Data must appear at DI

synchronized to CLK and is accepted on the falling edge of the CLK signal. The LSB (bit0, SRR) must be transferred first.

The output data at DO is enabled on the falling edge of CS. The output data changes state with the rising edge of CLK and remains stable until the next rising edge of CLK appears. When CS is high, DO is in a tri-state condition. LSB (bit[0], TP) is transferred first.

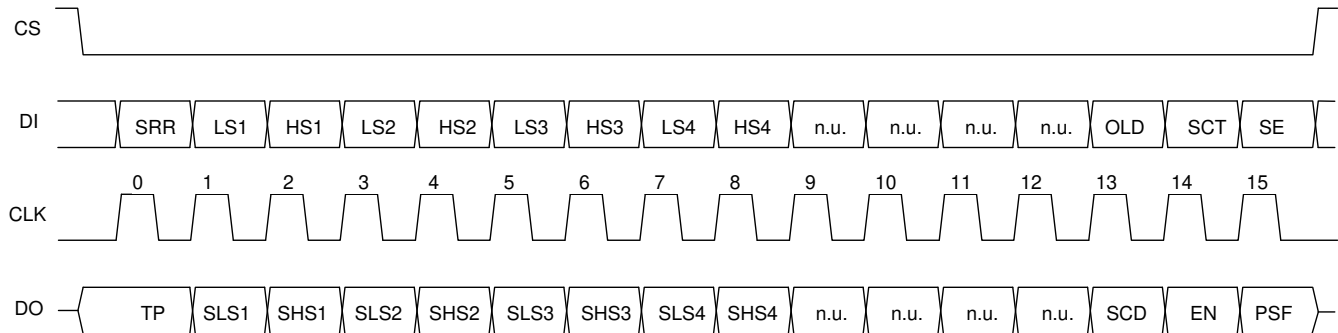

**Figure 2: Data Transfer**

**Table 1: Input Data Protocol**

Bit	Input Register	Function
0	SRR	Status register reset (high = reset. The bits PSF, SCD and over-temperature shutdown in the output data register are set to low).
1	LS1	Controls output LS1 (high = switch output LS1 on).
2	HS1	Controls output HS1 (high = switch output HS1 on).
3	LS2	Controls output LS2 (high = switch output LS2 on).
4	HS2	Controls output HS2 (high = switch output HS2 on).
5	LS3	Controls output LS3 (high = switch output LS3 on).
6	HS3	Controls output HS3 (high = switch output HS3 on).
7	LS4	Controls output LS4 (high = switch output LS4 on).
8	HS4	Controls output HS4 (high = switch output HS4 on).
9	n.u.	Not used.
10	n.u.	Not used.
11	n.u.	Not used.
12	n.u.	Not used.
13	OLD	Open-load detection (low = on).
14	SCT	Programmable time delay for short circuit (shutdown delay high/low = 12ms/1.5ms).
15	SE	Software enable. Low = standby, high = normal operation (data transfer is not affected by the standby function because the digital part is still powered).

**Table 2: Output Data Protocol**

Bit	Input Register	Function
0	TP	Temperature pre-warning: high = warning (over-temperature shutdown see remark below).
1	Status LS1	Normal operation: high = output is on, low = output is off. Open-load detection: high = open load, low = no open load (the correct load condition is detected if the corresponding output is switched off).
2	Status HS1	Normal operation: high = output is on, low = output is off. Open-load detection: high = open load, low = no open load (the correct load condition is detected if the corresponding output is switched off).
3	Status LS2	See LS1.
4	Status HS2	See HS1.
5	Status LS3	See LS1.
6	Status HS3	See HS1.
7	Status LS4	See LS1.
8	Status HS4	See HS1.
9	n.u.	Not used.
10	n.u.	Not used.
11	n.u.	Not used.
12	n.u.	Not used.
13	SCD	Short circuit detected. Set SCD high when at least one output is switched off by a short-circuit condition.
14	EN	Enable. EN is controlled by software (bit SE in the input register) and hardware enable (EN). Low = standby, high = normal operation.
15	PSF	Power supply fail. Under-voltage at VS detected.

**Note:**

8) Bits 0 to 15 = high: over-temperature shutdown.

**Table 3: Status of the Input Register after Power-On Reset**

Bit15 (SE)	Bit14 (SCT)	Bit13 (OLD)	Bit12	Bit11	Bit10	Bit9	Bit8 (HS4)	Bit7 (LS4)	Bit6 (HS3)	Bit5 (LS3)	Bit4 (HS2)	Bit3 (LS2)	Bit2 (HS1)	Bit1 (LS1)	Bit0 (SRR)
H	H	H	x	x	x	x	L	L	L	L	L	L	L	L	L

### Enable Control (EN)

There are two ways to enable or disable the MPQ6524:

- Controlled by software: set bit SE in the input register. Low = standby, high = normal operation.
- Hardware enable (EN): low = standby, high = normal operation.

In both cases, if the device is disabled, then all output stages are turned off, but the serial interface remains active. The output stages can be activated again by setting the bit SE high (when EN = high) or by switching EN back to high (when SE = high).

### Open-Load Detection

When the open-load detection bit (OLD) is set to low, open-load detection is enabled. In this mode, a pull-down current for each low-side switch is turned on. When an open-load has been detected, the corresponding output bit (LSx or HSx) in the output data register is set to high. Once the open load is removed, the corresponding DO bit is cleared, indicating the end of the open-load event.

Testing the open load of the H-bridge configuration is a two-step process. First, switch off all high-side (HSx/HSy) and low-side (LSx/LSy) drivers. The voltage at both clamps in this condition is pulled down. Next, with both low-side drivers off, switch on one high-side driver (HSx or HSy). Since the DC motor has a relatively low internal resistance, the voltage of the inactive high-side output should be at the same level as the activated high-side output. In the case of an open load, the inactive high-side output register reports a 0 if the active high-side output is 1. Conversely, if the load is connected, the inactive high-side output reports a 1.

### Discharge Circuit

Many typical applications use an inverse-polarity protection diode (see D1 in Figure 3). However, this method involves a certain risk. During inhibit mode, the IC consumes only an extremely low current ( $I_{VS}$ ) (i.e.: 20 $\mu$ A max). Any peaks on the supply voltage charge the blocking capacitor gradually. D1 prevents the capacitor from discharging via the power supply. Due to the extremely small quiescent current, discharging via the IC can also be neglected. This means that during long periods in inhibit mode, the IC's supply voltage could increase continuously until the maximum supply voltage limit of 40V is exceeded, damaging the IC. The device features a discharger circuit that prevents such unwanted effects. If VS exceeds a threshold value of approximately 37V, the blocking capacitor is discharged via an integrated resistor until VS falls below the threshold again.

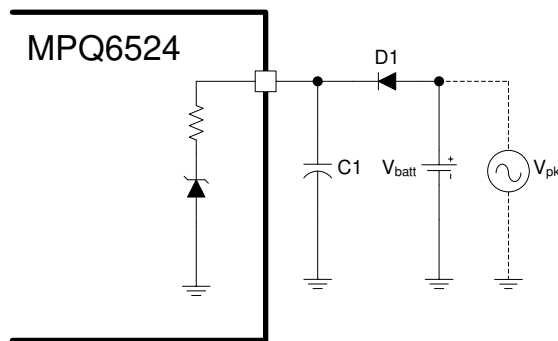

**Figure 3: Functional Principle of the Discharger Circuit**

### Over-Current Protection (OCP)

The MPQ6524 has internal overload and short-circuit protection. The currents in both the high-side and low-side MOSFETs are measured. If the current exceeds the current limit, an internal timer is started. When a permanent over-current shutdown delay time programmed by the short-circuit timer bit (SCT) is reached, the short-circuit detection bit (SCD) is set, and the shorted output is disabled. By writing a high to the SRR bit in the input register, the SCD bit is reset, and the disabled outputs are enabled.

### **Thermal Shutdown and Pre-Warning**

Thermal monitoring is also integrated into the MPQ6524. If the junction temperature rises above the thermal pre-warning threshold, the temperature pre-warning bit (TP) in the output register is set. When the temperature falls below the thermal pre-warning threshold, the bit TP is reset. The bit TP can be read without transferring a complete 16-bit data word. When CS = high to low, the state of TP appears at DO. After the microcontroller has read this information, CS is set high, and the data transfer is interrupted without affecting the state of the input and output registers.

If the junction temperature rises above the thermal shutdown threshold, all switches turn off, and all bits in the output register are set high. Operation resumes immediately when the junction temperature has fallen below the thermal shutdown threshold and when a high has been written to the SRR bit in the input register.

The thermal pre-warning and shutdown threshold have hysteresis.

Note that bit0 to 15 = high indicates an over-temperature shutdown.

### **Power-Supply Fail**

If at any time the voltage on VS falls below the under-voltage lockout (UVLO) threshold voltage, an internal timer is started. The power supply fail bit (PSF) in the output register is set, and all outputs are disabled when a permanent UVLO delay time is reached.

Operation resumes immediately when VS rises above the UVLO threshold. The PSF bit remains high until it is reset by the SRR bit in the input register.

### **Fault Output**

The MPQ6524 includes an open-drain, active-low, fault indicator output (FAULT). A fault is indicated if the current limit is tripped or thermal shutdown is tripped. A fault on any channel causes FAULT to be pulled low. The FAULT value is maintained until the fault condition is removed and normal operation resumes. Do not apply more than 6V to FAULT.



**PACKAGE INFORMATION**

**QFN-24 (4mmx4mm)  
Wettable Flank**

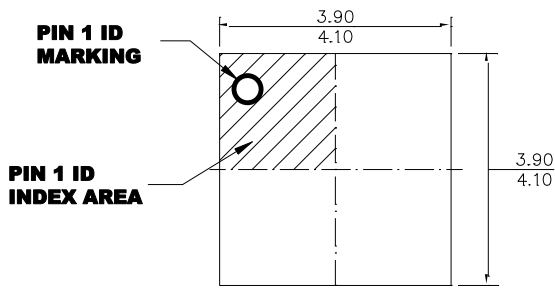

**TOP VIEW**

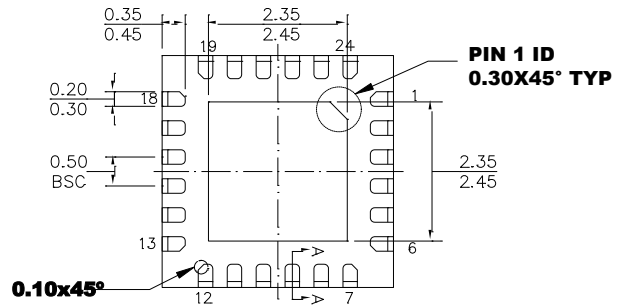

**BOTTOM VIEW**

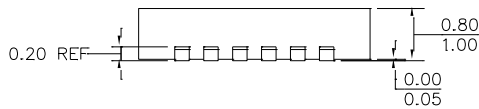

**SIDE VIEW**

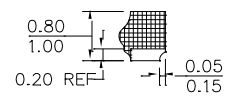

**SECTION A-A**

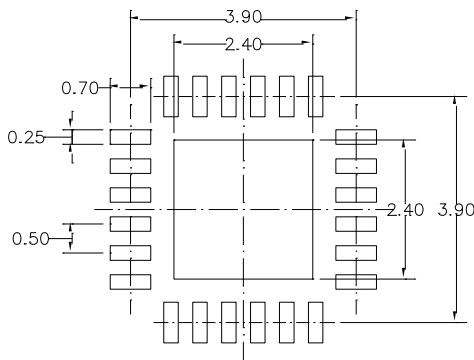

**RECOMMENDED LAND PATTERN**

**NOTE:**

- 1) THE LEAD SIDE IS WETTABLE.
- 2) ALL DIMENSIONS ARE IN MILLIMETERS.
- 3) LEAD COPLANARITY SHALL BE 0.08 MILLIMETERS MAX.
- 4) JEDEC REFERENCE IS MO-220.
- 5) DRAWING IS NOT TO SCALE.



**REVISION HISTORY**

Revision #	Revision Date	Description	Pages Updated
1.0	10/14/2018	Initial Release	-
1.01	1/12/2022	Updated the serial interface clock frequency bullet point in the Features section from “5V Compatible” to “3.3V and 5V Compatible”	1
		Changed “-Z” to “-Z”	3
		Updated the recommended logic supply voltage range from “4.75V to 5.25V” to “3.15V to 5.25V”	4
		Added notice at bottom of page	17
		Grammar and formatting updates	All

**Notice:** The information in this document is subject to change without notice. Users should warrant and guarantee that third-party Intellectual Property rights are not infringed upon when integrating MPS products into any application. MPS will not assume any legal responsibility for any said applications.