

ITEM	COMPONENT	SUPPLIER	DESCRIPTION	QUANTITY	NOTE
▽	99026-0036	MOLEX	SOCKT RIBBON CABLE 28 AWG 127MM PITCH	1	2,3,4
▽	22220024	MOLEX	127MM 0F-50 RECEPTACLE	2	1,3
▽	90170-0050	MOLEX	STRAIN RELIEF FOR SOCKT CONNECTOR	2	3
▽	90848-0255	MOLEX	WRAP AROUND LABEL	1	5

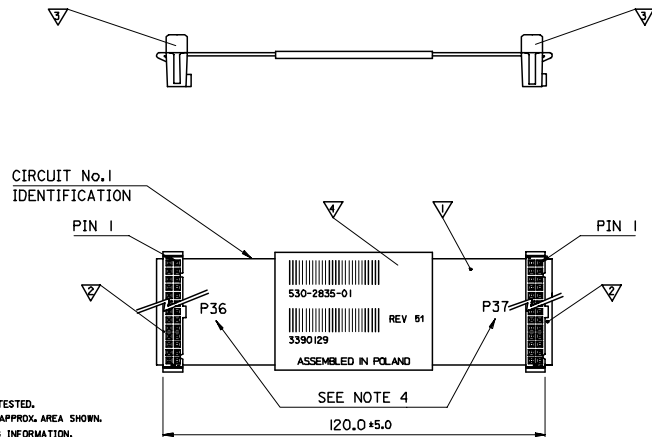

- NOTES:
- SEE PRODUCT SPECIFICATION PS-99020-0015.
 - SEE CABLE SPECIFICATION ES-99027-0006.
 - ALL HARNESSSES TO BE 100% ELECTRICALLY TESTED.
 - REFERENCE DESIGNATION (I.E. *P36*, *P37*) IN APPROX. AREA SHOWN.
 - LABEL TO BE PRINTED WITH THE FOLLOWING INFORMATION:
THE TOP LINE WILL COMPRISE THE HARNESS NUMBER IN BARCODE FORM.
THE SECOND LINE WILL BE COMPRISED OF THE HARNESS NUMBER IN HUMAN READABLE FORM. (530-****-**))
THE THIRD LINE WILL BE COMPRISED OF THE VENDOR CODE, DATE CODE, IN BARCODE FORM.
REV 51 TO BE PRINTED BESIDE BARCODE.
THE FOURTH LINE WILL BE COMPRISED VENDOR CODE, DATE CODE, IN HUMAN READABLE FORM.
VENDOR CODE/REV/REV. (3390129), ASSEMBLED IN POLAND
 - PACKAGING, PARTS PACKED LOOSELY, 5 PER BAG.
 - ALL MATERIALS USED IN THE CONSTRUCTION OF THIS COMPONENT/ASSEMBLY (INCLUDING RAW STOCK, COATINGS, HARDWARE, GASKETING, ETC.) SHALL COMPLY WITH THE LATEST REVISION OF SUN ROHS-COMPLIANT SPECIFICATION SH-1742-10X.

ADDED NOTE 7 EC NO.: E2006-0851 DRAWN: KRUSZAKIN 2006/03/22 CHKCD: WARMS 2006/03/22 APPR: MIWAS/ECZKO 2006/03/23	QUALITY SYMBOLS ▽=0 ▽=0	GENERAL TOLERANCES (UNLESS SPECIFIED) <table border="1"> <thead> <tr> <th></th> <th>mm</th> <th>INCH</th> </tr> </thead> <tbody> <tr> <td>4 PLACES</td> <td>±---</td> <td>±---</td> </tr> <tr> <td>3 PLACES</td> <td>±---</td> <td>±---</td> </tr> <tr> <td>2 PLACES</td> <td>±---</td> <td>±---</td> </tr> <tr> <td>1 PLACE</td> <td>±---</td> <td>±---</td> </tr> <tr> <td colspan="2">ANGULAR</td> <td>±---</td> </tr> </tbody> </table>		mm	INCH	4 PLACES	±---	±---	3 PLACES	±---	±---	2 PLACES	±---	±---	1 PLACE	±---	±---	ANGULAR		±---	DIMENSION STYLE MM ONLY	SCALE ---	DESIGN UNITS METRIC	THIRD ANGLE PROJECTION
		mm	INCH																					
4 PLACES	±---	±---																						
3 PLACES	±---	±---																						
2 PLACES	±---	±---																						
1 PLACE	±---	±---																						
ANGULAR		±---																						
DRAWN BY: BENR IGH T CHECKED BY: DRYAN APPROVED BY: MWILHITE		DATE: 2000/11/23 DATE: 2000/11/23 DATE: 2000/11/23	TITLE 50CKT RIBBON CABLE																					
MATERIAL NO. 92301-0197		DOCUMENT NO. SD-92301-362		SHEET NO. 1 OF 1																				
DRAFT WHERE APPLICABLE MUST REMAIN WITHIN DIMENSIONS																								
THIS DRAWING CONTAINS INFORMATION THAT IS PROPRIETARY TO MOLEX INCORPORATED AND SHOULD NOT BE USED WITHOUT WRITTEN PERMISSION																								

SHT. 1 OF 1				MRI- SD-92301-362		
MODIFICATION RECORD INDEX						
ECN	ISS.	DATE	INIT.	SHTS. AFFECTED	DESCRIPTION OF MOD.	
E2001-0606	A	00.11.23	BE	1	ORIGINAL RELEASE	
E2006-0851	B	2006/03/16	JK	1	ADDED NOTE 7	
MOLEX EUROPE			REVISE ONLY ON CAD SYSTEM			
THIS DRAWING CONTAINS INFORMATION THAT IS PROPRIETARY TO MOLEX INC. & SHOULD NOT BE USED WITHOUT WRITTEN PERMISSION				CADCAM FILENAME MFO028		ISSUE A