

DATE	REV.	ECN	APP'D BY
4-21-17	A1	10984	ADB
4-27-17	A2	10989	ADB
12-22-17	A3	11180	ADB
9-11-18	B0	11289	ADB
05-24-22	B1	11988	GWL

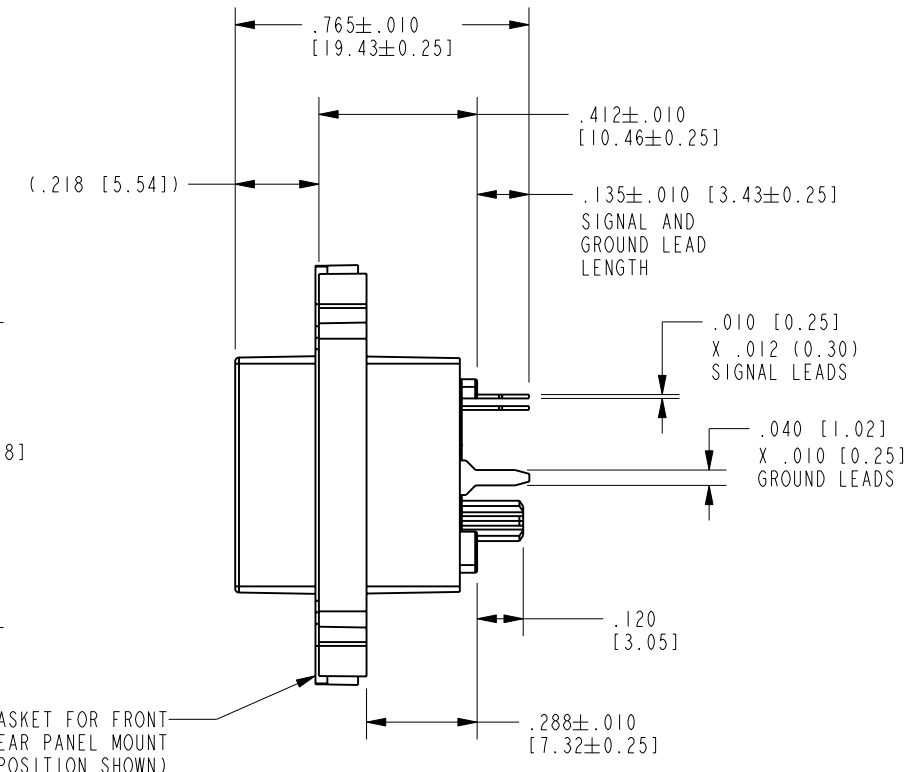

- NOTES:
- CONNECTOR MATERIALS:
HOUSING/INSERT: THERMOPLASTIC UL94 V-0
SHIELD: ZINC DIE-CAST ALLOY
SHIELD PLATING: TIN OVER COPPER
CONTACTS: COPPER ALLOY
CONTACT PLATING: SEE TABLE BELOW
GASKET: SILICONE RUBBER
SILICONE SEALING COMPOUND IN REAR OF JACK
 - PRODUCT INTENDED FOR CATEGORY 6 APPLICATIONS.
 - DIMENSIONS AND TOLERANCES COMPLY WITH TIA-1096 STANDARD.
 - REFERENCE PRODUCT SPECIFICATION PR042-01.
 - ENVIRONMENTAL PERFORMANCE PER IEC 60529 CODE IP67, FOR CONNECTOR AND PANEL INTERFACE. REFER TO INSTRUCTION SHEET MN600001 FOR INSTALLATION GUIDELINES.
- △ PRODUCT MARKED WITH COMPANY LOGO, PART NUMBER, AND MANUFACTURING DATE / LOCATION IN AREAS AS SHOWN.

50 MICRO-INCHES [1.27um] AU	SS-60400-010
CONTACT PLATING IN MATING AREA	PART NUMBER

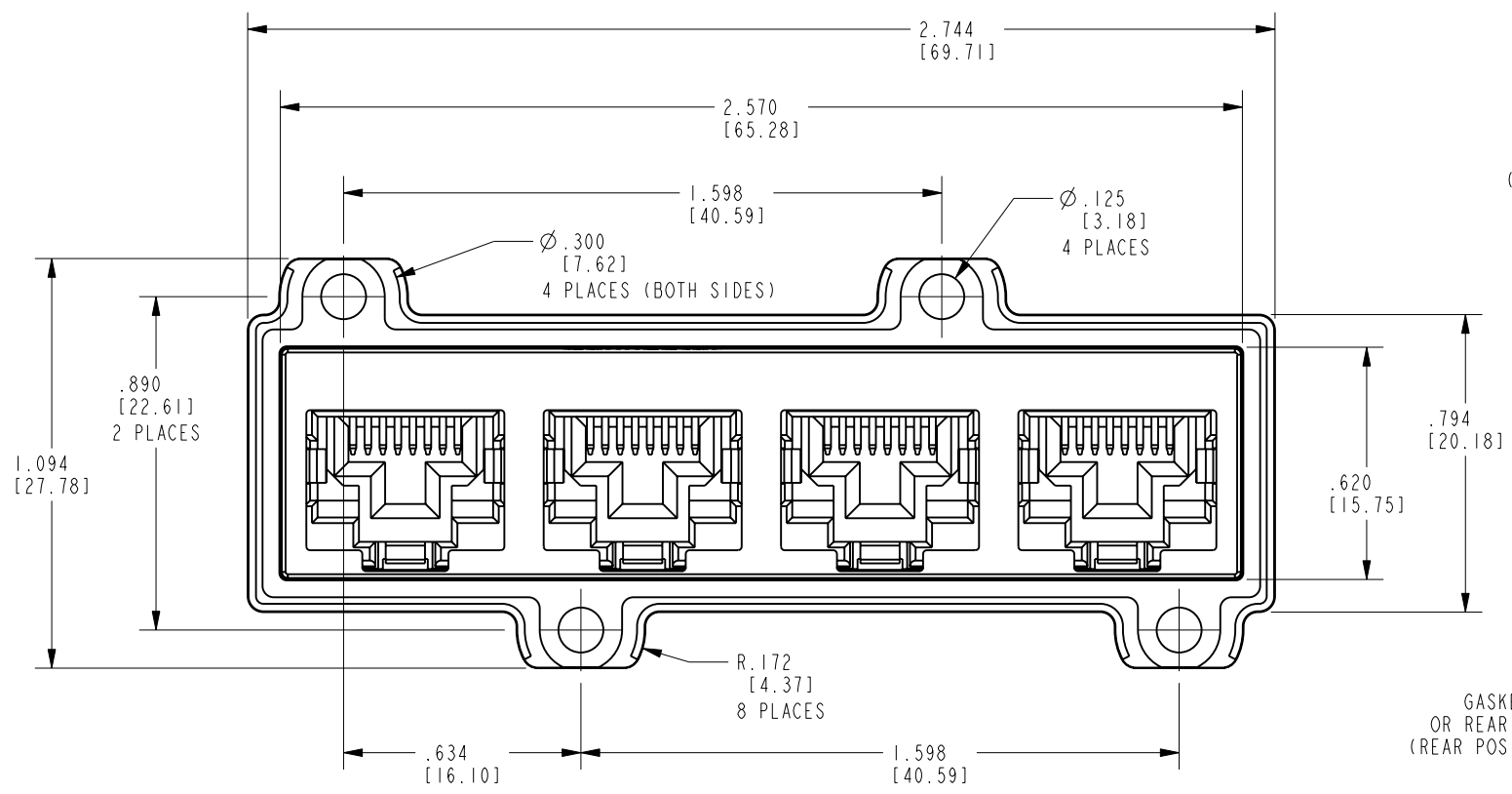
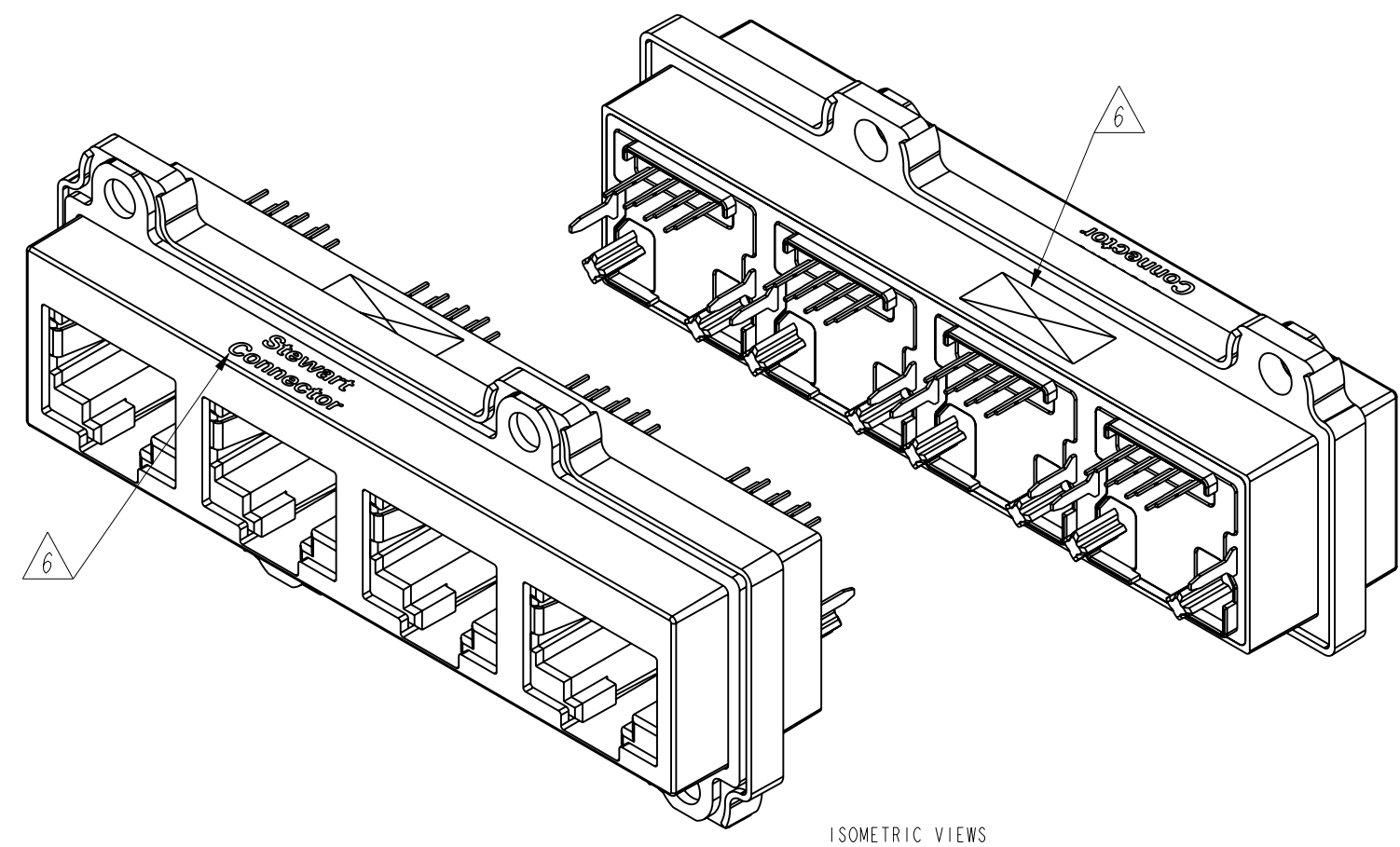

ISOMETRIC VIEWS



THIRD ANGLE PROJECTION	
DO NOT SCALE DRAWING DRAWING IS SUBJECT TO CHANGE WITHOUT NOTICE	TITLE: VERTICAL CAT 6 SEALJACK, 4 PORT, WITH THROUGH HOLE MOUNTING
DIMENSIONS: INCHES [METRIC]	THIS DRAWING AND THE SUBJECT MATTER SHOWN THEREON ARE CONFIDENTIAL AND THE PROPRIETARY PROPERTY OF STEWART CONNECTOR AND SHALL NOT BE REPRODUCED, COPIED, OR USED IN ANY MANNER WITHOUT PRIOR WRITTEN CONSENT OF STEWART CONNECTOR. ONE OR MORE U.S. PATENTS MAY APPLY TO THIS PRODUCT. FOR DETAILS, PLEASE VISIT: HTTP://BELFUSE.COM/STEWART/STEWART_PATENTS/
UNLESS OTHERWISE SPECIFIED TOLERANCES ARE ±.005 [0.13] ANGLES ARE ±1°	DRN BY: ADB DATE 10-22-15
SHEET NO. 1 OF 3	APPD BY: DHG DATE 10-23-15
	DWG. NO. CT600160 REV. B1

11118 Susquehanna Trail South
Glen Rock, PA 17327-9199
(717) 235-7512
<http://www.stewartconnector.com>

B

B

A

A

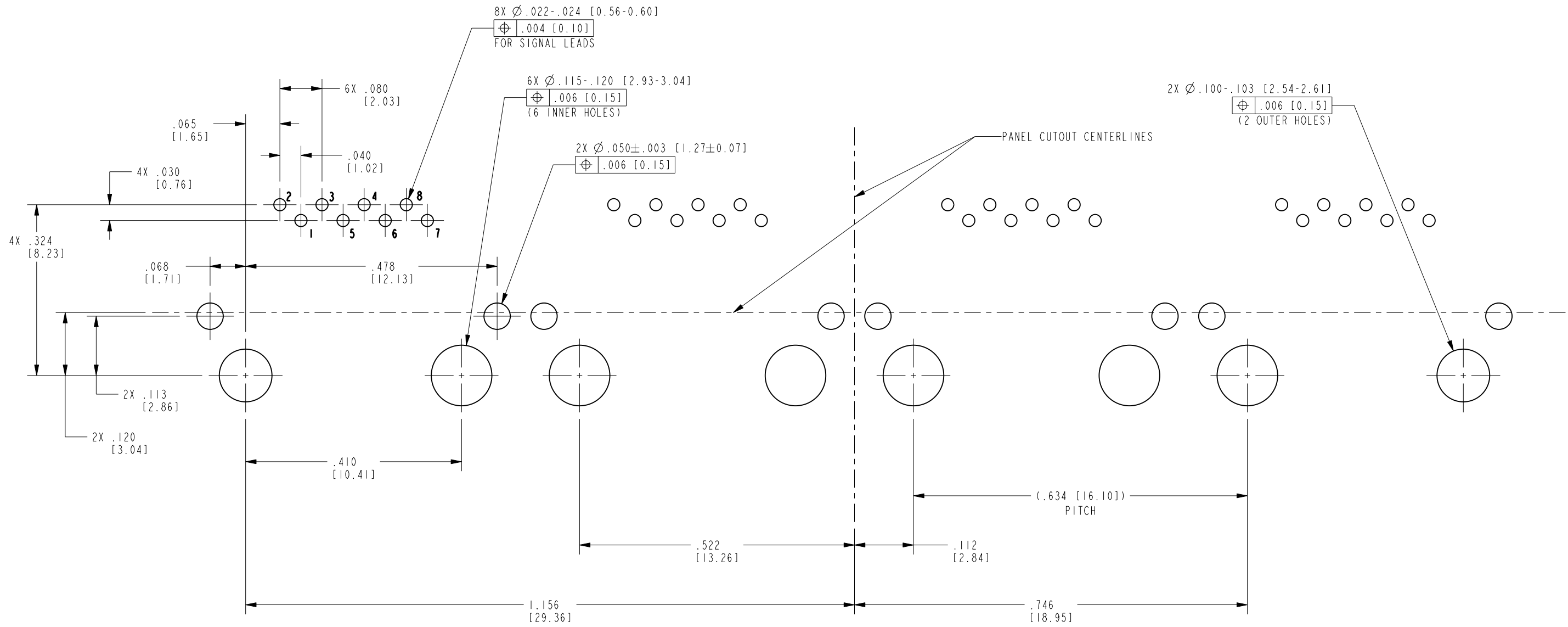

RECOMMENDED P.C.B. LAYOUT (COMPONENT SIDE OF BOARD)
 SCALE 5.000
 ALL CENTERLINE DIMENSIONS ARE BASIC (PATTERN REPEATS 4 TIMES AS SHOWN)

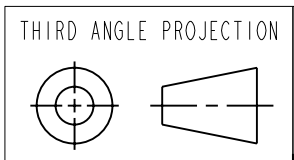

11118 Susquehanna Trail South
 Glen Rock, PA 17327-9199
 (717) 235-7512
<http://www.stewartconnector.com>

DO NOT SCALE DRAWING
 DRAWING IS SUBJECT TO
 CHANGE WITHOUT NOTICE

TITLE: VERTICAL CAT 6 SEALJACK, 4 PORT,
 WITH THROUGH HOLE MOUNTING

DIMENSIONS: INCHES [METRIC]
 UNLESS OTHERWISE SPECIFIED
 TOLERANCES ARE \pm .005 [0.13]
 ANGLES ARE \pm 1°

THIS DRAWING AND THE SUBJECT MATTER SHOWN THEREON
 ARE CONFIDENTIAL AND THE PROPRIETARY PROPERTY OF
 STEWART CONNECTOR AND SHALL NOT BE REPRODUCED,
 COPIED, OR USED IN ANY MANNER WITHOUT PRIOR WRITTEN
 CONSENT OF STEWART CONNECTOR. ONE OR MORE U.S. PATENTS
 MAY APPLY TO THIS PRODUCT. FOR DETAILS, PLEASE
 VISIT: [HTTP://BELFUSE.COM/STEWART/STEWART_PATENTS/](http://BELFUSE.COM/STEWART/STEWART_PATENTS/)

DRN BY:	ADB	DATE	10-22-15
APPD BY:	DHG	DATE	10-23-15
DWG. NO.	CT600160	REV.	B1

SHEET NO.
 2 OF 3



B

B

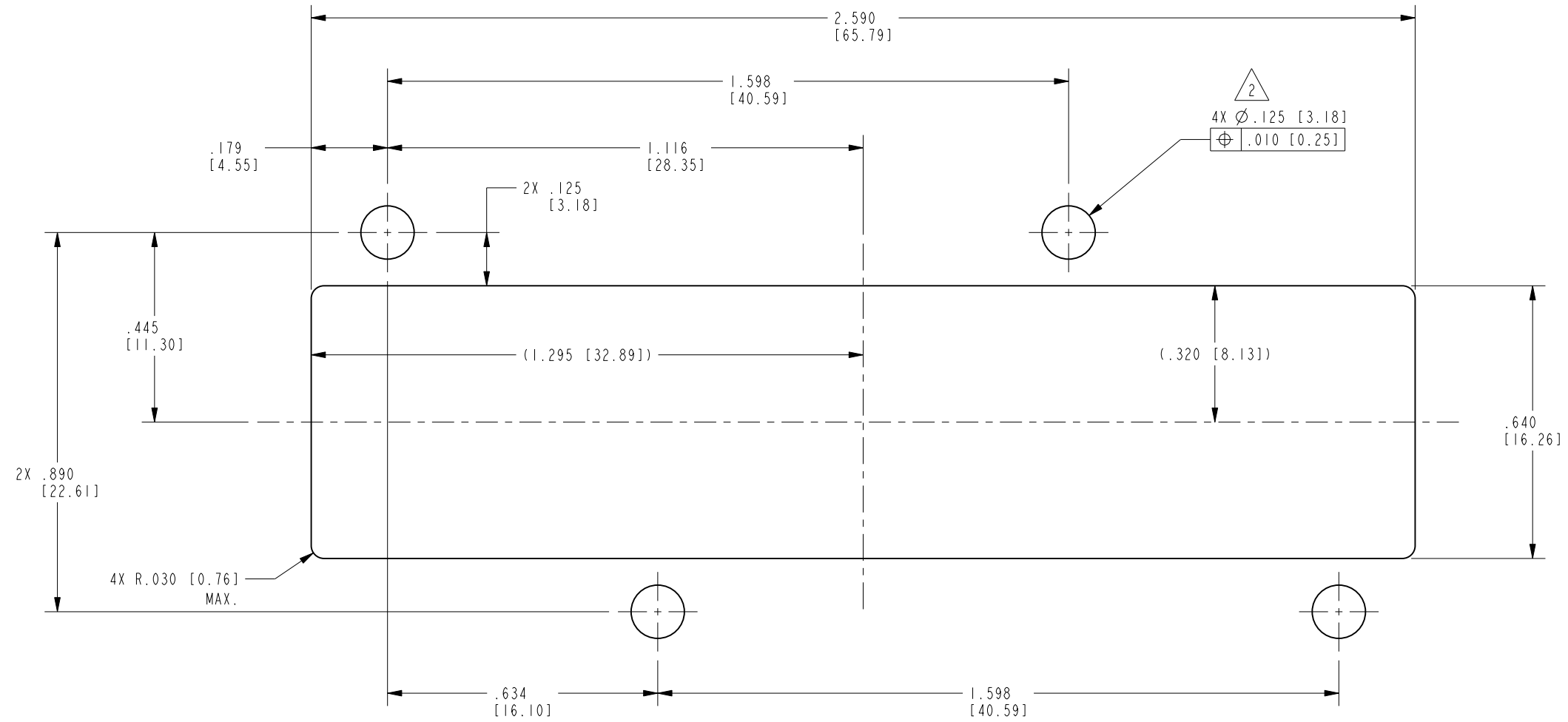

RECOMMENDED PANEL LAYOUT (FRONT OF PANEL)
SCALE 3.000
ALL CENTERLINE DIMENSIONS ARE BASIC

A

A

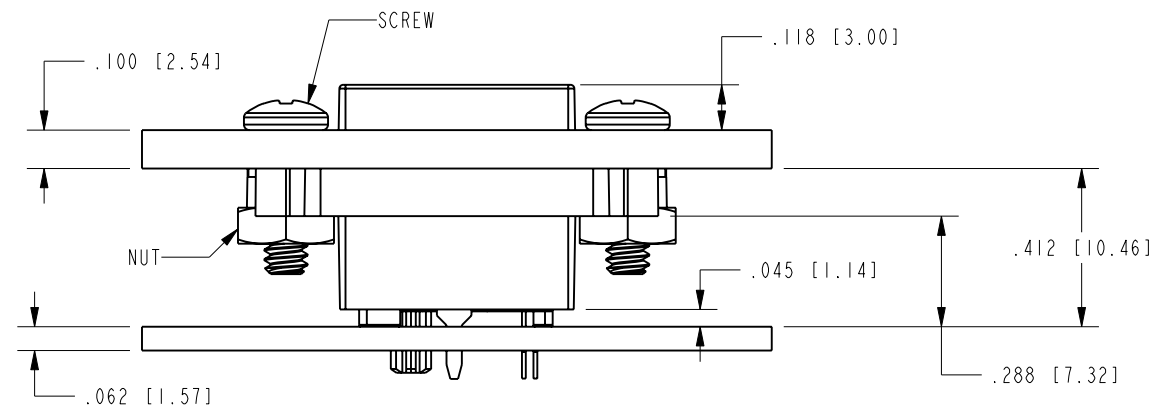

SIDE VIEW - SHOWN WITH .100" PANEL AND .062" BOARD FOR REFERENCE ONLY
TYPICAL FASTENERS SHOWN (#4-40 X 3/8 LONG PAN HEAD SCREW WITH HEX NUT ON REAR OF DIECAST)
SCALE 2.000
(SHOWN WITH GASKET IN FULLY COMPRESSED STATE)

NOTES:

- IF MOUNTING MULTIPLE CONNECTORS SIDE-BY-SIDE, THE SUGGESTED SPACING (PITCH) IS AT LEAST 2.8 INCHES [71 mm]. CONNECTORS CAN BE NESTED VERTICALLY ON THE SAME CENTERLINE AXIS, WHICH REQUIRES A VERTICAL PITCH OF .98 INCHES [25 mm]. THIS PITCH MAY NEED INCREASED DEPENDING ON THE FASTENERS USED FOR MOUNTING.
- INDICATED HOLES ARE CLEARANCE FOR THROUGH FASTENERS. PANEL MAY USE THREADED HOLES - SEE INSTRUCTION SHEET MN600001 FOR MORE DETAILS ON MOUNTING OPTIONS.

THIRD ANGLE PROJECTION

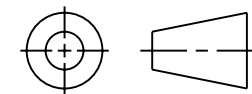

11118 Susquehanna Trail South
Glen Rock, PA 17327-9199
(717) 235-7512

<http://www.stewartconnector.com>

DO NOT SCALE DRAWING
DRAWING IS SUBJECT TO
CHANGE WITHOUT NOTICE

TITLE: VERTICAL CAT 6 SEALJACK, 4 PORT,
WITH THROUGH HOLE MOUNTING

DIMENSIONS: INCHES [METRIC]
UNLESS OTHERWISE SPECIFIED
TOLERANCES ARE ±.005 [0.13]
ANGLES ARE ±1°

THIS DRAWING AND THE SUBJECT MATTER SHOWN THEREON ARE CONFIDENTIAL AND THE PROPRIETARY PROPERTY OF STEWART CONNECTOR AND SHALL NOT BE REPRODUCED, COPIED, OR USED IN ANY MANNER WITHOUT PRIOR WRITTEN CONSENT OF STEWART CONNECTOR. ONE OR MORE U.S. PATENTS MAY APPLY TO THIS PRODUCT. FOR DETAILS, PLEASE VISIT: [HTTP://BELFUSE.COM/STEWART/STEWART_PATENTS/](http://BELFUSE.COM/STEWART/STEWART_PATENTS/)

DRN BY: ADB DATE 10-22-15

APPD BY: DHG DATE 10-23-15

DWG. NO. CT600160 REV. B1



RoHS