

MC9S12E256

Data Sheet

HCS12
Microcontrollers

MC9S12E256
Rev. 1.10
07/2012

freescale.com

MC9S12E256 Data Sheet

MC9S12E256
Rev. 1.10
07/2012

To provide the most up-to-date information, the revision of our documents on the World Wide Web will be the most current. Your printed copy may be an earlier revision. To verify you have the latest information available, refer to:

<http://freescale.com/>

The following revision history table summarizes changes contained in this document.

Revision History

Date	Revision Level	Description
November 10, 2005	1.07	New Data Sheet
January 18, 2006	1.08	Table A-4. Operating Conditions — Updated minimum value for I/O, Regulator and Analog Supply Voltage
		Table A-9. Voltage Regulator Electrical Parameters — Updated minimum value for Low Voltage Interrupt for both Assert Level and Deassert Level.
June 1, 2006	1.09	Table A-22. 5V ATD Conversion Performance - Updated minimum and maximum limit for 10-Bit Integral Nonlinearity
July 6, 2012	1.10	Update the TIM block guide Fix typo on the A.7.1 DAC Operating Characteristics

Freescale™ and the Freescale logo are trademarks of Freescale Semiconductor, Inc. This product incorporates SuperFlash® technology licensed from SST.

© Freescale Semiconductor, Inc., 2006. All rights reserved.

List of Chapters

Chapter 1	MC9S12E256 Device Overview (MC9S12E256DGV1)	21
Chapter 2	256 Kbyte Flash Module (S12FTS256K2V1).	81
Chapter 3	Port Integration Module (PIM9E256V1) Block Description . .	121
Chapter 4	Clocks and Reset Generator (CRGV4) Block Description . .	167
Chapter 5	Oscillator (OSCV2) Block Description	203
Chapter 6	Analog-to-Digital Converter (ATD10B16CV4) Block Description	207
Chapter 7	Digital-to-Analog Converter (DAC8B1CV1) Block Description .	241
Chapter 8	Serial Communication Interface (SCIV4) Block Description	249
Chapter 9	Serial Peripheral Interface (SPIV3) Block Description	283
Chapter 10	Inter-Integrated Circuit (IICV2) Block Description.	305
Chapter 11	Pulse Width Modulator with Fault Protection(PMF15B6C)Module	329
Chapter 12	Pulse-Width Modulator (PWM8B6CV1) Block Description . .	385
Chapter 13	Timer (S12TIM16B4CV1) Block Description.	421
Chapter 14	Dual Output Voltage Regulator (VREG3V3V2) Block Description	445
Chapter 15	Background Debug Module (BDMV4) Block Description . . .	453
Chapter 16	Debug Module (DBGV1) Block Description	479
Chapter 17	Interrupt (INTV1) Block Description	513
Chapter 18	Multiplexed External Bus Interface (MEBIV3)	521
Chapter 19	Module Mapping Control (MMCV4) Block Description	551
Appendix A	Electrical Characteristics.	571
Appendix B	Ordering Information and Mechanical Drawings.	606

Chapter 1

MC9S12E256 Device Overview (MC9S12E256DGV1)

1.1	Introduction	21
1.1.1	Features	21
1.1.2	Modes of Operation	23
1.1.3	Block Diagram	24
1.2	Device Memory Map	25
1.2.1	Detailed Register Map	27
1.2.2	Part ID Assignments	56
1.3	Signal Description	57
1.3.1	Device Pinout	57
1.3.2	Signal Properties Summary	59
1.4	Detailed Signal Descriptions	61
1.4.1	EXTAL, XTAL — Oscillator Pins	61
1.4.2	RESET — External Reset Pin	61
1.4.3	TEST — Test Pin	61
1.4.4	XFC — PLL Loop Filter Pin	61
1.4.5	BKGD / TAGHI / MODC — Background Debug, Tag High & Mode Pin	61
1.4.6	PA[7:0] / ADDR[15:8] / DATA[15:8] — Port A I/O Pins	61
1.4.7	PB[7:0] / ADDR[7:0] / DATA[7:0] — Port B I/O Pins	61
1.4.8	PE7 / NOACC / XCLKS — Port E I/O Pin 7	62
1.4.9	PE6 / MODB / IPIPE1 — Port E I/O Pin 6	62
1.4.10	PE5 / MODA / IPIPE0 — Port E I/O Pin 5	63
1.4.11	PE4 / ECLK — Port E I/O Pin 4 / E-Clock Output	63
1.4.12	PE3 / LSTRB / TAGLO — Port E I/O Pin 3 / Low-Byte Strobe (LSTRB)	63
1.4.13	PE2 / R/W — Port E I/O Pin 2 / Read/Write	63
1.4.14	PE1 / IRQ — Port E input Pin 1 / Maskable Interrupt Pin	63
1.4.15	PE0 / XIRQ — Port E input Pin 0 / Non Maskable Interrupt Pin	64
1.4.16	PK7 / ECS / ROMCTL — Port K I/O Pin 7	64
1.4.17	PK6 / XCS — Port K I/O Pin 6	64
1.4.18	PK[5:0] / XADDR[19:14] — Port K I/O Pins [5:0]	64
1.4.19	PAD[15:0] / AN[15:0] / KWAD[15:0] — Port AD I/O Pins [15:0]	65
1.4.20	PM7 / SCL — Port M I/O Pin 7	65
1.4.21	PM6 / SDA — Port M I/O Pin 6	65
1.4.22	PM5 / TXD2 — Port M I/O Pin 5	65
1.4.23	PM4 / RXD2 — Port M I/O Pin 4	65
1.4.24	PM3 — Port M I/O Pin 3	65
1.4.25	PM1 / DAO1 — Port M I/O Pin 1	66
1.4.26	PM0 / DAO2 — Port M I/O Pin 0	66
1.4.27	PP[5:0] / PW0[5:0] — Port P I/O Pins [5:0]	66
1.4.28	PQ[6:4] / IS[2:0] — Port Q I/O Pins [6:4]	66
1.4.29	PQ[3:0] / FAULT[3:0] — Port Q I/O Pins [3:0]	66

Section Number	Title	Page
1.4.30	PS7 / SS — Port S I/O Pin 7	66
1.4.31	PS6 / SCK — Port S I/O Pin 6	67
1.4.32	PS5 / MOSI — Port S I/O Pin 5	67
1.4.33	PS4 / MISO — Port S I/O Pin 4	67
1.4.34	PS3 / TXD1 — Port S I/O Pin 3	67
1.4.35	PS2 / RXD1 — Port S I/O Pin 2	67
1.4.36	PS1 / TXD0 — Port S I/O Pin 1	68
1.4.37	PS0 / RXD0 — Port S I/O Pin 0	68
1.4.38	PT[7:4] / IOC1[7:4]— Port T I/O Pins [7:4]	68
1.4.39	PT[3:0] / IOC0[7:4]— Port T I/O Pins [3:0]	68
1.4.40	PU[7:6] — Port U I/O Pins [7:6]	68
1.4.41	PU[5:4] / PW1[5:4] — Port U I/O Pins [5:4]	68
1.4.42	PU[3:0] / IOC2[7:4]/PW1[3:0] — Port U I/O Pins [3:0]	69
1.4.43	VDDX,VSSX — Power & Ground Pins for I/O Drivers	69
1.4.44	VDDR, VSSR — Power Supply Pins for I/O Drivers & for Internal Voltage Regulator	69
1.4.45	VDD1, VDD2, VSS1, VSS2 — Power Supply Pins for Internal Logic	69
1.4.46	VDDA, VSSA — Power Supply Pins for ATD and VREG	69
1.4.47	VRH, VRL — ATD Reference Voltage Input Pins	69
1.4.48	VDDPLL, VSSPLL — Power Supply Pins for PLL	69
1.5	System Clock Description	71
1.6	Modes of Operation	72
1.6.1	Overview	72
1.6.2	Chip Configuration Summary	72
1.7	Security	73
1.7.1	Securing the Microcontroller	73
1.7.2	Operation of the Secured Microcontroller	73
1.7.3	Unsecuring the Microcontroller	73
1.8	Low Power Modes	74
1.8.1	Stop	74
1.8.2	Pseudo Stop	74
1.8.3	Wait	74
1.8.4	Run	74
1.9	Resets and Interrupts	74
1.9.1	Vectors	74
1.9.2	Resets	76
1.10	Recommended Printed Circuit Board Layout	77

Chapter 2

256 Kbyte Flash Module (S12FTS256K2V1)

2.1	Introduction	81
2.1.1	Glossary	81
2.1.2	Features	82

Section Number	Title	Page
2.1.3	Modes of Operation	82
2.1.4	Block Diagram	82
2.2	External Signal Description	83
2.3	Memory Map and Register Definition	83
2.3.1	Module Memory Map	84
2.3.2	Register Descriptions	88
2.4	Functional Description	101
2.4.1	Flash Command Operations	101
2.5	Operating Modes	116
2.5.1	Wait Mode	116
2.5.2	Stop Mode	116
2.5.3	Background Debug Mode	116
2.6	Flash Module Security	116
2.6.1	Unsecuring the MCU using Backdoor Key Access	117
2.6.2	Unsecuring the Flash Module in Special Single-Chip Mode using BDM	118
2.7	Resets	118
2.7.1	Flash Reset Sequence	118
2.7.2	Reset While Flash Command Active	118
2.8	Interrupts	118
2.8.1	Description of Flash Interrupt Operation	119

Chapter 3

Port Integration Module (PIM9E256V1) Block Description

3.1	Introduction	121
3.1.1	Features	121
3.1.2	Block Diagram	122
3.2	External Signal Description	123
3.3	Memory Map and Register Definition	129
3.3.1	Port AD	130
3.3.2	Port M	139
3.3.3	Port P	144
3.3.4	Port Q	147
3.3.5	Port S	150
3.3.6	Port T	154
3.3.7	Port U	157
3.4	Functional Description	161
3.4.1	I/O Register	161
3.4.2	Input Register	161
3.4.3	Data Direction Register	161
3.4.4	Reduced Drive Register	162
3.4.5	Pull Device Enable Register	162
3.4.6	Polarity Select Register	163

Section Number	Title	Page
3.4.7	Pin Configuration Summary	163
3.5	Resets	164
3.5.1	Reset Initialization	164
3.6	Interrupts	165
3.6.1	General	165
3.6.2	Interrupt Sources	166
3.6.3	Operation in Stop Mode	166

Chapter 4

Clocks and Reset Generator (CRGV4) Block Description

4.1	Introduction	167
4.1.1	Features	167
4.1.2	Modes of Operation	168
4.1.3	Block Diagram	168
4.2	External Signal Description	169
4.2.1	V_{DDPLL} , V_{SSPLL} — PLL Operating Voltage, PLL Ground	169
4.2.2	XFC — PLL Loop Filter Pin	169
4.2.3	\overline{RESET} — Reset Pin	170
4.3	Memory Map and Register Definition	170
4.3.1	Module Memory Map	170
4.3.2	Register Descriptions	171
4.4	Functional Description	182
4.4.1	Phase Locked Loop (PLL)	182
4.4.2	System Clocks Generator	185
4.4.3	Clock Monitor (CM)	186
4.4.4	Clock Quality Checker	186
4.4.5	Computer Operating Properly Watchdog (COP)	188
4.4.6	Real-Time Interrupt (RTI)	189
4.4.7	Modes of Operation	189
4.4.8	Low-Power Operation in Run Mode	190
4.4.9	Low-Power Operation in Wait Mode	190
4.4.10	Low-Power Operation in Stop Mode	194
4.5	Resets	198
4.5.1	Clock Monitor Reset	200
4.5.2	Computer Operating Properly Watchdog (COP) Reset	200
4.5.3	Power-On Reset, Low Voltage Reset	201
4.6	Interrupts	202
4.6.1	Real-Time Interrupt	202
4.6.2	PLL Lock Interrupt	202
4.6.3	Self-Clock Mode Interrupt	202

Chapter 5
Oscillator (OSCV2) Block Description

5.1	Introduction	203
5.1.1	Features	203
5.1.2	Modes of Operation	203
5.2	External Signal Description	204
5.2.1	V_{DDPLL} and V_{SSPLL} — PLL Operating Voltage, PLL Ground	204
5.2.2	EXTAL and XTAL — Clock/Crystal Source Pins	204
5.2.3	XCLKS — Colpitts/Pierce Oscillator Selection Signal	205
5.3	Memory Map and Register Definition	206
5.4	Functional Description	206
5.4.1	Amplitude Limitation Control (ALC)	206
5.4.2	Clock Monitor (CM)	206
5.5	Interrupts	206

Chapter 6
Analog-to-Digital Converter (ATD10B16CV4)
Block Description

6.1	Introduction	207
6.1.1	Features	207
6.1.2	Modes of Operation	207
6.1.3	Block Diagram	207
6.2	External Signal Description	209
6.2.1	AN _x (x = 15, 14, 13, 12, 11, 10, 9, 8, 7, 6, 5, 4, 3, 2, 1, 0) — Analog Input Channel x Pins 209	209
6.2.2	ETRIG3, ETRIG2, ETRIG1, ETRIG0 — External Trigger Pins	209
6.2.3	V_{RH} , V_{RL} — High Reference Voltage Pin, Low Reference Voltage Pin	209
6.2.4	V_{DDA} , V_{SSA} — Analog Circuitry Power Supply Pins	209
6.3	Memory Map and Register Definition	209
6.3.1	Module Memory Map	209
6.3.2	Register Descriptions	211
6.4	Functional Description	234
6.4.1	Analog Sub-block	234
6.4.2	Digital Sub-Block	235
6.4.3	Operation in Low Power Modes	236
6.5	Initialization/Application Information	237
6.5.1	Setting up and starting an A/D conversion	237
6.5.2	Aborting an A/D conversion	238
6.6	Resets	238
6.7	Interrupts	239

Section Number	Title	Page
Chapter 7		
Digital-to-Analog Converter (DAC8B1CV1) Block Description		
7.1	Introduction	241
7.1.1	Features	241
7.1.2	Modes of Operation	241
7.1.3	Block Diagram	241
7.2	Signal Description	242
7.2.1	DAO — DAC Channel Output	243
7.2.2	V _{DDA} — DAC Power Supply	243
7.2.3	V _{SSA} — DAC Ground Supply	243
7.2.4	V _{REF} — DAC Reference Supply	243
7.2.5	V _{RL} — DAC Reference Ground Supply	243
7.3	Memory Map and Registers	243
7.3.1	Module Memory Map	243
7.3.2	Register Descriptions	244
7.4	Functional Description	247
7.4.1	Functional Description	247
7.5	Resets	248
7.5.1	General	248

Chapter 8
Serial Communication Interface (SCIV4)
Block Description

8.1	Revision History	249
8.2	Introduction	249
8.2.1	Glossary	249
8.2.2	Features	250
8.2.3	Modes of Operation	250
8.2.4	Block Diagram	251
8.3	External Signal Descriptions	253
8.3.1	TXD — SCI Transmit Pin	253
8.3.2	RXD — SCI Receive Pin	253
8.4	Memory Map and Register Definition	253
8.4.1	Module Memory Map	253
8.4.2	Register Descriptions	253
8.5	Functional Description	263
8.5.1	Infrared Interface Submodule	264
8.5.2	Data Format	264
8.5.3	Baud Rate Generation	266
8.5.4	Transmitter	267
8.5.5	Receiver	270

Section Number	Title	Page
8.5.6	Single-Wire Operation	278
8.5.7	Loop Operation	279
8.6	Interrupts	279
8.6.1	Description of Interrupt Operation	280
8.6.2	Recovery from Wait Mode	281

Chapter 9

Serial Peripheral Interface (SPIV3) Block Description

9.1	Introduction	283
9.1.1	Features	283
9.1.2	Modes of Operation	283
9.1.3	Block Diagram	284
9.2	External Signal Description	284
9.2.1	MOSI — Master Out/Slave In Pin	284
9.2.2	MISO — Master In/Slave Out Pin	285
9.2.3	\overline{SS} — Slave Select Pin	285
9.2.4	SCK — Serial Clock Pin	285
9.3	Memory Map and Register Definition	285
9.3.1	Module Memory Map	285
9.3.2	Register Descriptions	286
9.4	Functional Description	293
9.4.1	Master Mode	294
9.4.2	Slave Mode	295
9.4.3	Transmission Formats	296
9.4.4	SPI Baud Rate Generation	299
9.4.5	Special Features	300
9.4.6	Error Conditions	301
9.4.7	Operation in Run Mode	302
9.4.8	Operation in Wait Mode	302
9.4.9	Operation in Stop Mode	302
9.5	Reset	303
9.6	Interrupts	303
9.6.1	MODF	303
9.6.2	SPIF	303
9.6.3	SPTEF	303

Chapter 10

Inter-Integrated Circuit (IICV2) Block Description

10.1	Introduction	305
10.1.1	Features	305
10.1.2	Modes of Operation	306
10.1.3	Block Diagram	306

Section Number	Title	Page
10.2	External Signal Description	307
10.2.1	IIC_SCL — Serial Clock Line Pin	307
10.2.2	IIC_SDA — Serial Data Line Pin	307
10.3	Memory Map and Register Definition	307
10.3.1	Module Memory Map	307
10.3.2	Register Descriptions	308
10.4	Functional Description	319
10.4.1	I-Bus Protocol	319
10.4.2	Operation in Run Mode	323
10.4.3	Operation in Wait Mode	323
10.4.4	Operation in Stop Mode	323
10.5	Resets	323
10.6	Interrupts	323
10.7	Initialization/Application Information	324
10.7.1	IIC Programming Examples	324

Chapter 11

Pulse Width Modulator with Fault Protection (PMF15B6C) Module

11.1	Introduction	329
11.1.1	Features	329
11.1.2	Modes of Operation	330
11.1.3	Block Diagrams	330
11.2	Signal Descriptions	332
11.2.1	PWM0–PWM5 Pins	332
11.2.2	FAULT0–FAULT3 Pins	332
11.2.3	IS0–IS2 Pins	332
11.3	Memory Map and Registers	333
11.3.1	Module Memory Map	333
11.3.2	Register Descriptions	336
11.4	Functional Description	359
11.4.1	Block Diagram	359
11.4.2	Prescaler	359
11.4.3	PWM Generator	359
11.4.4	Independent or Complementary Channel Operation	362
11.4.5	Deadtime Generators	364
11.4.6	Software Output Control	372
11.4.7	PWM Generator Loading	375
11.4.8	Fault Protection	379
11.5	Resets	382
11.6	Clocks	382
11.7	Interrupts	382
11.8	Electrical Specifications	382

Section Number	Title	Page
Chapter 12		
Pulse-Width Modulator (PWM8B6CV1) Block Description		
12.1	Introduction	385
12.1.1	Features	385
12.1.2	Modes of Operation	385
12.1.3	Block Diagram	386
12.2	External Signal Description	386
12.2.1	PWM5 — Pulse Width Modulator Channel 5 Pin	386
12.2.2	PWM4 — Pulse Width Modulator Channel 4 Pin	386
12.2.3	PWM3 — Pulse Width Modulator Channel 3 Pin	386
12.2.4	PWM2 — Pulse Width Modulator Channel 2 Pin	387
12.2.5	PWM1 — Pulse Width Modulator Channel 1 Pin	387
12.2.6	PWM0 — Pulse Width Modulator Channel 0 Pin	387
12.3	Memory Map and Register Definition	387
12.3.1	Module Memory Map	387
12.3.2	Register Descriptions	389
12.4	Functional Description	409
12.4.1	PWM Clock Select	409
12.4.2	PWM Channel Timers	412
12.5	Resets	419
12.6	Interrupts	419

Chapter 13
Timer (S12TIM16B4CV1) Block Description

13.1	Introduction	421
13.1.1	Features	421
13.1.2	Modes of Operation	421
13.1.3	Block Diagram	422
13.2	Signal Description	423
13.2.1	Detailed Signal Descriptions	423
13.3	Memory Map and Registers	423
13.3.1	Overview	423
13.3.2	Module Memory Map	423
13.3.3	Register Descriptions	425
13.4	Functional Description	438
13.4.1	General	438
13.4.2	Prescaler	439
13.4.3	Input Capture	440
13.4.4	Output Compare	440
13.4.5	Pulse Accumulator	441
13.5	Resets	442
13.5.1	General	442

Section Number	Title	Page
13.6	Interrupts	442
13.6.1	General	442
13.6.2	Description of Interrupt Operation	444

Chapter 14

Dual Output Voltage Regulator (VREG3V3V2)

Block Description

14.1	Introduction	445
14.1.1	Features	445
14.1.2	Modes of Operation	445
14.1.3	Block Diagram	446
14.2	External Signal Description	447
14.2.1	V_{DDR} — Regulator Power Input	447
14.2.2	V_{DDA} , V_{SSA} — Regulator Reference Supply	447
14.2.3	V_{DD} , V_{SS} — Regulator Output1 (Core Logic)	448
14.2.4	V_{DDPLL} , V_{SSPLL} — Regulator Output2 (PLL)	448
14.2.5	V_{REGEN} — Optional Regulator Enable	448
14.3	Memory Map and Register Definition	448
14.3.1	Module Memory Map	448
14.3.2	Register Descriptions	449
14.4	Functional Description	449
14.4.1	REG — Regulator Core	450
14.4.2	Full-Performance Mode	450
14.4.3	Reduced-Power Mode	450
14.4.4	LVD — Low-Voltage Detect	450
14.4.5	POR — Power-On Reset	450
14.4.6	LVR — Low-Voltage Reset	450
14.4.7	CTRL — Regulator Control	450
14.5	Resets	451
14.5.1	Power-On Reset	451
14.5.2	Low-Voltage Reset	451
14.6	Interrupts	451
14.6.1	LVI — Low-Voltage Interrupt	451

Chapter 15

Background Debug Module (BDMV4) Block Description

15.1	Introduction	453
15.1.1	Features	453
15.1.2	Modes of Operation	454
15.2	External Signal Description	454
15.2.1	BKGD — Background Interface Pin	455

Section Number	Title	Page
15.2.2	$\overline{\text{TAGHI}}$ — High Byte Instruction Tagging Pin	455
15.2.3	$\overline{\text{TAGLO}}$ — Low Byte Instruction Tagging Pin	455
15.3	Memory Map and Register Definition	456
15.3.1	Module Memory Map	456
15.3.2	Register Descriptions	457
15.4	Functional Description	462
15.4.1	Security	462
15.4.2	Enabling and Activating BDM	462
15.4.3	BDM Hardware Commands	463
15.4.4	Standard BDM Firmware Commands	464
15.4.5	BDM Command Structure	465
15.4.6	BDM Serial Interface	467
15.4.7	Serial Interface Hardware Handshake Protocol	470
15.4.8	Hardware Handshake Abort Procedure	472
15.4.9	SYNC — Request Timed Reference Pulse	475
15.4.10	Instruction Tracing	475
15.4.11	Instruction Tagging	476
15.4.12	Serial Communication Time-Out	476
15.4.13	Operation in Wait Mode	477
15.4.14	Operation in Stop Mode	477

Chapter 16

Debug Module (DBGV1) Block Description

16.1	Introduction	479
16.1.1	Features	479
16.1.2	Modes of Operation	481
16.1.3	Block Diagram	481
16.2	External Signal Description	483
16.3	Memory Map and Register Definition	484
16.3.1	Module Memory Map	484
16.3.2	Register Descriptions	484
16.4	Functional Description	500
16.4.1	DBG Operating in BKP Mode	500
16.4.2	DBG Operating in DBG Mode	502
16.4.3	Breakpoints	509
16.5	Resets	510
16.6	Interrupts	510

Chapter 17

Interrupt (INTV1) Block Description

17.1	Introduction	513
17.1.1	Features	514

Section Number	Title	Page
17.1.2	Modes of Operation	514
17.2	External Signal Description	515
17.3	Memory Map and Register Definition	515
17.3.1	Module Memory Map	515
17.3.2	Register Descriptions	515
17.4	Functional Description	517
17.4.1	Low-Power Modes	518
17.5	Resets	518
17.6	Interrupts	518
17.6.1	Interrupt Registers	518
17.6.2	Highest Priority I-Bit Maskable Interrupt	518
17.6.3	Interrupt Priority Decoder	519
17.7	Exception Priority	519

Chapter 18

Multiplexed External Bus Interface (MEBIV3)

18.1	Introduction	521
18.1.1	Features	521
18.1.2	Modes of Operation	523
18.2	External Signal Description	523
18.3	Memory Map and Register Definition	525
18.3.1	Module Memory Map	526
18.3.2	Register Descriptions	526
18.4	Functional Description	543
18.4.1	Detecting Access Type from External Signals	543
18.4.2	Stretched Bus Cycles	544
18.4.3	Modes of Operation	544
18.4.4	Internal Visibility	549
18.4.5	Low-Power Options	549

Chapter 19

Module Mapping Control (MMCV4) Block Description

19.1	Introduction	551
19.1.1	Features	552
19.1.2	Modes of Operation	552
19.2	External Signal Description	552
19.3	Memory Map and Register Definition	552
19.3.1	Module Memory Map	552
19.3.2	Register Descriptions	554
19.4	Functional Description	564
19.4.1	Bus Control	564
19.4.2	Address Decoding	564

Section Number	Title	Page
19.4.3	Memory Expansion	566

Appendix A Electrical Characteristics

A.1	General	571
A.1.1	Parameter Classification	571
A.1.2	Power Supply	572
A.1.3	Pins	573
A.1.4	Current Injection	573
A.1.5	Absolute Maximum Ratings	574
A.1.6	ESD Protection and Latch-up Immunity	575
A.1.7	Operating Conditions	576
A.1.8	Power Dissipation and Thermal Characteristics	576
A.1.9	I/O Characteristics	578
A.1.10	Supply Currents	579
A.2	Voltage Regulator	581
A.2.1	Chip Power-up and LVI/LVR Graphical Explanation	582
A.2.2	Output Loads	583
A.3	Startup, Oscillator, and PLL	583
A.3.1	Startup	583
A.3.2	Oscillator	585
A.3.3	Phase Locked Loop	586
A.4	Flash NVM	590
A.4.1	NVM Timing	590
A.4.2	NVM Reliability	592
A.5	SPI Characteristics	593
A.5.1	Master Mode	593
A.5.2	Slave Mode	595
A.6	ATD Characteristics	597
A.6.1	ATD Operating Characteristics — 5V Range	597
A.6.2	ATD Operating Characteristics — 3.3V Range	597
A.6.3	Factors Influencing Accuracy	598
A.6.4	ATD Accuracy — 5V Range	599
A.6.5	ATD Accuracy — 3.3V Range	600
A.7	DAC Characteristics	602
A.7.1	DAC Operating Characteristics	602
A.8	External Bus Timing	602

Appendix B Ordering Information and Mechanical Drawings

Section Number

Title

Page

Chapter 1

MC9S12E256 Device Overview (MC9S12E256DGV1)

1.1 Introduction

The MC9S12E256 is a 112/80 pin low cost general purpose MCU comprised of standard on-chip peripherals including a 16-bit central processing unit (HCS12 CPU), 256K bytes of Flash EEPROM, 16K bytes of RAM, three asynchronous serial communications interface modules (SCI), a serial peripheral interface (SPI), an Inter-IC Bus (IIC), three 4-channel 16-bit timer modules (TIM), a 6-channel 15-bit Pulse Modulator with Fault protection module (PMF), a 6-channel 8-bit Pulse Width Modulator (PWM), a 16-channel 10-bit analog-to-digital converter (ADC), and two 1-channel 8-bit digital-to-analog converters (DAC). The MC9S12E256 has full 16-bit data paths throughout. The inclusion of a PLL circuit allows power consumption and performance to be adjusted to suit operational requirements. In addition to the I/O ports available on each module, 16 dedicated I/O port bits are available with Wake-Up capability from STOP or WAIT mode. Furthermore, an on chip bandgap based voltage regulator (VREG) generates the internal digital supply voltage of 2.5V (VDD) from a 2.97V to 5.5V external supply range.

1.1.1 Features

- 16-bit HCS12 CORE
 - HCS12 CPU
 - Upward compatible with M68HC11 instruction set
 - Interrupt stacking and programmer’s model identical to M68HC11
 - Instruction queue
 - Enhanced indexed addressing
 - Module Mapping Control (MMC)
 - Interrupt control (INT)
 - Background Debug Module (BDM)
 - Debugger (DBG12) including breakpoints and change-of-flow trace buffer
 - Multiplexed External Bus Interface (MEBI)
- Wake-Up interrupt inputs
 - Up to 16 port bits available for wake up interrupt function with digital filtering
- Memory
 - 256K Byte Flash EEPROM
 - 16K Byte RAM

- Two 1-channel Digital-to-Analog Converters (DAC)
 - 8-bit resolution
- Analog-to-Digital Converter (ADC)
 - 16-channel module with 10-bit resolution
 - External conversion trigger capability
- Three 4-channel Timers (TIM)
 - Programmable input capture or output compare channels
 - Simple PWM mode
 - Counter modulo reset
 - External event counting
 - Gated time accumulation
- 6 PWM channels (PWM)
 - Programmable period and duty cycle
 - 8-bit 6-channel or 16-bit 3-channel
 - Separate control for each pulse width and duty cycle
 - Center-aligned or left-aligned outputs
 - Programmable clock select logic with a wide range of frequencies
 - Fast emergency shutdown input
- 6-channel Pulse width Modulator with Fault protection (PMF)
 - Three independent 15-bit counters with synchronous mode
 - Complementary channel operation
 - Edge and center aligned PWM signals
 - Programmable dead time insertion
 - Integral reload rates from 1 to 16
 - Four fault protection shut down input pins
 - Three current sense input pins
- Serial interfaces
 - Three asynchronous serial communication interfaces (SCI)
 - Synchronous serial peripheral interface (SPI)
 - Inter-IC Bus (IIC)
- Clock and Reset Generator (CRG)
 - Windowed COP watchdog
 - Real Time interrupt
 - Clock Monitor
 - Pierce or low current Colpitts oscillator
 - Phase-locked loop clock frequency multiplier
 - Self Clock mode in absence of external clock
 - Low power 0.5 to 16Mhz crystal oscillator reference clock

- Operating frequency
 - 50MHz equivalent to 25MHz Bus Speed
- Internal 2.5V Regulator
 - Input voltage range from 2.97V to 5.5V
 - Low power mode capability
 - Includes low voltage reset (LVR) circuitry
 - Includes low voltage interrupt (LVI) circuitry
- 112-Pin LQFP or 80-Pin QFP package
 - Up to 90 I/O lines with 5V input and drive capability (112 pin package)
 - Up to two dedicated 5V input only lines (IRQ and XIRQ)
 - Sixteen 3.3V/5V A/D converter inputs
- Development Support.
 - Single-wire background debug™ mode
 - On-chip hardware breakpoints
 - Enhanced debug features

1.1.2 Modes of Operation

User modes (**Expanded modes are only available in the 112-pin package version**)

- Normal modes
 - Normal Single-Chip Mode
 - Normal Expanded Wide Mode
 - Normal Expanded Narrow Mode
 - Emulation Expanded Wide Mode
 - Emulation Expanded Narrow Mode
- Special Operating Modes
 - Special Single-Chip Mode with active Background Debug Mode
 - Special Test Mode (**Freescale use only**)
 - Special Peripheral Mode (**Freescale use only**)
- Low power modes
 - Stop Mode
 - Pseudo Stop Mode
 - Wait Mode

1.1.3 Block Diagram

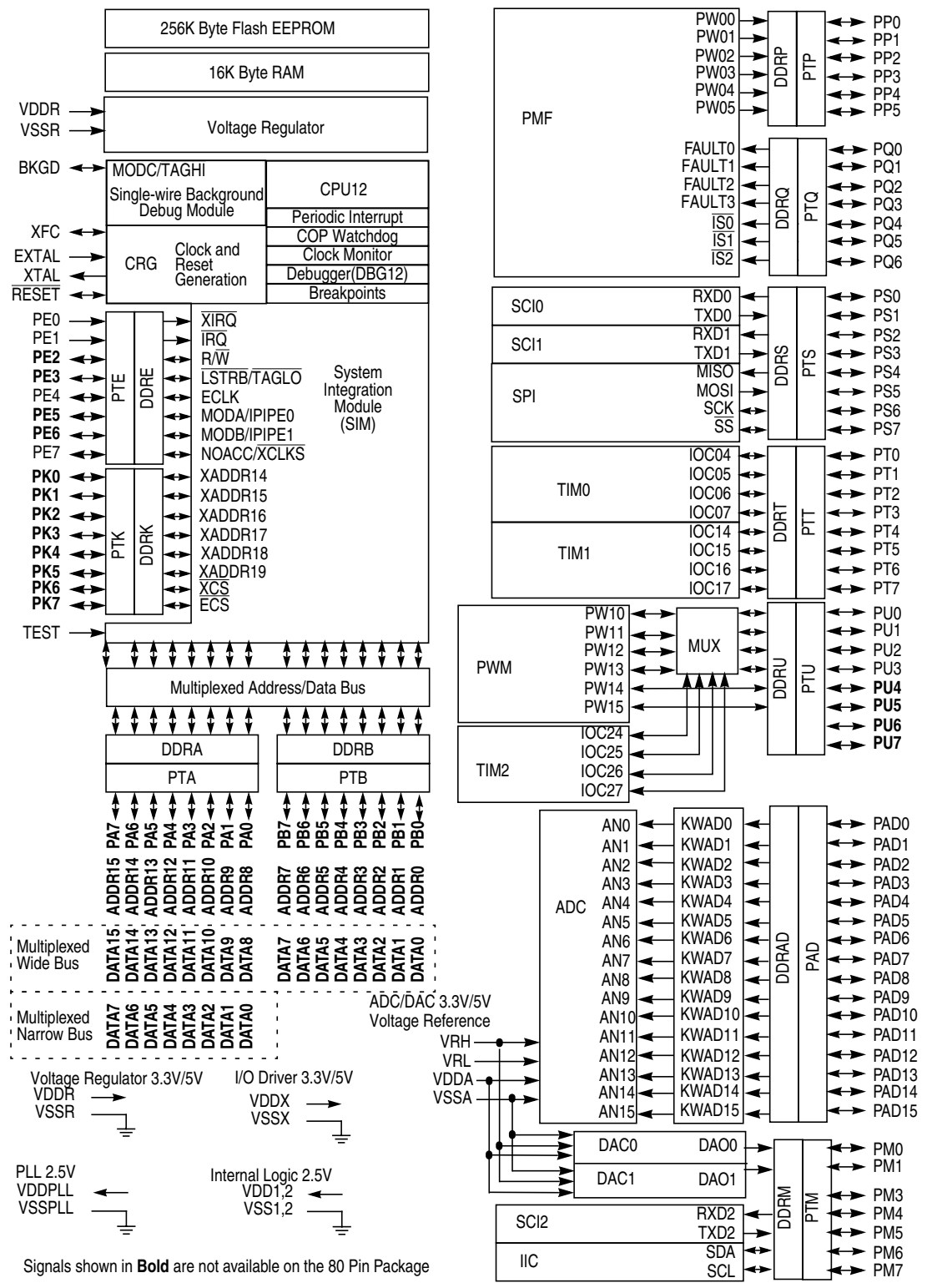

Figure 1-1. MC9S12E256 Block Diagram

1.2 Device Memory Map

Table 1-1 shows the device register map of the MC9S12E256 after reset. Figure 1-2 illustrates the device memory map with Flash and RAM.

Table 1-1. Device Register Map Overview

Address	Module	Size
0x0000–0x0017	CORE (Ports A, B, E, Modes, Inits, Test)	24
0x0018	Reserved	1
0x0019	Voltage Regulator (VREG)	1
0x001A–0x001B	Device ID register (PARTID)	2
0x001C–0x001F	CORE (MEMSIZ, IRQ, HPRIO)	4
0x0020–0x002F	CORE (DBG)	16
0x0030–0x0033	CORE (PPAGE, Port K)	4
0x0034–0x003F	Clock and Reset Generator (PLL, RTI, COP)	12
0x0040–0x006F	Standard Timer 16-bit 4 channels (TIM0)	48
0x0070–0x007F	Reserved	16
0x0080–0x00AF	Analog to Digital Converter 10-bit 16 channels (ATD)	48
0x00B0–0x00C7	Reserved	24
0x00C8–0x00CF	Serial Communications Interface 0 (SCI0)	8
0x00D0–0x00D7	Serial Communications Interface 1 (SCI1)	8
0x00D8–0x00DF	Serial Peripheral Interface (SPI)	8
0x00E0–0x00E7	Inter IC Bus	8
0x00E8–0x00EF	Serial Communications Interface 2 (SCI2)	8
0x00F0–0x00F3	Digital to Analog Converter 8-bit 1-channel (DAC0)	4
0x00F4–0x00F7	Digital to Analog Converter 8-bit 1-channel (DAC1)	4
0x00F8–0x00FF	Reserved	8
0x0100–0x010F	Flash Control Register	16
0x0110–0x013F	Reserved	48
0x0140–0x016F	Standard Timer 16-bit 4 channels (TIM1)	48
0x0170–0x017F	Reserved	16
0x0180–0x01AF	Standard Timer 16-bit 4 channels (TIM2)	48
0x01B0–0x01DF	Reserved	48
0x01E0–0x01FF	Pulse Width Modulator 8-bit 6 channels (PWM)	32
0x0200–0x023F	Pulse Width Modulator with Fault 15-bit 6 channels (PMF)	64
0x0240–0x027F	Port Integration Module (PIM)	64
0x0280–0x03FF	Reserved	384

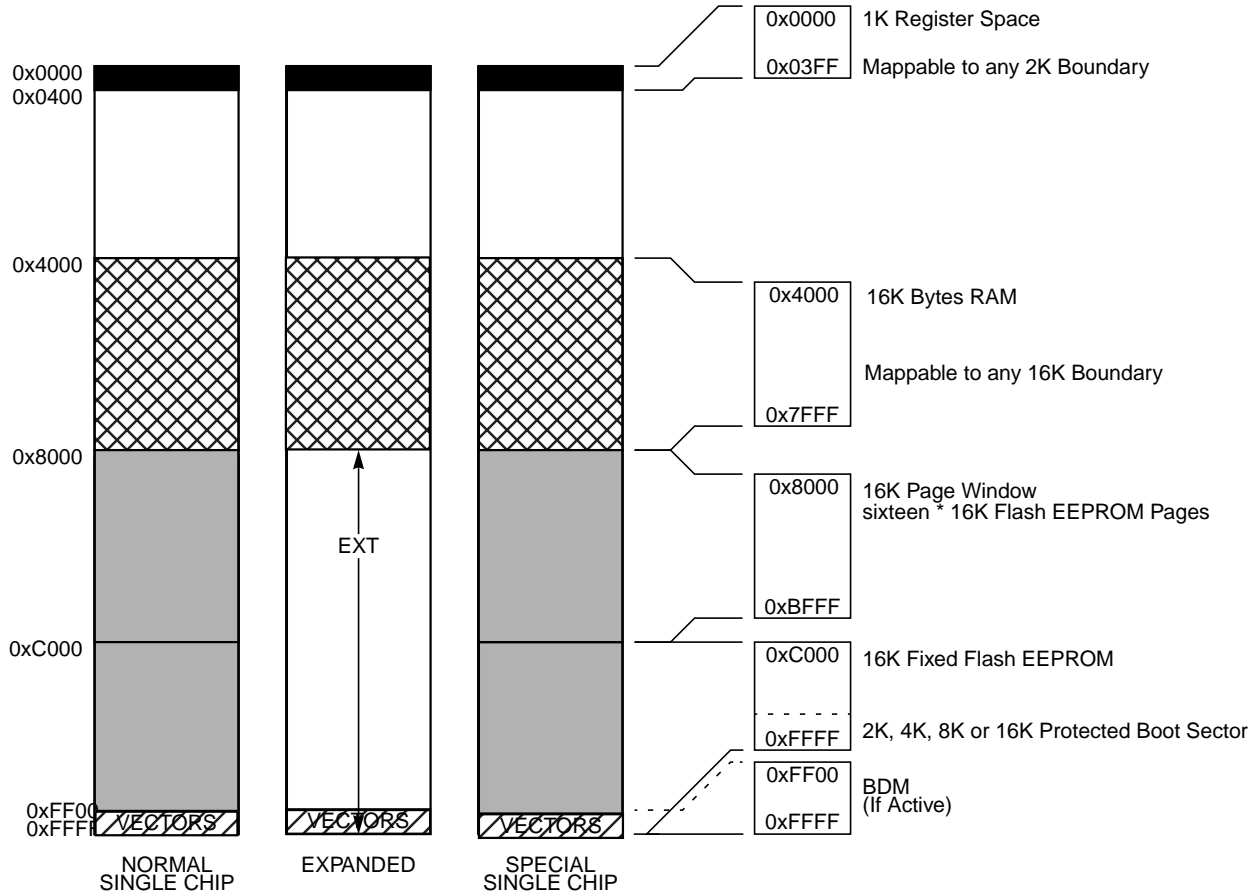

The figure shows a useful map, which is not the map out of reset. After reset the map is:

- 0x0000–0x03FF: Register Space
- 0x0000–0x3FFF: 16K RAM (only 15K RAM visible 0x0400–0x3FFF)

Figure 1-2. MC9S12E256 User Configurable Memory Map

1.2.1 Detailed Register Map

0x0000 – 0x000F MEBI Map 1 of 3 (HCS12 Multiplexed External Bus Interface)

Address	Name		Bit 7	Bit 6	Bit 5	Bit 4	Bit 3	Bit 2	Bit 1	Bit 0
0x0000	PORTA	R W	Bit 7	6	5	4	3	2	1	Bit 0
0x0001	PORTB	R W	Bit 7	6	5	4	3	2	1	Bit 0
0x0002	DDRA	R W	Bit 7	6	5	4	3	2	1	Bit 0
0x0003	DDRB	R W	Bit 7	6	5	4	3	2	1	Bit 0
0x0004	Reserved	R W	0	0	0	0	0	0	0	0
0x0005	Reserved	R W	0	0	0	0	0	0	0	0
0x0006	Reserved	R W	0	0	0	0	0	0	0	0
0x0007	Reserved	R W	0	0	0	0	0	0	0	0
0x0008	PORTE	R W	Bit 7	6	5	4	3	2	Bit 1	Bit 0
0x0009	DDRE	R W	Bit 7	6	5	4	3	Bit 2	0	0
0x000A	PEAR	R W	NOACCE	0	PIPOE	NECLK	LSTRE	RDWE	0	0
0x000B	MODE	R W	MODC	MODB	MODA	0	IVIS	0	EMK	EME
0x000C	PUCR	R W	PUPKE	0	0	PUPEE	0	0	PUPBE	PUPAE
0x000D	RDRIV	R W	RDPK	0	0	RDPE	0	0	RDPB	RDPA
0x000E	EBICTL	R W	0	0	0	0	0	0	0	ESTR
0x000F	Reserved	R W	0	0	0	0	0	0	0	0

0x0010 – 0x0014 MMC Map 1 of 4 (HCS12 Module Mapping Control)

Address	Name		Bit 7	Bit 6	Bit 5	Bit 4	Bit 3	Bit 2	Bit 1	Bit 0
0x0010	INITRM	R	RAM15	RAM14	RAM13	RAM12	RAM11	0	0	RAMHAL
		W								
0x0011	INITRG	R	0	REG14	REG13	REG12	REG11	0	0	0
		W								
0x0012	INITEE	R	EE15	EE14	EE13	EE12	EE11	0	0	EEON
		W								
0x0013	MISC	R	0	0	0	0	EXSTR1	EXSTR0	ROMHM	ROMON
		W								
0x0014	MTST0	R	Bit 7	6	5	4	3	2	1	Bit 0
		W								

0x0015 – 0x0016 INT Map 1 of 2 (HCS12 Interrupt)

Address	Name		Bit 7	Bit 6	Bit 5	Bit 4	Bit 3	Bit 2	Bit 1	Bit 0
0x0015	ITCR	R	0	0	0	WRINT	ADR3	ADR2	ADR1	ADR0
		W								
0x0016	ITEST	R	INTE	INTC	INTA	INT8	INT6	INT4	INT2	INT0
		W								

0x0017 – 0x0017 MMC Map 2 of 4 (HCS12 Module Mapping Control)

Address	Name		Bit 7	Bit 6	Bit 5	Bit 4	Bit 3	Bit 2	Bit 1	Bit 0
0x0017	MTST1	R	Bit 7	6	5	4	3	2	1	Bit 0
		W								

0x0018 – 0x0018 Miscellaneous Peripherals (Device User Guide)

Address	Name		Bit 7	Bit 6	Bit 5	Bit 4	Bit 3	Bit 2	Bit 1	Bit 0
0x0018	Reserved	R	0	0	0	0	0	0	0	0
		W								

0x0019 – 0x0019 VREG3V3 (Voltage Regulator)

Address	Name		Bit 7	Bit 6	Bit 5	Bit 4	Bit 3	Bit 2	Bit 1	Bit 0
0x0019	VREGCTRL	R	0	0	0	0	0	LVDS	LVIE	LVIF
		W								

0x001A – 0x001B Miscellaneous Peripherals (Device User Guide)

Address	Name		Bit 7	Bit 6	Bit 5	Bit 4	Bit 3	Bit 2	Bit 1	Bit 0
0x001A	PARTIDH	R	ID15	ID14	ID13	ID12	ID11	ID10	ID9	ID8
		W								
0x001B	PARTIDL	R	ID7	ID6	ID5	ID4	ID3	ID2	ID1	ID0
		W								

0x001C – 0x001D MMC Map 3 of 4 (HCS12 Module Mapping Control, Device User Guide)

Address	Name		Bit 7	Bit 6	Bit 5	Bit 4	Bit 3	Bit 2	Bit 1	Bit 0
0x001C	MEMSIZE0	R	reg_sw0	0	eep_sw1	eep_sw0	0	ram_sw2	ram_sw1	ram_sw0
		W								
0x001D	MEMSIZE1	R	rom_sw1	rom_sw0	0	0	0	0	pag_sw1	pag_sw0
		W								

0x001E – 0x001E MEBI Map 2 of 3 (HCS12 Multiplexed External Bus Interface)

Address	Name		Bit 7	Bit 6	Bit 5	Bit 4	Bit 3	Bit 2	Bit 1	Bit 0
0x001E	INTCR	R	IRQE	IRQEN	0	0	0	0	0	0
		W								

0x001F – 0x001F INT Map 2 of 2 (HCS12 Interrupt)

Address	Name		Bit 7	Bit 6	Bit 5	Bit 4	Bit 3	Bit 2	Bit 1	Bit 0
0x001F	HPRIO	R	PSEL7	PSEL6	PSEL5	PSEL4	PSEL3	PSEL2	PSEL1	0
		W								

0x0020 – 0x002F DBG (Including BKP) Map 1 of 1 (HCS12 Debug)

Address	Name		Bit 7	Bit 6	Bit 5	Bit 4	Bit 3	Bit 2	Bit 1	Bit 0
0x0020	DBGC1 —	R	DBGEN	ARM	TRGSEL	BEGIN	DBGBRK	0	CAPMOD	
		W								
0x0021	DBGSC —	R	AF	BF	CF	0	TRG			
		W								
0x0022	DBGTBH —	R	Bit 15	Bit 14	Bit 13	Bit 12	Bit 11	Bit 10	Bit 9	Bit 8
		W								
0x0023	DBGTBL —	R	Bit 7	Bit 6	Bit 5	Bit 4	Bit 3	Bit 2	Bit 1	Bit 0
		W								
0x0024	DBGCNT —	R	TBF	0	CNT					
		W								
0x0025	DBGCCX —	R	PAGSEL		EXTCMP					
		W								

0x0020 – 0x002F DBG (Including BKP) Map 1 of 1 (HCS12 Debug) (continued)

Address	Name		Bit 7	Bit 6	Bit 5	Bit 4	Bit 3	Bit 2	Bit 1	Bit 0
0x0026	DBGCCCH	R	Bit 15	14	13	12	11	10	9	Bit 8
	—	W								
0x0027	DBGCCCL	R	Bit 7	6	5	4	3	2	1	Bit 0
	—	W								
0x0028	DBGCC2	R	BKABEN	FULL	BDM	TAGAB	BKCEN	TAGC	RWCEN	RWC
	BKPCT0	W								
0x0029	DBGCC3	R	BKAMBH	BKAMBL	BKMBMH	BKMBML	RWAEN	RWA	RWBEN	RWB
	BKPCT1	W								
0x002A	DBGCCAX	R	PAGSEL		EXTCMP					
	BKP0X	W								
0x002B	DBGCCAH	R	Bit 15	14	13	12	11	10	9	Bit 8
	BKP0H	W								
0x002C	DBGCCAL	R	Bit 7	6	5	4	3	2	1	Bit 0
	BKP0L	W								
0x002D	DBGCCBX	R	PAGSEL		EXTCMP					
	BKP1X	W								
0x002E	DBGCCBH	R	Bit 15	14	13	12	11	10	9	Bit 8
	BKP1H	W								
0x002F	DBGCCBL	R	Bit 7	6	5	4	3	2	1	Bit 0
	BKP1L	W								

0x0030 – 0x0031 MMC Map 4 of 4 (HCS12 Module Mapping Control)

Address	Name		Bit 7	Bit 6	Bit 5	Bit 4	Bit 3	Bit 2	Bit 1	Bit 0
0x0030	PPAGE	R	0	0	PIX5	PIX4	PIX3	PIX2	PIX1	PIX0
		W								
0x0031	Reserved	R	0	0	0	0	0	0	0	0
		W								

0x0032 – 0x0033 MEBI Map 3 of 3 (HCS12 Multiplexed External Bus Interface)

Address	Name		Bit 7	Bit 6	Bit 5	Bit 4	Bit 3	Bit 2	Bit 1	Bit 0
0x0032	PORTK	R	ECS	XCS	XAB19	XAB18	XAB17	XAB16	XAB15	XAB14
		W								
0x0033	DDRK	R	Bit 7	6	5	4	3	2	1	Bit 0
		W								

0x0034 – 0x003F CRG (Clock and Reset Generator)

Address	Name		Bit 7	Bit 6	Bit 5	Bit 4	Bit 3	Bit 2	Bit 1	Bit 0
0x0034	SYNR	R	0	0	SYN5	SYN4	SYN3	SYN2	SYN1	SYN0
		W								
0x0035	REFDV	R	0	0	0	0	REFDV3	REFDV2	REFDV1	REFDV0
		W								
0x0036	CTFLG TEST ONLY	R	TOUT7	TOUT6	TOUT5	TOUT4	TOUT3	TOUT2	TOUT1	TOUT0
		W								
0x0037	CRGFLG	R	RTIF	PROF	0	LOCKIF	LOCK	TRACK	SCMIF	SCM
		W								
0x0038	CRGINT	R	RTIE	0	0	LOCKIE	0	0	SCMIE	0
		W								
0x0039	CLKSEL	R	PLLSEL	PSTP	SYSWAI	ROAWAI	PLLWAI	CWAI	RTIWAI	COPWAI
		W								
0x003A	PLLCTL	R	CME	PLLON	AUTO	ACQ	0	PRE	PCE	SCME
		W								
0x003B	RTICTL	R	0	RTR6	RTR5	RTR4	RTR3	RTR2	RTR1	RTR0
		W								
0x003C	COPCTL	R	WCOP	RSBCK	0	0	0	CR2	CR1	CR0
		W								
0x003D	FORBYP TEST ONLY	R	RTIBYP	COPBYP	0	PLLBYB	0	0	FCM	0
		W								
0x003E	CTCTL TEST ONLY	R	TCTL7	TCTL6	TCTL5	TCTL4	TCTL3	TCTL2	TCTL1	TCTL0
		W								
0x003F	ARMCOP	R	0	0	0	0	0	0	0	0
		W	Bit 7	6	5	4	3	2	1	Bit 0

0x0040 – 0x006F TIM0 (Timer 16 Bit 4 Channels) (Sheet 1 of 4)

Address	Name		Bit 7	Bit 6	Bit 5	Bit 4	Bit 3	Bit 2	Bit 1	Bit 0
0x0040	TIOS	R	IOS7	IOS6	IOS5	IOS4	0	0	0	0
		W								
0x0041	CFORC	R	0	0	0	0	0	0	0	0
		W	FOC7	FOC6	FOC5	FOC4				
0x0042	OC7M	R	OC7M7	OC7M6	OC7M5	OC7M4	0	0	0	0
		W								
0x0043	OC7D	R	OC7D7	OC7D6	OC7D5	OC7D4	0	0	0	0
		W								
0x0044	TCNT (hi)	R	Bit 15	14	13	12	11	10	9	Bit 8
		W								
0x0045	TCNT (lo)	R	Bit 7	6	5	4	3	2	1	Bit 0
		W								

0x0040 – 0x006F TIM0 (Timer 16 Bit 4 Channels) (Sheet 2 of 4)

Address	Name		Bit 7	Bit 6	Bit 5	Bit 4	Bit 3	Bit 2	Bit 1	Bit 0
0x0046	TSCR1	R	TEN	TSWAI	TSFRZ	TFFCA	0	0	0	0
		W								
0x0047	TTOV	R	TOV7	TOV6	TOV5	TOV4	0	0	0	0
		W								
0x0048	TCTL1	R	OM7	OL7	OM6	OL6	OM5	OL5	OM4	OL4
		W								
0x0049	Reserved	R	0	0	0	0	0	0	0	0
		W								
0x004A	TCTL3	R	EDG7B	EDG7A	EDG6B	EDG6A	EDG5B	EDG5A	EDG4B	EDG4A
		W								
0x004B	Reserved	R	0	0	0	0	0	0	0	0
		W								
0x004C	TIE	R	C7I	C6I	C5I	C4I	0	0	0	0
		W								
0x004D	TSCR2	R	TOI	0	0	0	TCRE	PR2	PR1	PR0
		W								
0x004E	TFLG1	R	C7F	C6F	C5F	C4F	0	0	0	0
		W								
0x004F	TFLG2	R	TOF	0	0	0	0	0	0	0
		W								
0x0050	Reserved	R	0	0	0	0	0	0	0	0
		W								
0x0051	Reserved	R	0	0	0	0	0	0	0	0
		W								
0x0052	Reserved	R	0	0	0	0	0	0	0	0
		W								
0x0053	Reserved	R	0	0	0	0	0	0	0	0
		W								
0x0054	Reserved	R	0	0	0	0	0	0	0	0
		W								
0x0055	Reserved	R	0	0	0	0	0	0	0	0
		W								
0x0056	Reserved	R	0	0	0	0	0	0	0	0
		W								
0x0057	Reserved	R	0	0	0	0	0	0	0	0
		W								
0x0058	TC4 (hi)	R	Bit 15	14	13	12	11	10	9	Bit 8
		W								

0x0040 – 0x006F TIM0 (Timer 16 Bit 4 Channels) (Sheet 3 of 4)

Address	Name		Bit 7	Bit 6	Bit 5	Bit 4	Bit 3	Bit 2	Bit 1	Bit 0
0x0059	TC4 (lo)	R W	Bit 7	6	5	4	3	2	1	Bit 0
0x005A	TC5 (hi)	R W	Bit 15	14	13	12	11	10	9	Bit 8
0x005B	TC5 (lo)	R W	Bit 7	6	5	4	3	2	1	Bit 0
0x005C	TC6 (hi)	R W	Bit 15	14	13	12	11	10	9	Bit 8
0x005D	TC6 (lo)	R W	Bit 7	6	5	4	3	2	1	Bit 0
0x005E	TC7 (hi)	R W	Bit 15	14	13	12	11	10	9	Bit 8
0x005F	TC7 (lo)	R W	Bit 7	6	5	4	3	2	1	Bit 0
0x0060	PACTL	R W	0	PAEN	PAMOD	PEDGE	CLK1	CLK0	PAOVI	PAI
0x0061	PAFLG	R W	0	0	0	0	0	0	PAOVF	PAIF
0x0062	PACNT (hi)	R W	Bit 15	14	13	12	11	10	9	Bit 8
0x0063	PACNT (lo)	R W	Bit 7	6	5	4	3	2	1	Bit 0
0x0064	Reserved	R W	0	0	0	0	0	0	0	0
0x0065	Reserved	R W	0	0	0	0	0	0	0	0
0x0066	Reserved	R W	0	0	0	0	0	0	0	0
0x0067	Reserved	R W	0	0	0	0	0	0	0	0
0x0068	Reserved	R W	0	0	0	0	0	0	0	0
0x0069	Reserved	R W	0	0	0	0	0	0	0	0
0x006A	Reserved	R W	0	0	0	0	0	0	0	0
0x006B	Reserved	R W	0	0	0	0	0	0	0	0

0x0040 – 0x006F TIM0 (Timer 16 Bit 4 Channels) (Sheet 4 of 4)

Address	Name		Bit 7	Bit 6	Bit 5	Bit 4	Bit 3	Bit 2	Bit 1	Bit 0
0x006C	Reserved	R	0	0	0	0	0	0	0	0
		W								
0x006D	Reserved	R	0	0	0	0	0	0	0	0
		W								
0x006E	Reserved	R	0	0	0	0	0	0	0	0
		W								
0x006F	Reserved	R	0	0	0	0	0	0	0	0
		W								

0x0070 – 0x007F Reserved

Address	Name		Bit 7	Bit 6	Bit 5	Bit 4	Bit 3	Bit 2	Bit 1	Bit 0
0x0070– 0x007F	Reserved	R	0	0	0	0	0	0	0	0
		W								

0x0080 – 0x00AF ATD (Analog to Digital Converter 10 Bit 16 Channel) (Sheet 1 of 3)

Address	Name		Bit 7	Bit 6	Bit 5	Bit 4	Bit 3	Bit 2	Bit 1	Bit 0
0x0080	ATDCTL0	R	0	0	0	0	WRAP3 ¹	WRAP2 ¹	WRAP1 ¹	WRAP0 ¹
		W								
0x0081	ATDCTL1	R	ETRIGSEL ²	0	0	0	ETRIGCH3 ²	ETRIGCH2 ²	ETRIGCH1 ²	ETRIGCH0 ²
		W								
0x0082	ATDCTL2	R	ADPU	AFFC	AWAI	ETRIGLE	ETRIGP	ETRIG	ASCIE	ASCIF
		W								
0x0083	ATDCTL3	R	0	S8C	S4C	S2C	S1C	FIFO	FRZ1	FRZ0
		W								
0x0084	ATDCTL4	R	SRES8	SMP1	SMP0	PRS4	PRS3	PRS2	PRS1	PRS0
		W								
0x0085	ATDCTL5	R	DJM	DSGN	SCAN	MULT	0	CC	CB	CA
		W								
0x0086	ATDSTAT0	R	SCF	0	ETORF	FIFOR	0	CC2	CC1	CC0
		W								
0x0087	Reserved	R	0	0	0	0	0	0	0	0
		W								
0x0088	ATDTEST0	R	0	0	0	0	0	0	0	0
		W								
0x0089	ATDTEST1	R	0	0	0	0	0	0	0	SC
		W								
0x008A	ATDSTAT0	R	CCF15	CCF14	CCF13	CCF12	CCF11	CCF10	CCF9	CCF8
		W								

0x0080 – 0x00AF ATD (Analog to Digital Converter 10 Bit 16 Channel) (Sheet 2 of 3)

Address	Name		Bit 7	Bit 6	Bit 5	Bit 4	Bit 3	Bit 2	Bit 1	Bit 0
0x008B	ATDSTAT1	R	CCF7	CCF6	CCF5	CCF4	CCF3	CCF2	CCF1	CCF0
		W								
0x008C	ATDDIEN0	R	IEN15	IEN14	IEN13	IEN12	IEN11	IEN10	IEN9	IEN8
		W								
0x008D	ATDDIEN1	R	IEN7	IEN6	IEN5	IEN4	IEN3	IEN2	IEN1	IEN0
		W								
0x008E	PORTAD0	R	PTAD15	PTAD14	PTAD13	PTAD12	PTAD11	PTAD10	PTAD9	PTAD8
		W								
0x008F	PORTAD1	R	PTAD7	PTAD6	PTAD5	PTAD4	PTAD3	PTAD2	PTAD1	PTAD0
		W								
0x0090	ATDDR0H	R	Bit15	14	13	12	11	10	9	Bit8
		W								
0x0091	ATDDR0L	R	Bit7	Bit6	0	0	0	0	0	0
		W								
0x0092	ATDDR1H	R	Bit15	14	13	12	11	10	9	Bit8
		W								
0x0093	ATDDR1L	R	Bit7	Bit6	0	0	0	0	0	0
		W								
0x0094	ATDDR2H	R	Bit15	14	13	12	11	10	9	Bit8
		W								
0x0095	ATDDR2L	R	Bit7	Bit6	0	0	0	0	0	0
		W								
0x0096	ATDDR3H	R	Bit15	14	13	12	11	10	9	Bit8
		W								
0x0097	ATDDR3L	R	Bit7	Bit6	0	0	0	0	0	0
		W								
0x0098	ATDDR4H	R	Bit15	14	13	12	11	10	9	Bit8
		W								
0x0099	ATDDR4L	R	Bit7	Bit6	0	0	0	0	0	0
		W								
0x009A	ATDDR5H	R	Bit15	14	13	12	11	10	9	Bit8
		W								
0x009B	ATDDR5L	R	Bit7	Bit6	0	0	0	0	0	0
		W								
0x009C	ATDDR6H	R	Bit15	14	13	12	11	10	9	Bit8
		W								
0x009D	ATDDR6L	R	Bit7	Bit6	0	0	0	0	0	0
		W								

0x0080 – 0x00AF ATD (Analog to Digital Converter 10 Bit 16 Channel) (Sheet 3 of 3)

Address	Name		Bit 7	Bit 6	Bit 5	Bit 4	Bit 3	Bit 2	Bit 1	Bit 0
0x009E	ATDDR7H	R	Bit15	14	13	12	11	10	9	Bit8
		W								
0x009F	ATDDR7L	R	Bit7	Bit6	0	0	0	0	0	0
		W								
0x00A0	ATDDR8H	R	Bit15	14	13	12	11	10	9	Bit8
		W								
0x00A1	ATDDR8L	R	Bit7	Bit6	0	0	0	0	0	0
		W								
0x00A2	ATDDR9H	R	Bit15	14	13	12	11	10	9	Bit8
		W								
0x00A3	ATDDR9L	R	Bit7	Bit6	0	0	0	0	0	0
		W								
0x00A4	ATDDR10H	R	Bit15	14	13	12	11	10	9	Bit8
		W								
0x00A5	ATDDR10L	R	Bit7	Bit6	0	0	0	0	0	0
		W								
0x00A6	ATDDR11H	R	Bit15	14	13	12	11	10	9	Bit8
		W								
0x00A7	ATDDR11L	R	Bit7	Bit6	0	0	0	0	0	0
		W								
0x00A8	ATDDR12H	R	Bit15	14	13	12	11	10	9	Bit8
		W								
0x00A9	ATDDR12L	R	Bit7	Bit6	0	0	0	0	0	0
		W								
0x00AA	ATDDR13H	R	Bit15	14	13	12	11	10	9	Bit8
		W								
0x00AB	ATDDR13L	R	Bit7	Bit6	0	0	0	0	0	0
		W								
0x00AC	ATDDR14H	R	Bit15	14	13	12	11	10	9	Bit8
		W								
0x00AD	ATDDR14L	R	Bit7	Bit6	0	0	0	0	0	0
		W								
0x00AE	ATDDR15H	R	Bit15	14	13	12	11	10	9	Bit8
		W								
0x00AF	ATDDR15L	R	Bit7	Bit6	0	0	0	0	0	0
		W								

¹ WRAP0–3 bits are available in version V04 of ATD10B16C

² ETRIGSEL and ETRIGCH0–3 bits are available in version V04 of ATD10B16C

0x00B0 – 0x00C7 Reserved

Address	Name		Bit 7	Bit 6	Bit 5	Bit 4	Bit 3	Bit 2	Bit 1	Bit 0
0x00B0– 0x00C7	Reserved	R	0	0	0	0	0	0	0	0
		W								

0x00C8 – 0x00CF SCI0 (Asynchronous Serial Interface)

Address	Name		Bit 7	Bit 6	Bit 5	Bit 4	Bit 3	Bit 2	Bit 1	Bit 0
0x00C8	SCIBDH	R	IREN	TNP1	TNP0	SBR12	SBR11	SBR10	SBR9	SBR8
		W								
0x00C9	SCIBDL	R	SBR7	SBR6	SBR5	SBR4	SBR3	SBR2	SBR1	SBR0
		W								
0x00CA	SCICR1	R	LOOPS	SCISWAI	RSRC	M	WAKE	ILT	PE	PT
		W								
0x00CB	SCICR2	R	TIE	TCIE	RIE	ILIE	TE	RE	RWU	SBK
		W								
0x00CC	SCISR1	R	TDRE	TC	RDRF	IDLE	OR	NF	FE	PF
		W								
0x00CD	SCISR2	R	0	0	0	TXPOL ¹	RXPOL ¹	BRK13	TXDIR	RAF
		W								
0x00CE	SCIDRH	R	R8	T8	0	0	0	0	0	0
		W								
0x00CF	SCIDRL	R	R7	R6	R5	R4	R3	R2	R1	R0
		W	T7	T6	T5	T4	T3	T2	T1	T0

¹ TXPOL and RXPOL bits are available in version V04 of SCI

0x00D0 – 0x00D7 SCI1 (Asynchronous Serial Interface)

Address	Name		Bit 7	Bit 6	Bit 5	Bit 4	Bit 3	Bit 2	Bit 1	Bit 0
0x00D0	SCIBDH	R	IREN	TNP1	TNP0	SBR12	SBR11	SBR10	SBR9	SBR8
		W								
0x00D1	SCIBDL	R	SBR7	SBR6	SBR5	SBR4	SBR3	SBR2	SBR1	SBR0
		W								
0x00D2	SCICR1	R	LOOPS	SCISWAI	RSRC	M	WAKE	ILT	PE	PT
		W								
0x00D3	SCICR2	R	TIE	TCIE	RIE	ILIE	TE	RE	RWU	SBK
		W								
0x00D4	SCISR1	R	TDRE	TC	RDRF	IDLE	OR	NF	FE	PF
		W								

0x00D0 – 0x00D7 SCI1 (Asynchronous Serial Interface) (continued)

Address	Name		Bit 7	Bit 6	Bit 5	Bit 4	Bit 3	Bit 2	Bit 1	Bit 0
0x00D5	SCISR2	R	0	0	0	TXPOL ¹	RXPOL ¹	BRK13	TXDIR	RAF
		W								
0x00D6	SCIDRH	R	R8	T8	0	0	0	0	0	0
		W								
0x00D7	SCIDRL	R	R7	R6	R5	R4	R3	R2	R1	R0
		W	T7	T6	T5	T4	T3	T2	T1	T0

¹ TXPOL and RXPOL are available in version V04 of SCI

0x00D8 – 0x00DF SPI (Serial Peripheral Interface)

Address	Name		Bit 7	Bit 6	Bit 5	Bit 4	Bit 3	Bit 2	Bit 1	Bit 0
0x00D8	SPICR1	R	SPIE	SPE	SPTIE	MSTR	CPOL	CPHA	SSOE	LSBFE
		W								
0x00D9	SPICR2	R	0	0	0	MODFEN	BIDIROE	0	SPISWAI	SPC0
		W								
0x00DA	SPIBR	R	0	SPPR2	SPPR1	SPPR0	0	SPR2	SPR1	SPR0
		W								
0x00DB	SPISR	R	SPIF	0	SPTEF	MODF	0	0	0	0
		W								
0x00DC	Reserved	R	0	0	0	0	0	0	0	0
		W								
0x00DD	SPIDR	R	Bit7	6	5	4	3	2	1	Bit0
		W								
0x00DE	Reserved	R	0	0	0	0	0	0	0	0
		W								
0x00DF	Reserved	R	0	0	0	0	0	0	0	0
		W								

0x00E0 – 0x00E7 IIC (Inter-IC Bus)

Address	Name		Bit 7	Bit 6	Bit 5	Bit 4	Bit 3	Bit 2	Bit 1	Bit 0
0x00E0	IBAD	R	ADR7	ADR6	ADR5	ADR4	ADR3	ADR2	ADR1	0
		W								
0x00E1	IBFD	R	IBC7	IBC6	IBC5	IBC4	IBC3	IBC2	IBC1	IBC0
		W								
0x00E2	IBCR	R	IBEN	IBIE	MS/SL	Tx/Rx	TXAK	0	0	IBSWAI
		W						RSTA		
0x00E3	IBSR	R	TCF	IAAS	IBB	IBAL	0	SRW	IBIF	RXAK
		W								

0x00E0 – 0x00E7 IIC (Inter-IC Bus) (continued)

Address	Name		Bit 7	Bit 6	Bit 5	Bit 4	Bit 3	Bit 2	Bit 1	Bit 0
0x00E4	IBDR	R	D7	D6	D5	D4	D3	D2	D1	D0
		W								
0x00E5	Reserved	R	0	0	0	0	0	0	0	0
		W								
0x00E6	Reserved	R	0	0	0	0	0	0	0	0
		W								
0x00E7	Reserved	R	0	0	0	0	0	0	0	0
		W								

0x00E8 – 0x00EF SCI2 (Asynchronous Serial Interface)

Address	Name		Bit 7	Bit 6	Bit 5	Bit 4	Bit 3	Bit 2	Bit 1	Bit 0
0x00E8	SCIBDH	R	IREN	TNP1	TNP0	SBR12	SBR11	SBR10	SBR9	SBR8
		W								
0x00E9	SCIBDL	R	SBR7	SBR6	SBR5	SBR4	SBR3	SBR2	SBR1	SBR0
		W								
0x00EA	SCICR1	R	LOOPS	SCISWAI	RSRC	M	WAKE	ILT	PE	PT
		W								
0x00EB	SCICR2	R	TIE	TCIE	RIE	ILIE	TE	RE	RWU	SBK
		W								
0x00EC	SCISR1	R	TDRE	TC	RDRF	IDLE	OR	NF	FE	PF
		W								
0x00ED	SCISR2	R	0	0	0	TXPOL ¹	RXPOL ¹	BRK13	TXDIR	RAF
		W								
0x00EE	SCIDRH	R	R8	T8	0	0	0	0	0	0
		W								
0x00EF	SCIDRL	R	R7	R6	R5	R4	R3	R2	R1	R0
		W	T7	T6	T5	T4	T3	T2	T1	T0

¹ TXPOL and RXPOL are available in version V04 of SCI

0x00F0 – 0x00F3 DAC0 (Digital-to-Analog Converter)

Address	Name		Bit 7	Bit 6	Bit 5	Bit 4	Bit 3	Bit 2	Bit 1	Bit 0
0x00F0	DACCO	R	DACE	DACTE	0	0	DJM	DSGN	DACWAI	DACOE
		W								
0x00F1	DACCC1	R	0	0	0	0	0	0	0	0
		W								
0x00F2	DACD	R	BIT7	BIT6	BIT5	BIT4	BIT3	BIT2	BIT1	BIT0
		W								
0x00F3	DACD	R	BIT7	BIT6	BIT5	BIT4	BIT3	BIT2	BIT1	BIT0
		W								

0x00F4 – 0x00F7 DAC1 (Digital-to-Analog Converter)

Address	Name		Bit 7	Bit 6	Bit 5	Bit 4	Bit 3	Bit 2	Bit 1	Bit 0
0x00F4	DACCO	R	DACE	DACTE	0	0	DJM	DSGN	DACWAI	DACOE
		W								
0x00F5	DACCC1	R	0	0	0	0	0	0	0	0
		W								
0x00F6	DACD	R	BIT7	BIT6	BIT5	BIT4	BIT3	BIT2	BIT1	BIT0
		W								
0x00F7	DACD	R	BIT7	BIT6	BIT5	BIT4	BIT3	BIT2	BIT1	BIT0
		W								

0x00F8 – 0x00FF Reserved

Address	Name		Bit 7	Bit 6	Bit 5	Bit 4	Bit 3	Bit 2	Bit 1	Bit 0
0x00F8– 0x00FF	Reserved	R	0	0	0	0	0	0	0	0
		W								

0x0100 – 0x010F Flash Control Register

Address	Name		Bit 7	Bit 6	Bit 5	Bit 4	Bit 3	Bit 2	Bit 1	Bit 0
0x0100	FCLKDIV	R	FDIVLD	PRDIV8	FDIV5	FDIV4	FDIV3	FDIV2	FDIV1	FDIV0
		W								
0x0101	FSEC	R	KEYEN1	NV6	NV5	NV4	NV3	NV2	SEC1	SEC0
		W								
0x0102	Reserved for Factory Test	R	0	0	0	0	0	0	0	0
		W								
0x0103	FCNFG	R	CBEIE	CCIE	KEYACC	0	0	0	0	0
		W								
0x0104	FPROT	R	FPOPEN	NV6	FPHDIS	FPHS1	FPHS0	FPLDIS	FPLS1	FPLS0
		W								

0x0100 – 0x010F Flash Control Register (continued)

Address	Name		Bit 7	Bit 6	Bit 5	Bit 4	Bit 3	Bit 2	Bit 1	Bit 0
0x0105	FSTAT	R	CBEIF	CCIF	PVIOL	ACCERR	0	BLANK	0	0
		W								
0x0106	FCMD	R	0	CMDB6	CMDB5	0	0	CMDB2	0	CMDB0
		W								
0x0107	Reserved for Factory Test	R	0	0	0	0	0	0	0	0
		W								
0x0108	Reserved for Factory Test	R	0	0	0	0	0	0	0	0
		W								
0x0109	Reserved for Factory Test	R	0	0	0	0	0	0	0	0
		W								
0x010A	Reserved for Factory Test	R	0	0	0	0	0	0	0	0
		W								
0x010B	Reserved for Factory Test	R	0	0	0	0	0	0	0	0
		W								
0x010C	Reserved	R	0	0	0	0	0	0	0	0
		W								
0x010D	Reserved	R	0	0	0	0	0	0	0	0
		W								
0x010E	Reserved	R	0	0	0	0	0	0	0	0
		W								
0x010F	Reserved	R	0	0	0	0	0	0	0	0
		W								

0x0110 – 0x013F Reserved

Address	Name		Bit 7	Bit 6	Bit 5	Bit 4	Bit 3	Bit 2	Bit 1	Bit 0
0x0110– 0x013F	Reserved	R	0	0	0	0	0	0	0	0
		W								

0x0140 – 0x016F TIM1 (Timer 16 Bit 4 Channels) (Sheet 1 of 4)

Address	Name		Bit 7	Bit 6	Bit 5	Bit 4	Bit 3	Bit 2	Bit 1	Bit 0
0x0140	TIOS	R	IOS7	IOS6	IOS5	IOS4	0	0	0	0
		W								
0x0141	CFORC	R	0	0	0	0	0	0	0	0
		W	FOC7	FOC6	FOC5	FOC4				
0x0142	OC7M	R	OC7M7	OC7M6	OC7M5	OC7M4	0	0	0	0
		W								
0x0143	OC7D	R	OC7D7	OC7D6	OC7D5	OC7D4	0	0	0	0
		W								

0x0140 – 0x016F TIM1 (Timer 16 Bit 4 Channels) (Sheet 2 of 4)

Address	Name		Bit 7	Bit 6	Bit 5	Bit 4	Bit 3	Bit 2	Bit 1	Bit 0
0x0144	TCNT (hi)	R	Bit 15	14	13	12	11	10	9	Bit 8
		W								
0x0145	TCNT (lo)	R	Bit 7	6	5	4	3	2	1	Bit 0
		W								
0x0146	TSCR1	R	TEN	TSWAI	TSFRZ	TFFCA	0	0	0	0
		W								
0x0147	TTOV	R	TOV7	TOV6	TOV5	TOV4	0	0	0	0
		W								
0x0148	TCTL1	R	OM7	OL7	OM6	OL6	OM5	OL5	OM4	OL4
		W								
0x0149	Reserved	R	0	0	0	0	0	0	0	0
		W								
0x014A	TCTL3	R	EDG7B	EDG7A	EDG6B	EDG6A	EDG5B	EDG5A	EDG4B	EDG4A
		W								
0x014B	Reserved	R	0	0	0	0	0	0	0	0
		W								
0x014C	TIE	R	C7I	C6I	C5I	C4I	0	0	0	0
		W								
0x014D	TSCR2	R	TOI	0	0	0	TCRE	PR2	PR1	PR0
		W								
0x014E	TFLG1	R	C7F	C6F	C5F	C4F	0	0	0	0
		W								
0x014F	TFLG2	R	TOF	0	0	0	0	0	0	0
		W								
0x0150	Reserved	R	0	0	0	0	0	0	0	0
		W								
0x0151	Reserved	R	0	0	0	0	0	0	0	0
		W								
0x0152	Reserved	R	0	0	0	0	0	0	0	0
		W								
0x0153	Reserved	R	0	0	0	0	0	0	0	0
		W								
0x0154	Reserved	R	0	0	0	0	0	0	0	0
		W								
0x0155	Reserved	R	0	0	0	0	0	0	0	0
		W								
0x0156	Reserved	R	0	0	0	0	0	0	0	0
		W								

0x0140 – 0x016F TIM1 (Timer 16 Bit 4 Channels) (Sheet 3 of 4)

Address	Name		Bit 7	Bit 6	Bit 5	Bit 4	Bit 3	Bit 2	Bit 1	Bit 0
0x0157	Reserved	R	0	0	0	0	0	0	0	0
		W								
0x0158	TC4 (hi)	R	Bit 15	14	13	12	11	10	9	Bit 8
		W								
0x0159	TC4 (lo)	R	Bit 7	6	5	4	3	2	1	Bit 0
		W								
0x015A	TC5 (hi)	R	Bit 15	14	13	12	11	10	9	Bit 8
		W								
0x015B	TC5 (lo)	R	Bit 7	6	5	4	3	2	1	Bit 0
		W								
0x015C	TC6 (hi)	R	Bit 15	14	13	12	11	10	9	Bit 8
		W								
0x015D	TC6 (lo)	R	Bit 7	6	5	4	3	2	1	Bit 0
		W								
0x015E	TC7 (hi)	R	Bit 15	14	13	12	11	10	9	Bit 8
		W								
0x015F	TC7 (lo)	R	Bit 7	6	5	4	3	2	1	Bit 0
		W								
0x0160	PACTL	R	0							
		W		PAEN	PAMOD	PEDGE	CLK1	CLK0	PAOVI	PAI
0x0161	PAFLG	R	0	0	0	0	0	0		
		W							PAOVF	PAIF
0x0162	PACNT (hi)	R	Bit 15	14	13	12	11	10	9	Bit 8
		W								
0x0163	PACNT (lo)	R	Bit 7	6	5	4	3	2	1	Bit 0
		W								
0x0164	Reserved	R	0	0	0	0	0	0	0	0
		W								
0x0165	Reserved	R	0	0	0	0	0	0	0	0
		W								
0x0166	Reserved	R	0	0	0	0	0	0	0	0
		W								
0x0167	Reserved	R	0	0	0	0	0	0	0	0
		W								
0x0168	Reserved	R	0	0	0	0	0	0	0	0
		W								
0x0169	Reserved	R	0	0	0	0	0	0	0	0
		W								

0x0140 – 0x016F TIM1 (Timer 16 Bit 4 Channels) (Sheet 4 of 4)

Address	Name		Bit 7	Bit 6	Bit 5	Bit 4	Bit 3	Bit 2	Bit 1	Bit 0
0x016A	Reserved	R	0	0	0	0	0	0	0	0
		W								
0x016B	Reserved	R	0	0	0	0	0	0	0	0
		W								
0x016C	Reserved	R	0	0	0	0	0	0	0	0
		W								
0x016D	Reserved	R	0	0	0	0	0	0	0	0
		W								
0x016E	Reserved	R	0	0	0	0	0	0	0	0
		W								
0x016F	Reserved	R	0	0	0	0	0	0	0	0
		W								

0x0170 – 0x017F Reserved

Address	Name		Bit 7	Bit 6	Bit 5	Bit 4	Bit 3	Bit 2	Bit 1	Bit 0
0x0110– 0x013F	Reserved	R	0	0	0	0	0	0	0	0
		W								

0x0180 – 0x01AF TIM2 (Timer 16 Bit 4 Channels) (Sheet 1 of 3)

Address	Name		Bit 7	Bit 6	Bit 5	Bit 4	Bit 3	Bit 2	Bit 1	Bit 0
0x0180	TIOS	R	IOS7	IOS6	IOS5	IOS4	0	0	0	0
		W								
0x0181	CFORC	R	0	0	0	0	0	0	0	0
		W	FOC7	FOC6	FOC5	FOC4				
0x0182	OC7M	R	OC7M7	OC7M6	OC7M5	OC7M4	0	0	0	0
		W								
0x0183	OC7D	R	OC7D7	OC7D6	OC7D5	OC7D4	0	0	0	0
		W								
0x0184	TCNT (hi)	R	Bit 15	14	13	12	11	10	9	Bit 8
		W								
0x0185	TCNT (lo)	R	Bit 7	6	5	4	3	2	1	Bit 0
		W								
0x0186	TSCR1	R	TEN	TSWAI	TSFRZ	TFFCA	0	0	0	0
		W								
0x0187	TTOV	R	TOV7	TOV6	TOV5	TOV4	0	0	0	0
		W								
0x0188	TCTL1	R	OM7	OL7	OM6	OL6	OM5	OL5	OM4	OL4
		W								

0x0180 – 0x01AF TIM2 (Timer 16 Bit 4 Channels) (Sheet 2 of 3)

Address	Name		Bit 7	Bit 6	Bit 5	Bit 4	Bit 3	Bit 2	Bit 1	Bit 0
0x0189	Reserved	R	0	0	0	0	0	0	0	0
		W								
0x018A	TCTL3	R	EDG7B	EDG7A	EDG6B	EDG6A	EDG5B	EDG5A	EDG4B	EDG4A
		W								
0x018B	Reserved	R	0	0	0	0	0	0	0	0
		W								
0x018C	TIE	R	C7I	C6I	C5I	C4I	0	0	0	0
		W								
0x018D	TSCR2	R	TOI	0	0	0	TCRE	PR2	PR1	PR0
		W								
0x018E	TFLG1	R	C7F	C6F	C5F	C4F	0	0	0	0
		W								
0x018F	TFLG2	R	TOF	0	0	0	0	0	0	0
		W								
0x0190	Reserved	R	0	0	0	0	0	0	0	0
		W								
0x0191	Reserved	R	0	0	0	0	0	0	0	0
		W								
0x0192	Reserved	R	0	0	0	0	0	0	0	0
		W								
0x0193	Reserved	R	0	0	0	0	0	0	0	0
		W								
0x0194	Reserved	R	0	0	0	0	0	0	0	0
		W								
0x0195	Reserved	R	0	0	0	0	0	0	0	0
		W								
0x0196	Reserved	R	0	0	0	0	0	0	0	0
		W								
0x0197	Reserved	R	0	0	0	0	0	0	0	0
		W								
0x0198	TC4 (hi)	R	Bit 15	14	13	12	11	10	9	Bit 8
		W								
0x0199	TC4 (lo)	R	Bit 7	6	5	4	3	2	1	Bit 0
		W								
0x015A	TC5 (hi)	R	Bit 15	14	13	12	11	10	9	Bit 8
		W								
0x019B	TC5 (lo)	R	Bit 7	6	5	4	3	2	1	Bit 0
		W								
0x019C	TC6 (hi)	R	Bit 15	14	13	12	11	10	9	Bit 8
		W								

0x0180 – 0x01AF TIM2 (Timer 16 Bit 4 Channels) (Sheet 3 of 3)

Address	Name		Bit 7	Bit 6	Bit 5	Bit 4	Bit 3	Bit 2	Bit 1	Bit 0
0x019D	TC6 (lo)	R W	Bit 7	6	5	4	3	2	1	Bit 0
0x019E	TC7 (hi)	R W	Bit 15	14	13	12	11	10	9	Bit 8
0x019F	TC7 (lo)	R W	Bit 7	6	5	4	3	2	1	Bit 0
0x01A0	PACTL	R W	0	PAEN	PAMOD	PEDGE	CLK1	CLK0	PAOVI	PAI
0x01A1	PAFLG	R W	0	0	0	0	0	0	PAOVF	PAIF
0x01A2	PACNT (hi)	R W	Bit 15	14	13	12	11	10	9	Bit 8
0x01A3	PACNT (lo)	R W	Bit 7	6	5	4	3	2	1	Bit 0
0x01A4	Reserved	R W	0	0	0	0	0	0	0	0
0x01A5	Reserved	R W	0	0	0	0	0	0	0	0
0x01A6	Reserved	R W	0	0	0	0	0	0	0	0
0x01A7	Reserved	R W	0	0	0	0	0	0	0	0
0x01A8	Reserved	R W	0	0	0	0	0	0	0	0
0x01A9	Reserved	R W	0	0	0	0	0	0	0	0
0x01AA	Reserved	R W	0	0	0	0	0	0	0	0
0x01AB	Reserved	R W	0	0	0	0	0	0	0	0
0x01AC	Reserved	R W	0	0	0	0	0	0	0	0
0x01AD	Reserved	R W	0	0	0	0	0	0	0	0
0x01AE	Reserved	R W	0	0	0	0	0	0	0	0
0x01AF	Reserved	R W	0	0	0	0	0	0	0	0

0x01B0 – 0x01DF Reserved

Address	Name		Bit 7	Bit 6	Bit 5	Bit 4	Bit 3	Bit 2	Bit 1	Bit 0
0x01B0– 0x01DF	Reserved	R	0	0	0	0	0	0	0	0
		W								

0x01E0 – 0x01FF PWM (Pulse Width Modulator)

Address	Name		Bit 7	Bit 6	Bit 5	Bit 4	Bit 3	Bit 2	Bit 1	Bit 0
0x01E0	PWME	R	0	0	PWME5	PWME4	PWME3	PWME2	PWME1	PWME0
		W								
0x01E1	PWMPOL	R	0	0	PPOL5	PPOL4	PPOL3	PPOL2	PPOL1	PPOL0
		W								
0x01E2	PWMCLK	R	0	0	PCLK5	PCLK4	PCLK3	PCLK2	PCLK1	PCLK0
		W								
0x01E3	PWMPRCLK	R	0	PCKB2	PCKB1	PCKB0	0	PCKA2	PCKA1	PCKA0
		W								
0x01E4	PWMCAE	R	0	0	CAE5	CAE4	CAE3	CAE2	CAE1	CAE0
		W								
0x01E5	PWMCTL	R	0	CON45	CON23	CON01	PSWAI	PFRZ	0	0
		W								
0x01E6	PWMSTST Test Only	R	0	0	0	0	0	0	0	0
		W								
0x01E7	PWMPRSC	R	0	0	0	0	0	0	0	0
		W								
0x01E8	PWMSCLA	R	Bit 7	6	5	4	3	2	1	Bit 0
		W								
0x01E9	PWMSCLB	R	Bit 7	6	5	4	3	2	1	Bit 0
		W								
0x01EA	PWMSCNTA	R	0	0	0	0	0	0	0	0
		W								
0x01EB	PWMSCNTB	R	0	0	0	0	0	0	0	0
		W								
0x01EC	PWMCNT0	R	Bit 7	6	5	4	3	2	1	Bit 0
		W	0	0	0	0	0	0	0	0
0x01ED	PWMCNT1	R	Bit 7	6	5	4	3	2	1	Bit 0
		W	0	0	0	0	0	0	0	0
0x01EE	PWMCNT2	R	Bit 7	6	5	4	3	2	1	Bit 0
		W	0	0	0	0	0	0	0	0
0x01EF	PWMCNT3	R	Bit 7	6	5	4	3	2	1	Bit 0
		W	0	0	0	0	0	0	0	0

0x01E0 – 0x01FF PWM (Pulse Width Modulator) (continued)

Address	Name		Bit 7	Bit 6	Bit 5	Bit 4	Bit 3	Bit 2	Bit 1	Bit 0
0x01F0	PWMCNT4	R	Bit 7	6	5	4	3	2	1	Bit 0
		W	0	0	0	0	0	0	0	0
0x01F1	PWMCNT5	R	Bit 7	6	5	4	3	2	1	Bit 0
		W	0	0	0	0	0	0	0	0
0x01F2	PWMPER0	R	Bit 7	6	5	4	3	2	1	Bit 0
		W								
0x01F3	PWMPER1	R	Bit 7	6	5	4	3	2	1	Bit 0
		W								
0x01F4	PWMPER2	R	Bit 7	6	5	4	3	2	1	Bit 0
		W								
0x01F5	PWMPER3	R	Bit 7	6	5	4	3	2	1	Bit 0
		W								
0x01F6	PWMPER4	R	Bit 7	6	5	4	3	2	1	Bit 0
		W								
0x01F7	PWMPER5	R	Bit 7	6	5	4	3	2	1	Bit 0
		W								
0x01F8	PWMDTY0	R	Bit 7	6	5	4	3	2	1	Bit 0
		W								
0x01F9	PWMDTY1	R	Bit 7	6	5	4	3	2	1	Bit 0
		W								
0x01FA	PWMDTY2	R	Bit 7	6	5	4	3	2	1	Bit 0
		W								
0x01FB	PWMDTY3	R	Bit 7	6	5	4	3	2	1	Bit 0
		W								
0x01FC	PWMDTY4	R	Bit 7	6	5	4	3	2	1	Bit 0
		W								
0x01FD	PWMDTY5	R	Bit 7	6	5	4	3	2	1	Bit 0
		W								
0x01FE	PWMSDN	R	PWMIF	PWMIE	0	PWMLVL	0	PWM5IN	PWM5INL	PWM5ENA
		PWMRSTRT								
0x01FF	Reserved	R	0	0	0	0	0	0	0	0
		W								

0x0200 – 0x023F PMF (Pulse width Modulator with Fault protection) (Sheet 1 of 4)

Address	Name		Bit 7	Bit 6	Bit 5	Bit 4	Bit 3	Bit 2	Bit 1	Bit 0
0x0200	PMFCFG0	R W	WP	MTG	EDGE C	EDGE B	EDGE A	INDEPC	INDEPB	INDEPA
0x0201	PMFCFG1	R W	ENHA	0	BOTNEGC	TOPNEGC	BOTNEGB	TOPNEGB	BOTNEGA	TOPNEGA
0x0202	PMFCFG2	R W	0	0	MSK5	MSK4	MSK3	MSK2	MSK1	MSK0
0x0203	PMFCFG3	R W	PMFWAI	PMFFRZ	0	VLMODE		SWAPC	SWAPB	SWAPA
0x0204	PMFFCTL	R W	FMODE3	FIE3	FMODE2	FIE2	FMODE1	FIE1	FMODE0	FIE0
0x0205	PMFFPIN	R W	0	FPINE3	0	FPINE2	0	FPINE1	0	FPINE0
0x0206	PMFFSTA	R W	0	FFLAG3	0	FFLAG2	0	FFLAG1	0	FFLAG0
0x0207	PMFQSMP	R W	QSMP3		QSMP2		QSMP1		QSMP0	
0x0208	PMFDMPA	R W	DMP13	DMP12	DMP11	DMP10	DMP03	DMP02	DMP01	DMP00
0x0209	PMFDMPB	R W	DMP33	DMP32	DMP31	DMP30	DMP23	DMP22	DMP21	DMP20
0x020A	PMFDMPC	R W	DMP53	DMP52	DMP51	DMP50	DMP43	DMP42	DMP41	DMP40
0x020B	Reserved	R W	0	0	0	0	0	0	0	0
0x020C	PMFOUTC	R W	0	0	OUTCTL5	OUTCTL4	OUTCTL3	OUTCTL2	OUTCTL1	OUTCTL0
0x020D	PMFOUTB	R W	0	0	OUT5	OUT4	OUT3	OUT2	OUT1	OUT0
0x020E	PMFDTMS	R W	0	0	DT5	DT4	DT3	DT2	DT1	DT0
0x020F	PMFCCTL	R W	0	0	ISENS		0	IPOLC	IPOLB	IPOLA
0x0210	PMFVAL0	R W	Bit 15	14	13	12	11	10	9	Bit 8
0x0211	PMFVAL0	R W	Bit 7	6	5	4	3	2	1	Bit 0
0x0212	PMFVAL1	R W	Bit 15	14	13	12	11	10	9	Bit 8

0x0200 – 0x023F PMF (Pulse width Modulator with Fault protection) (Sheet 2 of 4)

Address	Name		Bit 7	Bit 6	Bit 5	Bit 4	Bit 3	Bit 2	Bit 1	Bit 0
0x0213	PMFVAL1	R	Bit 7	6	5	4	3	2	1	Bit 0
		W								
0x0214	PMFVAL2	R	Bit 15	14	13	12	11	10	9	Bit 8
		W								
0x0215	PMFVAL2	R	Bit 7	6	5	4	3	2	1	Bit 0
		W								
0x0216	PMFVAL3	R	Bit 15	14	13	12	11	10	9	Bit 8
		W								
0x0217	PMFVAL3	R	Bit 7	6	5	4	3	2	1	Bit 0
		W								
0x0218	PMFVAL4	R	Bit 15	14	13	12	11	10	9	Bit 8
		W								
0x0219	PMFVAL4	R	Bit 7	6	5	4	3	2	1	Bit 0
		W								
0x021A	PMFVAL5	R	Bit 15	14	13	12	11	10	9	Bit 8
		W								
0x021B	PMFVAL5	R	Bit 7	6	5	4	3	2	1	Bit 0
		W								
0x021C	Reserved	R	0	0	0	0	0	0	0	0
		W								
0x021D	Reserved	R	0	0	0	0	0	0	0	0
		W								
0x021E	Reserved	R	0	0	0	0	0	0	0	0
		W								
0x021F	Reserved	R	0	0	0	0	0	0	0	0
		W								
0x0220	PMFENCA	R	PWMENA	0	0	0	0	0	LDOKA	PWMRIEA
		W								
0x0221	PMFFQCA	R	LDFQA				HALFA	PRSCA		PWMRFA
		W								
0x0222	PMFCNTA	R	0	Bit 14	13	12	11	10	9	Bit 8
		W								
0x0223	PMFCNTA	R	Bit 7	6	5	4	3	2	1	Bit 0
		W								
0x0224	PMFMODA	R	0	Bit 14	13	12	11	10	9	Bit 8
		W								
0x0225	PMFMODA	R	Bit 7	6	5	4	3	2	1	Bit 0
		W								

0x0200 – 0x023F PMF (Pulse width Modulator with Fault protection) (Sheet 3 of 4)

Address	Name		Bit 7	Bit 6	Bit 5	Bit 4	Bit 3	Bit 2	Bit 1	Bit 0
0x0226	PMFDTMA	R	0	0	0	0	Bit 11	10	9	Bit 8
		W								
0x0227	PMFDTMA	R	Bit 7	6	5	4	3	2	1	Bit 0
		W								
0x0228	PMFENCB	R	PWMENB	0	0	0	0	0	LDOKB	PWMRIEB
		W								
0x0229	PMFFQCB	R	LDFQB				HALFB	PRSCB		PWMRFB
		W								
0x022A	PMFCNTB	R	0	Bit 14	13	12	11	10	9	Bit 8
		W								
0x022B	PMFCNTB	R	Bit 7	6	5	4	3	2	1	Bit 0
		W								
0x022C	PMFMODB	R	0	Bit 14	13	12	11	10	9	Bit 8
		W								
0x022D	PMFMODB	R	Bit 7	6	5	4	3	2	1	Bit 0
		W								
0x022E	PMFDTMB	R	0	0	0	0	Bit 11	10	9	Bit 8
		W								
0x022F	PMFDTMB	R	Bit 7	6	5	4	3	2	1	Bit 0
		W								
0x0230	PMFENCC	R	PWMENC	0	0	0	0	0	LDOKC	PWMRIEC
		W								
0x0231	PMFFQCC	R	LDFQC				HALFC	PRSCC		PWMRFC
		W								
0x0232	PMFCNTC	R	0	Bit 14	13	12	11	10	9	Bit 8
		W								
0x0233	PMFCNTC	R	Bit 7	6	5	4	3	2	1	Bit 0
		W								
0x0234	PMFMODC	R	0	Bit 14	13	12	11	10	9	Bit 8
		W								
0x0235	PMFMODC	R	Bit 7	6	5	4	3	2	1	Bit 0
		W								
0x0236	PMFDTMC	R	0	0	0	0	Bit 11	10	9	Bit 8
		W								
0x0237	PMFDTMC	R	Bit 7	6	5	4	3	2	1	Bit 0
		W								
0x0238	Reserved	R	0	0	0	0	0	0	0	0
		W								

0x0200 – 0x023F PMF (Pulse width Modulator with Fault protection) (Sheet 4 of 4)

Address	Name		Bit 7	Bit 6	Bit 5	Bit 4	Bit 3	Bit 2	Bit 1	Bit 0
0x0239	Reserved	R	0	0	0	0	0	0	0	0
		W								
0x023A	Reserved	R	0	0	0	0	0	0	0	0
		W								
0x023B	Reserved	R	0	0	0	0	0	0	0	0
		W								
0x023C	Reserved	R	0	0	0	0	0	0	0	0
		W								
0x023D	Reserved	R	0	0	0	0	0	0	0	0
		W								
0x023E	Reserved	R	0	0	0	0	0	0	0	0
		W								
0x023F	Reserved	R	0	0	0	0	0	0	0	0
		W								

0x0240 – 0x027F PIM (Port Interface Module) (Sheet 1 of 4)

Address	Name		Bit 7	Bit 6	Bit 5	Bit 4	Bit 3	Bit 2	Bit 1	Bit 0
0x0240	PTT	R								
		W	PTT7	PTT6	PTT5	PTT4	PTT3	PTT2	PTT1	PTT0
0x0241	PTIT	R	PTIT7	PTIT6	PTIT5	PTIT4	PTIT3	PTIT2	PTIT1	PTIT0
		W								
0x0242	DDRT	R								
		W	DDRT7	DDRT6	DDRT5	DDRT4	DDRT3	DDRT2	DDRT1	DDRT0
0x0243	RDRT	R								
		W	RDRT7	RDRT6	RDRT5	RDRT4	RDRT3	RDRT2	RDRT1	RDRT0
0x0244	PERT	R								
		W	PERT7	PERT6	PERT5	PERT4	PERT3	PERT2	PERT1	PERT0
0x0245	PPST	R								
		W	PPST7	PPST6	PPST5	PPST4	PPST3	PPST2	PPST1	PPST0
0x0246	Reserved	R	0	0	0	0	0	0	0	0
		W								
0x0247	Reserved	R	0	0	0	0	0	0	0	0
		W								
0x0248	PTS	R								
		W	PTS7	PTS6	PTS5	PTS4	PTS3	PTS2	PTS1	PTS0
0x0249	PTIS	R	PTIS7	PTIS6	PTIS5	PTIS4	PTIS3	PTIS2	PTIS1	PTIS0
		W								

0x0240 – 0x027F PIM (Port Interface Module) (Sheet 2 of 4)

Address	Name		Bit 7	Bit 6	Bit 5	Bit 4	Bit 3	Bit 2	Bit 1	Bit 0
0x024A	DDRS	R	DDRS7	DDRS6	DDRS5	DDRS4	DDRS3	DDRS2	DDRS1	DDRS0
		W								
0x024B	RDRS	R	RDRS7	RDRS6	RDRS5	RDRS4	RDRS3	RDRS2	RDRS1	RDRS0
		W								
0x024C	PERS	R	PERS7	PERS6	PERS5	PERS4	PERS3	PERS2	PERS1	PERS0
		W								
0x024D	PPSS	R	PPSS7	PPSS6	PPSS5	PPSS4	PPSS3	PPSS2	PPSS1	PPSS0
		W								
0x024E	WOMS	R	WOMS7	WOMS6	WOMS5	WOMS4	WOMS3	WOMS2	WOMS1	WOMS0
		W								
0x024F	Reserved	R	0	0	0	0	0	0	0	0
		W								
0x0250	PTM	R	PTM7	PTM6	PTM5	PTM4	PTM3	0	PTM1	PTM0
		W								
0x0251	PTIM	R	PTIM7	PTIM6	PTIM5	PTIM4	PTIM3	0	PTIM1	PTIM0
		W								
0x0252	DDRM	R	DDRM7	DDRM6	DDRM5	DDRM4	DDRM3	0	DDRM1	DDRM0
		W								
0x0253	RDRM	R	RDRM7	RDRM6	RDRM5	RDRM4	RDRM3	0	RDRM1	RDRM0
		W								
0x0254	PERM	R	PERM7	PERM6	PERM5	PERM4	PERM3	0	PERM1	PERM0
		W								
0x0255	PPSM	R	PPSM7	PPSM6	PPSM5	PPSM4	PPSM3	0	PPSM1	PPSM0
		W								
0x0256	WOMM	R	WOMM7	WOMM6	WOMM5	WOMM4	0	0	0	0
		W								
0x0257	Reserved	R	0	0	0	0	0	0	0	0
		W								
0x0258	PTP	R	0	0	PTP5	PTP4	PTP3	PTP2	PTP1	PTP0
		W								
0x0259	PTIP	R	0	0	PTIP5	PTIP4	PTIP3	PTIP2	PTIP1	PTIP0
		W								
0x025A	DDRP	R	0	0	DDRP5	DDRP4	DDRP3	DDRP2	DDRP1	DDRP0
		W								
0x025B	RDRP	R	0	0	RDRP5	RDRP4	RDRP3	RDRP2	RDRP1	RDRP0
		W								
0x025C	PERP	R	0	0	PERP5	PERP4	PERP3	PERP2	PERP1	PERP0
		W								

0x0240 – 0x027F PIM (Port Interface Module) (Sheet 3 of 4)

Address	Name		Bit 7	Bit 6	Bit 5	Bit 4	Bit 3	Bit 2	Bit 1	Bit 0
0x025D	PPSP	R	0	0	PPSP5	PPSP4	PPSP3	PPSP2	PPSP1	PPSP0
		W								
0x025E	Reserved	R	0	0	0	0	0	0	0	0
		W								
0x025F	Reserved	R	0	0	0	0	0	0	0	0
		W								
0x0260	PTQ	R	0	PTQ6	PTQ5	PTQ4	PTQ3	PTQ2	PTQ1	PTQ0
		W								
0x0261	PTIQ	R	0	PTIQ6	PTIQ5	PTIQ4	PTIQ3	PTIQ2	PTIQ1	PTIQ0
		W								
0x0262	DDRQ	R	0	DDRQ6	DDRQ5	DDRQ4	DDRQ3	DDRQ2	DDRQ1	DDRQ0
		W								
0x0263	RDRQ	R	0	RDRQ6	RDRQ5	RDRQ4	RDRQ3	RDRQ2	RDRQ1	RDRQ0
		W								
0x0264	PERQ	R	0	PERQ6	PERQ5	PERQ4	PERQ3	PERQ2	PERQ1	PERQ0
		W								
0x0265	PPSQ	R	0	PPSQ6	PPSQ5	PPSQ4	PPSQ3	PPSQ2	PPSQ1	PPSQ0
		W								
0x0266	Reserved	R	0	0	0	0	0	0	0	0
		W								
0x0267	Reserved	R	0	0	0	0	0	0	0	0
		W								
0x0268	PTU	R	PTU7	PTU6	PTU5	PTU4	PTU3	PTU2	PTU1	PTU0
		W								
0x0269	PTIU	R	PTIU7	PTIU6	PTIU5	PTIU4	PTIU3	PTIU2	PTIU1	PTIU0
		W								
0x026A	DDRU	R	DDRU7	DDRU6	DDRU5	DDRU4	DDRU3	DDRU2	DDRU1	DDRU0
		W								
0x026B	RDRU	R	RDRU7	RDRU6	RDRU5	RDRU4	RDRU3	RDRU2	RDRU1	RDRU0
		W								
0x026C	PERU	R	PERU7	PERU6	PERU5	PERU4	PERU3	PERU2	PERU1	PERU0
		W								
0x026D	PPSU	R	PPSU7	PPSU6	PPSU5	PPSU4	PPSU3	PPSU2	PPSU1	PPSU0
		W								
0x026E	MODRR	R	0	0	0	0	MODRR3	MODRR2	MODRR1	MODRR0
		W								
0x026F	Reserved	R	0	0	0	0	0	0	0	0
		W								

0x0240 – 0x027F PIM (Port Interface Module) (Sheet 4 of 4)

Address	Name		Bit 7	Bit 6	Bit 5	Bit 4	Bit 3	Bit 2	Bit 1	Bit 0
0x0270	PTAD(H)	R	PTAD15	PTAD14	PTAD13	PTAD12	PTAD11	PTAD10	PTAD9	PTAD8
		W								
0x0271	PTAD(L)	R	PTAD7	PTAD6	PTAD5	PTAD4	PTAD3	PTAD2	PTAD1	PTAD0
		W								
0x0272	PTIAD(H)	R	PTIAD15	PTIAD14	PTIAD13	PTIAD12	PTIAD11	PTIAD10	PTIAD9	PTIAD8
		W								
0x0273	PTIAD(L)	R	PTIAD7	PTIAD6	PTIAD5	PTIAD4	PTIAD3	PTIAD2	PTIAD1	PTIAD0
		W								
0x0274	DDRAD(H)	R	DDRAD15	DDRAD14	DDRAD13	DDRAD12	DDRAD11	DDRAD10	DDRAD9	DDRAD8
		W								
0x0275	DDRAD(L)	R	DDRAD7	DDRAD6	DDRAD5	DDRAD4	DDRAD3	DDRAD2	DDRAD1	DDRAD0
		W								
0x0276	RDRAD(H)	R	RDRAD15	RDRAD14	RDRAD13	RDRAD12	RDRAD11	RDRAD10	RDRAD9	RDRAD8
		W								
0x0277	RDRAD(L)	R	RDRAD7	RDRAD6	RDRAD5	RDRAD4	RDRAD3	RDRAD2	RDRAD1	RDRAD0
		W								
0x0278	PERAD(H)	R	PERAD15	PERAD14	PERAD13	PERAD12	PERAD11	PERAD10	PERAD9	PERAD8
		W								
0x0279	PERAD(L)	R	PERAD7	PERAD6	PERAD5	PERAD4	PERAD3	PERAD2	PERAD1	PERAD0
		W								
0x027A	PPSAD(H)	R	PPSAD15	PPSAD14	PPSAD13	PPSAD12	PPSAD11	PPSAD10	PPSAD9	PPSAD8
		W								
0x027B	PPSAD(L)	R	PPSAD7	PPSAD6	PPSAD5	PPSAD4	PPSAD3	PPSAD2	PPSAD1	PPSAD0
		W								
0x027C	PIEAD(H)	R	PIEAD15	PIEAD14	PIEAD13	PIEAD12	PIEAD11	PIEAD10	PIEAD9	PIEAD8
		W								
0x027D	PIEAD(L)	R	PIEAD7	PIEAD6	PIEAD5	PIEAD4	PIEAD3	PIEAD2	PIEAD1	PIEAD0
		W								
0x027E	PIFAD(H)	R	PIFAD15	PIFAD14	PIFAD13	PIFAD12	PIFAD11	PIFAD10	PIFAD9	PIFAD8
		W								
0x027F	PIFAD(L)	R	PIFAD7	PIFAD6	PIFAD5	PIFAD4	PIFAD3	PIFAD2	PIFAD1	PIFAD0
		W								

0x0280 – 0x03FF Reserved Space

Address	Name		Bit 7	Bit 6	Bit 5	Bit 4	Bit 3	Bit 2	Bit 1	Bit 0
0x0280– 0x2FF	Reserved	R	0	0	0	0	0	0	0	0
		W								
0x0300– 0x03FF	Unimplemented	R	0	0	0	0	0	0	0	0
		W								

1.2.2 Part ID Assignments

The part ID is located in two 8-bit registers PARTIDH and PARTIDL (addresses 0x001A and 0x001B after reset). The read-only value is a unique part ID for each revision of the chip. [Table 1-2](#) shows the assigned part ID numbers.

Table 1-2. Assigned Part ID Numbers

Device	Mask Set Number	Part ID ¹
MC9S12E256	0L43X	0x5000

- ¹ The coding is as follows:
- Bit 15–12: Major family identifier
 - Bit 11–8: Minor family identifier
 - Bit 7–4: Major mask set revision number including FAB transfers
 - Bit 3–0: Minor — non full — mask set revision

The device memory sizes are located in two 8-bit registers MEMSIZ0 and MEMSIZ1 (addresses 0x001C and 0x001D after reset). [Table 1-3](#) shows the read-only values of these registers. Refer to [Chapter 19](#), “[Module Mapping Control \(MMCV4\) Block Description](#)” for further details.

Table 1-3. Memory Size Registers

Device	Register name	Value
MC9S12E256	MEMSIZ0	0x07
MC9S12E256	MEMSIZ1	0x81

1.3 Signal Description

1.3.1 Device Pinout

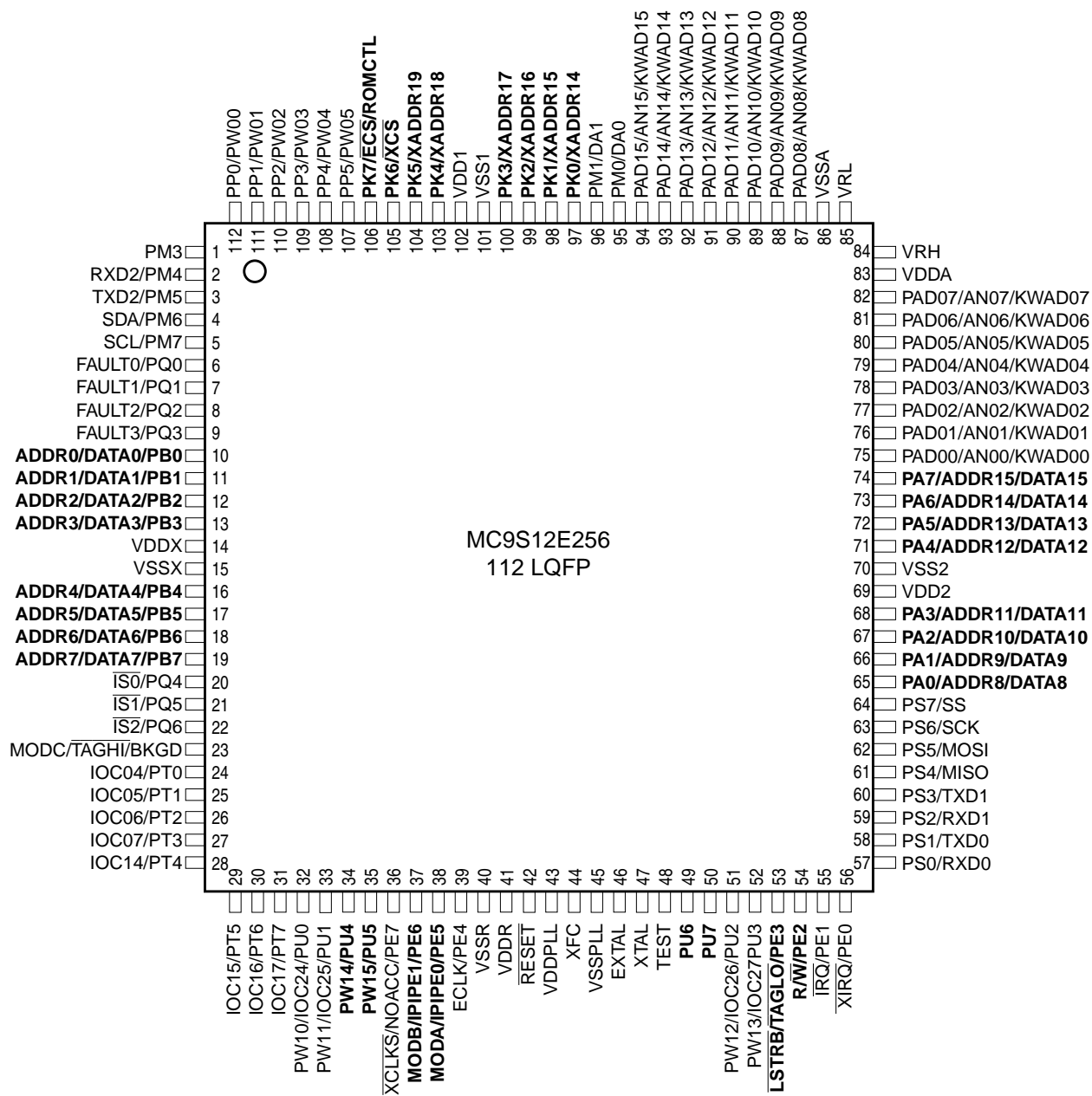

Signals shown in **Bold** are not available on the 80-pin package

Figure 1-3. Pin Assignments for 112-LQFP

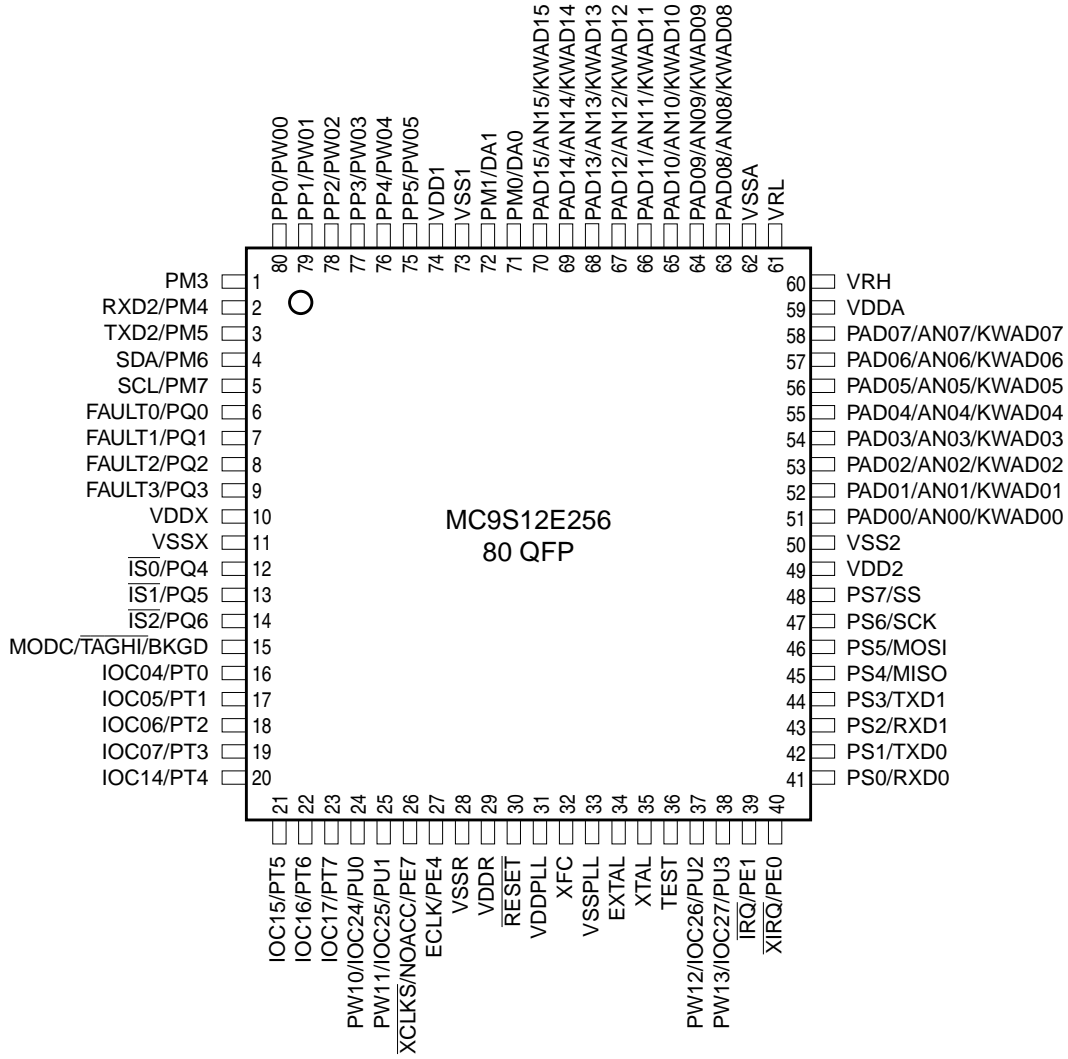

Figure 1-4. Pin Assignments for 80-QFP

1.3.2 Signal Properties Summary

Table 1-4. Signal Properties

Pin Name Function 1	Pin Name Function 2	Pin Name Function 3	Power Domain	Internal Pull Resistor		Description
				CTRL	Reset State	
EXTAL	—	—	VDDPLL	NA	NA	Oscillator pins
XTAL	—	—	VDDPLL	NA	NA	
XFC	—	—	VDDPLL	NA	NA	
RESET	—	—	VDDX	None	None	External reset pin
BKGD	MODC	TAGHI	VDDX	Up	Up	Background debug, mode pin, tag signal high
TEST	VPP	—	NA	NA	NA	Test pin only
PAD[15,13,12,8,6,4,2,0]	AN[15,13,12,8,6,4,2,0]	KWAD[15,13,12,8,6,4,2,0]	VDDX	PERAD/ PPSAD	Disabled	Port AD I/O Pins, ATD inputs, keypad Wake-up
PAD[14,11,10,9,7,5,3,1]	AN[14,11,10,9,7,5,3,1]	KWAD[14,11,10,9,7,5,3,1]	VDDX	PERAD/ PPSAD	Disabled	Port AD I/O Pins, ATD inputs, keypad Wake-up
PA[7:0]	ADDR[15:8]/ DATA[15:8]	—	VDDX	PUCR	Disabled	Port A I/O pin, multiplexed address/data
PB[7:0]	ADDR[7:0]/ DATA[7:0]	—	VDDX	PUCR	Disabled	Port B I/O pin, multiplexed address/data
PE7	NOACC	XCLKS	VDDX	Input	Input	Port E I/O pin, access, clock select
PE6	IPIPE1	MODB	VDDX	While $\overline{\text{RESET}}$ is low: Down		Port E I/O pin, pipe status, mode selection
PE5	IPIPE0	MODA	VDDX	While $\overline{\text{RESET}}$ is low: Down		Port E I/O pin, pipe status, mode selection
PE4	ECLK	—	VDDX	PUCR	Mode Dep ¹	Port E I/O pin, bus clock output
PE3	LSTRB	TAGLO	VDDX	PUCR	Mode Dep ¹	Port E I/O pin, low strobe, tag signal low
PE2	R/W	—	VDDX	PUCR	Mode Dep ¹	Port E I/O pin, R/W in expanded modes
PE1	IRQ	—	VDDX	PUCR	Up	Port E input, external interrupt pin
PE0	XIRQ	—	VDDX	PUCR	Up	Port E input, non-maskable interrupt pin
PK[7]	ECS	ROMCTL	VDDX	PUCR	Up	Port K I/O Pin, Emulation Chip Select
PK[6]	XCS	—	VDDX	PUCR	Up	Port K I/O Pin, External Chip Select
PK[5:0]	XADDR[19:14]	—	VDDX	PUCR	Up	Port K I/O Pins, Extended Addresses
PM7	SCL	—	VDDX	PERM/ PPSM	Up	Port M I/O Pin, IIC SCL signal
PM6	SDA	—	VDDX	PERM/ PPSM	Up	Port M I/O Pin, IIC SDA signal
PM5	TXD2	—	VDDX	PERM/ PPSM	Up	Port M I/O Pin, SCI2 transmit signal
PM4	RXD2	—	VDDX	PERM/ PPSM	Up	Port M I/O Pin, SCI2 receive signal
PM3	—	—	VDDX	PERM/ PPSM	Disabled	Port M I/O Pin
PM1	DAO1	—	VDDX	PERM/ PPSM	Disabled	Port M I/O Pin, DAC1 output

Table 1-4. Signal Properties

Pin Name Function 1	Pin Name Function 2	Pin Name Function 3	Power Domain	Internal Pull Resistor		Description
				CTRL	Reset State	
PM0	DAO0	—	VDDX	PERM/ PPSM	Disabled	Port M I/O Pin, DAC0 output
PP[5:0]	PW0[5:0]	—	VDDX	PERP/ PPSP	Disabled	Port P I/O Pins, PWM output
<i>PQ[6:4]</i>	<i>IS[6:4]</i>	—	VDDX	PERQ/ PPSQ	Disabled	Port Q I/O Pins, \overline{IS} [6:4] input
PQ[3:0]	FAULT[3:0]	—	VDDX	PERQ/ PPSQ	Disabled	Port Q I/O Pins, Fault[3:0] input
PS7	SS	—	VDDX	PERS/ PPSS	Up	Port S I/O Pin, SPI SS signal
PS6	SCK	—	VDDX	PERS/ PPSS	Up	Port S I/O Pin, SPI SCK signal
PS5	MOSI	—	VDDX	PERS/ PPSS	Up	Port S I/O Pin, SPI MOSI signal
PS4	MISO	—	VDDX	PERS/ PPSS	Up	Port S I/O Pin, SPI MISO signal
PS3	TXD1	—	VDDX	PERS/ PPSS	Up	Port S I/O Pin, SCI1 transmit signal
PS2	RXD1	—	VDDX	PERS/ PPSS	Up	Port S I/O Pin, SCI1 receive signal
PS1	TXD0	—	VDDX	PERS/ PPSS	Up	Port S I/O Pin, SCI0 transmit signal
PS0	RXD0	—	VDDX	PERS/ PPSS	Up	Port S I/O Pin, SCI0 receive signal
PT[7:4]	IOC1[7:4]	—	VDDX	PERT/ PPST	Disabled	Port T I/O Pins, timer (TIM1)
PT[3:0]	IOC0[7:4]	—	VDDX	PERT/ PPST	Disabled	Port T I/O Pins, timer (TIM0)
PU[7:6]	—	—	VDDX	PERU/ PPSU	Disabled	Port U I/O Pins
PU[5:4]	PW1[5:4]	—	VDDX	PERU/ PPSU	Disabled	Port U I/O Pins, PWM outputs
<i>PU[3:0]</i>	<i>IOC2[7:4]</i>	<i>PW1[3:0]</i>	VDDX	PERU/ PPSU	Disabled	Port U I/O Pins, timer (TIM2), PWM outputs

¹ The Port E output buffer enable signal control at reset is determined by the PEAR register and is mode dependent. For example, in special test mode RDWE = LSTRE = 1 which enables the PE[3:2] output buffers and disables the pull-ups. Refer to Chapter 18, “Multiplexed External Bus Interface (MEBIV3)” for PEAR register details.

NOTE

Signals shown in **bold** are not available in the 112-pin package.

Signals shown in *italic* are not available in the 80-pin package.

If the port pins are not bonded out in the chosen package the user should initialize the registers to be inputs with enabled pull resistance to avoid excess current consumption. This applies to the following pins:

(80QFP): Port A[7:0], Port B[7:0], Port E[6,5,3,2], Port K[7:0], Port U[7:4]

(64QFN): Port U[3:0], Port Q[6:4], Port M[3], Port AD[14,11,10,9,7,5,3,1]

1.4 Detailed Signal Descriptions

1.4.1 EXTAL, XTAL — Oscillator Pins

EXTAL and XTAL are the external clock and crystal driver pins. On reset all the device clocks are derived from the EXTAL input frequency. XTAL is the crystal output.

1.4.2 $\overline{\text{RESET}}$ — External Reset Pin

RESET is an active low bidirectional control signal that acts as an input to initialize the MCU to a known start-up state. It also acts as an open-drain output to indicate that an internal failure has been detected in either the clock monitor or COP watchdog circuit. External circuitry connected to the RESET pin should not include a large capacitance that would interfere with the ability of this signal to rise to a valid logic one within 32 ECLK cycles after the low drive is released. Upon detection of any reset, an internal circuit drives the RESET pin low and a clocked reset sequence controls when the MCU can begin normal processing.

1.4.3 TEST — Test Pin

The TEST pin is reserved for test and must be tied to VSS in all applications.

1.4.4 XFC — PLL Loop Filter Pin

Dedicated pin used to create the PLL loop filter. See [Chapter 4, “Clocks and Reset Generator \(CRGV4\) Block Description”](#) for more detailed information.

1.4.5 BKGD / $\overline{\text{TAGHI}}$ / MODC — Background Debug, Tag High & Mode Pin

The BKGD / $\overline{\text{TAGHI}}$ / MODC pin is used as a pseudo-open-drain pin for the background debug communication. It is used as a MCU operating mode select pin during reset. The state of this pin is latched to the MODC bit at the rising edge of RESET. In MCU expanded modes of operation, when instruction tagging is on, an input low on this pin during the falling edge of E-clock tags the high half of the instruction word being read into the instruction queue. This pin always has an internal pull up.

1.4.6 PA[7:0] / ADDR[15:8] / DATA[15:8] — Port A I/O Pins

PA[7:0] are general purpose input or output pins. In MCU expanded modes of operation, these pins are used for the multiplexed external address and data bus. PA[7:0] pins are not available in the 80 pin package version.

1.4.7 PB[7:0] / ADDR[7:0] / DATA[7:0] — Port B I/O Pins

PB[7:0] are general purpose input or output pins. In MCU expanded modes of operation, these pins are used for the multiplexed external address and data bus. PB[7:0] pins are not available in the 80 pin package version.

1.4.8 PE7 / NOACC / \overline{XCLKS} — Port E I/O Pin 7

PE7 is a general purpose input or output pin. During MCU expanded modes of operation, the NOACC signal, when enabled, is used to indicate that the current bus cycle is an unused or “free cycle”. This signal will assert when the CPU is not using the bus. The \overline{XCLKS} is an input signal which controls whether a crystal in combination with the internal Colpitts (low power) oscillator is used or whether Pierce oscillator/external clock circuitry is used. The state of this pin is latched at the rising edge of \overline{RESET} . If the input is a logic low the EXTAL pin is configured for an external clock drive or a Pierce Oscillator. If the input is a logic high a Colpitts oscillator circuit is configured on EXTAL and XTAL. Since this pin is an input with a pull-up device during reset, if the pin is left floating, the default configuration is a Colpitts oscillator circuit on EXTAL and XTAL.

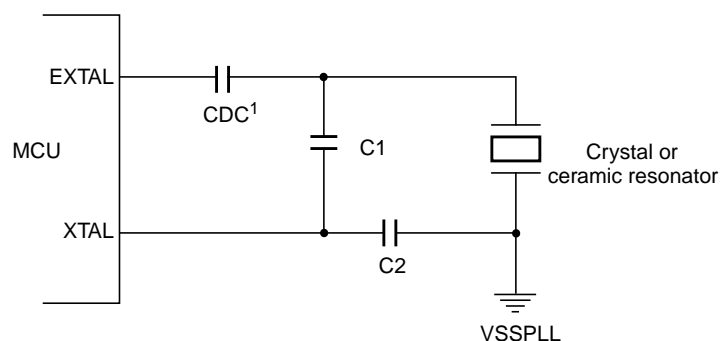

1. Due to the nature of a translated ground Colpitts oscillator a DC voltage bias is applied to the crystal. Please contact the crystal manufacturer for crystal DC

Figure 1-5. Colpitts Oscillator Connections (PE7 = 1)

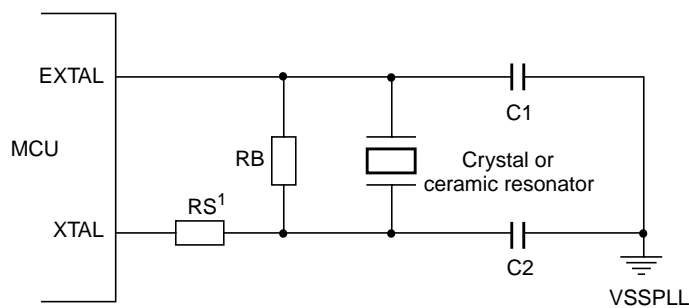

1. Rs can be zero (shorted) when use with higher frequency crystals. Refer to manufacturer's data.

Figure 1-6. Pierce Oscillator Connections (PE7 = 0)

1.4.9 PE6 / MODB / IPIPE1 — Port E I/O Pin 6

PE6 is a general purpose input or output pin. It is used as a MCU operating mode select pin during reset. The state of this pin is latched to the MODB bit at the rising edge of \overline{RESET} . This pin is shared with the instruction queue tracking signal IPIPE1. This pin is an input with a pull-down device which is only active when \overline{RESET} is low. PE6 is not available in the 80 pin package version.

1.4.10 PE5 / MODA / IPIPE0 — Port E I/O Pin 5

PE5 is a general purpose input or output pin. It is used as a MCU operating mode select pin during reset. The state of this pin is latched to the MODA bit at the rising edge of RESET. This pin is shared with the instruction queue tracking signal IPIPE0. This pin is an input with a pull-down device which is only active when RESET is low. PE5 is not available in the 80-pin package version.

1.4.11 PE4 / ECLK— Port E I/O Pin 4 / E-Clock Output

PE4 is a general purpose input or output pin. In Normal Single Chip mode PE4 is configured with an active pull-up while in reset and immediately out of reset. The pullup can be turned off by clearing PUPPEE in the PUCR register. In all modes except Normal Single Chip Mode, the PE4 pin is initially configured as the output connection for the internal bus clock (ECLK). ECLK is used as a timing reference and to demultiplex the address and data in expanded modes. The ECLK frequency is equal to 1/2 the crystal frequency out of reset. The ECLK output function depends upon the settings of the NECLK bit in the PEAR register, the IVIS bit in the MODE register and the ESTR bit in the EBICTL register. All clocks, including the ECLK, are halted when the MCU is in STOP mode. It is possible to configure the MCU to interface to slow external memory. ECLK can be stretched for such accesses. The PE4 pin is initially configured as ECLK output with stretch in all expanded modes. Reference the MISC register (EXSTR[1:0] bits) for more information. In normal expanded narrow mode, the ECLK is available for use in external select decode logic or as a constant speed clock for use in the external application system.

1.4.12 PE3 / $\overline{\text{LSTRB}}$ / $\overline{\text{TAGLO}}$ — Port E I/O Pin 3 / Low-Byte Strobe ($\overline{\text{LSTRB}}$)

PE3 can be used as a general-purpose I/O in all modes and is an input with an active pull-up out of reset. The pullup can be turned off by clearing PUPPEE in the PUCR register. PE3 can also be configured as a Low-Byte Strobe ($\overline{\text{LSTRB}}$). The $\overline{\text{LSTRB}}$ signal is used in write operations, so external low byte writes will not be possible until this function is enabled. $\overline{\text{LSTRB}}$ can be enabled by setting the LSTRE bit in the PEAR register. In Expanded Wide and Emulation Narrow modes, and when BDM tagging is enabled, the $\overline{\text{LSTRB}}$ function is multiplexed with the $\overline{\text{TAGLO}}$ function. When enabled a logic zero on the $\overline{\text{TAGLO}}$ pin at the falling edge of ECLK will tag the low byte of an instruction word being read into the instruction queue. PE3 is not available in the 80 pin package version.

1.4.13 PE2 / $\overline{\text{R}/\overline{\text{W}}}$ — Port E I/O Pin 2 / Read/ $\overline{\text{Write}}$

PE2 can be used as a general-purpose I/O in all modes and is configured an input with an active pull-up out of reset. The pullup can be turned off by clearing PUPPEE in the PUCR register. If the read/write function is required it should be enabled by setting the RDWE bit in the PEAR register. External writes will not be possible until the read/write function is enabled. The PE2 pin is not available in the 80 pin package version.

1.4.14 PE1 / $\overline{\text{IRQ}}$ — Port E input Pin 1 / Maskable Interrupt Pin

PE1 is always an input and can always be read. The PE1 pin is also the $\overline{\text{IRQ}}$ input used for requesting an asynchronous interrupt to the MCU. During reset, the I bit in the condition code register (CCR) is set and any $\overline{\text{IRQ}}$ interrupt is masked until software enables it by clearing the I bit. The $\overline{\text{IRQ}}$ is software

programmable to either falling edge-sensitive triggering or level-sensitive triggering based on the setting of the IRQE bit in the IRQCR register. The \overline{IRQ} is always enabled and configured to level-sensitive triggering out of reset. It can be disabled by clearing IRQEN bit in the IRQCR register. There is an active pull-up on this pin while in reset and immediately out of reset. The pullup can be turned off by clearing PUPPE in the PUCR register.

1.4.15 PE0 / \overline{XIRQ} — Port E input Pin 0 / Non Maskable Interrupt Pin

PE0 is always an input and can always be read. The PE0 pin is also the \overline{XIRQ} input for requesting a nonmaskable asynchronous interrupt to the MCU. During reset, the X bit in the condition code register (CCR) is set and any \overline{XIRQ} interrupt is masked until MCU software enables it by clearing the X bit. Because the \overline{XIRQ} input is level sensitive triggered, it can be connected to a multiple-source wired-OR network. There is an active pull-up on this pin while in reset and immediately out of reset. The pullup can be turned off by clearing PUPPE in the PUCR register.

1.4.16 PK7 / \overline{ECS} / ROMCTL — Port K I/O Pin 7

PK7 is a general purpose input or output pin. During MCU expanded modes of operation, when the EMK bit in the MODE register is set to 1, this pin is used as the emulation chip select output (\overline{ECS}). In expanded modes the PK7 pin can be used to determine the reset state of the ROMON bit in the MISC register. At the rising edge of \overline{RESET} , the state of the PK7 pin is latched to the ROMON bit. There is an active pull-up on this pin while in reset and immediately out of reset. The pullup can be turned off by clearing PUPKE in the PUCR register. Refer to [Chapter 18, “Multiplexed External Bus Interface \(MEBIV3\)”](#) for further details. PK7 is not available in the 80 pin package version.

1.4.17 PK6 / \overline{XCS} — Port K I/O Pin 6

PK6 is a general purpose input or output pin. During MCU expanded modes of operation, when the EMK bit in the MODE register is set to 1, this pin is used as an external chip select signal for most external accesses that are not selected by ECS. There is an active pull-up on this pin while in reset and immediately out of reset. The pullup can be turned off by clearing PUPKE in the PUCR register. Refer to [Chapter 18, “Multiplexed External Bus Interface \(MEBIV3\)”](#) for further details. PK6 is not available in the 80 pin package version.

1.4.18 PK[5:0] / XADDR[19:14] — Port K I/O Pins [5:0]

PK[5:0] are general purpose input or output pins. In MCU expanded modes of operation, when the EMK bit in the MODE register is set to 1, PK[5:0] provide the expanded address XADDR[19:14] for the external bus. There are active pull-ups on PK[5:0] pins while in reset and immediately out of reset. The pullup can be turned off by clearing PUPKE in the PUCR register. Refer to [Chapter 18, “Multiplexed External Bus Interface \(MEBIV3\)”](#) for further details. PK[5:0] are not available in the 80 pin package version.

1.4.19 PAD[15:0] / AN[15:0] / KWAD[15:0] — Port AD I/O Pins [15:0]

PAD[15:0] are the analog inputs for the analog to digital converter (ADC). They can also be configured as general purpose digital input or output pin. When enabled as digital inputs or outputs, the PAD[15:0] can also be configured as Keypad Wake-up pins (KWU) and generate interrupts causing the MCU to exit STOP or WAIT mode. Consult [Chapter 3, “Port Integration Module \(PIM9E256V1\) Block Description”](#) and the [Chapter 6, “Analog-to-Digital Converter \(ATD10B16CV4\) Block Description”](#) for information about pin configurations.

1.4.20 PM7 / SCL — Port M I/O Pin 7

PM7 is a general purpose input or output pin. When the IIC module is enabled it becomes the serial clock line (SCL) for the IIC module (IIC). While in reset and immediately out of reset the PM7 pin is configured as a high impedance input pin. Consult [Chapter 3, “Port Integration Module \(PIM9E256V1\) Block Description”](#) and [Chapter 10, “Inter-Integrated Circuit \(IICV2\) Block Description”](#) for information about pin configurations.

1.4.21 PM6 / SDA — Port M I/O Pin 6

PM6 is a general purpose input or output pin. When the IIC module is enabled it becomes the Serial Data Line (SDL) for the IIC module (IIC). While in reset and immediately out of reset the PM6 pin is configured as a high impedance input pin. Consult [Chapter 3, “Port Integration Module \(PIM9E256V1\) Block Description”](#) and [Chapter 10, “Inter-Integrated Circuit \(IICV2\) Block Description”](#) for information about pin configurations.

1.4.22 PM5 / TXD2 — Port M I/O Pin 5

PM5 is a general purpose input or output. When the Serial Communications Interface 2 (SCI2) transmitter is enabled the PM5 pin is configured as the transmit pin TXD2 of SCI2. While in reset and immediately out of reset the PM5 pin is configured as a high impedance input pin. Consult [Chapter 3, “Port Integration Module \(PIM9E256V1\) Block Description”](#) and [Chapter 8, “Serial Communication Interface \(SCIV4\) Block Description”](#) for information about pin configurations.

1.4.23 PM4 / RXD2 — Port M I/O Pin 4

PM4 is a general purpose input or output. When the Serial Communications Interface 2 (SCI2) receiver is enabled the PM4 pin is configured as the receive pin RXD2 of SCI2. While in reset and immediately out of reset the PM4 pin is configured as a high impedance input pin. Consult [Chapter 3, “Port Integration Module \(PIM9E256V1\) Block Description”](#) and [Chapter 8, “Serial Communication Interface \(SCIV4\) Block Description”](#) for information about pin configurations.

1.4.24 PM3 — Port M I/O Pin 3

PM3 is a general purpose input or output pin. While in reset and immediately out of reset the PM3 pin is configured as a high impedance input pin. Consult [Chapter 3, “Port Integration Module \(PIM9E256V1\) Block Description”](#) for information about pin configurations.

1.4.25 PM1 / DAO1 — Port M I/O Pin 1

PM1 is a general purpose input or output pin. When the Digital to Analog module 1 (DAC1) is enabled the PM1 pin is configured as the analog output DA01 of DAC1. While in reset and immediately out of reset the PM1 pin is configured as a high impedance input pin. Consult [Chapter 3, “Port Integration Module \(PIM9E256V1\) Block Description”](#) and [Chapter 7, “Digital-to-Analog Converter \(DAC8B1CV1\) Block Description”](#) for information about pin configurations.

1.4.26 PM0 / DAO2 — Port M I/O Pin 0

PM0 is a general purpose input or output pin. When the Digital to Analog module 2 (DAC2) is enabled the PM0 pin is configured as the analog output DA02 of DAC2. While in reset and immediately out of reset the PM0 pin is configured as a high impedance input pin. Consult [Chapter 3, “Port Integration Module \(PIM9E256V1\) Block Description”](#) and [Chapter 7, “Digital-to-Analog Converter \(DAC8B1CV1\) Block Description”](#) for information about pin configurations.

1.4.27 PP[5:0] / PW0[5:0] — Port P I/O Pins [5:0]

PP[5:0] are general purpose input or output pins. When the Pulse width Modulator with Fault protection (PMF) is enabled the PP[5:0] output pins, as a whole or as pairs, can be configured as PW0[5:0] outputs. While in reset and immediately out of reset the PP[5:0] pins are configured as a high impedance input pins. Consult [Chapter 3, “Port Integration Module \(PIM9E256V1\) Block Description”](#) and [Chapter 11, “Pulse Width Modulator with Fault Protection \(PMF15B6C\) Module”](#) for information about pin configurations.

1.4.28 PQ[6:4] / IS[2:0] — Port Q I/O Pins [6:4]

PQ[6:4] are general purpose input or output pins. When enabled in the Pulse width Modulator with Fault protection module (PMF), the PQ[6:4] pins become the current status input pins, $\overline{IS}[2:0]$, for top/bottom pulse width correction. While in reset and immediately out of reset PP[5:0] pins are configured as a high impedance input pins. Consult [Chapter 3, “Port Integration Module \(PIM9E256V1\) Block Description”](#) and [Chapter 11, “Pulse Width Modulator with Fault Protection \(PMF15B6C\) Module”](#) for information about pin configurations.

1.4.29 PQ[3:0] / FAULT[3:0] — Port Q I/O Pins [3:0]

PQ[3:0] are general purpose input or output pins. When enabled in the Pulse width Modulator with Fault protection module (PMF), the PQ[3:0] pins become the Fault protection inputs pins, FAULT[3:0], of the PMF. While in reset and immediately out of reset the PQ[3:0] pins are configured as a high impedance input pins. Consult [Chapter 3, “Port Integration Module \(PIM9E256V1\) Block Description”](#) and the [Chapter 11, “Pulse Width Modulator with Fault Protection \(PMF15B6C\) Module”](#) for information about pin configurations.

1.4.30 PS7 / \overline{SS} — Port S I/O Pin 7

PS7 is a general purpose input or output. When the Serial Peripheral Interface (SPI) is enabled PS7 becomes the slave select pin \overline{SS} . While in reset and immediately out of reset the PS7 pin is configured as

a high impedance input pin. Consult [Chapter 3, “Port Integration Module \(PIM9E256V1\) Block Description”](#) and [Chapter 9, “Serial Peripheral Interface \(SPIV3\) Block Description”](#) for information about pin configurations.

1.4.31 PS6 / SCK — Port S I/O Pin 6

PS6 is a general purpose input or output pin. When the Serial Peripheral Interface (SPI) is enabled PS6 becomes the serial clock pin, SCK. While in reset and immediately out of reset the PS6 pin is configured as a high impedance input pin. Consult [Chapter 3, “Port Integration Module \(PIM9E256V1\) Block Description”](#) and [Chapter 9, “Serial Peripheral Interface \(SPIV3\) Block Description”](#) for information about pin configurations.

1.4.32 PS5 / MOSI — Port S I/O Pin 5

PS5 is a general purpose input or output pin. When the Serial Peripheral Interface (SPI) is enabled PS5 is the master output (during master mode) or slave input (during slave mode) pin. While in reset and immediately out of reset the PS5 pin is configured as a high impedance input pin. Consult [Chapter 3, “Port Integration Module \(PIM9E256V1\) Block Description”](#) and [Chapter 9, “Serial Peripheral Interface \(SPIV3\) Block Description”](#) for information about pin configurations.

1.4.33 PS4 / MISO — Port S I/O Pin 4

PS4 is a general purpose input or output pin. When the Serial Peripheral Interface (SPI) is enabled PS4 is the master input (during master mode) or slave output (during slave mode) pin. While in reset and immediately out of reset the PS4 pin is configured as a high impedance input pin. Consult [Chapter 3, “Port Integration Module \(PIM9E256V1\) Block Description”](#) and [Chapter 9, “Serial Peripheral Interface \(SPIV3\) Block Description”](#) for information about pin configurations.

1.4.34 PS3 / TXD1 — Port S I/O Pin 3

PS3 is a general purpose input or output. When the Serial Communications Interface 1 (SCI1) transmitter is enabled the PS3 pin is configured as the transmit pin, TXD1, of SCI1. While in reset and immediately out of reset the PS3 pin is configured as a high impedance input pin. Consult [Chapter 3, “Port Integration Module \(PIM9E256V1\) Block Description”](#) and [Chapter 8, “Serial Communication Interface \(SCIV4\) Block Description”](#) for information about pin configurations.

1.4.35 PS2 / RXD1 — Port S I/O Pin 2

PS2 is a general purpose input or output. When the Serial Communications Interface 1 (SCI1) receiver is enabled the PS2 pin is configured as the receive pin RXD1 of SCI1. While in reset and immediately out of reset the PS2 pin is configured as a high impedance input pin. Consult [Chapter 3, “Port Integration Module \(PIM9E256V1\) Block Description”](#) and [Chapter 8, “Serial Communication Interface \(SCIV4\) Block Description”](#) for information about pin configurations.

1.4.36 PS1 / TXD0 — Port S I/O Pin 1

PS1 is a general purpose input or output. When the Serial Communications Interface 0 (SCI0) transmitter is enabled the PS1 pin is configured as the transmit pin, TXD0, of SCI0. While in reset and immediately out of reset the PS1 pin is configured as a high impedance input pin. Consult [Chapter 3, “Port Integration Module \(PIM9E256V1\) Block Description”](#) and [Chapter 8, “Serial Communication Interface \(SCIV4\) Block Description”](#) for information about pin configurations.

1.4.37 PS0 / RXD0 — Port S I/O Pin 0

PS0 is a general purpose input or output. When the Serial Communications Interface 0 (SCI0) receiver is enabled the PS0 pin is configured as the receive pin RXD0 of SCI0. While in reset and immediately out of reset the PS0 pin is configured as a high impedance input pin. Consult [Chapter 3, “Port Integration Module \(PIM9E256V1\) Block Description”](#) and [Chapter 8, “Serial Communication Interface \(SCIV4\) Block Description”](#) for information about pin configurations.

1.4.38 PT[7:4] / IOC1[7:4]— Port T I/O Pins [7:4]

PT[7:4] are general purpose input or output pins. When the Timer system 1 (TIM1) is enabled they can also be configured as the TIM1 input capture or output compare pins IOC1[7-4]. While in reset and immediately out of reset the PT[7:4] pins are configured as a high impedance input pins. Consult [Chapter 3, “Port Integration Module \(PIM9E256V1\) Block Description”](#) and [Chapter 13, “Timer \(S12TIM16B4CV1\) Block Description”](#) for information about pin configurations.

1.4.39 PT[3:0] / IOC0[7:4]— Port T I/O Pins [3:0]

PT[3:0] are general purpose input or output pins. When the Timer system 0 (TIM0) is enabled they can also be configured as the TIM0 input capture or output compare pins IOC0[7-4]. While in reset and immediately out of reset the PT[3:0] pins are configured as a high impedance input pins. Consult [Chapter 3, “Port Integration Module \(PIM9E256V1\) Block Description”](#) and [Chapter 13, “Timer \(S12TIM16B4CV1\) Block Description”](#) for information about pin configurations.

1.4.40 PU[7:6] — Port U I/O Pins [7:6]

PU[7:6] are general purpose input or output pins. While in reset and immediately out of reset the PU[7:6] pins are configured as a high impedance input pins. Consult [Chapter 3, “Port Integration Module \(PIM9E256V1\) Block Description”](#) for information about pin configurations. PU[7:6] are not available in the 80 pin package version.

1.4.41 PU[5:4] / PW1[5:4] — Port U I/O Pins [5:4]

PU[5:4] are general purpose input or output pins. When the Pulse Width Modulator (PWM) is enabled the PU[5:4] output pins, individually or as a pair, can be configured as PW1[5:4] outputs. While in reset and immediately out of reset the PU[5:4] pins are configured as a high impedance input pins. Consult [Chapter 3, “Port Integration Module \(PIM9E256V1\) Block Description”](#) and [Chapter 12, “Pulse-Width](#)

[Modulator \(PWM8B6CV1\) Block Description](#)” for information about pin configurations. PU[5:4] are not available in the 80 pin package version.

1.4.42 PU[3:0] / IOC2[7:4]/PW1[3:0] — Port U I/O Pins [3:0]

PU[3:0] are general purpose input or output pins. When the Timer system 2 (TIM2) is enabled they can also be configured as the TIM2 input capture or output compare pins IOC2[7-4]. When the Pulse Width Modulator (PWM) is enabled the PU[3:0] output pins, individually or as a pair, can be configured as PW1[3:0] outputs. The MODRR register in the Port Integration Module determines if the TIM2 or PWM function is selected. While in reset and immediately out of reset the PU[3:0] pins are configured as a high impedance input pins. Consult [Chapter 3, “Port Integration Module \(PIM9E256V1\) Block Description”](#), [Chapter 13, “Timer \(S12TIM16B4CV1\) Block Description”](#), and [Chapter 12, “Pulse-Width Modulator \(PWM8B6CV1\) Block Description”](#) for information about pin configurations.

1.4.43 VDDX,VSSX — Power & Ground Pins for I/O Drivers

External power and ground for I/O drivers. Bypass requirements depend on how heavily the MCU pins are loaded.

1.4.44 VDDR, VSSR — Power Supply Pins for I/O Drivers & for Internal Voltage Regulator

External power and ground for I/O drivers and input to the internal voltage regulator. Bypass requirements depend on how heavily the MCU pins are loaded.

1.4.45 VDD1, VDD2, VSS1, VSS2 — Power Supply Pins for Internal Logic

Power is supplied to the MCU through VDD and VSS. This 2.5V supply is derived from the internal voltage regulator. There is no static load on those pins allowed. The internal voltage regulator is turned off, if VDDR is tied to ground.

1.4.46 VDDA, VSSA — Power Supply Pins for ATD and VREG

VDDA, VSSA are the power supply and ground input pins for the voltage regulator and the analog to digital converter.

1.4.47 VRH, VRL — ATD Reference Voltage Input Pins

VRH and VRL are the reference voltage input pins for the analog to digital converter.

1.4.48 VDDPLL, VSSPLL — Power Supply Pins for PLL

Provides operating voltage and ground for the Oscillator and the Phased-Locked Loop. This allows the supply voltage to the Oscillator and PLL to be bypassed independently. This 2.5V voltage is generated by the internal voltage regulator.

Table 1-5. MC9S12E256 Power and Ground Connection Summary

Mnemonic	Nominal Voltage	Description
VDD1, VDD2	2.5 V	Internal power and ground generated by internal regulator. These also allow an external source to supply the core VDD/VSS voltages and bypass the internal voltage regulator.
VSS1, VSS2	0V	
VDDR	3.3/5.0 V	External power and ground, supply to internal voltage regulator. To disable voltage regulator attach V_{DDR} to V_{SSR} .
VSSR	0 V	
VDDX	3.3/5.0 V	External power and ground, supply to pin drivers.
VSSX	0 V	
VDDA	3.3/5.0 V	Operating voltage and ground for the analog-to-digital converter, the reference for the internal voltage regulator and the digital-to-analog converters, allows the supply voltage to the A/D to be bypassed independently.
VSSA	0 V	
VRH	3.3/5.0 V	Reference voltage high for the ATD converter, and DAC.
VRL	0 V	Reference voltage low for the ATD converter.
VDDPLL	2.5 V	Provides operating voltage and ground for the Phased-Locked Loop. This allows the supply voltage to the PLL to be bypassed independently. Internal power and ground generated by internal regulator.
VSSPLL	0 V	

NOTE

All VSS pins must be connected together in the application. Because fast signal transitions place high, short-duration current demands on the power supply, use bypass capacitors with high-frequency characteristics and place them as close to the MCU as possible. Bypass requirements depend on MCU pin load.

1.5 System Clock Description

The Clock and Reset Generator provides the internal clock signals for the core and all peripheral modules. [Figure 1-7](#) shows the clock connections from the CRG to all modules. Consult [Chapter 4, “Clocks and Reset Generator \(CRGV4\) Block Description”](#) for details on clock generation.

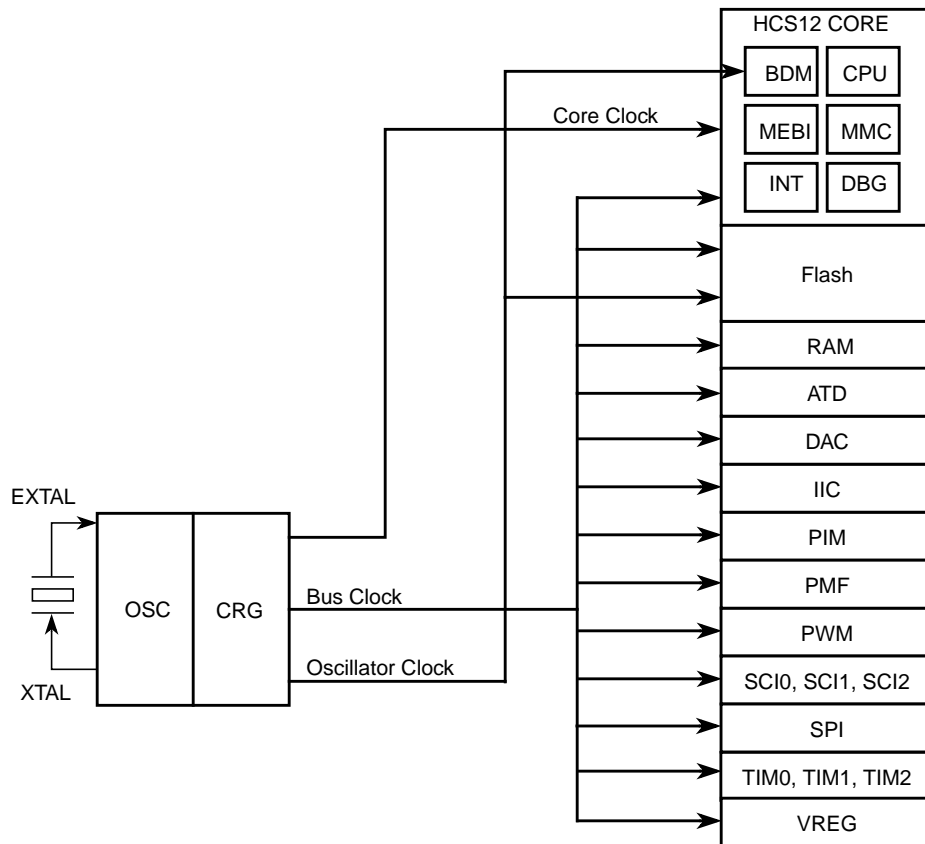

Figure 1-7. Clock Connections

Table 1-6. Clock Selection Based on PE7

PE7 = \overline{XCLKS}	Description
1	Colpitts Oscillator selected
0	Pierce Oscillator/external clock selected

1.6 Modes of Operation

1.6.1 Overview

Eight possible modes determine the operating configuration of the MC9S12E256. Each mode has an associated default memory map and external bus configuration controlled by a further pin.

Three low power modes exist for the device.

1.6.2 Chip Configuration Summary

The operating mode out of reset is determined by the states of the MODC, MODB, and MODA pins during reset. The MODC, MODB, and MODA bits in the MODE register show the current operating mode and provide limited mode switching during operation. The states of the MODC, MODB, and MODA pins are latched into these bits on the rising edge of the reset signal. The ROMCTL signal allows the setting of the ROMON bit in the MISC register thus controlling whether the internal Flash is visible in the memory map. ROMON = 1 mean the Flash is visible in the memory map. The state of the ROMCTL pin is latched into the ROMON bit in the MISC register on the rising edge of the reset signal.

Table 1-7. Mode Selection

BKGD = MODC	PE6 = MODB	PE5 = MODA	PK7 = ROMCTL	ROMON Bit	Mode Description
0	0	0	X	1	Special Single Chip, BDM allowed and ACTIVE. BDM is allowed in all other modes but a serial command is required to make BDM active.
0	0	1	0	1	Emulation Expanded Narrow, BDM allowed
			1	0	
0	1	0	X	0	Special Test (Expanded Wide), BDM allowed
0	1	1	0	1	Emulation Expanded Wide, BDM allowed
			1	0	
1	0	0	X	1	Normal Single Chip, BDM allowed
1	0	1	0	0	Normal Expanded Narrow, BDM allowed
			1	1	
1	1	0	X	1	Peripheral; BDM allowed but bus operations would cause bus conflicts (must not be used)
1	1	1	0	0	Normal Expanded Wide, BDM allowed
			1	1	

For further explanation on the modes refer to [Chapter 18, “Multiplexed External Bus Interface \(MEBIV3\)”](#).

Table 1-8. Clock Selection Based on PE7

PE7 = XCLKS	Description
1	Colpitts Oscillator selected
0	Pierce Oscillator/external clock selected

1.7 Security

The device will make available a security feature preventing the unauthorized read and write of the memory contents. This feature allows:

- Protection of the contents of FLASH,
- Operation in single-chip mode,
- Operation from external memory with internal FLASH disabled.

The user must be reminded that part of the security must lie with the user's code. An extreme example would be user's code that dumps the contents of the internal program. This code would defeat the purpose of security. At the same time the user may also wish to put a back door in the user's program. An example of this is the user downloads a key through the SCI which allows access to a programming routine that updates parameters.

1.7.1 Securing the Microcontroller

Once the user has programmed the FLASH, the part can be secured by programming the security bits located in the FLASH module. These non-volatile bits will keep the part secured through resetting the part and through powering down the part.

The security byte resides in a portion of the Flash array.

Check [Chapter 2, "256 Kbyte Flash Module \(S12FTS256K2V1\)"](#) for more details on the security configuration.

1.7.2 Operation of the Secured Microcontroller

1.7.2.1 Normal Single Chip Mode

This will be the most common usage of the secured part. Everything will appear the same as if the part was not secured with the exception of BDM operation. The BDM operation will be blocked.

1.7.2.2 Executing from External Memory

The user may wish to execute from external space with a secured microcontroller. This is accomplished by resetting directly into expanded mode. The internal FLASH will be disabled. BDM operations will be blocked.

1.7.3 Unsecuring the Microcontroller

In order to unsecure the microcontroller, the internal FLASH must be erased. This can be done through an external program in expanded mode.

Once the user has erased the FLASH, the part can be reset into special single chip mode. This invokes a program that verifies the erasure of the internal FLASH. Once this program completes, the user can erase and program the FLASH security bits to the unsecured state. This is generally done through the BDM, but the user could also change to expanded mode (by writing the mode bits through the BDM) and jumping to

an external program (again through BDM commands). Note that if the part goes through a reset before the security bits are reprogrammed to the unsecure state, the part will be secured again.

1.8 Low Power Modes

The microcontroller features three main low power modes. Consult the respective block description chapter for information on the module behavior in Stop, Pseudo Stop, and Wait Mode. An important source of information about the clock system is [Chapter 4, “Clocks and Reset Generator \(CRGV4\) Block Description”](#).

1.8.1 Stop

Executing the CPU STOP instruction stops all clocks and the oscillator thus putting the chip in fully static mode. Wake up from this mode can be done via reset or external interrupts.

1.8.2 Pseudo Stop

This mode is entered by executing the CPU STOP instruction. In this mode the oscillator is still running and the Real Time Interrupt (RTI) or Watchdog (COP) sub module can stay active. Other peripherals are turned off. This mode consumes more current than the full STOP mode, but the wake up time from this mode is significantly shorter.

1.8.3 Wait

This mode is entered by executing the CPU WAI instruction. In this mode the CPU will not execute instructions. The internal CPU signals (address and data bus) will be fully static. All peripherals stay active. For further power consumption the peripherals can individually turn off their local clocks.

1.8.4 Run

Although this is not a low power mode, unused peripheral modules should not be enabled in order to save power.

1.9 Resets and Interrupts

Consult the Exception Processing section of the CPU12 Reference Manual for information on resets and interrupts. System resets can be generated through external control of the $\overline{\text{RESET}}$ pin, through the clock and reset generator module CRG or through the low voltage reset (LVR) generator of the voltage regulator module. Refer to [Chapter 4, “Clocks and Reset Generator \(CRGV4\) Block Description”](#) and [Chapter 14, “Dual Output Voltage Regulator \(VREG3V3V2\) Block Description”](#) for detailed information on reset generation.

1.9.1 Vectors

[Table 1-9](#) lists interrupt sources and vectors in default order of priority.

Table 1-9. Interrupt Vector Locations

Vector Address	Interrupt Source	CCR Mask	Local Enable	HPRIO Value to Elevate
0xFFFFE, 0xFFFFF	External Reset, Power On Reset or Low Voltage Reset (see Section 4.3.2.4 , “ CRG Flags Register (CRGFLG) ” to determine reset source)	None	None	–
0xFFFC, 0xFFFD	Clock Monitor fail reset	None	COPCTL (CME, FCME)	–
0xFFFA, 0xFFFB	COP failure reset	None	COP rate select	–
0xFFFF8, 0xFFFF9	Unimplemented instruction trap	None	None	–
0xFFFF6, 0xFFFF7	SWI	None	None	–
0xFFFF4, 0xFFFF5	XIRQ	X-Bit	None	–
0xFFFF2, 0xFFFF3	IRQ	I-Bit	INTCR (IRQEN)	0xF2
0xFFFF0, 0xFFFF1	Real Time Interrupt	I-Bit	CRGINT (RTIE)	0xF0
0xFFE8 to 0xFFEF	Reserved			
0xFFE6, 0xFFE7	Standard Timer 0 channel 4	I-Bit	TIE (C4I)	0xE6
0xFFE4, 0xFFE5	Standard Timer 0 channel 5	I-Bit	TIE (C5I)	0xE4
0xFFE2, 0xFFE3	Standard Timer 0 channel 6	I-Bit	TIE (C6I)	0xE2
0xFFE0, 0xFFE1	Standard Timer 0 channel 7	I-Bit	TIE (C7I)	0xE0
0xFFDE, 0xFFDF	Standard Timer overflow	I-Bit	TSCR2 (TOI)	0xDE
0xFFDC, 0xFFDD	Pulse accumulator overflow	I-Bit	PACTL(PAOVI)	0xDC
0xFFDA, 0xFFDB	Pulse accumulator input edge	I-Bit	PACTL (PAI)	0xDA
0xFFD8, 0xFFD9	SPI	I-Bit	SPICR1 (SPIE, SPTIE)	0xD8
0xFFD6, 0xFFD7	SCI0	I-Bit	SCICR2 (TIE, TCIE, RIE, ILIE)	0xD6
0xFFD4, 0xFFD5	SCI1	I-Bit	SCICR2 (TIE, TCIE, RIE, ILIE)	0xD4
0xFFD2, 0xFFD3	SCI2	I-Bit	SCICR2 (TIE, TCIE, RIE, ILIE)	0xD2
0xFFD0, 0xFFD1	ATD	I-Bit	ATDCTL2 (ASCIE)	0xD0
0xFFCE, 0xFFCF	Port AD (KWU)	I-Bit	PTADIF (PTADIE)	0xCE
0xFFC8 to 0xFFCD	Reserved			
0xFFC6, 0xFFC7	CRG PLL lock	I-Bit	PLLCR (LOCKIE)	0xC6
0xFFC4, 0xFFC5	CRG Self Clock Mode	I-Bit	PLLCR (SCMIE)	0xC4
0xFFC2, 0xFFC3	Reserved			
0xFFC0, 0xFFC1	IIC Bus	I-Bit	IBCR (IBIE)	0xC0
0xFFBA to 0xFFBF	Reserved			
0xFFB8, 0xFFB9	FLASH	I-Bit	FCNFG (CCIE, CBEIE)	0xB8
0xFFB6, 0xFFB7	Standard Timer 1 channel 4	I-Bit	TIE (C4I)	0xB6
0xFFB4, 0xFFB5	Standard Timer 1 channel 5	I-Bit	TIE (C5I)	0xB4
0xFFB2, 0xFFB3	Standard Timer 1 channel 6	I-Bit	TIE (C6I)	0xB2
0xFFB0, 0xFFB1	Standard Timer 1 channel 7	I-Bit	TIE (C7I)	0xB0
0xFFAE, 0xFFAF	Standard Timer 1 overflow	I-Bit	TSCR2 (TOI)	0xAE

Table 1-9. Interrupt Vector Locations (continued)

Vector Address	Interrupt Source	CCR Mask	Local Enable	HPRIO Value to Elevate
0xFFAC, 0xFFAD	Standard Timer 1 Pulse accumulator overflow	I-Bit	PACTL (PAOVI)	0xAC
0xFFAA, 0xFFAB	Standard Timer 1 Pulse accumulator input edge	I-Bit	PACTL (PAI)	0xAA
0xFFA8, 0xFFA9	Reserved			
0xFFA6, 0xFFA7	Standard Timer 2 channel 4	I-Bit	TIE (C4I)	0xA6
0xFFA4, 0xFFA5	Standard Timer 2 channel 5	I-Bit	TIE (C5I)	0xA4
0xFFA2, 0xFFA3	Standard Timer 2 channel 6	I-Bit	TIE (C6I)	0xA2
0xFFA0, 0xFFA1	Standard Timer 2 channel 7	I-Bit	TIE (C7I)	0xA0
0xFF9E, 0xFF9F	Standard Timer overflow	I-Bit	TSCR2 (TOI)	0x9E
0xFF9C, 0xFF9D	Standard Timer 2 Pulse accumulator overflow	I-Bit	PACTL (PAOVI)	0x9C
0xFF9A, 0xFF9B	Standard Timer 2 Pulse accumulator input edge	I-Bit	PACTL (PAI)	0x9A
0xFF98, 0xFF99	PMF Generator A Reload	I-Bit	PMFENCA (PWMRIEA)	0x98
0xFF96, 0xFF97	PMF Generator B Reload	I-Bit	PMFENCB (PWMRIEB)	0x96
0xFF94, 0xFF95	PMF Generator C Reload	I-Bit	PMFENCC (PWMRIEC)	0x94
0xFF92, 0xFF93	PMF Fault 0	I-Bit	PMFFCTL (FIE0)	0x92
0xFF90, 0xFF91	PMF Fault 1	I-Bit	PMFFCTL (FIE1)	0x90
0xFF8E, 0xFF8F	PMF Fault 2	I-Bit	PMFFCTL (FIE2)	0x8E
0xFF8C, 0xFF8D	PMF Fault 3	I-Bit	PMFFCTL (FIE3)	0x8C
0xFF8A, 0xFF8B	VREG LVI	I-Bit	CTRL0 (LVIE)	0x8A
0xFF88, 0xFF89	PWM Emergency Shutdown	I-Bit	PWMSDN(PWMIE)	0x88
0xFF80 to 0xFF87	Reserved			

1.9.2 Resets

Resets are a subset of the interrupts featured in [Table 1-9](#). The different sources capable of generating a system reset are summarized in [Table 1-10](#).

1.9.2.1 Reset Summary Table

Table 1-10. Reset Summary

Reset	Priority	Source	Vector
Power-on Reset	1	CRG Module	0xFFFFE, 0xFFFF
External Reset	1	RESET pin	0xFFFFE, 0xFFFF
Low Voltage Reset	1	VREG Module	0xFFFFE, 0xFFFF
Clock Monitor Reset	2	CRG Module	0xFFFFC, 0xFFFFD
COP Watchdog Reset	3	CRG Module	0xFFFFA, 0xFFFFB

1.9.2.2 Effects of Reset

When a reset occurs, MCU registers and control bits are changed to known start-up states. Refer to the respective module block description chapters for register reset states. Refer to [Chapter 18, “Multiplexed External Bus Interface \(MEBIV3\)”](#) for mode dependent pin configuration of port A, B and E out of reset.

Refer to [Chapter 3, “Port Integration Module \(PIM9E256V1\) Block Description”](#) for reset configurations of all peripheral module ports.

Refer to [Table 1-1](#) for locations of the memories depending on the operating mode after reset.

The RAM array is not automatically initialized out of reset.

1.10 Recommended Printed Circuit Board Layout

The Printed Circuit Board (PCB) must be carefully laid out to ensure proper operation of the voltage regulator as well as the MCU itself. The following rules must be observed:

- Every supply pair must be decoupled by a ceramic capacitor connected as near as possible to the corresponding pins (C1–C6).
- Central point of the ground star should be the VSSR pin.
- Use low ohmic low inductance connections between VSS1, VSS2 and VSSR.
- VSSPLL must be directly connected to VSSR.
- Keep traces of VSSPLL, EXTAL and XTAL as short as possible and occupied board area for C7, C8, C11 and Q1 as small as possible.
- Do not place other signals or supplies underneath area occupied by C7, C8, C10 and Q1 and the connection area to the MCU.
- Central power input should be fed in at the VDDA/VSSA pins.

Table 1-11. Recommended Decoupling Capacitor Choice

Component	Purpose	Type	Value
C1	VDD1 filter cap	Ceramic X7R	100–220nF
C2	VDD2 filter cap (80 QFP only)	Ceramic X7R	100–220nF
C3	VDDA filter cap	Ceramic X7R	100nF
C4	VDDR filter cap	X7R/tantalum	≥ 100 nF
C5	VDDPLL filter cap	Ceramic X7R	100nF
C6	VDDX filter cap	X7R/tantalum	≥ 100 nF
C7	OSC load cap	See PLL specification chapter	
C8	OSC load cap		
C9	PLL loop filter cap		
C10	PLL loop filter cap		
C11	DC cutoff cap		
R1	PLL loop filter res		
Q1	Quartz		

NOTE: Oscillator in Colpitts mode.

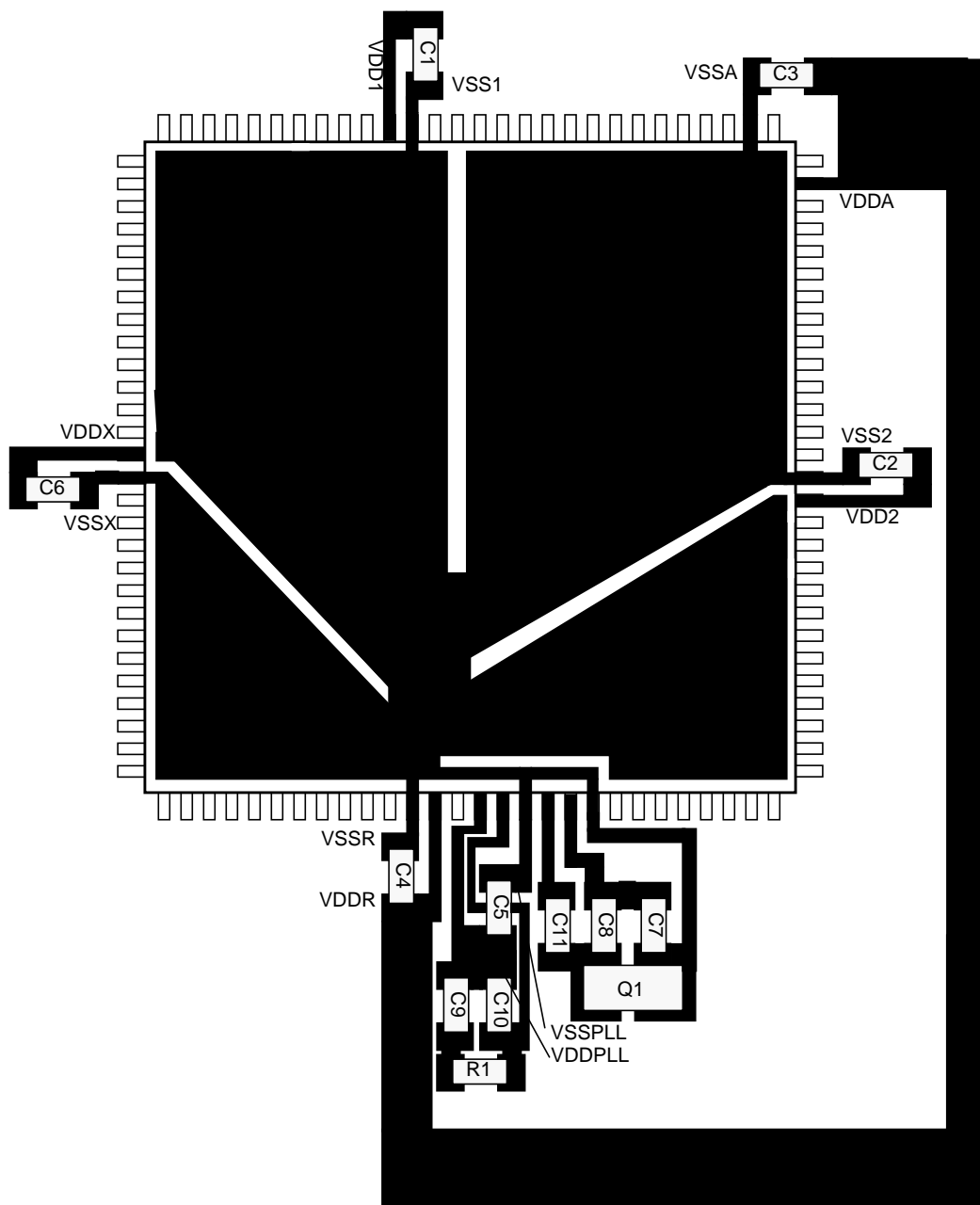

Figure 1-8. Recommended PCB Layout (112-LQFP)

NOTE: Oscillator in Colpitts mode.

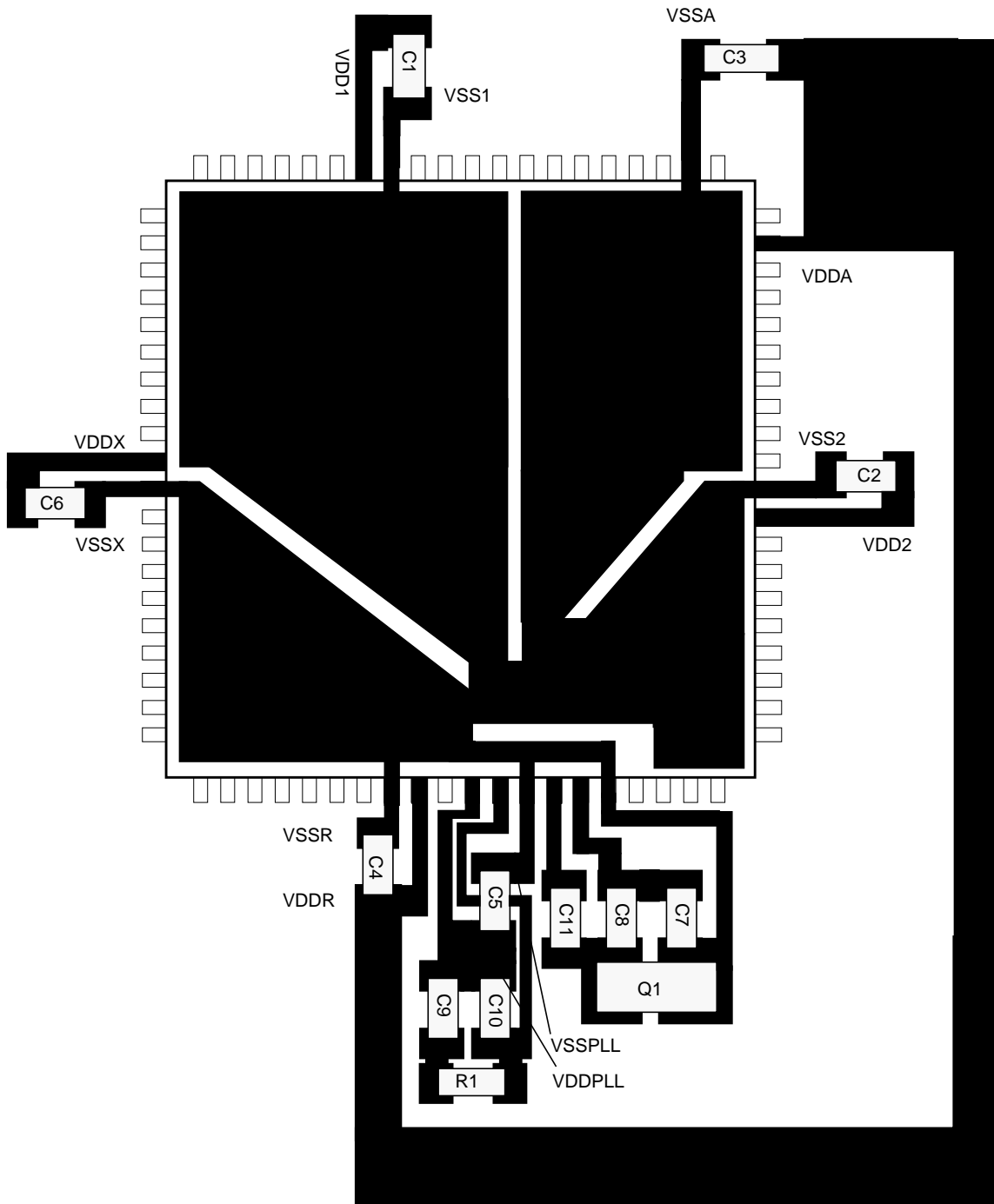

Figure 1-9. Recommended PCB Layout (80-QFP)



Chapter 2

256 Kbyte Flash Module (S12FTS256K2V1)

Table 2-1. FTS256K2 Revision History

Version Number	Revision Date	Author	Description of Changes
V01.01	04APR05		Reformat document.
V01.02	15SEP06		<ol style="list-style-type: none"> 1. Add address range restriction to data compress command. 2. Describe algorithm for data compress command. 3. Add note about margin read during data compress command.
V01.03	05DEC06		<ol style="list-style-type: none"> 1. Clarify in Section 2.3.2.7, Section 2.4.1.2, Section 2.4.1.4 that ACCERR, PVIOL, FAIL flags must be clear in both banked FSTAT registers before starting a command write sequence.

2.1 Introduction

This document describes the FTS256K2 module that includes a 256 Kbyte Flash (nonvolatile) memory. The Flash memory may be read as either bytes, aligned words, or misaligned words. Read access time is one bus cycle for bytes and aligned words, and two bus cycles for misaligned words.

The Flash memory is ideal for program and data storage for single-supply applications allowing for field reprogramming without requiring external voltage sources for program or erase. Program and erase functions are controlled by a command driven interface. The Flash module supports both block erase and sector erase. An erased bit reads 1 and a programmed bit reads 0. The high voltage required to program and erase the Flash memory is generated internally. It is not possible to read from a Flash block while it is being erased or programmed.

CAUTION

A Flash word must be in the erased state before being programmed.
Cumulative programming of bits within a Flash word is not allowed.

2.1.1 Glossary

Banked Register — A memory-mapped register operating on one Flash block which shares the same register address as the equivalent registers for the other Flash blocks. The active register bank is selected by the BKSEL bit in the FCNFG register.

Command Write Sequence — A three-step MCU instruction sequence to execute built-in algorithms (including program and erase) on the Flash memory.

Common Register — A memory-mapped register which operates on all Flash blocks.

2.1.2 Features

- 256 Kbytes of Flash memory comprised of two 128 Kbyte blocks with each block divided into 128 sectors of 1024 bytes
- Automated program and erase algorithm
- Interrupts on Flash command completion, command buffer empty
- Fast sector erase and word program operation
- 2-stage command pipeline for faster multi-word program times
- Sector erase abort feature for critical interrupt response
- Flexible protection scheme to prevent accidental program or erase
- Single power supply for all Flash operations including program and erase
- Security feature to prevent unauthorized access to the Flash memory
- Code integrity check using built-in data compression

2.1.3 Modes of Operation

Program, erase, erase verify, and data compress operations (please refer to [Section 2.4.1](#) for details).

2.1.4 Block Diagram

A block diagram of the Flash module is shown in [Figure 2-1](#).

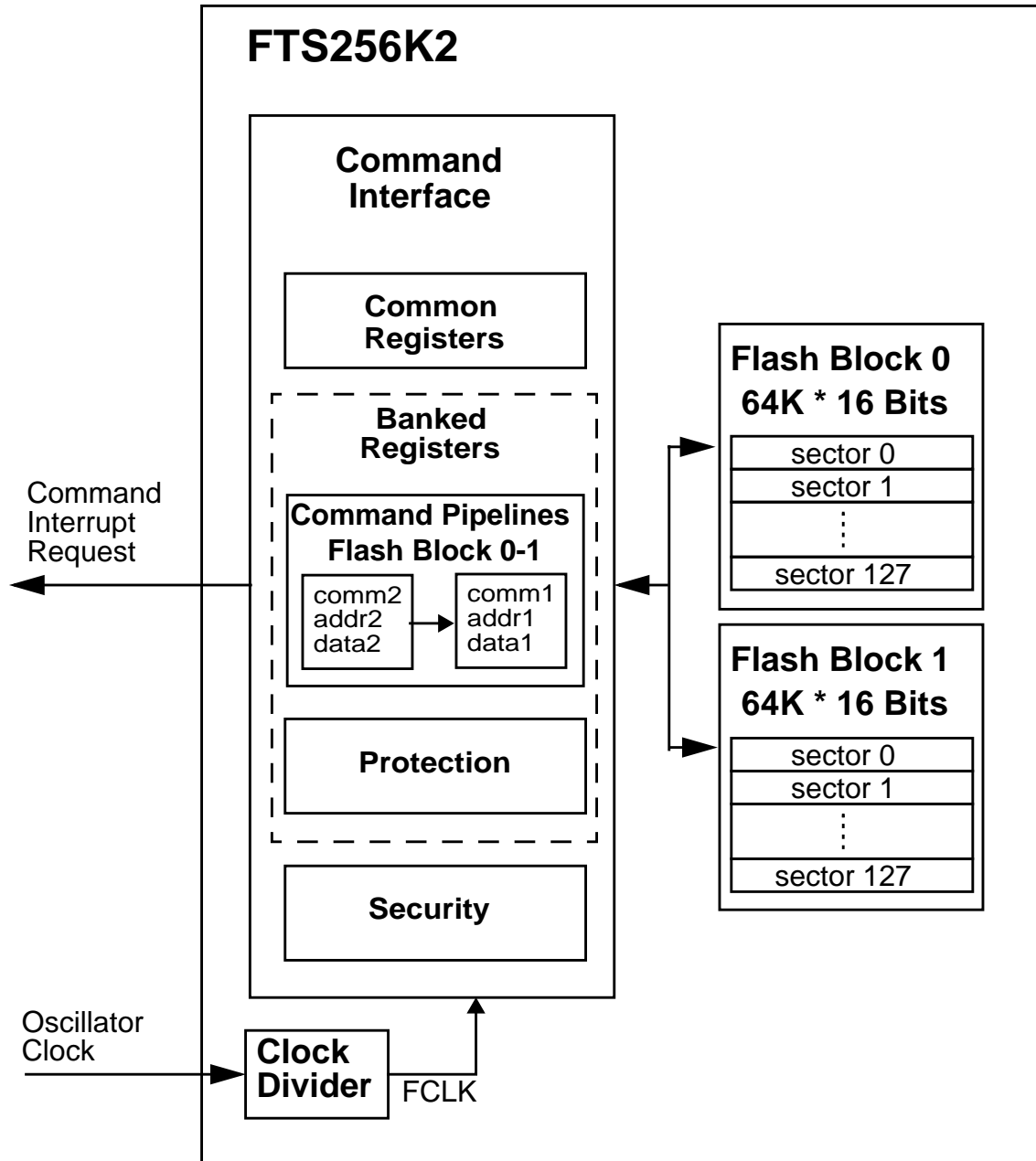

Figure 2-1. FTS256K2 Block Diagram

2.2 External Signal Description

The Flash module contains no signals that connect off-chip.

2.3 Memory Map and Register Definition

This subsection describes the memory map and registers for the Flash module.

2.3.1 Module Memory Map

The Flash memory map is shown in [Figure 2-2](#). The HCS12 architecture places the Flash memory addresses between 0x4000 and 0xFFFF which corresponds to three 16-Kbyte pages. The content of the HCS12 core PPAGE register is used to map the logical middle page ranging from address 0x8000 to 0xBFFF to any physical 16 Kbyte page in the Flash memory. By placing 0x3E or 0x3F in the HCS12 Core PPAGE register, the associated 16 Kbyte pages appear twice in the MCU memory map.

The FPROT register, described in [Section 2.3.2.5, “Flash Protection Register \(FPROT\)”](#), can be set to globally protect a Flash block. However, three separate memory regions, one growing upward from the first address in the next-to-last page in the Flash block (called the lower region), one growing downward from the last address in the last page in the Flash block (called the higher region), and the remaining addresses in the Flash block, can be activated for protection. The Flash locations of these protectable regions are shown in [Table 2-3](#). The higher address region of Flash block 0 is mainly targeted to hold the boot loader code because it covers the vector space. The lower address region of any Flash block can be used for EEPROM emulation in an MCU without an EEPROM module because it can remain unprotected while the remaining addresses are protected from program or erase.

Security information that allows the MCU to restrict access to the Flash module is stored in the Flash configuration field found in Flash block 0, described in [Table 2-2](#).

Table 2-2. Flash Configuration Field

Unpaged Flash Address	Paged Flash Address (PPAGE 0x3F)	Size (Bytes)	Description
0xFF00 – 0xFF07	0xBF00 – 0xBF07	8	Backdoor Comparison Key Refer to Section 2.6.1, “Unsecuring the MCU using Backdoor Key Access”
0xFF08 – 0xFF0B	0xBF08 – 0xBF0B	4	Reserved
0xFF0C	0xBF0C	1	Block 1 Flash Protection Byte Refer to Section 2.3.2.7, “Flash Status Register (FSTAT)”
0xFF0D	0xBF0D	1	Block 0 Flash Protection Byte Refer to Section 2.3.2.7, “Flash Status Register (FSTAT)”
0xFF0E	0xBF0E	1	Flash Nonvolatile Byte Refer to Section 2.3.2.9, “Flash Control Register (FCTL)”
0xFF0F	0xBF0F	1	Flash Security Byte Refer to Section 2.3.2.2, “Flash Security Register (FSEC)”

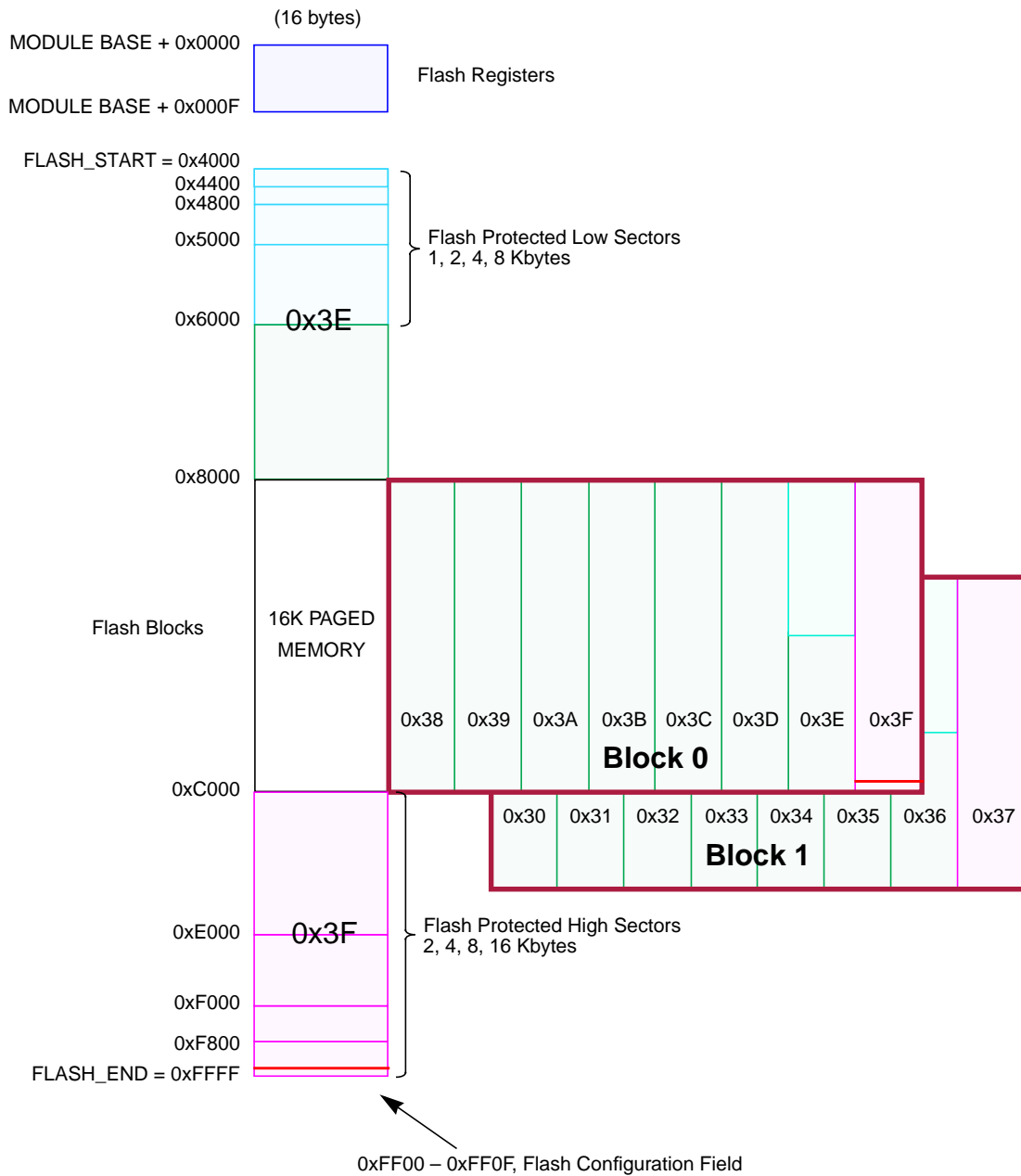

Note: 0x30–0x3F correspond to the PPAGE register content

Figure 2-2. Flash Memory Map

Table 2-3. Detailed Flash Memory Map

MCU Address Range	PPAGE	Protectable Lower Range	Protectable Higher Range	Flash Block	Block Relative Address ¹
0x4000–0x7FFF	Unpaged (0x3E)	0x4000–0x43FF 0x4000–0x47FF 0x4000–0x4FFF 0x4000–0x5FFF	N.A.	0	0x018000–0x01BFFF
0x8000–0xBFFF	0x30	N.A.	N.A.	1	0x000000–0x003FFF
	0x31	N.A.	N.A.		0x004000–0x007FFF
	0x32	N.A.	N.A.		0x008000–0x00BFFF
	0x33	N.A.	N.A.		0x00C000–0x00FFFF
	0x34	N.A.	N.A.		0x010000–0x013FFF
	0x35	N.A.	N.A.		0x014000–0x017FFF
	0x36	0x8000–0x83FF 0x8000–0x87FF 0x8000–0x8FFF 0x8000–0x9FFF	N.A.		0x018000–0x01BFFF
	0x37	N.A.	0xB800–0xBFFF 0xB000–0xBFFF 0xA000–0xBFFF 0x8000–0xBFFF		0x01C000–0x01FFFF
0x8000–0xBFFF	0x38	N.A.	N.A.	0	0x000000–0x003FFF
	0x39	N.A.	N.A.		0x004000–0x007FFF
	0x3A	N.A.	N.A.		0x008000–0x00BFFF
	0x3B	N.A.	N.A.		0x00C000–0x00FFFF
	0x3C	N.A.	N.A.		0x010000–0x013FFF
	0x3D	N.A.	N.A.		0x014000–0x017FFF
	0x3E	0x8000–0x83FF 0x8000–0x87FF 0x8000–0x8FFF 0x8000–0x9FFF	N.A.		0x018000–0x01BFFF
	0x3F	N.A.	0xB800–0xBFFF 0xB000–0xBFFF 0xA000–0xBFFF 0x8000–0xBFFF		0x01C000–0x01FFFF
0xC000–0xFFFF	Unpaged (0x3F)	N.A.	0xF800–0xFFFF 0xF000–0xFFFF 0xE000–0xFFFF 0xC000–0xFFFF	0	0x01C000–0x01FFFF

¹ Block relative address for each 128 Kbyte Flash block consists of 17 address bits.

The Flash module also contains a set of 16 control and status registers located in address space module base + 0x0000 to module base + 0x000F. In order to accommodate more than one Flash block with a minimum register address space, a set of registers located from module base + 0x0004 to module base + 0x000B are repeated in all banks. The active register bank is selected by the BKSEL bits in the unbanked Flash configuration register (FCNFG). A summary of these registers is given in [Table 2-4](#) while their accessibility in normal and special modes is detailed in [Section 2.3.2, “Register Descriptions”](#).

Table 2-4. Flash Register Map

Module Base +	Register Name	Normal Mode Access
0x0000	Flash Clock Divider Register (FCLKDIV)	R/W
0x0001	Flash Security Register (FSEC)	R
0x0002	Flash Test Mode Register (FTSTMOD) ¹	R
0x0003	Flash Configuration Register (FCNFG)	R/W
0x0004	Flash Protection Register (FPROT)	R/W
0x0005	Flash Status Register (FSTAT)	R/W
0x0006	Flash Command Register (FCMD)	R/W
0x0007	Flash Control Register (FCTL)	R
0x0008	Flash High Address Register (FADDRHI) ¹	R
0x0009	Flash Low Address Register (FADDRLO) ¹	R
0x000A	Flash High Data Register (FDATAHI)	R
0x000B	Flash Low Data Register (FDATALO)	R
0x000C	RESERVED1 ¹	R
0x000D	RESERVED2 ¹	R
0x000E	RESERVED3 ¹	R
0x000F	RESERVED4 ¹	R

¹ Intended for factory test purposes only.

2.3.2 Register Descriptions

Register Name		Bit 7	6	5	4	3	2	1	Bit 0
0x0000 FCLKDIV	R	FDIVLD	PRDIV8	FDIV5	FDIV4	FDIV3	FDIV2	FDIV1	FDIV0
	W								
0x0001 FSEC	R	KEYEN		RNV5	RNV4	RNV3	RNV2	SEC	
	W								
0x0002 FTSTMOD	R	0	0	0	WRALL	0	0	0	0
	W								
0x0003 FCNFG	R	CBEIE	CCIE	KEYACC	0	0	0	0	BKSEL
	W								
0x0004 FPROT	R	FPOPEN	RNV6	FPHDIS	FPHS		FPLDIS	FPLS	
	W								
0x0005 FSTAT	R	CBEIF	CCIF	PVIOL	ACCERR	0	BLANK	0	0
	W								
0x0006 FCMD	R	0	CMDB						
	W								
0x0007 FCTL	R	NV7	NV6	NV5	NV4	NV3	NV2	NV1	NV0
	W								
0x0008 FADDRHI	R	FADDRHI							
	W								
0x0009 FADDRLO	R	FADDRLO							
	W								
0x000A FDATAHI	R	FDATAHI							
	W								
0x000B FDATALO	R	FDATALO							
	W								
0x000C RESERVED1	R	0	0	0	0	0	0	0	0
	W								

= Unimplemented or Reserved

Figure 2-3. FTS256K2 Register Summary

Register Name		Bit 7	6	5	4	3	2	1	Bit 0
0x000D RESERVED2	R	0	0	0	0	0	0	0	0
	W								
0x000E RESERVED3	R	0	0	0	0	0	0	0	0
	W								
0x000F RESERVED4	R	0	0	0	0	0	0	0	0
	W								

= Unimplemented or Reserved

Figure 2-3. FTS256K2 Register Summary (continued)

2.3.2.1 Flash Clock Divider Register (FCLKDIV)

The unbanked FCLKDIV register is used to control timed events in program and erase algorithms.

Module Base + 0x0000

	7	6	5	4	3	2	1	0
R	FDIVLD	PRDIV8	FDIV5	FDIV4	FDIV3	FDIV2	FDIV1	FDIV0
W								
Reset	0	0	0	0	0	0	0	0

= Unimplemented or Reserved

Figure 2-4. Flash Clock Divider Register (FCLKDIV)

All bits in the FCLKDIV register are readable, bits 6-0 are write once and bit 7 is not writable.

Table 2-5. FCLKDIV Field Descriptions

Field	Description
7 FDIVLD	Clock Divider Loaded. 0 Register has not been written. 1 Register has been written to since the last reset.
6 PRDIV8	Enable Prescalar by 8. 0 The oscillator clock is directly fed into the clock divider. 1 The oscillator clock is divided by 8 before feeding into the clock divider.
5-0 FDIV[5:0]	Clock Divider Bits — The combination of PRDIV8 and FDIV[5:0] must divide the oscillator clock down to a frequency of 150 kHz–200 kHz. The maximum divide ratio is 512. Please refer to Section 2.4.1.1, “Writing the FCLKDIV Register” for more information.

2.3.2.2 Flash Security Register (FSEC)

The unbanked FSEC register holds all bits associated with the security of the MCU and Flash module.

Module Base + 0x0001

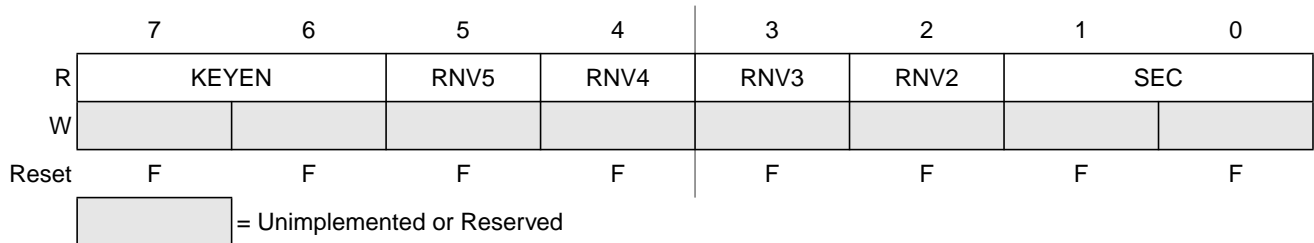

Figure 2-5. Flash Security Register (FSEC)

All bits in the FSEC register are readable but are not writable.

The FSEC register is loaded from the Flash Configuration Field at address \$FF0F during the reset sequence, indicated by F in [Figure 2-5](#).

Table 2-6. FSEC Field Descriptions

Field	Description
1-0 KEYEN[1:0]	Backdoor Key Security Enable Bits —The KEYEN[1:0] bits define the enabling of backdoor key access to the Flash module as shown in Table 2-7 .
5-2 RNV[5:2]	Reserved Nonvolatile Bits — The RNV[5:2] bits must remain in the erased 1 state for future enhancements.
1-0 SEC[1:0]	Flash Security Bits — The SEC[1:0] bits define the security state of the MCU as shown in Table 2-8 . If the Flash module is unsecured using backdoor key access, the SEC bits are forced to 10.

Table 2-7. Flash KEYEN States

KEYEN[1:0]	Status of Backdoor Key Access
00	DISABLED
01 ¹	DISABLED
10	ENABLED
11	DISABLED

¹ Preferred KEYEN state to disable Backdoor Key Access.

Table 2-8. Flash Security States

SEC[1:0]	Status of Security
00	SECURED
01 ¹	SECURED
10	UNSECURED
11	SECURED

¹ Preferred SEC state to set MCU to secured state.

The security function in the Flash module is described in [Section 2.6, “Flash Module Security”](#).

2.3.2.3 Flash Test Mode Register (FTSTMOD)

The unbanked FTSTMOD register is used to control Flash test features.

Module Base + 0x0002

	7	6	5	4	3	2	1	0
R	0	0	0	WRALL	0	0	0	0
W								
Reset	0	0	0	0	0	0	0	0

= Unimplemented or Reserved

Figure 2-6. Flash Test Mode Register (FTSTMOD)

All bits read 0 and are not writable in normal mode. The WRALL bit is writable only in special mode to simplify mass erase and erase verify operations. When writing to the FTSTMOD register in special mode, all unimplemented/reserved bits must be written to 0.

Table 2-9. FTSTMOD Field Descriptions

Field	Description
4 WRALL	Write to All Register Banks — If the WRALL bit is set, all banked registers sharing the same register address will be written simultaneously during a register write. 0 Write only to the bank selected via BKSEL. 1 Write to all register banks.

2.3.2.4 Flash Configuration Register (FCNFG)

The unbanked FCNFG register enables the Flash interrupts and gates the security backdoor writes.

Module Base + 0x0003

	7	6	5	4	3	2	1	0
R	CBEIE	CCIE	KEYACC	0	0	0	0	BKSEL
W								
Reset	0	0	0	0	0	0	0	0

= Unimplemented or Reserved

Figure 2-7. Flash Configuration Register (FCNFG)

CBEIE, CCIE, KEYACC and BKSEL bits are readable and writable while all remaining bits read 0 and are not writable. KEYACC is only writable if KEYEN (see [Section 2.3.2.2](#)) is set to the enabled state.

Table 2-10. FCNFG Field Descriptions

Field	Description
7 CBEIE	Command Buffer Empty Interrupt Enable — The CBEIE bit enables an interrupt in case of an empty command buffer in the Flash module. 0 Command buffer empty interrupt disabled. 1 An interrupt will be requested whenever the CBEIF flag (see Section 2.3.2.7, “Flash Status Register (FSTAT)”) is set.
6 CCIE	Command Complete Interrupt Enable — The CCIE bit enables an interrupt in case all commands have been completed in the Flash module. 0 Command complete interrupt disabled. 1 An interrupt will be requested whenever the CCIF flag (see Section 2.3.2.7, “Flash Status Register (FSTAT)”) is set.
5 KEYACC	Enable Security Key Writing 0 Flash writes are interpreted as the start of a command write sequence. 1 Writes to Flash array are interpreted as keys to open the backdoor. Reads of the Flash array return invalid data.
0 BKSEL	Block Select — The BKSEL bit indicates which register bank is active. 0 Select register bank associated with Flash block 0. 1 Select register bank associated with Flash block 1.

2.3.2.5 Flash Protection Register (FPROT)

The banked FPROT register defines which Flash sectors are protected against program or erase operations.

Module Base + 0x0004

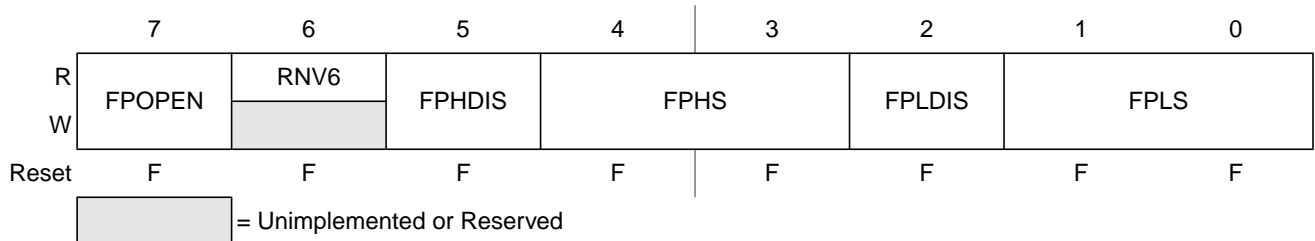

Figure 2-8. Flash Protection Register (FPROT)

All bits in the FPROT register are readable and writable with restrictions except for RNV[6] which is only readable (see [Section 2.3.2.6, “Flash Protection Restrictions”](#)).

During reset, the banked FPROT registers are loaded from the Flash Configuration Field at the address shown in [Table 2-11](#). To change the Flash protection that will be loaded during the reset sequence, the upper sector of the Flash memory must be unprotected, then the Flash Protect/Security byte located as described in [Table 2-2](#) must be reprogrammed.

Table 2-11. Reset Loading of FPROT

Flash Address	Protection Byte for
0xFF0D	Flash Block 0
0xFF0C	Flash Block 1

Trying to alter data in any of the protected areas in the Flash block will result in a protection violation error and the PVIOL flag will be set in the FSTAT register. A mass erase of the Flash block is not possible if any of the contained Flash sectors are protected.

Table 2-12. FPROT Field Descriptions

Field	Description
7 FPOPEN	Protection Function Bit — The FPOPEN bit determines the protection function for program or erase as shown in Table 2-13 . 0 FPHDIS and FPLDIS bits define unprotected address ranges as specified by the corresponding FPHS[1:0] and FPLS[1:0] bits. For an MCU without an EEPROM module, the FPOPEN clear state allows the main part of the Flash block to be protected while a small address range can remain unprotected for EEPROM emulation. 1 FPHDIS and FPLDIS bits enable protection for the address range specified by the corresponding FPHS[1:0] and FPLS[1:0] bits.
6 RNV[6]	Reserved Nonvolatile Bit — The RNV[6] bit must remain in the erased state 1 for future enhancements.
5 FPHDIS	Flash Protection Higher Address Range Disable — The FPHDIS bit determines whether there is a protected/unprotected area in the higher address space of the Flash block. 0 Protection/Unprotection enabled 1 Protection/Unprotection disabled
4:3 FPHS[1:0]	Flash Protection Higher Address Size — The FPHS[1:0] bits determine the size of the protected/unprotected area as shown in Table 2-14 . The FPHS[1:0] bits can only be written to while the FPHDIS bit is set.
2 FPLDIS	Flash Protection Lower address range Disable — The FPLDIS bit determines whether there is a protected/unprotected area in the lower address space of the Flash block. 0 Protection/Unprotection enabled 1 Protection/Unprotection disabled
1:0 FPLS[1:0]	Flash Protection Lower Address Size — The FPLS[1:0] bits determine the size of the protected/unprotected area as shown in Table 2-15 . The FPLS[1:0] bits can only be written to while the FPLDIS bit is set.

Table 2-13. Flash Protection Function

FPOPEN	FPHDIS	FPLDIS	Function ¹
1	1	1	No Protection
1	1	0	Protected Low Range
1	0	1	Protected High Range
1	0	0	Protected High and Low Ranges
0	1	1	Full Block Protected
0	1	0	Unprotected Low Range
0	0	1	Unprotected High Range
0	0	0	Unprotected High and Low Ranges

¹ For range sizes, refer to [Table 2-14](#) and [Table 2-15](#).

Table 2-14. Flash Protection Higher Address Range

FPHS[1:0]	Unpaged Address Range	Paged Address Range	Protected Size
00	0xF800–0xFFFF	0x0037/0x003F: 0xC800–0xCFFF	2 Kbytes
01	0xF000–0xFFFF	0x0037/0x003F: 0xC000–0xCFFF	4 Kbytes
10	0xE000–0xFFFF	0x0037/0x003F: 0xB000–0xCFFF	8 Kbytes
11	0xC000–0xFFFF	0x0037/0x003F: 0x8000–0xCFFF	16 Kbytes

Table 2-15. Flash Protection Lower Address Range

FPLS[1:0]	Unpaged Address Range	Paged Address Range	Protected Size
00	0x4000–0x43FF	0x0036/0x003E: 0x8000–0x83FF	1 Kbyte
01	0x4000–0x47FF	0x0036/0x003E: 0x8000–0x87FF	2 Kbytes
10	0x4000–0x4FFF	0x0036/0x003E: 0x8000–0x8FFF	4 Kbytes
11	0x4000–0x5FFF	0x0036/0x003E: 0x8000–0x9FFF	8 Kbytes

All possible Flash protection scenarios are illustrated in [Figure 2-9](#). Although the protection scheme is loaded from the Flash array after reset, it can be changed by the user. This protection scheme can be used by applications requiring re-programming in single-chip mode while providing as much protection as possible if re-programming is not required.

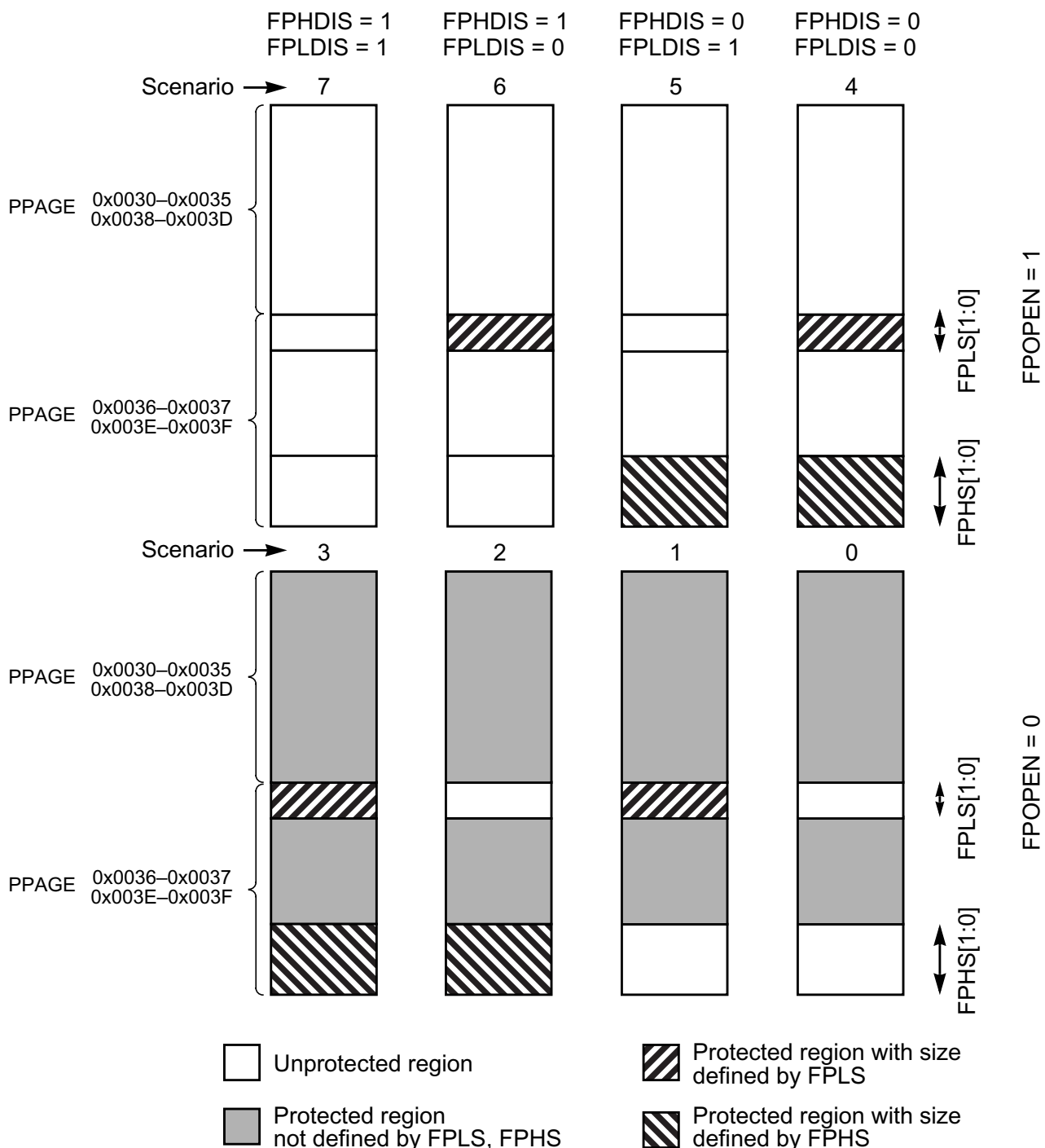

Figure 2-9. Flash Protection Scenarios

2.3.2.6 Flash Protection Restrictions

The general guideline is that Flash protection can only be added and not removed. [Table 2-16](#) specifies all valid transitions between Flash protection scenarios. Any attempt to write an invalid scenario to the FPROT register will be ignored and the FPROT register will remain unchanged. The contents of the

FPROT register reflect the active protection scenario. See the FPHS and FPLS descriptions for additional restrictions.

Table 2-16. Flash Protection Scenario Transitions

From Protection Scenario	To Protection Scenario ¹							
	0	1	2	3	4	5	6	7
0	X	X	X	X				
1		X		X				
2			X	X				
3				X				
4				X	X			
5			X	X	X	X		
6		X		X	X		X	
7	X	X	X	X	X	X	X	X

¹ Allowed transitions marked with X.

2.3.2.7 Flash Status Register (FSTAT)

The banked FSTAT register defines the operational status of the module.

Module Base + 0x0005

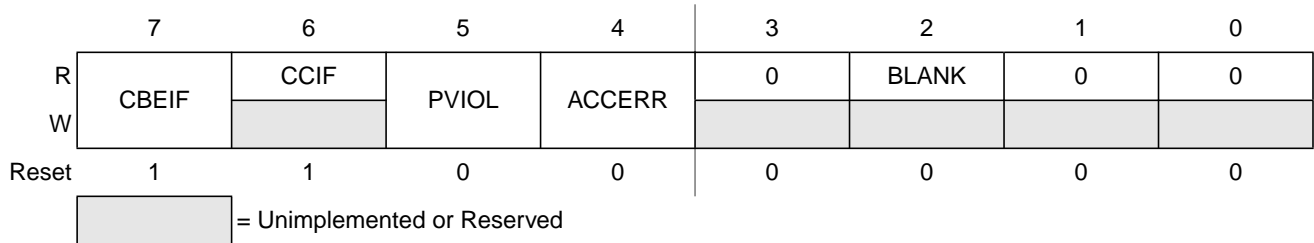

Figure 2-10. Flash Status Register (FSTAT - Normal Mode)

Module Base + 0x0005

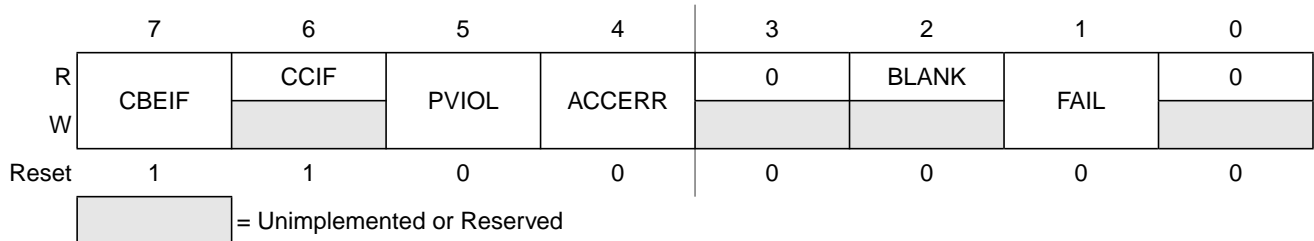

Figure 2-11. Flash Status Register (FSTAT - Special Mode)

CBEIF, PVIOL, and ACCERR are readable and writable, CCIF and BLANK are readable and not writable, remaining bits read 0 and are not writable in normal mode. FAIL is readable and writable in special mode. FAIL must be clear in the current banked FSTAT register when starting a command write sequence.

Table 2-17. FSTAT Field Descriptions

Field	Description
7 CBEIF	<p>Command Buffer Empty Interrupt Flag — The CBEIF flag indicates that the address, data and command buffers are empty so that a new command write sequence can be started. The CBEIF flag is cleared by writing a 1 to CBEIF. Writing a 0 to the CBEIF flag has no effect on CBEIF. Writing a 0 to CBEIF after writing an aligned word to the Flash address space but before CBEIF is cleared will abort a command write sequence and cause the ACCERR flag to be set. Writing a 0 to CBEIF outside of a command write sequence will not set the ACCERR flag. The CBEIF flag is used together with the CBEIE bit in the FCNFG register to generate an interrupt request (see Figure 2-30).</p> <p>0 Buffers are full. 1 Buffers are ready to accept a new command.</p>
6 CCIF	<p>Command Complete Interrupt Flag — The CCIF flag indicates that there are no more commands pending. The CCIF flag is cleared when CBEIF is clear and sets automatically upon completion of all active and pending commands. The CCIF flag does not set when an active commands completes and a pending command is fetched from the command buffer. Writing to the CCIF flag has no effect on CCIF. The CCIF flag is used together with the CCIE bit in the FCNFG register to generate an interrupt request (see Figure 2-30).</p> <p>0 Command in progress. 1 All commands are completed.</p>
5 PVIOL	<p>Protection Violation Flag — The PVIOL flag indicates an attempt was made to program or erase an address in a protected area of the Flash block during a command write sequence. The PVIOL flag is cleared by writing a 1 to PVIOL. Writing a 0 to the PVIOL flag has no effect on PVIOL. While PVIOL is set in any of the banked FTSAT registers, it is not possible to launch a command or start a command write sequence in any of the Flash blocks.</p> <p>0 No failure. 1 A protection violation has occurred.</p>
4 ACCERR	<p>Access Error Flag — The ACCERR flag indicates an illegal access to the Flash array caused by either a violation of the command write sequence, issuing an illegal command (illegal combination of the CMDBx bits in the FCMD register), launching the sector erase abort command terminating a sector erase operation early or the execution of a CPU STOP instruction while a command is executing (CCIF = 0). The ACCERR flag is cleared by writing a 1 to ACCERR. Writing a 0 to the ACCERR flag has no effect on ACCERR. While ACCERR is set in any of the banked FTSAT registers, it is not possible to launch a command or start a command write sequence in any of the Flash blocks. If ACCERR is set by an erase verify operation or a data compress operation, any buffered command will not launch.</p> <p>0 No access error detected. 1 Access error has occurred.</p>
2 BLANK	<p>Erase Verify Operation Status Flag — When the CCIF flag is set after completion of an erase verify command, the BLANK flag indicates the result of the erase verify operation. The BLANK flag is cleared by the Flash module when CBEIF is cleared as part of a new valid command write sequence. Writing to the BLANK flag has no effect on BLANK.</p> <p>0 Flash block verified as not erased. 1 Flash block verified as erased.</p>
1 FAIL	<p>Flag Indicating a Failed Flash Operation — The FAIL flag will set if the erase verify operation fails (selected Flash block verified as not erased). The FAIL flag is cleared by writing a 1 to FAIL. Writing a 0 to the FAIL flag has no effect on FAIL. While FAIL is set in the current banked FTSAT register, it is not possible to launch a command in the selected Flash block.</p> <p>0 Flash operation completed without error. 1 Flash operation failed.</p>

2.3.2.8 Flash Command Register (FCMD)

The banked FCMD register is the Flash command register.

Module Base + 0x0006

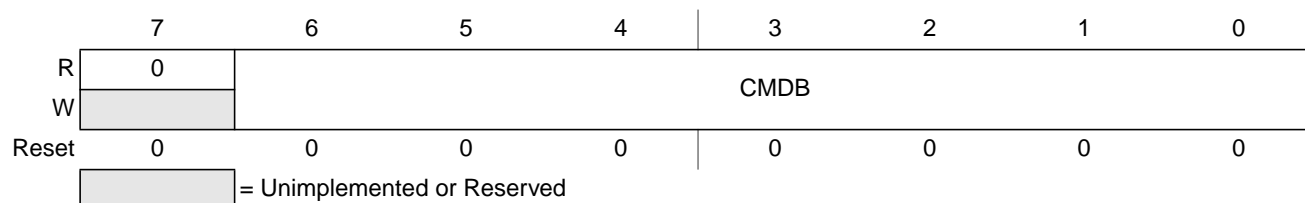

Figure 2-12. Flash Command Register (FCMD - NVM User Mode)

All CMDB bits are readable and writable during a command write sequence while bit 7 reads 0 and is not writable.

Table 2-18. FCMD Field Descriptions

Field	Description
6-0 CMDB[6:0]	Flash Command — Valid Flash commands are shown in Table 2-19 . Writing any command other than those listed in Table 2-19 sets the ACCERR flag in the FSTAT register.

Table 2-19. Valid Flash Command List

CMDB[6:0]	NVM Command
0x05	Erase Verify
0x06	Data Compress
0x20	Word Program
0x40	Sector Erase
0x41	Mass Erase
0x47	Sector Erase Abort

2.3.2.9 Flash Control Register (FCTL)

The banked FCTL register is the Flash control register.

Module Base + 0x0007

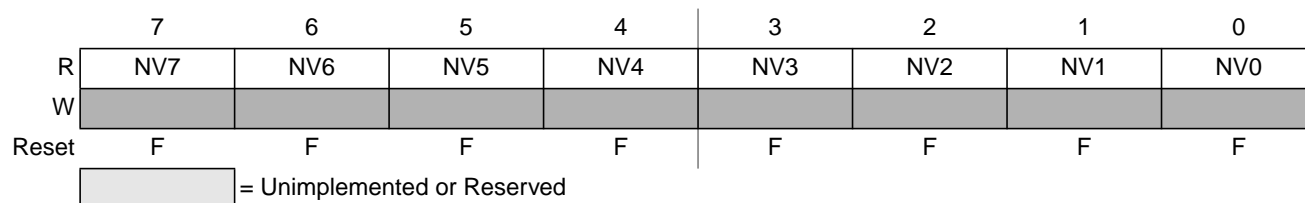

Figure 2-13. Flash Control Register (FCTL)

All bits in the FCTL register are readable but are not writable.

The FCTL register is loaded from the Flash Configuration Field byte at \$FF0E during the reset sequence, indicated by F in [Figure 2-13](#).

Table 2-20. FCTL Field Descriptions

Field	Description
7-0 NV[7:0]	Nonvolatile Bits — The NV[7:0] bits are available as nonvolatile bits. Refer to the Device User Guide for proper use of the NV bits.

2.3.2.10 Flash Address Registers (FADDR)

The banked FADDRHI and FADDRLO registers are the Flash address registers.

Module Base + 0x0008

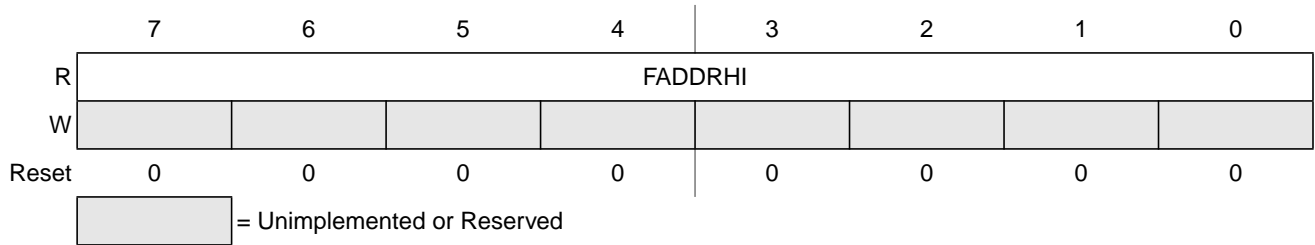

Figure 2-14. Flash Address High Register (FADDRHI)

Module Base + 0x0009

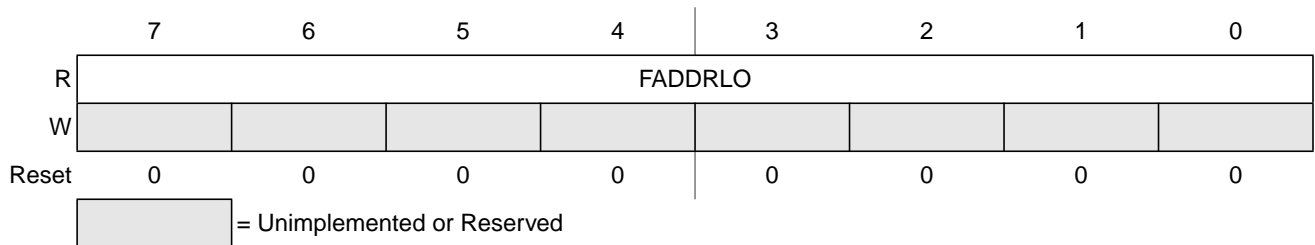

Figure 2-15. Flash Address Low Register (FADDRLO)

All FADDRHI and FADDRLO bits are readable but are not writable. After an array write as part of a command write sequence, the FADDR registers will contain the mapped MCU address written.

2.3.2.11 Flash Data Registers (FDATA)

The banked FDATAHI and FDATALO registers are the Flash data registers.

Module Base + 0x000A

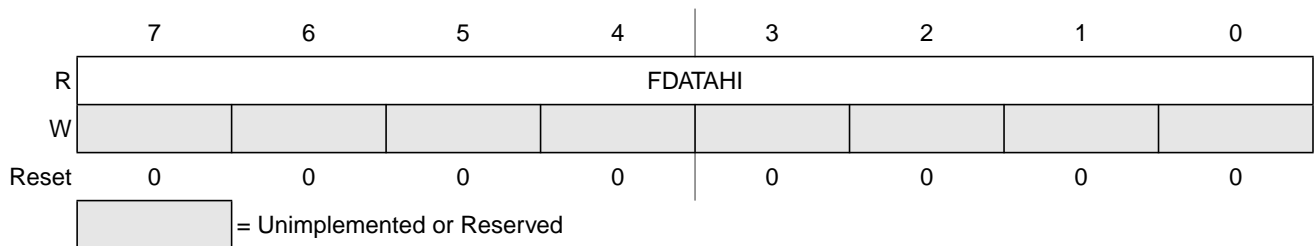

Figure 2-16. Flash Data High Register (FDATAHI)

Module Base + 0x000B

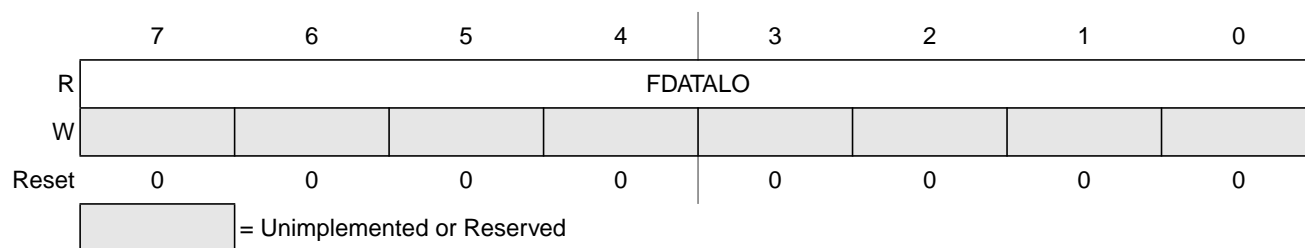

Figure 2-17. Flash Data Low Register (FDATALO)

All FDATAHI and FDATALO bits are readable but are not writable. After an array write as part of a command write sequence, the FDATA registers will contain the data written. At the completion of a data compress operation, the resulting 16-bit signature is stored in the FDATA registers. The data compression signature is readable in the FDATA registers until a new command write sequence is started.

2.3.2.12 RESERVED1

This register is reserved for factory testing and is not accessible.

Module Base + 0x000C

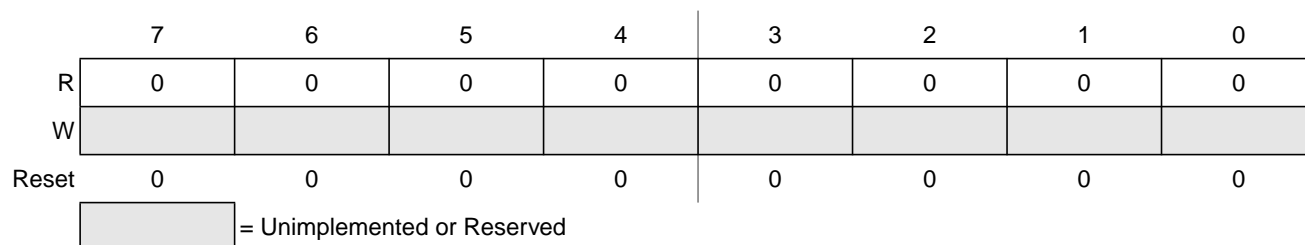

Figure 2-18. RESERVED1

All bits read 0 and are not writable.

2.3.2.13 RESERVED2

This register is reserved for factory testing and is not accessible.

Module Base + 0x000D

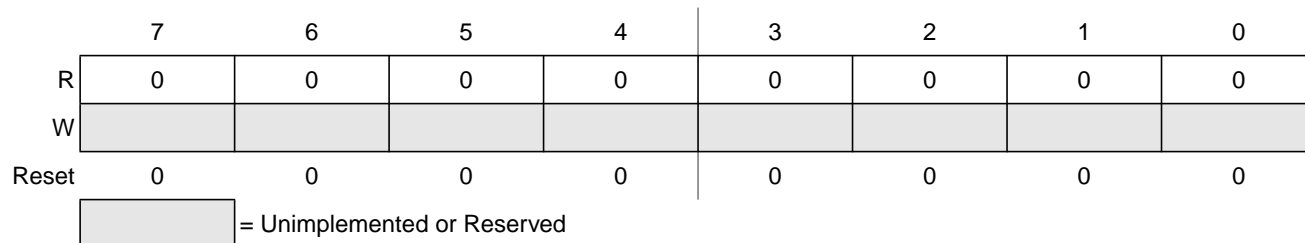

Figure 2-19. RESERVED2

All bits read 0 and are not writable.

2.3.2.14 RESERVED3

This register is reserved for factory testing and is not accessible.

Module Base + 0x000E

	7	6	5	4	3	2	1	0
R	0	0	0	0	0	0	0	0
W								
Reset	0	0	0	0	0	0	0	0

= Unimplemented or Reserved

Figure 2-20. RESERVED3

All bits read 0 and are not writable.

2.3.2.15 RESERVED4

This register is reserved for factory testing and is not accessible.

Module Base + 0x000F

	7	6	5	4	3	2	1	0
R	0	0	0	0	0	0	0	0
W								
Reset	0	0	0	0	0	0	0	0

= Unimplemented or Reserved

Figure 2-21. RESERVED4

All bits read 0 and are not writable.

2.4 Functional Description

2.4.1 Flash Command Operations

Write and read operations are both used for the program, erase, erase verify, and data compress algorithms described in this subsection. The program and erase algorithms are time controlled by a state machine whose timebase, FCLK, is derived from the oscillator clock via a programmable divider. The command register as well as the associated address and data registers operate as a buffer and a register (2-stage FIFO) so that a second command along with the necessary data and address can be stored to the buffer while the first command remains in progress. This pipelined operation allows a time optimization when programming more than one word on a specific row in the Flash block as the high voltage generation can be kept active in between two programming commands. The pipelined operation also allows a simplification of command launching. Buffer empty as well as command completion are signalled by flags in the Flash status register with interrupts generated, if enabled.

The next paragraphs describe:

1. How to write the FCLKDIV register.
2. Command write sequences used to program, erase, and verify the Flash memory.
3. Valid Flash commands.
4. Effects resulting from illegal Flash command write sequences or aborting Flash operations.

2.4.1.1 Writing the FCLKDIV Register

Prior to issuing any program, erase, erase verify, or data compress command, it is first necessary to write the FCLKDIV register to divide the oscillator clock down to within the 150 kHz to 200 kHz range. Because the program and erase timings are also a function of the bus clock, the FCLKDIV determination must take this information into account.

If we define:

- FCLK as the clock of the Flash timing control block,
- Tbus as the period of the bus clock, and
- INT(x) as taking the integer part of x (e.g. INT(4.323)=4).

Then, FCLKDIV register bits PRDIV8 and FDIV[5:0] are to be set as described in [Figure 2-22](#).

For example, if the oscillator clock frequency is 950 kHz and the bus clock frequency is 10 MHz, FCLKDIV bits FDIV[5:0] must be set to 4 (000100) and bit PRDIV8 set to 0. The resulting FCLK frequency is then 190 kHz. As a result, the Flash program and erase algorithm timings are increased over the optimum target by:

$$(200 - 190) / 200 \cdot 100 = 5\%$$

CAUTION

Program and erase command execution time will increase proportionally with the period of FCLK. Because of the impact of clock synchronization on the accuracy of the functional timings, programming or erasing the Flash memory cannot be performed if the bus clock runs at less than 1 MHz. Programming or erasing the Flash memory with $FCLK < 150$ kHz must be avoided. Setting FCLKDIV to a value such that $FCLK < 150$ kHz can destroy the Flash memory due to overstress. Setting FCLKDIV to a value such that $(1/FCLK + T_{bus}) < 5\mu s$ can result in incomplete programming or erasure of the Flash memory cells.

If the FCLKDIV register is written, the FDIVLD bit is set automatically. If the FDIVLD bit is 0, the FCLKDIV register has not been written since the last reset. Flash commands will not be executed if the FCLKDIV register has not been written to.

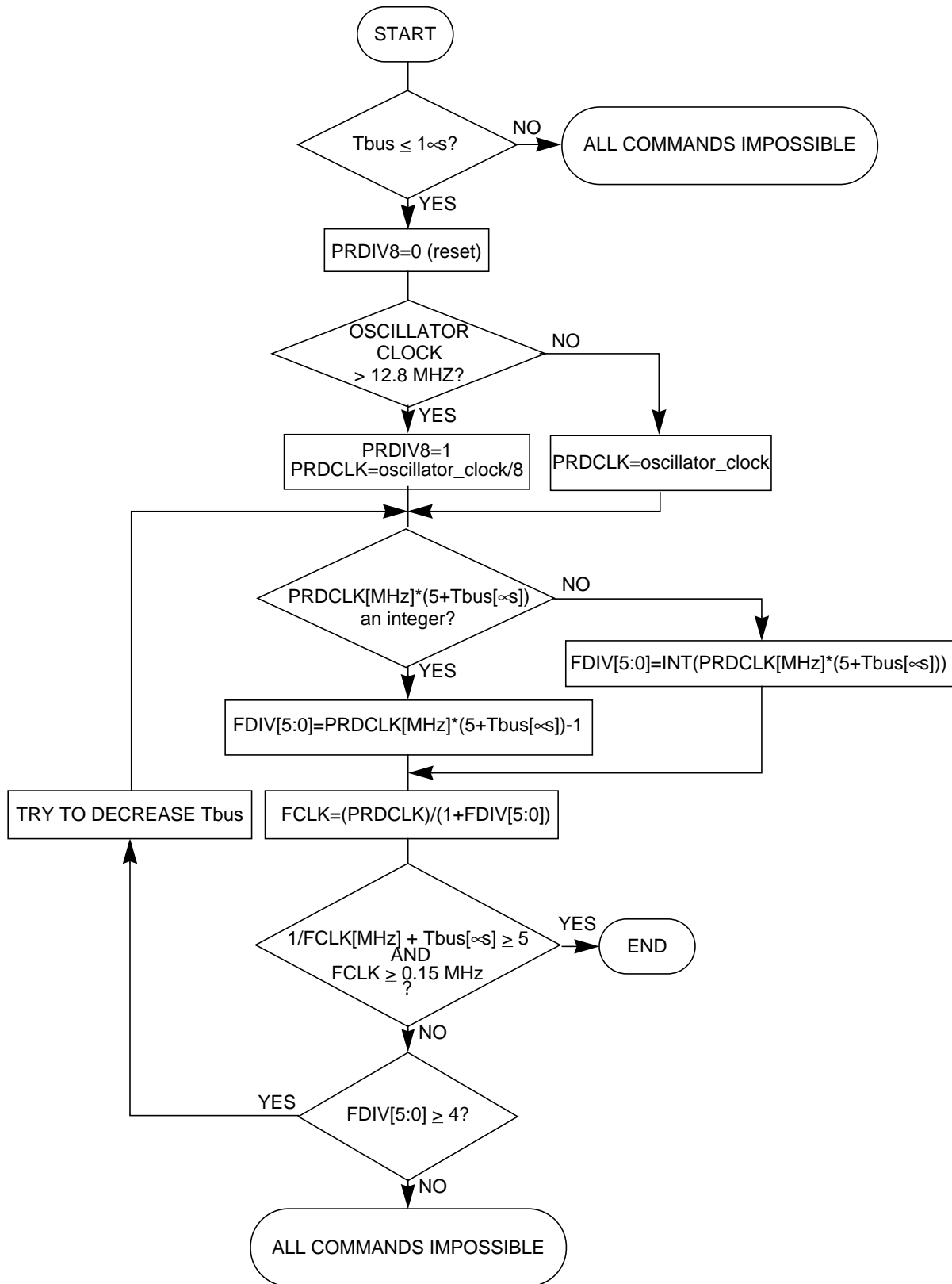

Figure 2-22. Determination Procedure for PRDIV8 and FDIV Bits

2.4.1.2 Command Write Sequence

The Flash command controller is used to supervise the command write sequence to execute program, erase, erase verify, and data compress algorithms.

Before starting a command write sequence, the ACCERR, PVIOL, and FAIL flags must be clear in all of the banked FSTAT registers (see [Section 2.3.2.7, “Flash Status Register \(FSTAT\)”](#)) and the CBEIF flag must be tested to determine the state of the address, data, and command buffers. If the CBEIF flag is set, indicating the buffers are empty, a new command write sequence can be started. If the CBEIF flag is clear, indicating the buffers are not available, a new command write sequence will overwrite the contents of the address, data, and command buffers.

A command write sequence consists of three steps which must be strictly adhered to with writes to the Flash module not permitted between the steps. However, Flash register and array reads are allowed during a command write sequence. A command write sequence consists of the following steps:

1. Write an aligned data word to a valid Flash array address. The address and data will be stored in the address and data buffers, respectively. If the CBEIF flag is clear when the Flash array write occurs, the contents of the address and data buffers will be overwritten and the CBEIF flag will be set.
2. Write a valid command to the FCMD register.
 - a) For the erase verify command (see [Section 2.4.1.3.1, “Erase Verify Command”](#)), the contents of the data buffer are ignored and all address bits in the address buffer are ignored.
 - b) For the data compress command (see [Section 2.4.1.3.2, “Data Compress Command”](#)), the contents of the data buffer represents the number of consecutive words to read for data compression and the contents of the address buffer represents the starting address.
 - c) For the program command (see [Section 2.4.1.3.3, “Program Command”](#)), the contents of the data buffer will be programmed to the address specified in the address buffer with all address bits valid.
 - d) For the sector erase command (see [Section 2.4.1.3.4, “Sector Erase Command”](#)), the contents of the data buffer are ignored and address bits [9:0] contained in the address buffer are ignored.
 - e) For the mass erase command (see [Section 2.4.1.3.5, “Mass Erase Command”](#)), the contents of the data buffer and address buffer are ignored.
 - f) For the sector erase abort command (see [Section 2.4.1.3.6, “Sector Erase Abort Command”](#)), the contents of the data buffer and address buffer are ignored.
3. Clear the CBEIF flag by writing a 1 to CBEIF to launch the command. When the CBEIF flag is cleared, the CCIF flag is cleared on the same bus cycle by internal hardware indicating that the command was successfully launched. For all command write sequences except data compress and sector erase abort, the CBEIF flag will set four bus cycles after the CCIF flag is cleared indicating that the address, data, and command buffers are ready for a new command write sequence to begin. For data compress and sector erase abort operations, the CBEIF flag will remain clear until the operation completes.

A command write sequence can be aborted prior to clearing the CBEIF flag by writing a 0 to the CBEIF flag and will result in the ACCERR flag being set.

Except for the sector erase abort command, a buffered command will wait for the active operation to be completed before being launched. The sector erase abort command is launched when the CBEIF flag is cleared as part of a sector erase abort command write sequence. After a command is launched, the completion of the command operation is indicated by the setting of the CCIF flag. The CCIF flag only sets when all active and buffered commands have been completed.

2.4.1.3 Valid Flash Commands

Table 2-21 summarizes the valid Flash commands along with the effects of the commands on the Flash block.

Table 2-21. Valid Flash Command Description

FCMDB	NVM Command	Function on Flash Memory
0x05	Erase Verify	Verify all memory bytes in the Flash block are erased. If the Flash block is erased, the BLANK flag in the FSTAT register will set upon command completion.
0x06	Data Compress	Compress data from a selected portion of the Flash block. The resulting signature is stored in the FDATA register.
0x20	Program	Program a word (two bytes) in the Flash block.
0x40	Sector Erase	Erase all memory bytes in a sector of the Flash block.
0x41	Mass Erase	Erase all memory bytes in the Flash block. A mass erase of the full Flash block is only possible when FPLDIS, FPHDIS, and FOPEN bits in the FPROT register are set prior to launching the command.
0x47	Sector Erase Abort	Abort the sector erase operation. The sector erase operation will terminate according to a set procedure. The Flash sector must not be considered erased if the ACCERR flag is set upon command completion.

CAUTION

A Flash word must be in the erased state before being programmed. Cumulative programming of bits within a Flash word is not allowed.

2.4.1.3.1 Erase Verify Command

The erase verify operation is used to confirm that a Flash block is erased. After launching the erase verify command, the CCIF flag in the FSTAT register will set after the operation has completed unless a second command has been buffered. The number of bus cycles required to execute the erase verify operation is equal to the number of addresses in the Flash block plus 12 bus cycles as measured from the time the CBEIF flag is cleared until the CCIF flag is set. The result of the erase verify operation is reflected in the state of the BLANK flag in the FSTAT register. If the BLANK flag is set in the FSTAT register, the Flash memory is erased.

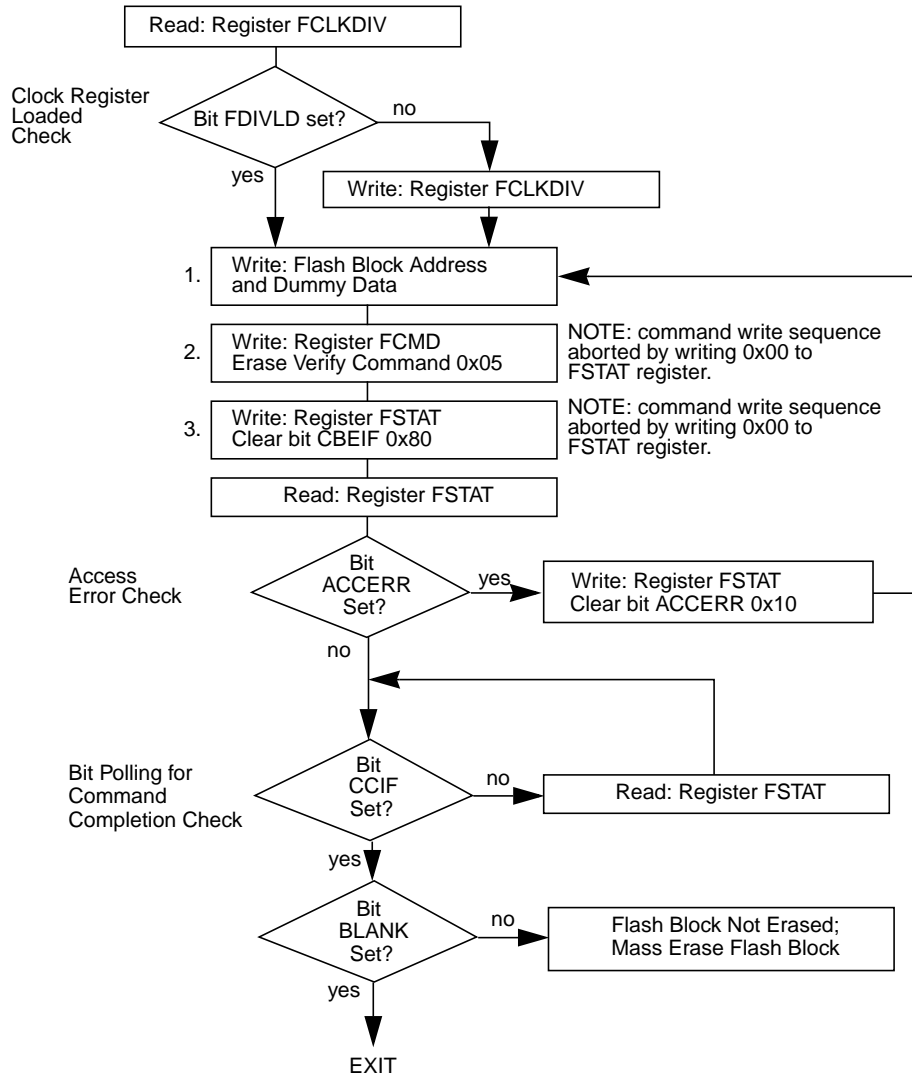

Figure 2-23. Example Erase Verify Command Flow

2.4.1.3.2 Data Compress Command

The data compress command is used to check Flash code integrity by compressing data from a selected portion of the Flash block into a signature analyzer. The starting address for the data compress operation is defined by the address written during the command write sequence. The number of consecutive word addresses compressed is defined by the data written during the command write sequence. The number of words that can be compressed in a single data compress operation ranges from 1 to 16,384. After launching the data compress command, the CCIF flag in the FSTAT register will set after the data compress operation has completed. The number of bus cycles required to execute the data compress operation is equal to two times the number of addresses read plus 20 bus cycles as measured from the time the CBEIF flag is cleared until the CCIF flag is set. After the CCIF flag is set, the signature generated by the data compress operation is available in the FDATA register. The signature in the FDATA register can be compared to the expected signature to determine the integrity of the selected data stored in the Flash block. If the last address of the Flash block is reached during the data compress operation, data compression will continue with the starting address of the Flash block.

NOTE

Since the FDATA register (or data buffer) is written to as part of the data compress operation, a command write sequence is not allowed to be buffered behind a data compress command write sequence. The CBEIF flag will not set after launching the data compress command to indicate that a command must not be buffered behind it. If an attempt is made to start a new command write sequence with a data compress operation active, the ACCERR flag in the FSTAT register will be set. A new command write sequence must only be started after reading the signature stored in the FDATA register.

In order to take corrective action, it is recommended that the data compress command be executed on a Flash sector or subset of a Flash sector. If the data compress operation on a Flash sector returns an invalid signature, the Flash sector should be erased using the sector erase command and then reprogrammed using the program command.

NOTE

During the data compress operation, the Flash array is read with a sense-amp margin setting that is different from the normal array read setting. Therefore, if the data compress operation returns an invalid signature, the section of the Flash array compressed may still be functional. The failing section of the Flash array could be validated using normal array read operations.

The data compress command can be used to verify that a sector or sequential set of sectors are erased.

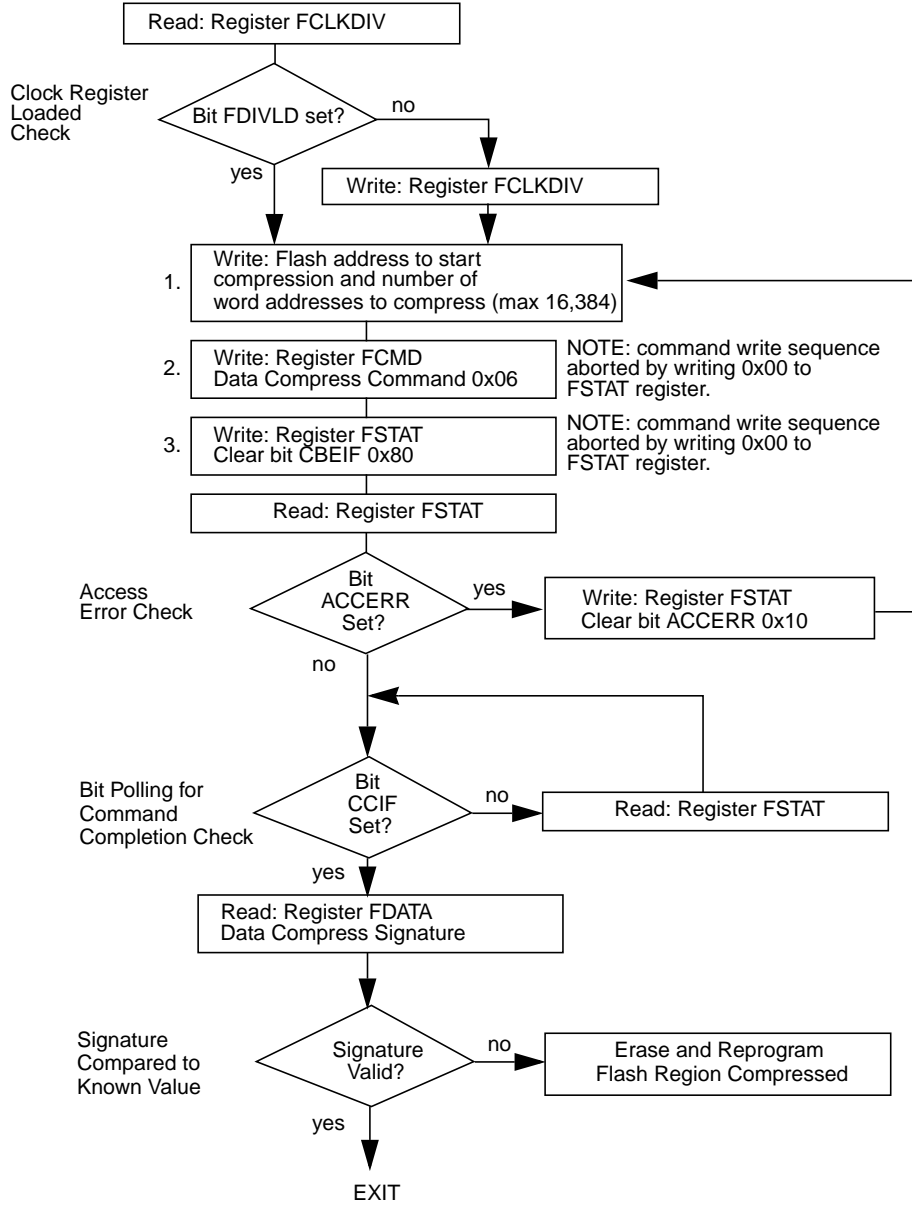

Figure 2-24. Example Data Compress Command Flow

Data Compress Operation

The Flash module contains a 16-bit multiple-input signature register (MISR) to generate a 16-bit signature based on selected Flash array data. The final signature, which is stored in the associated banked FDATA register, is based on the following logic equation which is executed on every data compression cycle during the operation:

$$\text{MISR}[15:0] = \{\text{MISR}[14:0], \wedge \text{MISR}[15,4,2,1]\} \wedge \text{DATA}[15:0] \tag{Eqn. 2-1}$$

where MISR is the content of the internal signature register associated with each Flash block and DATA is the data to be compressed as shown in Figure 2-25.

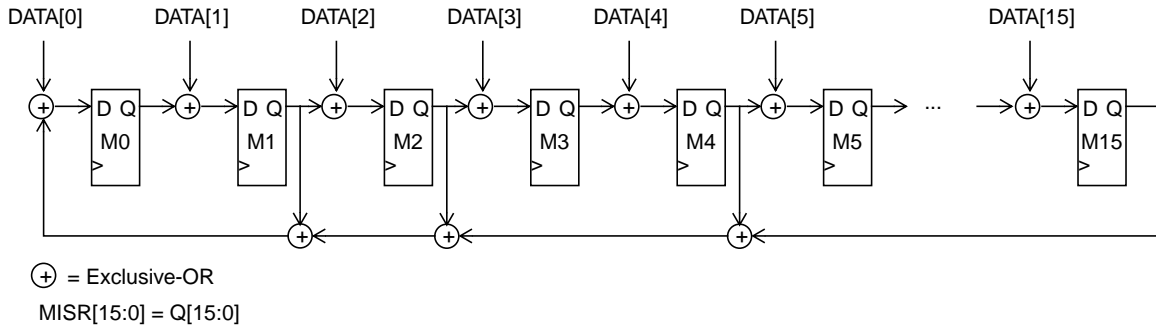

Figure 2-25. 16-Bit MISR Diagram

During the data compress operation, the following steps are executed:

1. MISR is reset to 0xFFFF.
2. DATA from the selected Flash array data range is read and compressed into the MISR with address incrementing.
3. DATA from the selected Flash array data range is read and compressed into the MISR with address decrementing.
4. The contents of the MISR are written to the associated banked FDATA register.

2.4.1.3.3 Program Command

The program command is used to program a previously erased word in the Flash memory using an embedded algorithm. If the word to be programmed is in a protected area of the Flash block, the PVIOL flag in the FSTAT register will set and the program command will not launch. After the program command has successfully launched, the CCIF flag in the FSTAT register will set after the program operation has completed unless a second command has been buffered.

A summary of the launching of a program operation is shown in [Figure 2-26](#).

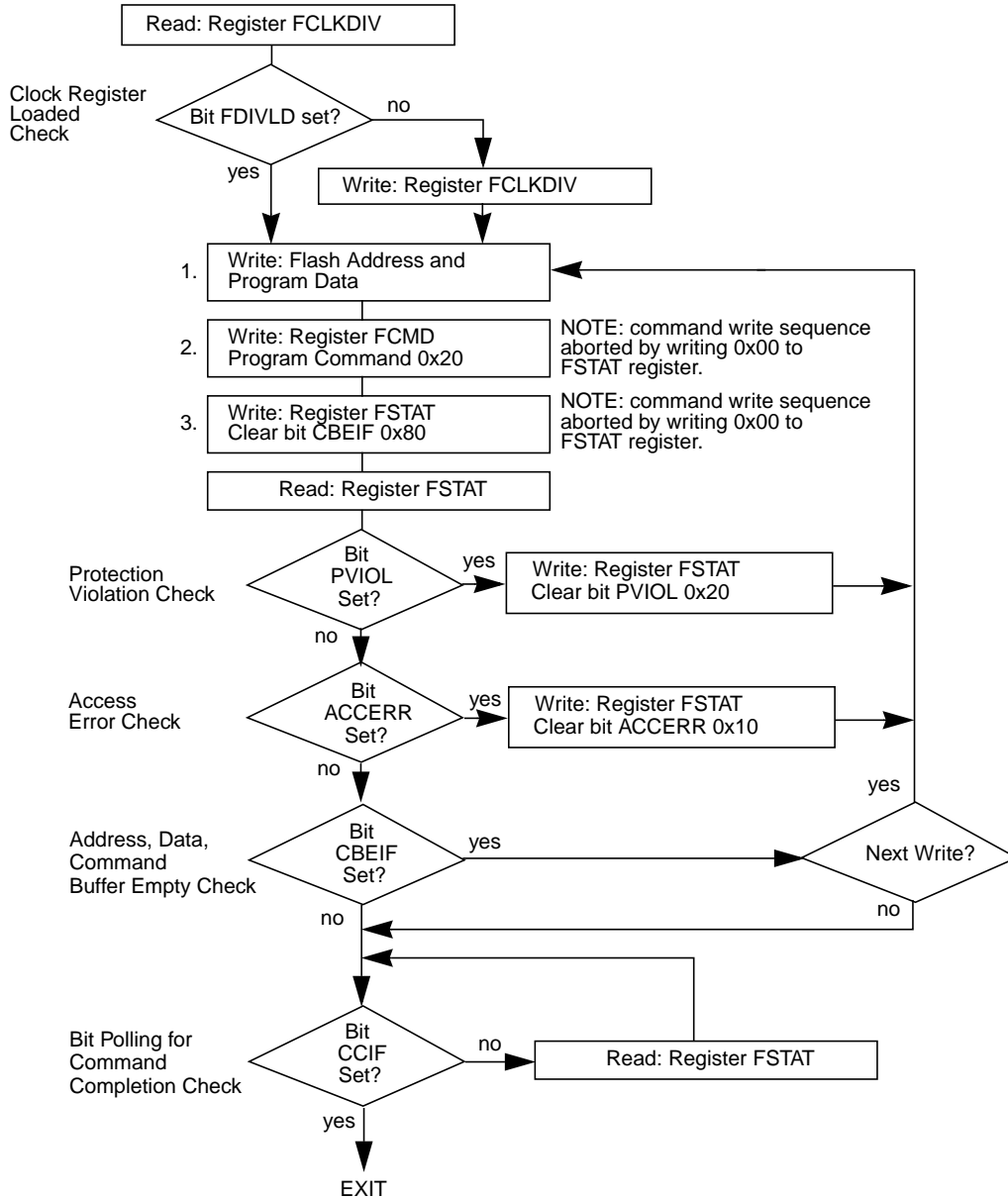

Figure 2-26. Example Program Command Flow

2.4.1.3.4 Sector Erase Command

The sector erase command is used to erase the addressed sector in the Flash memory using an embedded algorithm. If the Flash sector to be erased is in a protected area of the Flash block, the PVIOL flag in the FSTAT register will set and the sector erase command will not launch. After the sector erase command has successfully launched, the CCIF flag in the FSTAT register will set after the sector erase operation has completed unless a second command has been buffered.

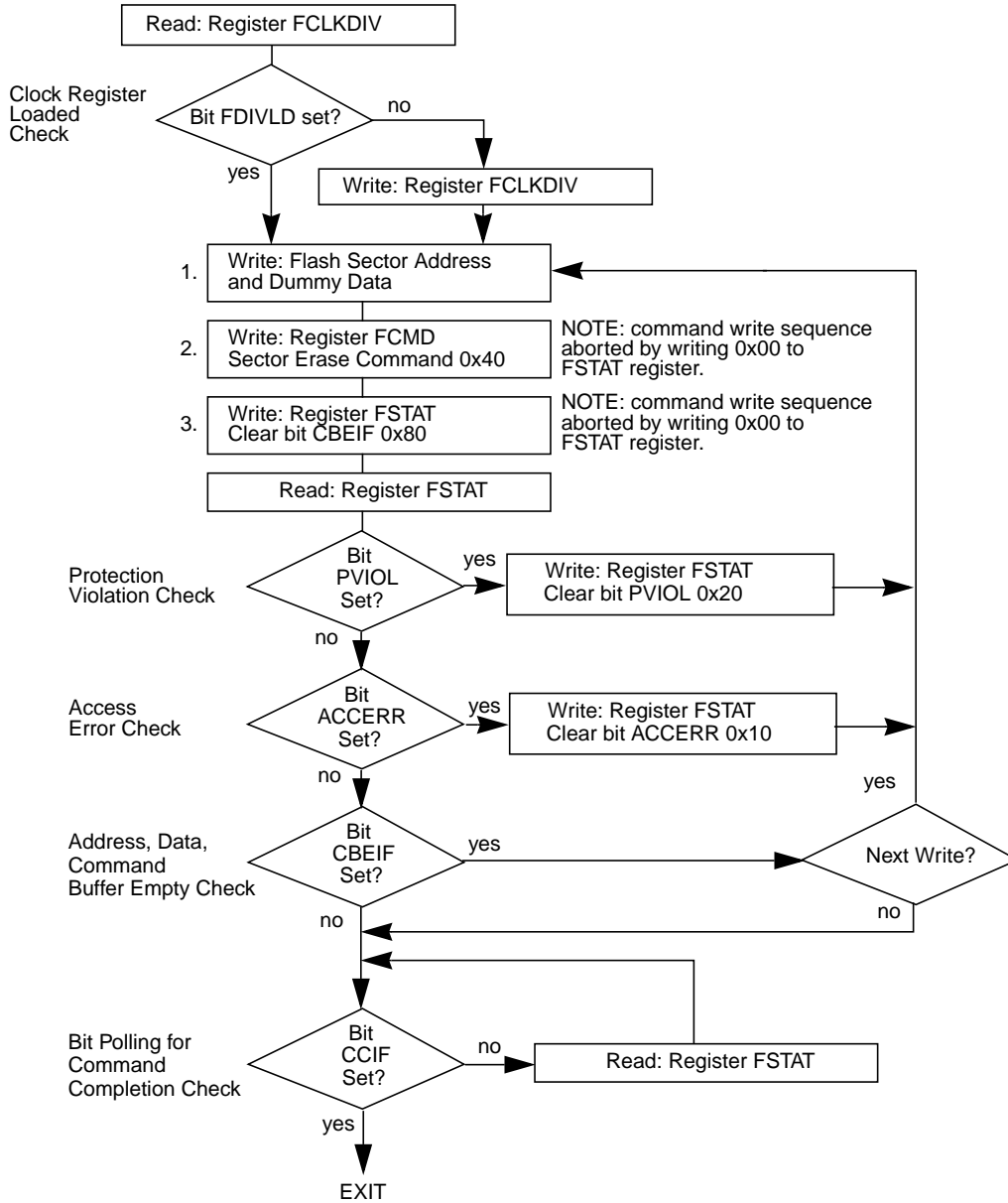

Figure 2-27. Example Sector Erase Command Flow

2.4.1.3.5 Mass Erase Command

The mass erase command is used to erase a Flash memory block using an embedded algorithm. If the Flash block to be erased contains any protected area, the PVIOL flag in the FSTAT register will set and the mass erase command will not launch. After the mass erase command has successfully launched, the CCIF flag in the FSTAT register will set after the mass erase operation has completed unless a second command has been buffered.

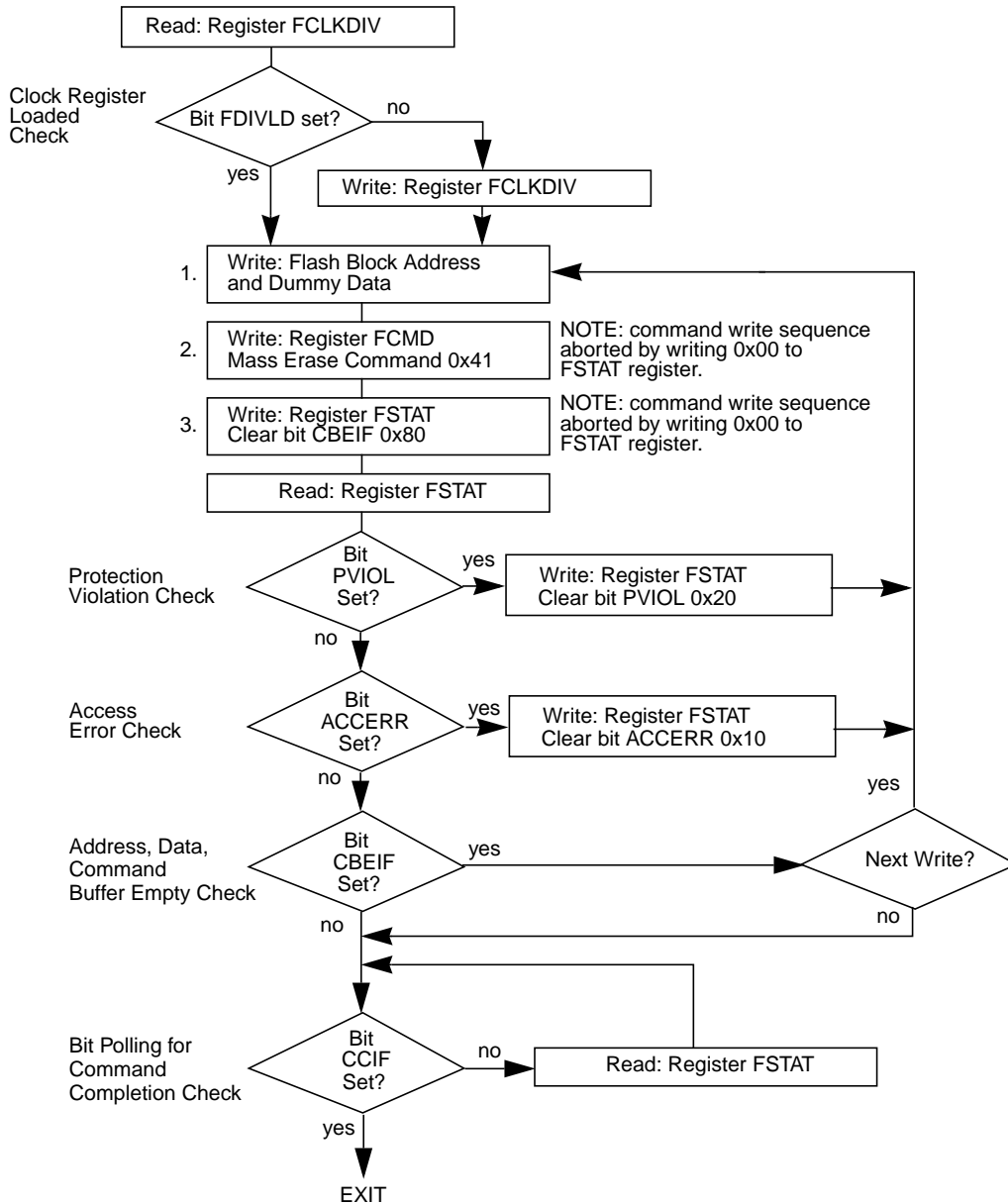

Figure 2-28. Example Mass Erase Command Flow

2.4.1.3.6 Sector Erase Abort Command

The sector erase abort command is used to terminate the sector erase operation so that other sectors in the Flash block are available for read and program operations without waiting for the sector erase operation to complete. If the sector erase abort command is launched resulting in the early termination of an active sector erase operation, the ACCERR flag will set after the operation completes as indicated by the CCIF flag being set. The ACCERR flag sets to inform the user that the sector may not be fully erased and a new sector erase command must be launched before programming any location in that specific sector. If the sector erase abort command is launched but the active sector erase operation completes normally, the ACCERR flag will not set upon completion of the operation as indicated by the CCIF flag being set. Therefore, if the ACCERR flag is not set after the sector erase abort command has completed, the sector being erased when the abort command was launched is fully erased. The maximum number of cycles required to abort a sector erase operation is equal to four FCLK periods (see [Section 2.4.1.1, “Writing the FCLKDIV Register”](#)) plus five bus cycles as measured from the time the CBEIF flag is cleared until the CCIF flag is set.

NOTE

Since the ACCERR bit in the FSTAT register may be set at the completion of the sector erase abort operation, a command write sequence is not allowed to be buffered behind a sector erase abort command write sequence. The CBEIF flag will not set after launching the sector erase abort command to indicate that a command must not be buffered behind it. If an attempt is made to start a new command write sequence with a sector erase abort operation active, the ACCERR flag in the FSTAT register will be set. A new command write sequence may be started after clearing the ACCERR flag, if set.

NOTE

The sector erase abort command must be used sparingly because a sector erase operation that is aborted counts as a complete program/erase cycle.

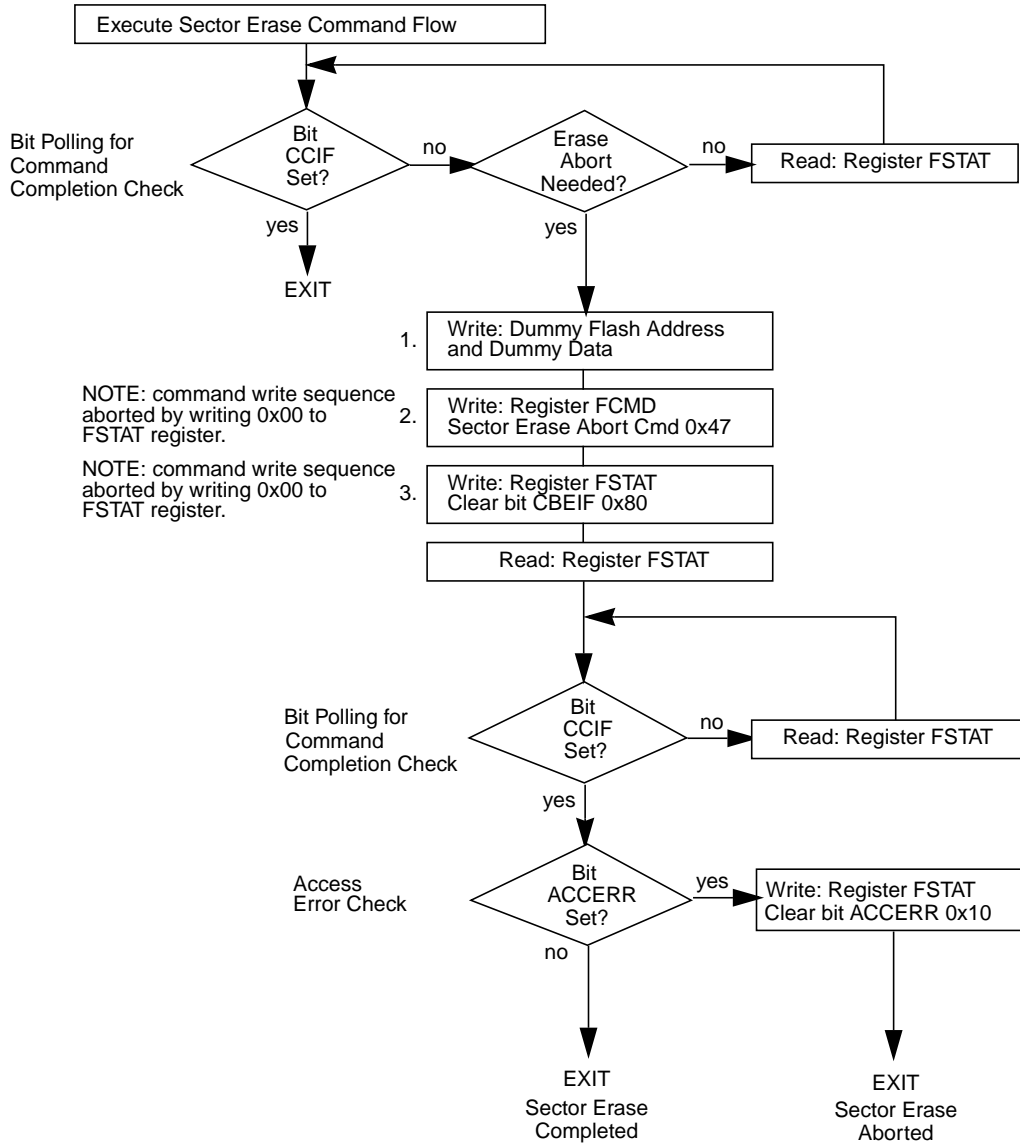

Figure 2-29. Example Sector Erase Abort Command Flow

2.4.1.4 Illegal Flash Operations

The ACCERR flag will be set during the command write sequence if any of the following illegal steps are performed, causing the command write sequence to immediately abort:

1. Writing to a Flash address before initializing the FCLKDIV register.
2. Writing to a Flash address in the range 0x8000–0xBFFF when the PPAGE register does not select a 16 Kbyte page in the Flash block selected by the BKSEL bit in the FCNFG register.
3. Writing to a Flash address in the range 0x4000–0x7FFF or 0xC000–0xFFFF with the BKSEL bit in the FCNFG register not selecting Flash block 0.
4. Writing a byte or misaligned word to a valid Flash address.
5. Starting a command write sequence while a data compress operation is active.
6. Starting a command write sequence while a sector erase abort operation is active.
7. Writing a second word to a Flash address in the same command write sequence.
8. Writing to any Flash register other than FCMD after writing a word to a Flash address.
9. Writing a second command to the FCMD register in the same command write sequence.
10. Writing an invalid command to the FCMD register.
11. When security is enabled, writing a command other than mass erase to the FCMD register when the write originates from a non-secure memory location or from the Background Debug Mode.
12. Writing to any Flash register other than FSTAT (to clear CBEIF) after writing to the FCMD register.
13. Writing a 0 to the CBEIF flag in the FSTAT register to abort a command write sequence.

The ACCERR flag will not be set if any Flash register is read during a valid command write sequence.

The ACCERR flag will also be set if any of the following events occur:

1. Launching the sector erase abort command while a sector erase operation is active which results in the early termination of the sector erase operation (see [Section 2.4.1.3.6, “Sector Erase Abort Command”](#))
2. The MCU enters stop mode and a program or erase operation is in progress. The operation is aborted immediately and any pending command is purged (see [Section 2.5.2, “Stop Mode”](#)).

If the Flash memory is read during execution of an algorithm (i.e., CCIF flag in the FSTAT register is low), the read operation will return invalid data and the ACCERR flag will not be set.

If the ACCERR flag is set in any of the banked FSTAT registers, the user must clear the ACCERR flag in all of the banked FSTAT registers before starting another command write sequence (see [Section 2.3.2.7, “Flash Status Register \(FSTAT\)”](#)).

The PVIOL flag will be set after the command is written to the FCMD register during a command write sequence if any of the following illegal operations are attempted, causing the command write sequence to immediately abort:

1. Writing the program command if the address written in the command write sequence was in a protected area of the Flash memory.
2. Writing the sector erase command if the address written in the command write sequence was in a protected area of the Flash memory.

3. Writing the mass erase command while any Flash protection is enabled.

If the PVIOL flag is set in any of the banked FSTAT registers, the user must clear the PVIOL flag in all of the banked FSTAT registers before starting another command write sequence (see [Section 2.3.2.7](#), “Flash Status Register (FSTAT)”).

2.5 Operating Modes

2.5.1 Wait Mode

If a command is active (CCIF = 0) when the MCU enters wait mode, the active command and any buffered command will be completed.

The Flash module can recover the MCU from wait mode if the CBEIF and CCIF interrupts are enabled ([Section 2.8](#), “Interrupts”).

2.5.2 Stop Mode

If a command is active (CCIF = 0) when the MCU enters stop mode, the operation will be aborted and, if the operation is program or erase, the Flash array data being programmed or erased may be corrupted and the CCIF and ACCERR flags will be set. If active, the high voltage circuitry to the Flash memory will immediately be switched off when entering stop mode. Upon exit from stop mode, the CBEIF flag is set and any buffered command will not be launched. The ACCERR flag must be cleared before starting a command write sequence (see [Section 2.4.1.2](#), “Command Write Sequence”).

NOTE

As active commands are immediately aborted when the MCU enters stop mode, it is strongly recommended that the user does not use the STOP instruction during program or erase operations.

2.5.3 Background Debug Mode

In background debug mode (BDM), the FPROT register is writable. If the MCU is unsecured, then all Flash commands listed in [Table 2-21](#) can be executed.

2.6 Flash Module Security

The Flash module provides the necessary security information to the MCU. After each reset, the Flash module determines the security state of the MCU as defined in [Section 2.3.2.2](#), “Flash Security Register (FSEC)”.

The contents of the Flash security byte at 0xFF0F in the Flash configuration field must be changed directly by programming 0xFF0F when the MCU is unsecured and the higher address sector is unprotected. If the Flash security byte remains in a secured state, any reset will cause the MCU to initialize to a secure operating mode.

2.6.1 Unsecuring the MCU using Backdoor Key Access

The MCU may be unsecured by using the backdoor key access feature which requires knowledge of the contents of the backdoor keys (four 16-bit words programmed at addresses 0xFF00–0xFF07). If the KEYEN[1:0] bits are in the enabled state (see [Section 2.3.2.2, “Flash Security Register \(FSEC\)”](#)) and the KEYACC bit is set, a write to a backdoor key address in the Flash memory triggers a comparison between the written data and the backdoor key data stored in the Flash memory. If all four words of data are written to the correct addresses in the correct order and the data matches the backdoor keys stored in the Flash memory, the MCU will be unsecured. The data must be written to the backdoor keys sequentially starting with 0xFF00–0xFF01 and ending with 0xFF06–0xFF07. 0x0000 and 0xFFFF are not permitted as backdoor keys. While the KEYACC bit is set, reads of the Flash memory will return invalid data.

The user code stored in the Flash memory must have a method of receiving the backdoor key from an external stimulus. This external stimulus would typically be through one of the on-chip serial ports.

If the KEYEN[1:0] bits are in the enabled state (see [Section 2.3.2.2, “Flash Security Register \(FSEC\)”](#)), the MCU can be unsecured by the backdoor access sequence described below:

1. Set the KEYACC bit in the Flash configuration register (FCNFG).
2. Write the correct four 16-bit words to Flash addresses 0xFF00–0xFF07 sequentially starting with 0xFF00.
3. Clear the KEYACC bit.
4. If all four 16-bit words match the backdoor keys stored in Flash addresses 0xFF00–0xFF07, the MCU is unsecured and the SEC[1:0] bits in the FSEC register are forced to the unsecure state of 1:0.

The backdoor key access sequence is monitored by an internal security state machine. An illegal operation during the backdoor key access sequence will cause the security state machine to lock, leaving the MCU in the secured state. A reset of the MCU will cause the security state machine to exit the lock state and allow a new backdoor key access sequence to be attempted. The following operations during the backdoor key access sequence will lock the security state machine:

1. If any of the four 16-bit words does not match the backdoor keys programmed in the Flash array.
2. If the four 16-bit words are written in the wrong sequence.
3. If more than four 16-bit words are written.
4. If any of the four 16-bit words written are 0x0000 or 0xFFFF.
5. If the KEYACC bit does not remain set while the four 16-bit words are written.
6. If any two of the four 16-bit words are written on successive MCU clock cycles.

After the backdoor keys have been correctly matched, the MCU will be unsecured. After the MCU is unsecured, the Flash security byte can be programmed to the unsecure state, if desired.

In the unsecure state, the user has full control of the contents of the backdoor keys by programming addresses 0xFF00–0xFF07 in the Flash configuration field.

The security as defined in the Flash security byte (0xFF0F) is not changed by using the backdoor key access sequence to unsecure. The backdoor keys stored in addresses 0xFF00–0xFF07 are unaffected by the backdoor key access sequence. After the next reset of the MCU, the security state of the Flash module

is determined by the Flash security byte (0xFF0F). The backdoor key access sequence has no effect on the program and erase protections defined in the Flash protection register.

It is not possible to unsecure the MCU in special single-chip mode by using the backdoor key access sequence via the background debug mode (BDM).

2.6.2 Unsecuring the Flash Module in Special Single-Chip Mode using BDM

The MCU can be unsecured in special single-chip mode by erasing the Flash module by the following method :

- Reset the MCU into special single-chip mode, delay while the erase test is performed by the BDM secure ROM, send BDM commands to disable protection in the Flash module, and execute a mass erase command write sequence to erase the Flash memory.

After the CCIF flag sets to indicate that the mass operation has completed, reset the MCU into special single-chip mode. The BDM secure ROM will verify that the Flash memory is erased and will assert the UNSEC bit in the BDM status register. This BDM action will cause the MCU to override the Flash security state and the MCU will be unsecured. All BDM commands will be enabled and the Flash security byte may be programmed to the unsecure state by the following method:

- Send BDM commands to execute a word program sequence to program the Flash security byte to the unsecured state and reset the MCU.

2.7 Resets

2.7.1 Flash Reset Sequence

On each reset, the Flash module executes a reset sequence to hold CPU activity while loading the following registers from the Flash memory according to [Table 2-2](#):

- FPROT — Flash Protection Register (see [Section 2.3.2.5](#)).
- FCTL — Flash Control Register (see [Section 2.3.2.9](#)).
- FSEC — Flash Security Register (see [Section 2.3.2.2](#)).

2.7.2 Reset While Flash Command Active

If a reset occurs while any Flash command is in progress, that command will be immediately aborted. The state of the word being programmed or the sector / block being erased is not guaranteed.

2.8 Interrupts

The Flash module can generate an interrupt when all Flash command operations have completed, when the Flash address, data, and command buffers are empty.

Table 2-22. Flash Interrupt Sources

Interrupt Source	Interrupt Flag	Local Enable	Global (CCR) Mask
Flash address, data and command buffers empty	CBEIF (FSTAT register)	CBEIE (FCNFG register)	I Bit
All Flash commands completed	CCIF (FSTAT register)	CCIE (FCNFG register)	I Bit

NOTE

Vector addresses and their relative interrupt priority are determined at the MCU level.

2.8.1 Description of Flash Interrupt Operation

The logic used for generating interrupts is shown in [Figure 2-30](#).

The Flash module uses the CBEIF and CCIF flags in combination with the CBEIE and CCIE enable bits to generate the Flash command interrupt request.

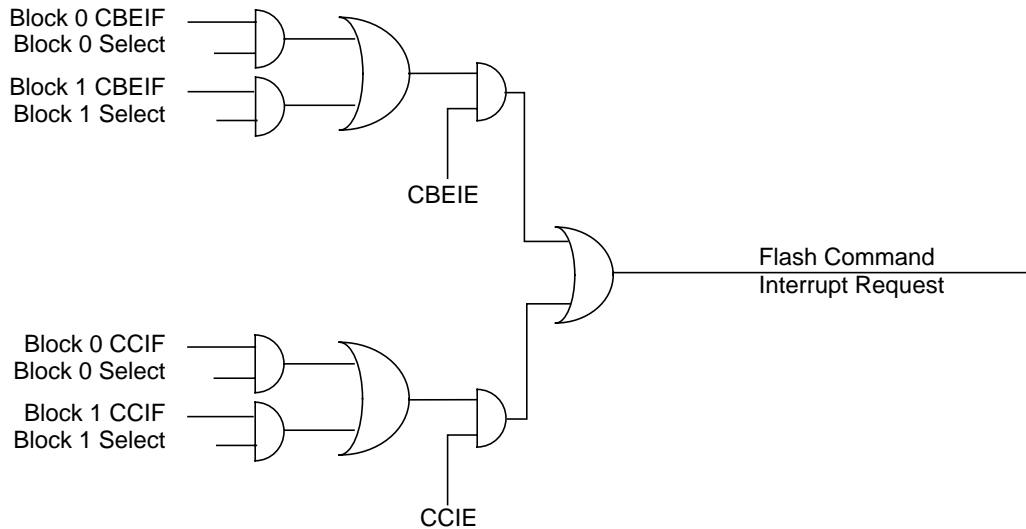
Figure 2-30. Flash Interrupt Implementation

For a detailed description of the register bits, refer to [Section 2.3.2.4, “Flash Configuration Register \(FCNFG\)”](#) and [Section 2.3.2.7, “Flash Status Register \(FSTAT\)”](#).

Chapter 3

Port Integration Module (PIM9E256V1) Block Description

3.1 Introduction

The port integration module establishes the interface between the peripheral modules and the I/O pins for ports AD, M, P, Q, S, T and U.

This section covers:

- Port A, B, E, and K and the BKGD pin
- Port AD associated with ATD module (channels 15 through 0) and keyboard wake-up interrupts
- Port M connected to 2 DAC, 1 IIC and 1 SCI (SCI2) modules
- Port P and port Q connected to PMF module
- Port S connected to 2 SCI (SCI0 and SCI1) and 1 SPI modules
- Port T connected to 2 TIM (TIM0 and TIM1) modules
- Port U connected to 1 TIM (TIM2) and 1 PWM modules

Each I/O pin can be configured by several registers: input/output selection, drive strength reduction, enable and select of pull resistors, wired-or mode selection, interrupt enable, and/or status flags.

NOTE

Refer to the MEBI block description chapter for details on ports A, B, E and K, and the BKGD pin.

3.1.1 Features

A standard port has the following minimum features:

- Input/output selection
- 5-V output drive with two selectable drive strength (or slew rates)
- 5-V digital and analog input
- Input with selectable pull-up or pull-down device

Optional features:

- Open drain for wired-OR connections
- Interrupt input with glitch filtering

3.1.2 Block Diagram

Figure 3-1 is a block diagram of the PIM9E256V1.

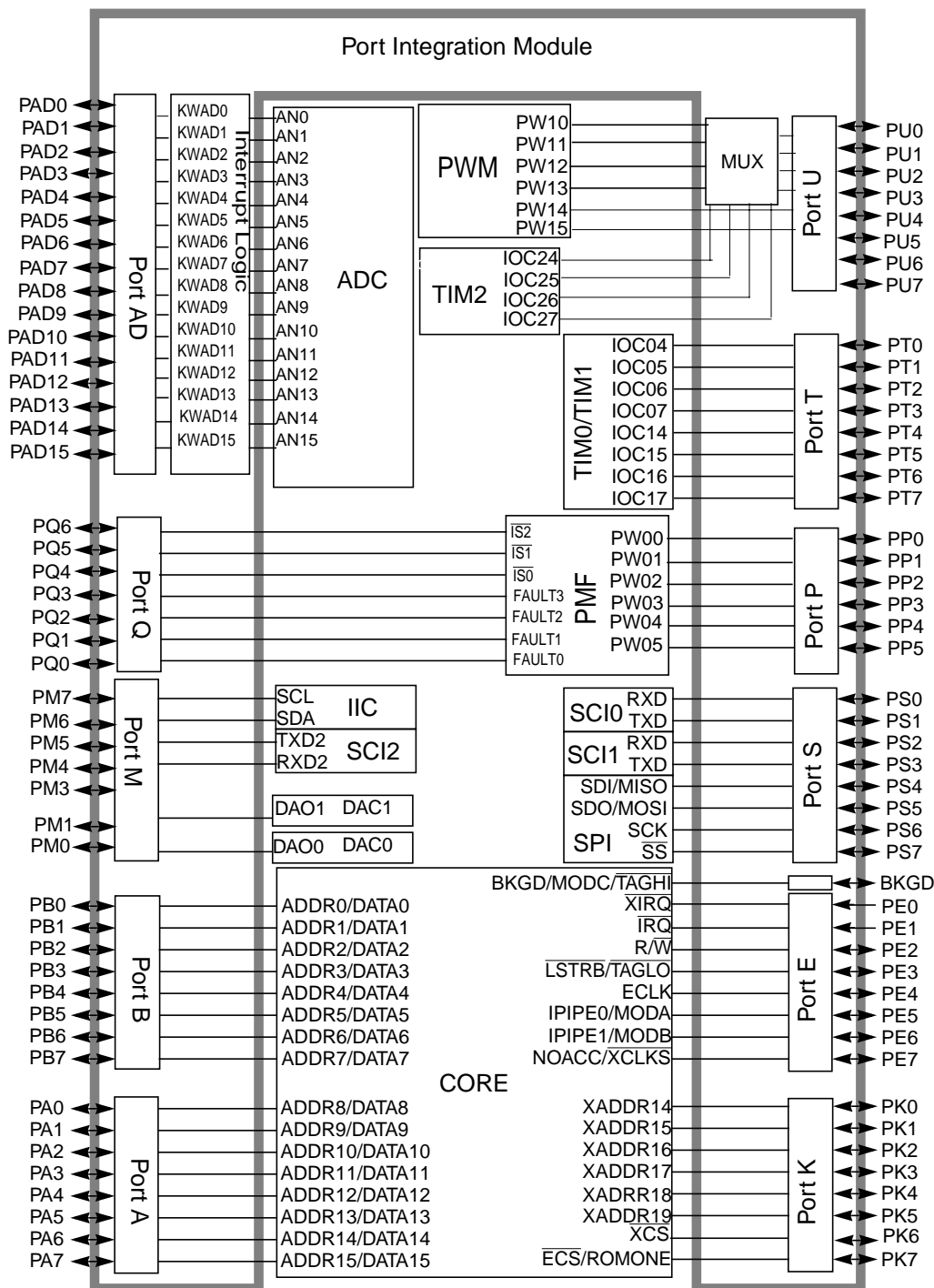

Figure 3-1. PIM9E256V1 Block Diagram

3.2 External Signal Description

This section lists and describes the signals that connect off chip.

Table 3-1 shows all the pins and their functions that are controlled by the PIM9E256V1. The order in which the pin functions are listed represents the functions priority (top – highest priority, bottom – lowest priority).

Table 3-1. Detailed Signal Descriptions (Sheet 1 of 6)

Port	Pin Name	Pin Function	Description	Pin Function after Reset	
—	BKGD	MODC	Refer to the MEBI block description chapter	Refer to the MEBI block description chapter	
		BKGD	Refer to the BDM block description chapter		
		TAGHI	Refer to the MEBI block description chapter		
Port A	PA7	ADDR15/DATA15	Refer to the MEBI block description chapter	Refer to the MEBI block description chapter	
		GPIO	General-purpose I/O		
	PA6	ADDR14/DATA14	Refer to the MEBI block description chapter		
		GPIO	General-purpose I/O		
	PA5	ADDR13/DATA13	Refer to the MEBI block description chapter		
		GPIO	General-purpose I/O		
	PA4	ADDR12/DATA12	Refer to the MEBI block description chapter		
		GPIO	General-purpose I/O		
	PA3	ADDR11/DATA11	Refer to the MEBI block description chapter		
		GPIO	General-purpose I/O		
	PA2	ADDR10/DATA10	Refer to the MEBI block description chapter		
		GPIO	General-purpose I/O		
	PA1	ADDR9/DATA9	Refer to the MEBI block description chapter		
		GPIO	General-purpose I/O		
	PA0	ADDR8/DATA8	Refer to the MEBI block description chapter		
		GPIO	General-purpose I/O		
	Port B	PB7	ADDR7/DATA7	Refer to the MEBI block description chapter	Refer to the MEBI block description chapter
			GPIO	General-purpose I/O	
PB6		ADDR6/DATA6	Refer to the MEBI block description chapter		
		GPIO	General-purpose I/O		
PB5		ADDR5/DATA5	Refer to the MEBI block description chapter		
		GPIO	General-purpose I/O		
PB4		ADDR4/DATA4	Refer to the MEBI block description chapter		
		GPIO	General-purpose I/O		
PB3		ADDR3/DATA3	Refer to the MEBI block description chapter		
		GPIO	General-purpose I/O		
PB2		ADDR2/DATA2	Refer to the MEBI block description chapter		
		GPIO	General-purpose I/O		
PB1		ADDR1/DATA1	Refer to the MEBI block description chapter		
		GPIO	General-purpose I/O		
PB0		ADDR0/DATA0	Refer to the MEBI block description chapter		
		GPIO	General-purpose I/O		

Table 3-1. Detailed Signal Descriptions (Sheet 2 of 6)

Port	Pin Name	Pin Function	Description	Pin Function after Reset
Port E	PE7	XCLKS	Refer to OSC block description chapter	Refer to the MEBI block description chapter
		NOACC	Refer to the MEBI block description chapter	
		GPIO	General-purpose I/O	
	PE6	IPIPE1/MODB	Refer to the MEBI block description chapter	
		GPIO	General-purpose I/O	
	PE5	IPIPE0/MODA	Refer to the MEBI block description chapter	
		GPIO	General-purpose I/O	
	PE4	ECLK	Refer to the MEBI block description chapter	
		GPIO	General-purpose I/O	
	PE3	LSTRB/TAGLO	Refer to the MEBI block description chapter	
		GPIO	General-purpose I/O	
	PE2	R/W	Refer to the MEBI block description chapter	
		GPIO	General-purpose I/O	
	PE1	IRQ	Refer to the MEBI block description chapter	
		GPIO	General-purpose I/O	
	PE0	XIRQ	Refer to the MEBI block description chapter	
		GPIO	General-purpose I/O	
	Port K	PK7	ECS/ROMONE	Refer to the MEBI block description chapter
GPIO			General-purpose I/O	
PK6		XCS	Refer to the MEBI block description chapter	
		GPIO	General-purpose I/O	
PK5		XADDR19	Refer to the MEBI block description chapter	
		GPIO	General-purpose I/O	
PK4		XADDR18	Refer to the MEBI block description chapter	
		GPIO	General-purpose I/O	
PK3		XADDR17	Refer to the MEBI block description chapter	
		GPIO	General-purpose I/O	
PK2		XADDR16	Refer to the MEBI block description chapter	
		GPIO	General-purpose I/O	
PK1		XADDR15	Refer to the MEBI block description chapter	
		GPIO	General-purpose I/O	
PK0		XADDR14	Refer to the MEBI block description chapter	
	GPIO	General-purpose I/O		

Table 3-1. Detailed Signal Descriptions (Sheet 3 of 6)

Port	Pin Name	Pin Function	Description	Pin Function after Reset
Port AD	PAD15	AN15	Analog-to-digital converter input channel 15	GPIO
		KWAD15	Keyboard wake-up interrupt 15	
		GPIO	General-purpose I/O	
	PAD14	AN14	Analog-to-digital converter input channel 14	
		KWAD14	Keyboard wake-up interrupt 14	
		GPIO	General-purpose I/O	
	PAD13	AN13	Analog-to-digital converter input channel 13	
		KWAD13	Keyboard wake-up interrupt 13	
		GPIO	General-purpose I/O	
	PAD12	AN12	Analog-to-digital converter input channel 12	
		KWAD12	Keyboard wake-up interrupt 12	
		GPIO	General-purpose I/O	
	PAD11	AN11	Analog-to-digital converter input channel 11	
		KWAD11	Keyboard wake-up interrupt 11	
		GPIO	General-purpose I/O	
	PAD10	AN10	Analog-to-digital converter input channel 10	
		KWAD10	Keyboard wake-up interrupt 10	
		GPIO	General-purpose I/O	
	PAD9	AN9	Analog-to-digital converter input channel 9	
		KWAD9	Keyboard wake-up interrupt 9	
		GPIO	General-purpose I/O	
	PAD8	AN8	Analog-to-digital converter input channel 8	
		KWAD8	Keyboard wake-up interrupt 8	
		GPIO	General-purpose I/O	
	PAD7	AN7	Analog-to-digital converter input channel 7	
		KWAD7	Keyboard wake-up interrupt 7	
		GPIO	General-purpose I/O	
	PAD6	AN6	Analog-to-digital converter input channel 6	
		KWAD6	Keyboard wake-up interrupt 6	
		GPIO	General-purpose I/O	
	PAD5	AN5	Analog-to-digital converter input channel 5	
		KWAD5	Keyboard wake-up interrupt 5	
		GPIO	General-purpose I/O	
	PAD4	AN4	Analog-to-digital converter input channel 4	
		KWAD4	Keyboard wake-up interrupt 4	
		GPIO	General-purpose I/O	
	PAD3	AN3	Analog-to-digital converter input channel 3	
		KWAD3	Keyboard wake-up interrupt 3	
		GPIO	General-purpose I/O	
	PAD2	AN2	Analog-to-digital converter input channel 2	
		KWAD2	Keyboard wake-up interrupt 2	
		GPIO	General-purpose I/O	
	PAD1	AN1	Analog-to-digital converter input channel 1	
		KWAD1	Keyboard wake-up interrupt 1	
		GPIO	General-purpose I/O	
	PAD0	AN0	Analog-to-digital converter input channel 0	
		KWAD0	Keyboard wake-up interrupt 0	
		GPIO	General-purpose I/O	

Table 3-1. Detailed Signal Descriptions (Sheet 4 of 6)

Port	Pin Name	Pin Function	Description	Pin Function after Reset
Port M	PM7	SCL	Inter-integrated circuit serial clock line	GPIO
		GPIO	General-purpose I/O	
	PM6	SDA	Inter-integrated circuit serial data line	
		GPIO	General-purpose I/O	
	PM5	TXD2	Serial communication interface 2 transmit pin	
		GPIO	General-purpose I/O	
	PM4	RXD2	Serial communication interface 2 receive pin	
		GPIO	General-purpose I/O	
	PM3	GPIO	General-purpose I/O	
	PM1	DAO1	Digital to analog convertor 1 output	
GPIO		General-purpose I/O		
PM0	DAO0	Digital to analog convertor 0 output		
	GPIO	General-purpose I/O		
Port P	PP5	PWM5	Pulse-width modulator 0 channel 5	GPIO
		GPIO	General-purpose I/O	
	PP4	PWM4	Pulse-width modulator 0 channel 4	
		GPIO	General-purpose I/O	
	PP3	PWM3	Pulse-width modulator 0 channel 3	
		GPIO	General-purpose I/O	
	PP2	PWM2	Pulse-width modulator 0 channel 2	
		GPIO	General-purpose I/O	
	PP1	PWM1	Pulse-width modulator 0 channel 1	
		GPIO	General-purpose I/O	
PP0	PWM0	Pulse-width modulator 0 channel 0		
	GPIO	General-purpose I/O		
Port Q	PQ6	IS2	PMF current status pin 2	GPIO
		GPIO	General-purpose I/O	
	PQ5	IS1	PMF current status pin 1	
		GPIO	General-purpose I/O	
	PQ4	IS0	PMF current status pin 0	
		GPIO	General-purpose I/O	
	PQ3	FAULT3	PMF fault pin3	
		GPIO	General-purpose I/O	
	PQ2	FAULT2	PMF fault pin 2	
		GPIO	General-purpose I/O	
PQ1	FAULT11	PMF fault pin 1		
	GPIO	General-purpose I/O		
PQ0	FAULT0	PMF fault pin 0		
	GPIO	General-purpose I/O		

Table 3-1. Detailed Signal Descriptions (Sheet 5 of 6)

Port	Pin Name	Pin Function	Description	Pin Function after Reset		
Port S	PS7	SS	Serial peripheral interface slave select input/output in master mode, input in slave mode	GPIO		
		GPIO	General-purpose I/O			
	PS6	SCK	Serial peripheral interface serial clock pin			
		GPIO	General-purpose I/O			
	PS5	MOSI	Serial peripheral interface master out/slave in pin			
		GPIO	General-purpose I/O			
	PS4	MISO	Serial peripheral interface master in/slave out pin			
		GPIO	General-purpose I/O			
	PS3	TXD0	Serial communication interface 1 transmit pin			
		GPIO	General-purpose I/O			
	PS2	RXD0	Serial communication interface 1 receive pin			
		GPIO	General-purpose I/O			
	PS1	TXD0	Serial communication interface 0 transmit pin			
		GPIO	General-purpose I/O			
	PS0	RXD0	Serial communication interface 0 receive pin			
		GPIO	General-purpose I/O			
	Port T	PT7	IOC7		Timer 1 channel 7	GPIO
			GPIO		General-purpose I/O	
PT6		IOC6	Timer 1 channel 6			
		GPIO	General-purpose I/O			
PT5		IOC5	Timer 1 channel 5			
		GPIO	General-purpose I/O			
PT4		IOC4	Timer 1 channel 4			
		GPIO	General-purpose I/O			
PT3		IOC3	Timer 0 channel 7			
		GPIO	General-purpose I/O			
PT2		IOC2	Timer 0 channel 6			
		GPIO	General-purpose I/O			
PT1		IOC1	Timer 0 channel 5			
		GPIO	General-purpose I/O			
PT0		IOC0	Timer 0 channel 4			
		GPIO	General-purpose I/O			

Table 3-1. Detailed Signal Descriptions (Sheet 6 of 6)

Port	Pin Name	Pin Function	Description	Pin Function after Reset
Port U	PU7	GPIO	General-purpose I/O	GPIO
	PU6	GPIO	General-purpose I/O	
	PU5	PW15	Pulse-width modulator 1 channel 5	
		GPIO	General-purpose I/O	
	PU4	PW14	Pulse-width modulator 1 channel 4	
		GPIO	General-purpose I/O	
	PU3	IOC3	Timer 2 channel 7	
		PW13	Pulse-width modulator 1 channel 3	
		GPIO	General-purpose I/O	
	PU2	IOC2	Timer 2 channel 6	
		PW12	Pulse-width modulator 1 channel 2	
		GPIO	General-purpose I/O	
	PU1	IOC1	Timer 2 channel 5	
		PW11	Pulse-width modulator 1 channel 1	
		GPIO	General-purpose I/O	
PU0	IOC0	Timer 2 channel 4		
	PW11	Pulse-width modulator 1 channel 0		
	GPIO	General-purpose I/O		

3.3 Memory Map and Register Definition

This section provides a detailed description of all registers. [Table 3-2](#) is a standard memory map of port integration module.

Table 3-2. PIM9HZ256 Memory Map

Address Offset	Use	Access
0x0000	Port T I/O Register (PTT)	R/W
0x0001	Port T Input Register (PTIT)	R
0x0002	Port T Data Direction Register (DDRT)	R/W
0x0003	Port T Reduced Drive Register (RDRT)	R/W
0x0004	Port T Pull Device Enable Register (PERT)	R/W
0x0005	Port T Polarity Select Register (PPST)	R/W
0x0006 - 0x0007	Reserved	—
0x0008	Port S I/O Register (PTS)	R/W
0x0009	Port S Input Register (PTIS)	R
0x000A	Port S Data Direction Register (DDRS)	R/W
0x000B	Port S Reduced Drive Register (RDRS)	R/W
0x000C	Port S Pull Device Enable Register (PERS)	R/W
0x000D	Port S Polarity Select Register (PPSS)	R/W
0x000E	Port S Wired-OR Mode Register (WOMS)	R/W
0x000F	Reserved	—
0x0010	Port M I/O Register (PTM)	R/W
0x0011	Port M Input Register (PTIM)	R
0x0012	Port M Data Direction Register (DDRM)	R/W
0x0013	Port M Reduced Drive Register (RDRM)	R/W
0x0014	Port M Pull Device Enable Register (PERM)	R/W
0x0015	Port M Polarity Select Register (PPSM)	R/W
0x0016	Port M Wired-OR Mode Register (WOMM)	R/W
0x0017	Reserved	—
0x0018	Port P I/O Register (PTP)	R/W
0x0019	Port P Input Register (PTIP)	R
0x001A	Port P Data Direction Register (DDRP)	R/W
0x001B	Port P Reduced Drive Register (RDRP)	R/W
0x001C	Port P Pull Device Enable Register (PERP)	R/W
0x001D	Port P Polarity Select Register (PPSP)	R/W
0x001E - 0x001F	Reserved	—

Table 3-2. PIM9HZ256 Memory Map (continued)

Address Offset	Use	Access
0x0020	Port Q I/O Register (PTQ)	R/W
0x0021	Port Q Input Register (PTIQ)	R
0x0022	Port Q Data Direction Register (DDRQ)	R/W
0x0023	Port Q Reduced Drive Register (RDRQ)	R/W
0x0024	Port Q Pull Device Enable Register (PERQ)	R/W
0x0025	Port Q Polarity Select Register (PPSQ)	R/W
0x0026 - 0x0027	Reserved	—
0x0028	Port U I/O Register (PTU)	R/W
0x0029	Port U Input Register (PTIU)	R
0x002A	Port U Data Direction Register (DDRU)	R/W
0x002B	Port U Reduced Drive Register (RDRU)	R/W
0x002C	Port U Pull Device Enable Register (PERU)	R/W
0x002D	Port U Polarity Select Register (PPSU)	R/W
0x002E	Port U Module Routing Register (MODRR)	R/W
0x002F	Reserved	—
0x0030	Port AD I/O Register (PTAD)	R/W
0x0031		
0x0032	Port AD Input Register (PTIAD)	R
0x0033		
0x0034	Port AD Data Direction Register (DDRAD)	R/W
0x0035		
0x0036	Port AD Reduced Drive Register (RDRAD)	R/W
0x0037		
0x0038	Port AD Pull Device Enable Register (PERAD)	R/W
0x0039		
0x003A	Port AD Polarity Select Register (PPSAD)	R/W
0x003B		
0x003D	Port AD Interrupt Enable Register (PIEAD)	R/W
0x003D		
0x003E	Port AD Interrupt Flag Register (PIFAD)	R/W
0x003F		

3.3.1 Port AD

Port AD is associated with the analog-to-digital converter (ATD) and keyboard wake-up (KWU) interrupts. Each pin is assigned to these modules according to the following priority: ATD > KWU > general-purpose I/O.

For the pins of port AD to be used as inputs, the corresponding bits of the ATDDIEN0 and ATDDIEN1 registers in the ATD module must be set to 1 (digital input buffer is enabled). The ATDDIEN0 and ATDDIEN1 registers do not affect the port AD pins when they are configured as outputs.

Refer to the ATD block description chapter for information on the ATDDIEN0 and ATDDIEN1 registers. During reset, port AD pins are configured as high-impedance analog inputs (digital input buffer is disabled).

3.3.1.1 Port AD I/O Register (PTAD)

Module Base + 0x0030

	7	6	5	4	3	2	1	0
R	PTAD15	PTAD14	PTAD13	PTAD12	PTAD11	PTAD10	PTAD9	PTAD8
W	PTAD15	PTAD14	PTAD13	PTAD12	PTAD11	PTAD10	PTAD9	PTAD8
KWU:	KWAD15	KWAD14	KWAD13	KWA12	KWAD11	KWAD10	KWAD9	KWAD8
ATD:	AN15	AN14	AN13	AN12	AN11	AN10	AN9	AN8
Reset	0	0	0	0	0	0	0	0

Module Base + 0x0031

	7	6	5	4	3	2	1	0
R	PTAD7	PTAD6	PTAD5	PTAD4	PTAD3	PTAD2	PTAD1	PTAD0
W	PTAD7	PTAD6	PTAD5	PTAD4	PTAD3	PTAD2	PTAD1	PTAD0
KWU:	KWAD7	KWAD6	KWAD5	KWAD4	KWAD3	KWAD2	KWAD1	KWAD0
ATD:	AN7	AN6	AN5	AN4	AN3	AN2	AN1	AN0
Reset	0	0	0	0	0	0	0	0

Figure 3-2. Port AD I/O Register (PTAD)

Read: Anytime. Write: Anytime.

If the data direction bit of the associated I/O pin (DDRAD_x) is set to 1 (output), a write to the corresponding I/O Register bit sets the value to be driven to the Port AD pin. If the data direction bit of the associated I/O pin (DDRAD_x) is set to 0 (input), a write to the corresponding I/O Register bit takes place but has no effect on the Port AD pin.

If the associated data direction bit (DDRAD_x) is set to 1 (output), a read returns the value of the I/O register bit.

If the associated data direction bit (DDRAD_x) is set to 0 (input) and the associated ATDDIEN0(1) bit is set to 0 (digital input buffer is disabled), the associated I/O register bit (PTAD_x) reads “1”.

If the associated data direction bit (DDRAD_x) is set to 0 (input) and the associated ATDDIEN0(1) bit is set to 1 (digital input buffer is enabled), a read returns the value of the pin.

3.3.1.2 Port AD Input Register (PTIAD)

Module Base + 0x0032

	7	6	5	4	3	2	1	0
R	PTIAD15	PTIAD14	PTIAD13	PTIAD12	PTIAD11	PTIAD10	PTIAD9	PTIAD8
W								
Reset	1	1	1	1	1	1	1	1

Module Base + 0x0033

	7	6	5	4	3	2	1	0
R	PTIAD7	PTIAD6	PTIAD5	PTIAD4	PTIAD3	PTIAD2	PTIAD1	PTIAD0
W								
Reset	1	1	1	1	1	1	1	1

 = Reserved or Unimplemented

Figure 3-3. Port AD Input Register (PTIAD)

Read: Anytime. Write: Never; writes to these registers have no effect.

If the ATDDIEN0(1) bit of the associated I/O pin is set to 0 (digital input buffer is disabled), a read returns a 1. If the ATDDIEN0(1) bit of the associated I/O pin is set to 1 (digital input buffer is enabled), a read returns the status of the associated pin.

3.3.1.3 Port AD Data Direction Register (DDRAD)

Module Base + 0x0034

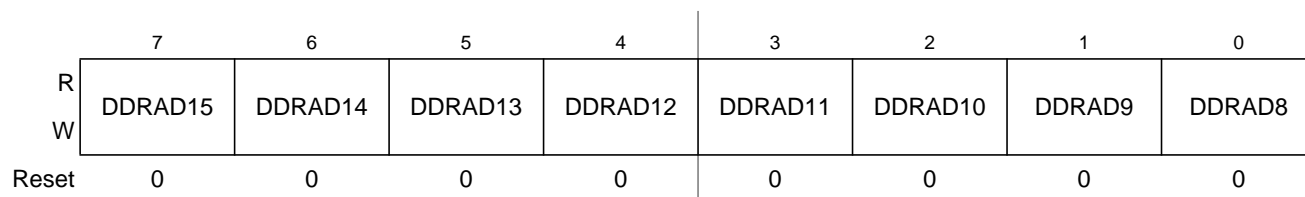

Module Base + 0x0035

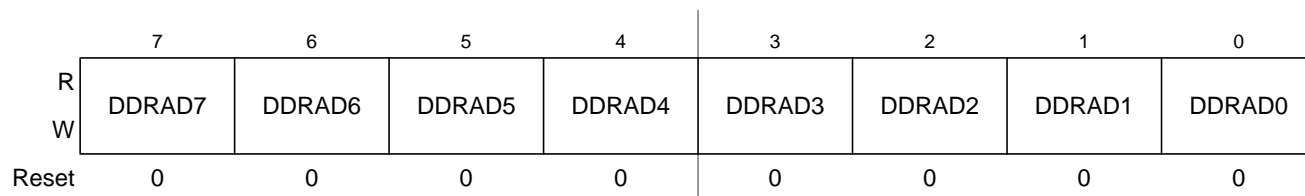

Figure 3-4. Port AD Data Direction Register (DDRAD)

Read: Anytime. Write: Anytime.

This register configures port pins PAD[15:0] as either input or output.

If a data direction bit is 0 (pin configured as input), then a read value on PTADx depends on the associated ATDDIEN0(1) bit. If the associated ATDDIEN0(1) bit is set to 1 (digital input buffer is enabled), a read on PTADx returns the value on port AD pin. If the associated ATDDIEN0(1) bit is set to 0 (digital input buffer is disabled), a read on PTADx returns a 1.

Table 3-3. DDRAD Field Descriptions

Field	Description
15:0 DDRAD[15:0]	Data Direction Port AD 0 Associated pin is configured as input. 1 Associated pin is configured as output.

3.3.1.4 Port AD Reduced Drive Register (RDRAD)

Module Base + 0x0036

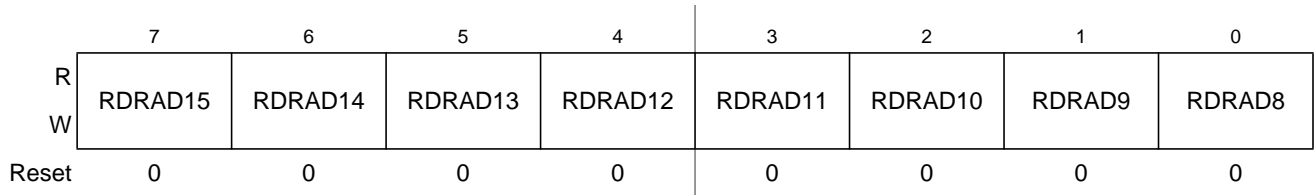

Module Base + 0x0037

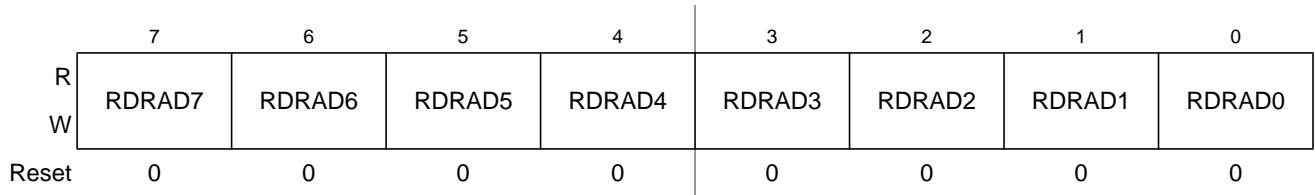

Figure 3-5. Port AD Reduced Drive Register (RDRAD)

Read: Anytime. Write: Anytime.

This register configures the drive strength of configured output pins as either full or reduced. If a pin is configured as input, the corresponding Reduced Drive Register bit has no effect.

Table 3-4. RDRAD Field Descriptions

Field	Description
15:0 RDRAD[15:0]	<p>Reduced Drive Port AD</p> <p>0 Full drive strength at output.</p> <p>1 Associated pin drives at about 1/3 of the full drive strength.</p>

3.3.1.5 Port AD Pull Device Enable Register (PERAD)

Module Base + 0x0038

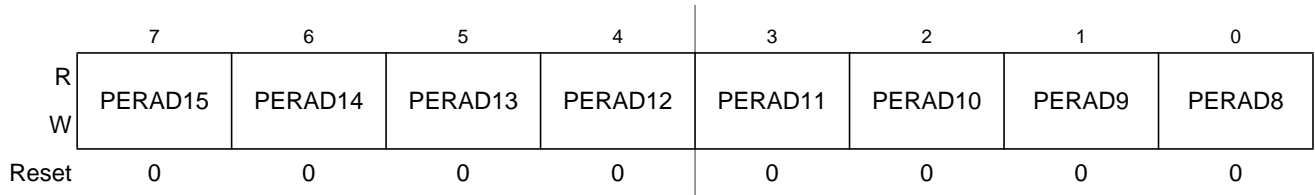

Module Base + 0x0039

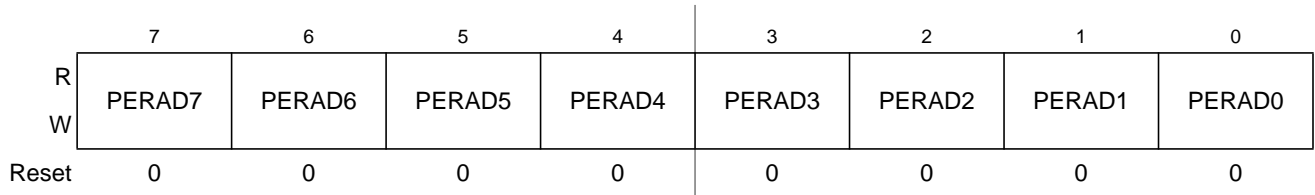

Figure 3-6. Port AD Pull Device Enable Register (PERAD)

Read: Anytime. Write: Anytime.

This register configures whether a pull-up or a pull-down device is activated on configured input pins. If a pin is configured as output, the corresponding Pull Device Enable Register bit has no effect.

Table 3-5. PERAD Field Descriptions

Field	Description
15:0 PERAD[15:0]	Pull Device Enable Port AD 0 Pull-up or pull-down device is disabled. 1 Pull-up or pull-down device is enabled.

3.3.1.6 Port AD Polarity Select Register (PPSAD)

Module Base + 0x003A

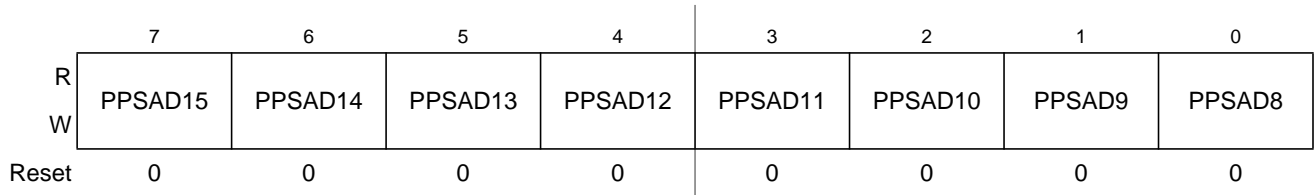

Module Base + 0x003B

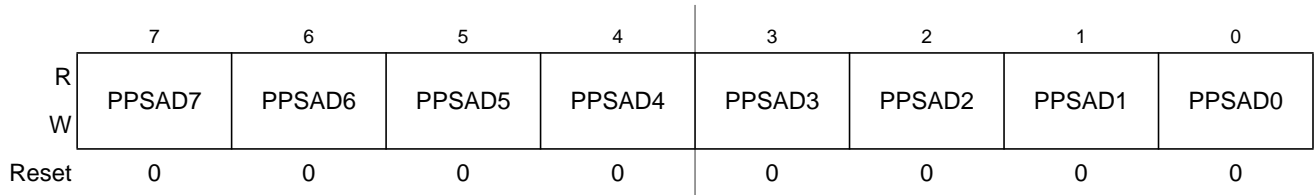

Figure 3-7. Port AD Polarity Select Register (PPSAD)

Read: Anytime. Write: Anytime.

The Port AD Polarity Select Register serves a dual purpose by selecting the polarity of the active interrupt edge as well as selecting a pull-up or pull-down device if enabled (PERADx = 1). The Port AD Polarity Select Register is effective only when the corresponding Data Direction Register bit is set to 0 (input).

In pull-down mode (PPSADx = 1), a rising edge on a port AD pin sets the corresponding PIFADx bit. In pull-up mode (PPSADx = 0), a falling edge on a port AD pin sets the corresponding PIFADx bit.

Table 3-6. PPSAD Field Descriptions

Field	Description
15:0 PPSAD[15:0]	<p>Polarity Select Port AD</p> <p>0 A pull-up device is connected to the associated port AD pin, and detects falling edge for interrupt generation.</p> <p>1 A pull-down device is connected to the associated port AD pin, and detects rising edge for interrupt generation.</p>

3.3.1.7 Port AD Interrupt Enable Register (PIEAD)

Module Base + 0x003C

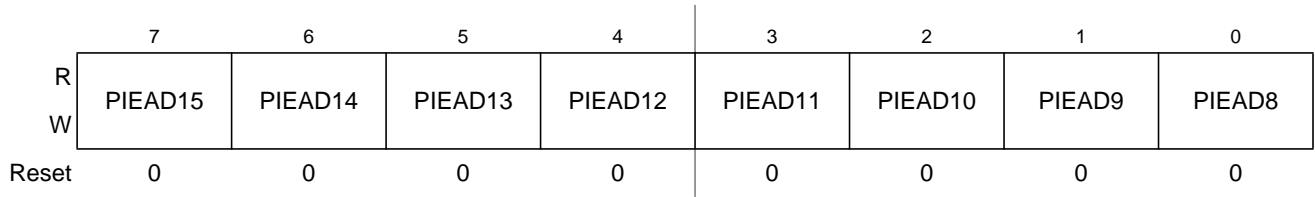

Module Base + 0x003D

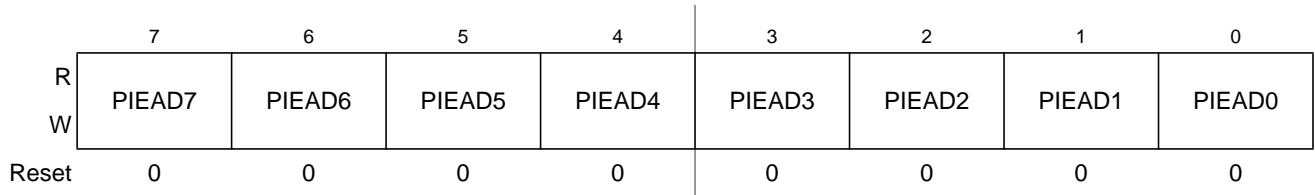

Figure 3-8. Port AD Interrupt Enable Register (PIEAD)

Read: Anytime. Write: Anytime.

This register disables or enables on a per pin basis the edge sensitive external interrupt associated with port AD.

Table 3-7. PIEAD Field Descriptions

Field	Description
15:0 PIEAD[15:0]	<p>Interrupt Enable Port AD</p> <p>0 Interrupt is disabled (interrupt flag masked).</p> <p>1 Interrupt is enabled.</p>

3.3.1.8 Port AD Interrupt Flag Register (PIFAD)

Module Base + 0x003E

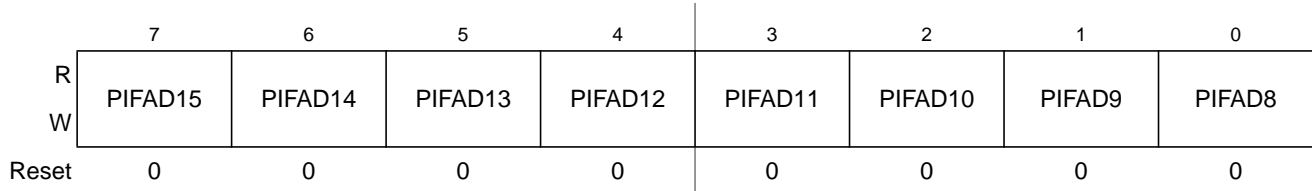

Module Base + 0x003F

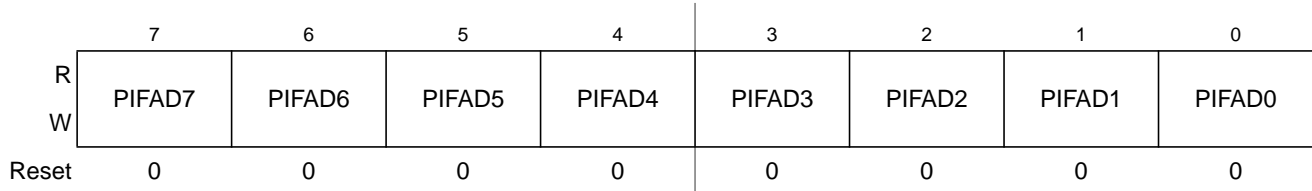

Figure 3-9. Port AD Interrupt Flag Register (PIFAD)

Read: Anytime. Write: Anytime.

Each flag is set by an active edge on the associated input pin. The active edge could be rising or falling based on the state of the corresponding PPSADx bit. To clear each flag, write “1” to the corresponding PIFADx bit. Writing a “0” has no effect.

NOTE

If the ATDDIEN0(1) bit of the associated pin is set to 0 (digital input buffer is disabled), active edges can not be detected.

Table 3-8. PIFAD Field Descriptions

Field	Description
15:0 PIFAD[15:0]	<p>Interrupt Flags Port AD</p> <p>0 No active edge pending. Writing a “0” has no effect.</p> <p>1 Active edge on the associated bit has occurred (an interrupt will occur if the associated enable bit is set). Writing a “1” clears the associated flag.</p>

3.3.2 Port M

Port M is associated with the serial communication interface (SCI2) , Inter-IC bus (IIC) and the digital to analog converter (DAC0 and DAC1) modules. Each pin is assigned to these modules according to the following priority: IIC/SCI2/DAC1/DAC0 > general-purpose I/O.

When the IIC bus is enabled, the PM[7:6] pins become SCL and SDA respectively. Refer to the IIC block description chapter for information on enabling and disabling the IIC bus.

When the SCI2 receiver and transmitter are enabled, the PM[5:4] become RXD2 and TXD2 respectively. Refer to the SCI block description chapter for information on enabling and disabling the SCI receiver and transmitter.

When the DAC1 and DAC0 outputs are enabled, the PM[1:0] become DAO1 and DAO0 respectively. Refer to the DAC block description chapter for information on enabling and disabling the DAC output.

During reset, PM[3] and PM[1:0] pins are configured as high-impedance inputs and PM[7:4] pins are configured as pull-up inputs.

3.3.2.1 Port M I/O Register (PTM)

Module Base + 0x0010

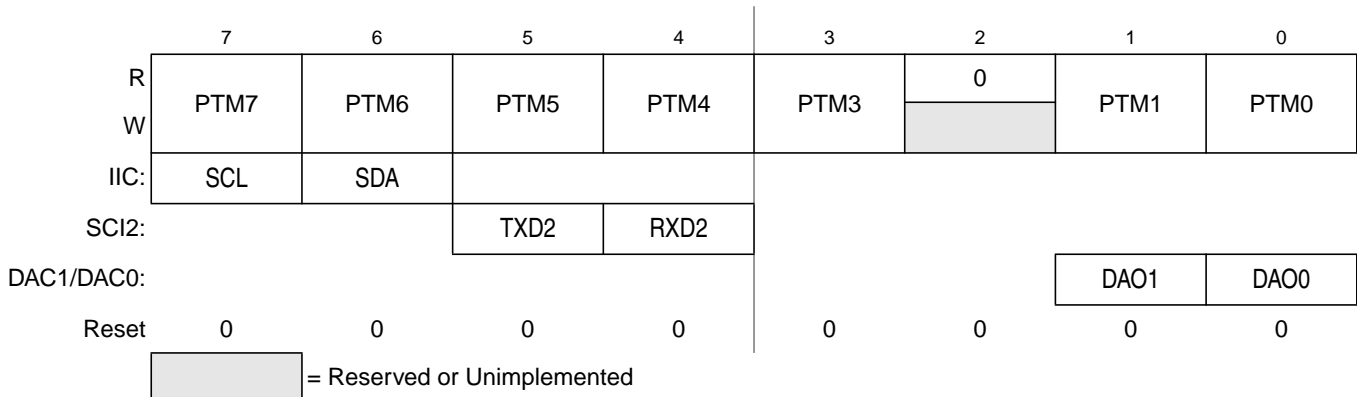

Figure 3-10. Port M I/O Register (PTM)

Read: Anytime. Write: Anytime.

If the associated data direction bit (DDRMx) is set to 1 (output), a read returns the value of the I/O register bit. If the associated data direction bit (DDRMx) is set to 0 (input), a read returns the value of the pin.

3.3.2.2 Port M Input Register (PTIM)

Module Base + 0x0011

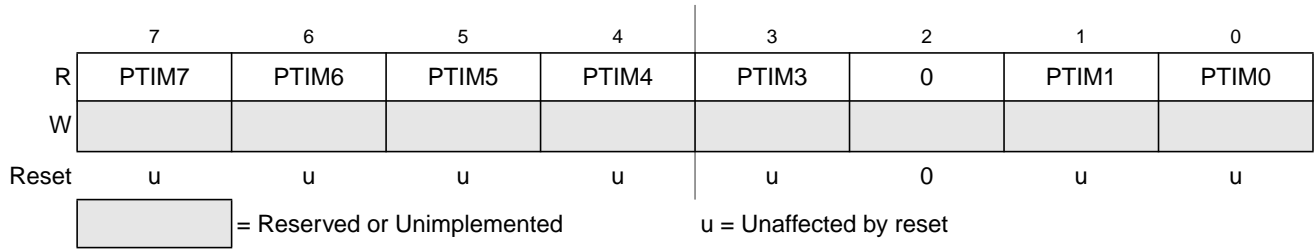

Figure 3-11. Port M Input Register (PTIM)

Read: Anytime. Write: Never, writes to this register have no effect.

This register always reads back the status of the associated pins.

3.3.2.3 Port M Data Direction Register (DDRM)

Module Base + 0x0012

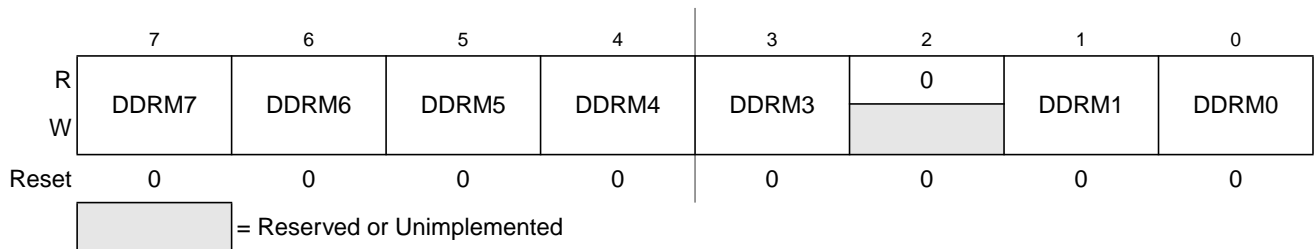

Figure 3-12. Port M Data Direction Register (DDRM)

Read: Anytime. Write: Anytime.

This register configures port pins PM[7:3] and PM[1:0] as either input or output.

If the IIC is enabled, the IIC controls the SCL and SDA I/O direction, and the corresponding DDRM[7:6] bits have no effect on their I/O direction. Refer to the IIC block description chapter for details.

If the SCI2 transmitter is enabled, the I/O direction of the transmit pin TXD2 is controlled by SCI2, and the DDRM5 bit has no effect. If the SCI2 receiver is enabled, the I/O direction of the receive pin RXD2 is controlled by SCI2, and the DDRM4 bit has no effect. Refer to the SCI block description chapter for further details.

If the DAC1 or DAC0 channel is enabled, the associated pin DAO1 or DAO0 is forced to be output, and the associated DDRM1 or DDRM0 bit has no effect.

The DDRM bits do not change to reflect the pin I/O direction when not being used as GPIO. The DDRM[7:3]; DDRM[1:0] bits revert to controlling the I/O direction of the pins when the associated IIC, SCI, or DAC1/0 function are disabled.

Table 3-9. DDRM Field Descriptions

Field	Description
7:3, 1:0 DDRM[7:3, 1:0]	Data Direction Port M 0 Associated pin is configured as input. 1 Associated pin is configured as output.

3.3.2.4 Port M Reduced Drive Register (RDRM)

Module Base + 0x0013

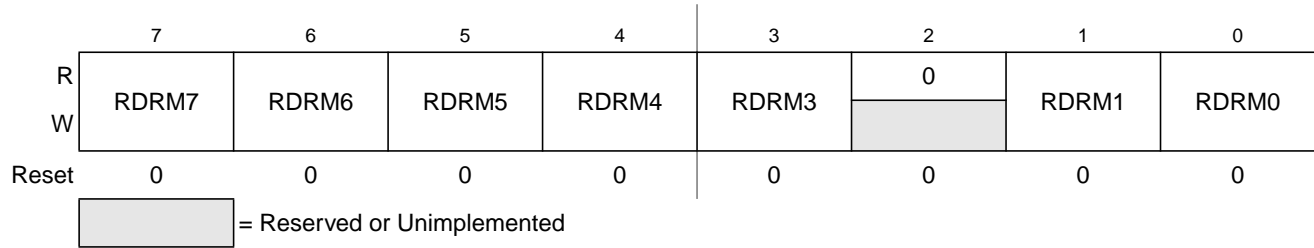
Figure 3-13. Port M Reduced Drive Register (RDRM)

Read: Anytime. Write: Anytime.

This register configures the drive strength of configured output pins as either full or reduced. If a pin is configured as input, the corresponding Reduced Drive Register bit has no effect.

Table 3-10. RDRM Field Descriptions

Field	Description
7:3, 1:0 RDRM[7:3, 1:0]	Reduced Drive Port M 0 Full drive strength at output 1 Associated pin drives at about 1/3 of the full drive strength.

3.3.2.5 Port M Pull Device Enable Register (PERM)

Module Base + 0x0014

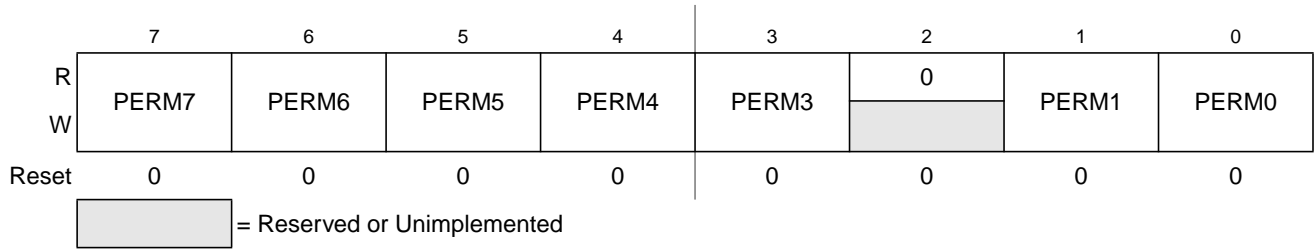

Figure 3-14. Port M Pull Device Enable Register (PERM)

Read: Anytime. Write: Anytime.

This register configures whether a pull-up or a pull-down device is activated on configured input or wired-or output pins. If a pin is configured as push-pull output, the corresponding Pull Device Enable Register bit has no effect.

Table 3-11. PERM Field Descriptions

Field	Description
7:3, 1:0 PERM[7:3, 1:0]	Pull Device Enable Port M 0 Pull-up or pull-down device is disabled. 1 Pull-up or pull-down device is enabled.

3.3.2.6 Port M Polarity Select Register (PPSM)

Module Base + 0x0015

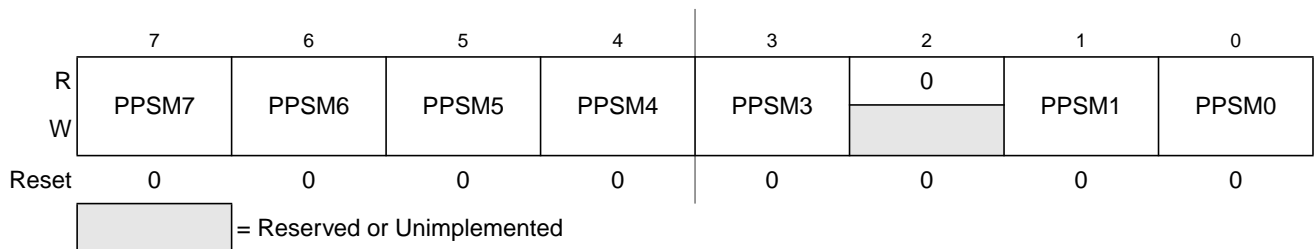

Figure 3-15. Port M Polarity Select Register (PPSM)

Read: Anytime. Write: Anytime.

The Port M Polarity Select Register selects whether a pull-down or a pull-up device is connected to the pin. The Port M Polarity Select Register is effective only when the corresponding Data Direction Register bit is set to 0 (input) and the corresponding Pull Device Enable Register bit is set to 1.

Table 3-12. PPSM Field Descriptions

Field	Description
7:3, 1:0 PPSM[7:3, 1:0]	Pull Select Port M 0 A pull-up device is connected to the associated port M pin. 1 A pull-down device is connected to the associated port M pin.

3.3.2.7 Port M Wired-OR Mode Register (WOMM)

Module Base + 0x0016

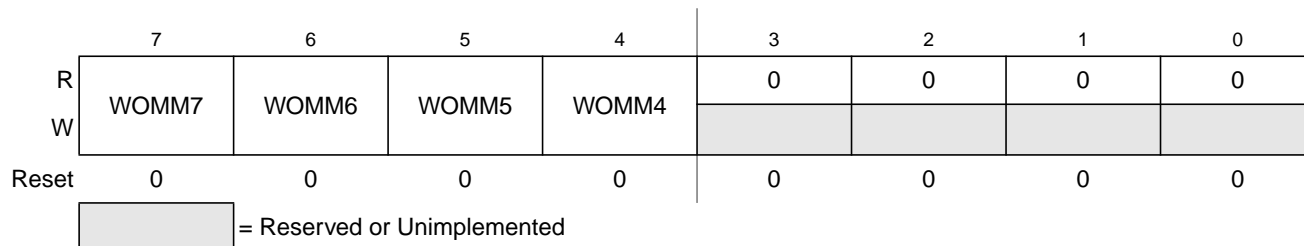
Figure 3-16. Port M Wired-OR Mode Register (WOMM)

Read: Anytime. Write: Anytime.

This register selects whether a port M output is configured as push-pull or wired-or. When a Wired-OR Mode Register bit is set to 1, the corresponding output pin is driven active low only (open drain) and a high level is not driven. A Wired-OR Mode Register bit has no effect if the corresponding pin is configured as an input.

These bits apply also to the SCI2 outputs and allow a multipoint connection of several serial modules.

If the IIC is enabled, the associated pins are always set to wired-or mode, and the state of the WOMM[7:6] bits have no effect. The WOMM[7:6] bits will not change to reflect their wired-or mode configuration when the IIC is enabled.

Table 3-13. WOMM Field Descriptions

Field	Description
7:4 WOMM[7:4]	Wired-OR Mode Port M 0 Output buffers operate as push-pull outputs. 1 Output buffers operate as open-drain outputs.

3.3.3 Port P

Port P is associated with the Pulse Width Modulator (PMF) modules. Each pin is assigned according to the following priority: PMF > general-purpose I/O.

When a PMF channel is enabled, the corresponding pin becomes a PWM output. Refer to the PMF block description chapter for information on enabling and disabling the PWM channels.

During reset, port P pins are configured as high-impedance inputs.

3.3.3.1 Port P I/O Register (PTP)

Module Base + 0x0018

	7	6	5	4	3	2	1	0
R	0	0	PTP5	PTP4	PTP3	PTP2	PTP1	PTP0
W								
PMF:			PW05	PW04	PW03	PW02	PW01	PW00
Reset	0	0	0	0	0	0	0	0

= Reserved or Unimplemented

Figure 3-17. Port P I/O Register (PTP)

Read: Anytime. Write: Anytime.

If the associated data direction bit (DDRPx) is set to 1 (output), a read returns the value of the I/O register bit. If the associated data direction bit (DDRPx) is set to 0 (input), a read returns the value of the pin.

The PMF function takes precedence over the general-purpose I/O function if the associated PWM channel is enabled. The PWM channels 5-0 are outputs if the respective channels are enabled.

3.3.3.2 Port P Input Register (PTIP)

Module Base + 0x0019

	7	6	5	4	3	2	1	0
R	0	0	PTIP5	PTIP4	PTIP3	PTIP2	PTIP1	PTIP0
W								
Reset	0	0	u	u	u	u	u	u

= Reserved or Unimplemented u = Unaffected by reset

Figure 3-18. Port P Input Register (PTIP)

Read: Anytime. Write: Never, writes to this register have no effect.

This register always reads back the status of the associated pins.

3.3.3.3 Port P Data Direction Register (DDRP)

Module Base + 0x001A

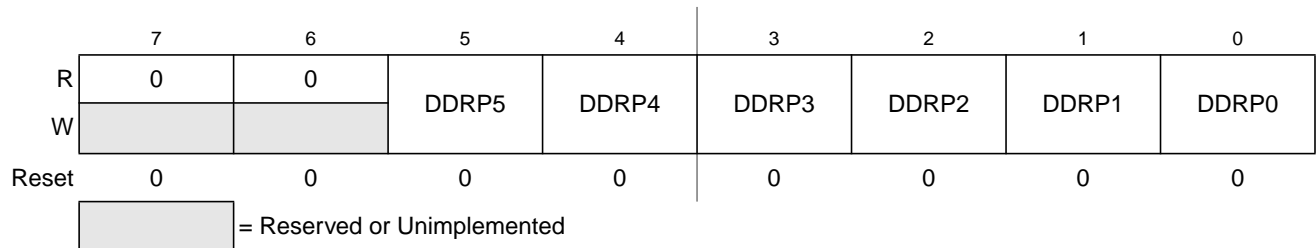

Figure 3-19. Port P Data Direction Register (DDRP)

Read: Anytime. Write: Anytime.

This register configures port pins PP[5:0] as either input or output.

If a PMF channel is enabled, the corresponding pin is forced to be an output and the associated Data Direction Register bit has no effect. If a PMF channel is disabled, the corresponding Data Direction Register bit reverts to control the I/O direction of the associated pin.

Table 3-14. DDRP Field Descriptions

Field	Description
5:0 DDRP[5:0]	Data Direction Port P 0 Associated pin is configured as input. 1 Associated pin is configured as output.

3.3.3.4 Port P Reduced Drive Register (RDRP)

Module Base + 0x001B

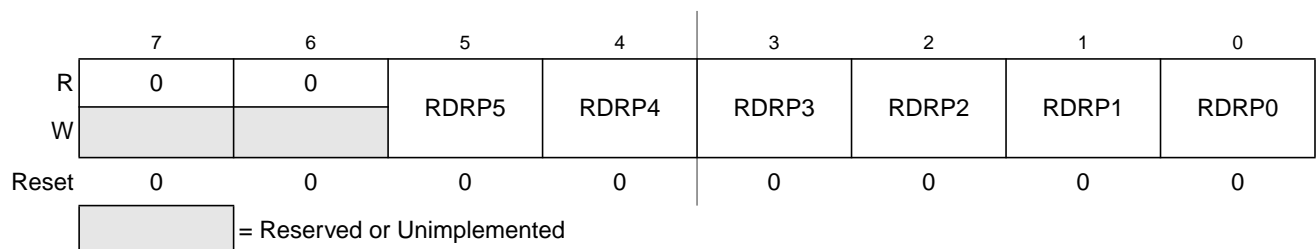

Figure 3-20. Port P Reduced Drive Register (RDRP)

Read: Anytime. Write: Anytime.

This register configures the drive strength of configured output pins as either full or reduced. If a pin is configured as input, the corresponding Reduced Drive Register bit has no effect.

Table 3-15. RDRP Field Descriptions

Field	Description
5:0 RDRP[5:0]	Reduced Drive Port P 0 Full drive strength at output. 1 Associated pin drives at about 1/3 of the full drive strength.

3.3.3.5 Port P Pull Device Enable Register (PERP)

Module Base + 0x001C

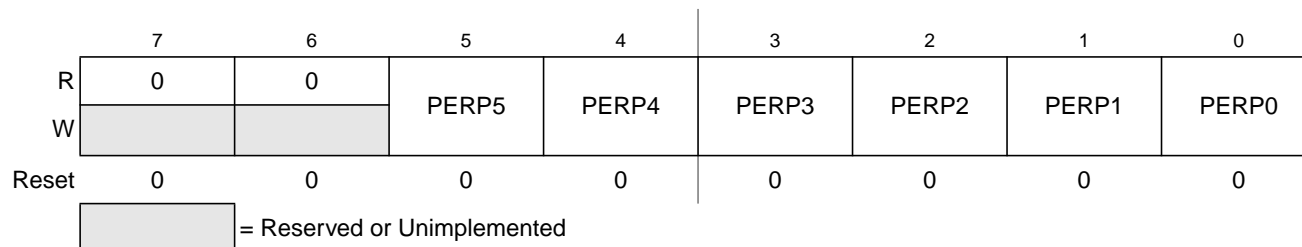

Figure 3-21. Port P Pull Device Enable Register (PERP)

Read: Anytime. Write: Anytime.

This register configures whether a pull-up or a pull-down device is activated on configured input pins. If a pin is configured as output, the corresponding Pull Device Enable Register bit has no effect.

Table 3-16. PERP Field Descriptions

Field	Description
5:0 PERP[5:0]	Pull Device Enable Port P 0 Pull-up or pull-down device is disabled. 1 Pull-up or pull-down device is enabled.

3.3.3.6 Port P Polarity Select Register (PPSP)

Module Base + 0x001D

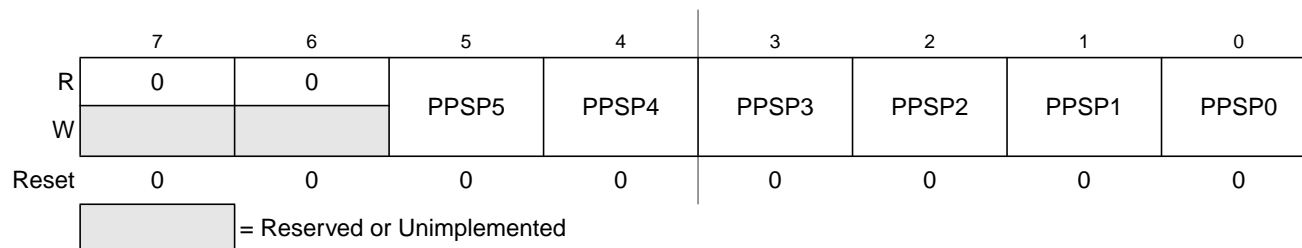

Figure 3-22. Port P Polarity Select Register (PPSP)

Read: Anytime. Write: Anytime.

The Port P Polarity Select Register selects whether a pull-down or a pull-up device is connected to the pin. The Port P Polarity Select Register is effective only when the corresponding Data Direction Register bit is set to 0 (input) and the corresponding Pull Device Enable Register bit is set to 1.

Table 3-17. PPSP Field Descriptions

Field	Description
5:0 PPSP[5:0]	Polarity Select Port P 0 A pull-up device is connected to the associated port P pin. 1 A pull-down device is connected to the associated port P pin.

3.3.4 Port Q

Port Q is associated with the Pulse Width Modulator (PMF) modules. Each pin is assigned according to the following priority: PMF > general-purpose I/O.

When a current status or fault function is enabled, the corresponding pin becomes an input. PQ[3:0] are connected to FAULT[3:0] inputs and PQ[6:4] are connected to \overline{IS} [2:0] inputs of the PMF module. Refer to the PMF block description chapter for information on enabling and disabling these PMF functions.

During reset, port Q pins are configured as high-impedance inputs.

3.3.4.1 Port Q I/O Register (PTQ)

Module Base + 0x0020

	7	6	5	4	3	2	1	0
R	0	PTQ5	PTQ5	PTQ4	PTQ3	PTQ2	PTQ1	PTQ0
W								
PMF:		$\overline{IS2}$	$\overline{IS1}$	$\overline{IS0}$	FAULT3	FAULT2	FAULT1	FAULT0
Reset	0	0	0	0	0	0	0	0

 = Reserved or Unimplemented

Figure 3-23. Port Q I/O Register (PTQ)

Read: Anytime. Write: Anytime.

If the associated data direction bit (DDRQ_x) is set to 1 (output), a read returns the value of the I/O register bit. If the associated data direction bit (DDRQ_x) is set to 0 (input), a read returns the value of the pin.

3.3.4.2 Port Q Input Register (PTIQ)

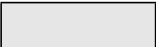
Module Base + 0x0021

	7	6	5	4	3	2	1	0
R	0	PTIQ6	PTIQ5	PTIQ4	PTIQ3	PTIQ2	PTIQ1	PTIQ0
W								
Reset	0	u	u	u	u	u	u	u

 = Reserved or Unimplemented u = Unaffected by reset

Figure 3-24. Port Q Input Register (PTIQ)

Read: Anytime. Write: Never, writes to this register have no effect.

This register always reads back the status of the associated pins.

3.3.4.3 Port Q Data Direction Register (DDRQ)

Module Base + 0x0022

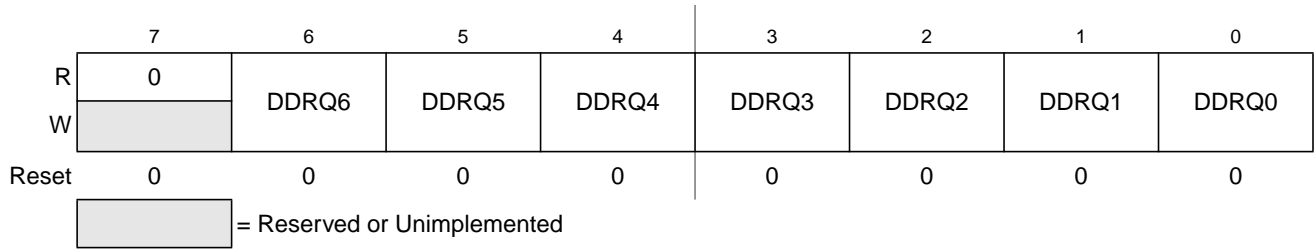

Figure 3-25. Port Q Data Direction Register (DDRQ)

Read: Anytime. Write: Anytime.

This register configures port pins PQ[6:0] as either input or output.

If a PMF function is enabled, the corresponding pin is forced to be an input and the associated Data Direction Register bit has no effect. If a PMF channel is disabled, the corresponding Data Direction Register bit reverts to control the I/O direction of the associated pin.

Table 3-18. DDRQ Field Descriptions

Field	Description
6:0 DDRQ[6:0]	Data Direction Port Q 0 Associated pin is configured as input. 1 Associated pin is configured as output.

3.3.4.4 Port Q Reduced Drive Register (RDRQ)

Module Base + 0x0023

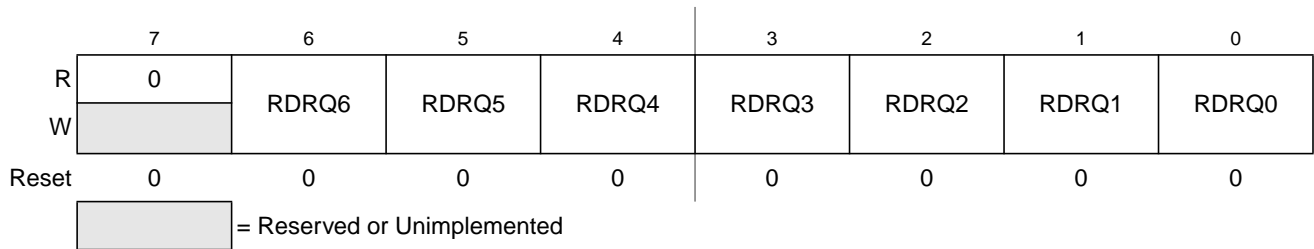

Figure 3-26. Port Q Reduced Drive Register (RDRQ)

Read: Anytime. Write: Anytime.

This register configures the drive strength of configured output pins as either full or reduced. If a pin is configured as input, the corresponding Reduced Drive Register bit has no effect.

Table 3-19. RDRQ Field Descriptions

Field	Description
6:0 RDRQ[6:0]	Reduced Drive Port Q 0 Full drive strength at output. 1 Associated pin drives at about 1/3 of the full drive strength.

3.3.4.5 Port Q Pull Device Enable Register (PERQ)

Module Base + 0x0024

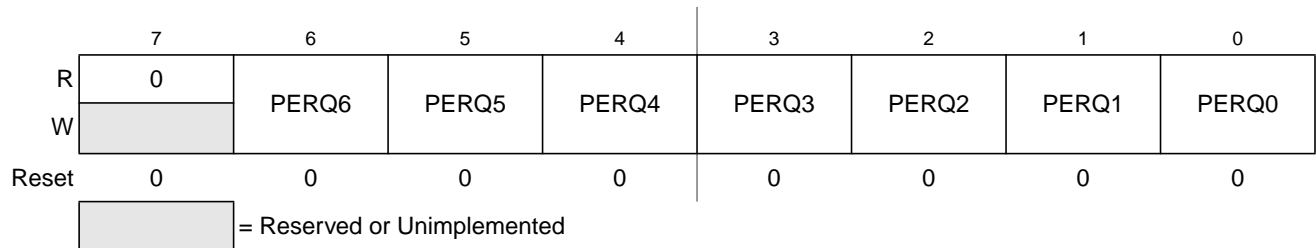
Figure 3-27. Port Q Pull Device Enable Register (PERQ)

Read: Anytime. Write: Anytime.

This register configures whether a pull-up or a pull-down device is activated on configured input pins. If a pin is configured as output, the corresponding Pull Device Enable Register bit has no effect.

Table 3-20. PERP Field Descriptions

Field	Description
6:0 PERQ[6:0]	Pull Device Enable Port P 0 Pull-up or pull-down device is disabled. 1 Pull-up or pull-down device is enabled.

3.3.4.6 Port Q Polarity Select Register (PPSQ)

Module Base + 0x0025

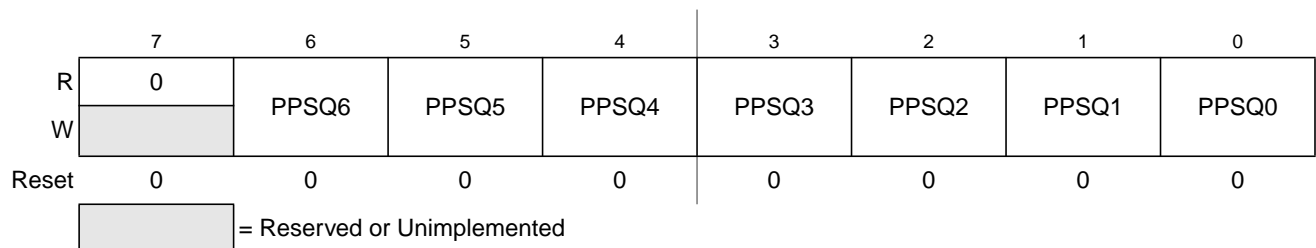
Figure 3-28. Port Q Polarity Select Register (PPSQ)

Read: Anytime. Write: Anytime.

The Port Q Polarity Select Register selects whether a pull-down or a pull-up device is connected to the pin. The Port Q Polarity Select Register is effective only when the corresponding Data Direction Register bit is set to 0 (input) and the corresponding Pull Device Enable Register bit is set to 1.

Table 3-21. PPSP Field Descriptions

Field	Description
6:0 PPSQ[6:0]	Polarity Select Port Q 0 A pull-up device is connected to the associated port Q pin. 1 A pull-down device is connected to the associated port Q pin.

3.3.5 Port S

Port S is associated with the serial peripheral interface (SPI) and serial communication interfaces (SCI0 and SCI1). Each pin is assigned to these modules according to the following priority: SPI/SCI1/SCI0 > general-purpose I/O.

When the SPI is enabled, the PS[7:4] pins become \overline{SS} , SCK, MOSI, and MISO respectively. Refer to the SPI block description chapter for information on enabling and disabling the SPI.

When the SCI1 receiver and transmitter are enabled, the PS[3:2] pins become TXD1 and RXD1 respectively. When the SCI0 receiver and transmitter are enabled, the PS[1:0] pins become TXD0 and RXD0 respectively. Refer to the SCI block description chapter for information on enabling and disabling the SCI receiver and transmitter.

During reset, port S pins are configured as high-impedance inputs.

3.3.5.1 Port S I/O Register (PTS)

Module Base + 0x0008

	7	6	5	4	3	2	1	0
R	PTS7	PTS6	PTS5	PTS4	PTS3	PTS2	PTS1	PTS0
W								
SPI:	\overline{SS}	SCK	MOSI	MISO				
SCI1/SCI0:					TXD1	RXD1	TXD0	RXD0
Reset	0	0	0	0	0	0	0	0

Figure 3-29. Port S I/O Register (PTS)

Read: Anytime. Write: Anytime.

If the associated data direction bit (DDRS_x) is set to 1 (output), a read returns the value of the I/O register bit. If the associated data direction bit (DDRS_x) is set to 0 (input), a read returns the value of the pin.

3.3.5.2 Port S Input Register (PTIS)

Module Base + 0x0009

	7	6	5	4	3	2	1	0
R	PTIS7	PTIS6	PTIS5	PTIS4	PTIS3	PTIS2	PTIS1	PTIS0
W								
Reset	u	u	u	u	u	u	u	u

= Reserved or Unimplemented u = Unaffected by reset

Figure 3-30. Port S Input Register (PTIS)

Read: Anytime. Write: Never, writes to this register have no effect.

This register always reads back the status of the associated pins.

3.3.5.3 Port S Data Direction Register (DDRS)

Module Base + 0x000A

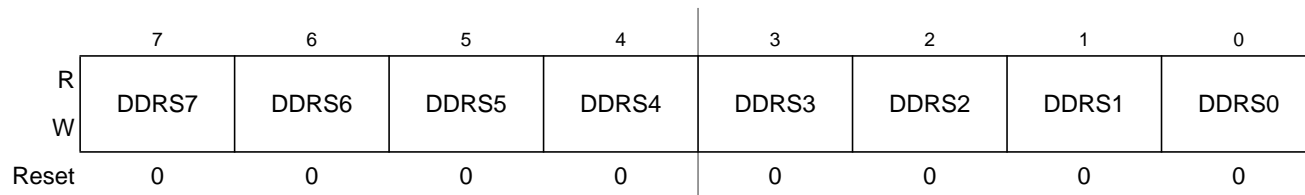

Figure 3-31. Port S Data Direction Register (DDRS)

Read: Anytime. Write: Anytime.

This register configures port pins PS[7:4] and PS[2:0] as either input or output.

When the SPI is enabled, the PS[7:4] pins become the SPI bidirectional pins. The associated Data Direction Register bits have no effect.

When the SCI1 transmitter is enabled, the PS[3] pin becomes the TXD1 output pin and the associated Data Direction Register bit has no effect. When the SCI1 receiver is enabled, the PS[2] pin becomes the RXD1 input pin and the associated Data Direction Register bit has no effect.

When the SCI0 transmitter is enabled, the PS[1] pin becomes the TXD0 output pin and the associated Data Direction Register bit has no effect. When the SCI0 receiver is enabled, the PS[0] pin becomes the RXD0 input pin and the associated Data Direction Register bit has no effect.

If the SPI, SCI1 and SCI0 functions are disabled, the corresponding Data Direction Register bit reverts to control the I/O direction of the associated pin.

Table 3-22. DDRS Field Descriptions

Field	Description
7:0 DDRS[7:0]	Data Direction Port S 0 Associated pin is configured as input. 1 Associated pin is configured as output.

3.3.5.4 Port S Reduced Drive Register (RDRS)

Module Base + 0x000B

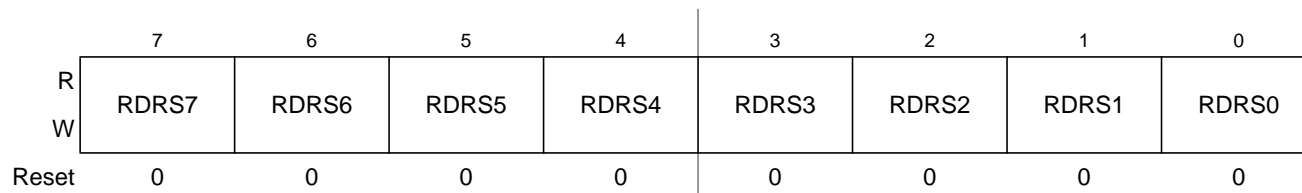

Figure 3-32. Port S Reduced Drive Register (RDRS)

Read: Anytime. Write: Anytime.

This register configures the drive strength of configured output pins as either full or reduced. If a pin is configured as input, the corresponding Reduced Drive Register bit has no effect.

Table 3-23. RDRS Field Descriptions

Field	Description
7:0 RDRS[7:0]	Reduced Drive Port S 0 Full drive strength at output. 1 Associated pin drives at about 1/3 of the full drive strength.

3.3.5.5 Port S Pull Device Enable Register (PERS)

Module Base + 0x000C

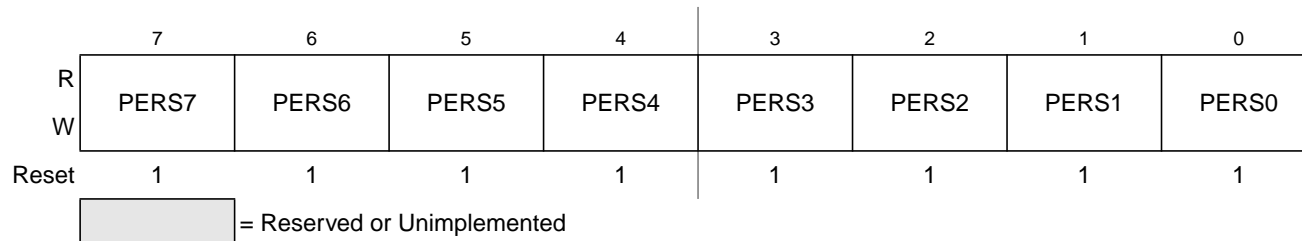

Figure 3-33. Port S Pull Device Enable Register (PERS)

Read: Anytime. Write: Anytime.

This register configures whether a pull-up or a pull-down device is activated on configured input or wired-or (open drain) output pins. If a pin is configured as push-pull output, the corresponding Pull Device Enable Register bit has no effect.

Table 3-24. PERS Field Descriptions

Field	Description
7:0 PERS[7:0]	Pull Device Enable Port S 0 Pull-up or pull-down device is disabled. 1 Pull-up or pull-down device is enabled.

3.3.5.6 Port S Polarity Select Register (PPSS)

Module Base + 0x000D

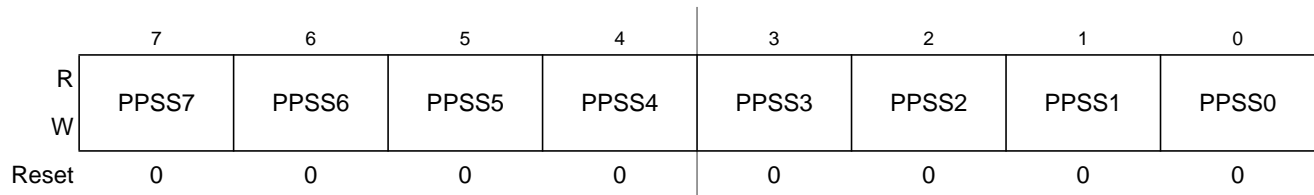
Figure 3-34. Port S Polarity Select Register (PPSS)

Read: Anytime. Write: Anytime.

The Port S Polarity Select Register selects whether a pull-down or a pull-up device is connected to the pin. The Port S Polarity Select Register is effective only when the corresponding Data Direction Register bit is set to 0 (input) and the corresponding Pull Device Enable Register bit is set to 1.

Table 3-25. PPSS Field Descriptions

Field	Description
7:0 PPSS[7:0]	Pull Select Port S 0 A pull-up device is connected to the associated port S pin. 1 A pull-down device is connected to the associated port S pin.

3.3.5.7 Port S Wired-OR Mode Register (WOMS)

Module Base + 0x000E

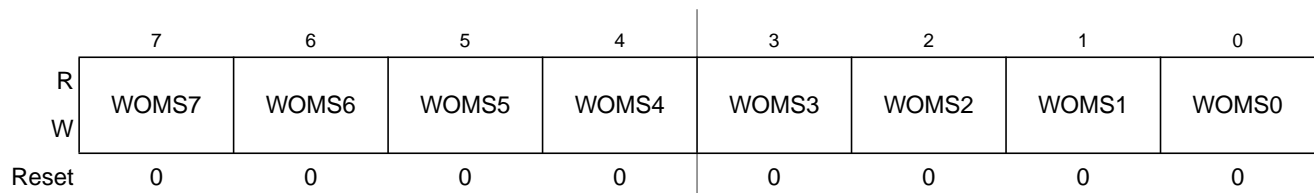
Figure 3-35. Port S Wired-OR Mode Register (WOMS)

Read: Anytime. Write: Anytime.

This register selects whether a port S output is configured as push-pull or wired-or. When a Wired-OR Mode Register bit is set to 1, the corresponding output pin is driven active low only (open drain) and a high level is not driven. A Wired-OR Mode Register bit has no effect if the corresponding pin is configured as an input.

Table 3-26. WOMS Field Descriptions

Field	Description
7:0 WOMS[7:0]	Wired-OR Mode Port S 0 Output buffers operate as push-pull outputs. 1 Output buffers operate as open-drain outputs.

3.3.6 Port T

Port T is associated with two 4-channel timers (TIM0 and TIM1). Each pin is assigned to these modules according to the following priority: TIM1/TIM0 > general-purpose I/O.

If the timer TIM0 is enabled, the channels configured for output compare are available on port T pins PT[3:0]. If the timer TIM1 is enabled, the channels configured for output compare are available on port T pins PT[7:4].

Refer to the TIM block description chapter for information on enabling and disabling the TIM module.

During reset, port T pins are configured as high-impedance inputs.

3.3.6.1 Port T I/O Register (PTT)

Module Base + 0x0000

	7	6	5	4	3	2	1	0
R	PTT7	PTT6	PTT5	PTT4	PTT3	PTT2	PTT1	PTT0
W	PTT7	PTT6	PTT5	PTT4	PTT3	PTT2	PTT1	PTT0
TIM:	OC17	OC16	OC15	OC14	OC07	OC06	OC05	OC04
Reset	0	0	0	0	0	0	0	0

Figure 3-36. Port T I/O Register (PTT)

Read: Anytime. Write: Anytime.

If the associated data direction bit (DDRTx) is set to 1 (output), a read returns the value of the I/O register bit. If the associated data direction bit (DDRTx) is set to 0 (input), a read returns the value of the pin.

3.3.6.2 Port T Input Register (PTIT)

Module Base + 0x0001

	7	6	5	4	3	2	1	0
R	PTIT7	PTIT6	PTIT5	PTIT4	PTIT3	PTIT2	PTIT1	PTIT0
W								
Reset	u	u	u	u	u	u	u	u

= Reserved or Unimplemented u = Unaffected by reset

Figure 3-37. Port T Input Register (PTIT)

Read: Anytime. Write: Never, writes to this register have no effect.

This register always reads back the status of the associated pins.

3.3.6.3 Port T Data Direction Register (DDRT)

Module Base + 0x0002

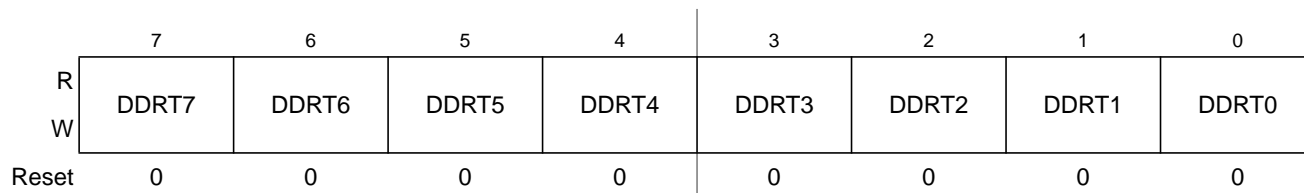

Figure 3-38. Port T Data Direction Register (DDRT)

Read: Anytime. Write: Anytime.

This register configures port pins PT[7:0] as either input or output.

If the TIM0(1) module is enabled, each port pin configured for output compare is forced to be an output and the associated Data Direction Register bit has no effect. If the associated timer output compare is disabled, the corresponding DDRTx bit reverts to control the I/O direction of the associated pin.

If the TIM0(1) module is enabled, each port pin configured as an input capture has the corresponding DDRTx bit controlling the I/O direction of the associated pin.

Table 3-27. DDRT Field Descriptions

Field	Description
7:0 DDRT[7:0]	Data Direction Port T 0 Associated pin is configured as input. 1 Associated pin is configured as output.

3.3.6.4 Port T Reduced Drive Register (RDRT)

Module Base + 0x0003

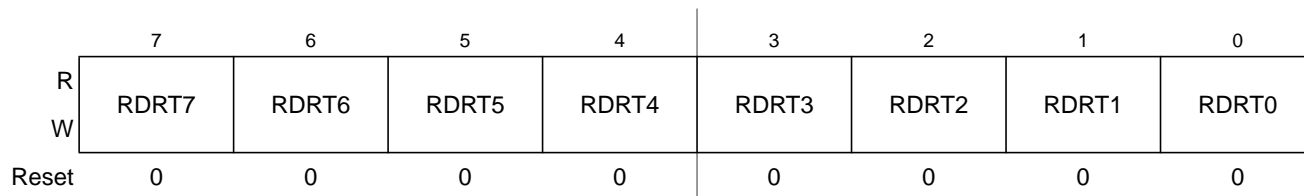

Figure 3-39. Port T Reduced Drive Register (RDRT)

Read: Anytime. Write: Anytime.

This register configures the drive strength of configured output pins as either full or reduced. If a pin is configured as input, the corresponding Reduced Drive Register bit has no effect.

Table 3-28. RDRT Field Descriptions

Field	Description
7:0 RDRT[7:0]	Reduced Drive Port T 0 Full drive strength at output. 1 Associated pin drives at about 1/3 of the full drive strength.

3.3.6.5 Port T Pull Device Enable Register (PERT)

Module Base + 0x0004

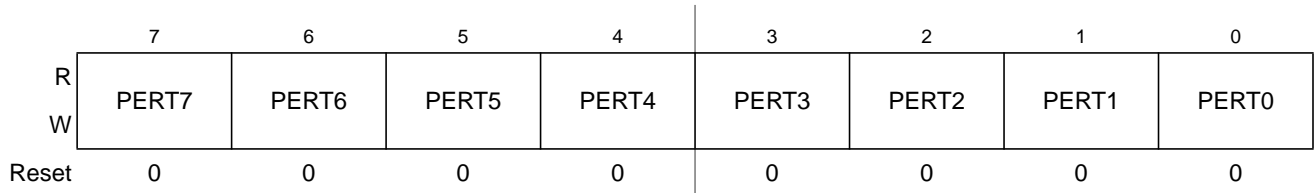

Figure 3-40. Port T Pull Device Enable Register (PERT)

Read: Anytime. Write: Anytime.

This register configures whether a pull-up or a pull-down device is activated on configured input pins. If a pin is configured as output, the corresponding Pull Device Enable Register bit has no effect.

Table 3-29. PERT Field Descriptions

Field	Description
7:0 PERT[7:0]	Pull Device Enable Port T 0 Pull-up or pull-down device is disabled. 1 Pull-up or pull-down device is enabled.

3.3.6.6 Port T Polarity Select Register (PPST)

Module Base + 0x0005

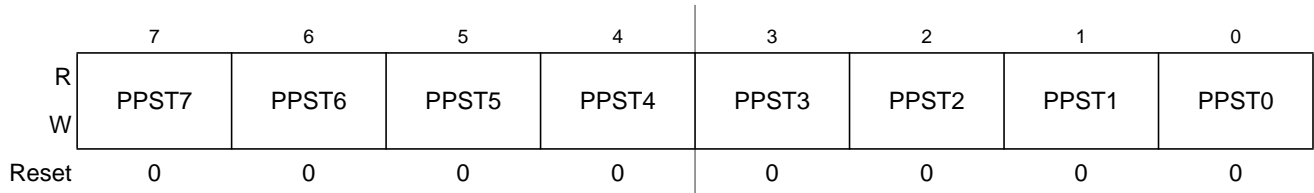

Figure 3-41. Port T Polarity Select Register (PPST)

Read: Anytime. Write: Anytime.

The Port T Polarity Select Register selects whether a pull-down or a pull-up device is connected to the pin. The Port T Polarity Select Register is effective only when the corresponding Data Direction Register bit is set to 0 (input) and the corresponding Pull Device Enable Register bit is set to 1.

Table 3-30. PPST Field Descriptions

Field	Description
7:0 PPST[7:0]	Pull Select Port T 0 A pull-up device is connected to the associated port T pin. 1 A pull-down device is connected to the associated port T pin.

3.3.7 Port U

Port U is associated with one 4-channel timer (TIM2) and the pulse width modulator (PWM) module. Each pin is assigned to these modules according to the following priority: TIM2/PWM > general-purpose I/O.

If the timer TIM2 is enabled, the channels configured for output compare are available on port U pins PU[3:0]. Refer to the TIM block description chapter for information on enabling and disabling the TIM module.

When a PWM channel is enabled, the corresponding pin becomes a PWM output. Refer to the PWM block description chapter for information on enabling and disabling the PWM channels.

If both PWM and TIM2 are enabled simultaneously, the pin functionality is determined by the configuration of the MODRR bits

During reset, port U pins are configured as high-impedance inputs.

3.3.7.1 Port U I/O Register (PTU)

Module Base + 0x0028

	7	6	5	4	3	2	1	0
R	PTU7	PTU6	PTU5	PTU4	PTU3	PTU2	PTU1	PTU0
W								
PWM:			PW15	PW14	PW13	PW12	PW11	PW10
TIM2:					OC27	OC26	OC25	OC24
Reset	0	0	0	0	0	0	0	0

Figure 3-42. Port U I/O Register (PTU)

Read: Anytime. Write: Anytime.

If the associated data direction bit (DDRUx) is set to 1 (output), a read returns the value of the I/O register bit. If the associated data direction bit (DDRUx) is set to 0 (input), a read returns the value of the pin.

3.3.7.2 Port U Input Register (PTIU)

Module Base + 0x0029

	7	6	5	4	3	2	1	0
R	PTIU7	PTIU6	PTIU5	PTIU4	PTIU3	PTIU2	PTIU1	PTIU0
W								
Reset	u	u	u	u	u	u	u	u

= Reserved or Unimplemented u = Unaffected by reset

Figure 3-43. Port U Input Register (PTIU)

Read: Anytime. Write: Never, writes to this register have no effect.

This register always reads back the status of the associated pins.

3.3.7.3 Port U Data Direction Register (DDRU)

Module Base + 0x002A

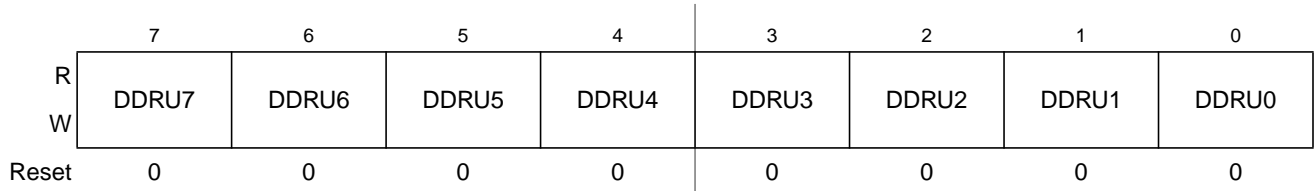

Figure 3-44. Port U Data Direction Register (DDRU)

Read: Anytime. Write: Anytime.

This register configures port pins PU[7:0] as either input or output.

If a pulse width modulator channel is enabled, the associated pin is forced to be an output and the associated Data Direction Register bit has no effect. If the associated pulse width modulator channel is disabled, the corresponding DDRUx bit reverts to control the I/O direction of the associated pin.

If the TIM2 module is enabled, each port pin configured for output compare is forced to be an output and the associated Data Direction Register bit has no effect. If the associated timer output compare is disabled, the corresponding DDRUx bit reverts to control the I/O direction of the associated pin.

If the TIM2 module is enabled, each port pin configured as an input capture has the corresponding DDRUx bit controlling the I/O direction of the associated pin.

When both a timer function and a PWM function are enabled on the same pin, the MODRR register determines which function has control of the pin

Table 3-31. DDRT Field Descriptions

Field	Description
7:0 DDRU[7:0]	Data Direction Port U 0 Associated pin is configured as input. 1 Associated pin is configured as output.

3.3.7.4 Port U Reduced Drive Register (RDRU)

Module Base + 0x002B

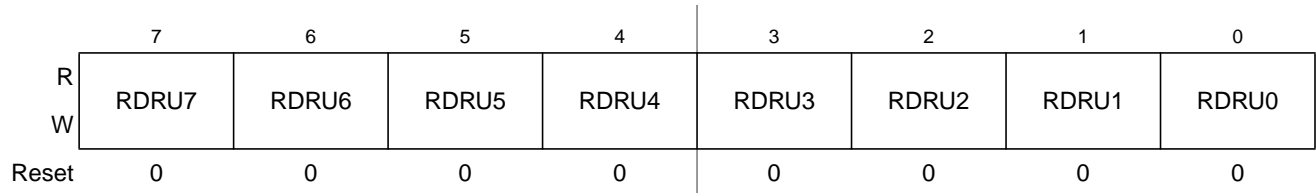
Figure 3-45. Port U Reduced Drive Register (RDRU)

Read: Anytime. Write: Anytime.

This register configures the drive strength of configured output pins as either full or reduced. If a pin is configured as input, the corresponding Reduced Drive Register bit has no effect.

Table 3-32. RDRT Field Descriptions

Field	Description
7:0 RDRU[7:0]	Reduced Drive Port U 0 Full drive strength at output. 1 Associated pin drives at about 1/3 of the full drive strength.

3.3.7.5 Port U Pull Device Enable Register (PERU)

Module Base + 0x002C

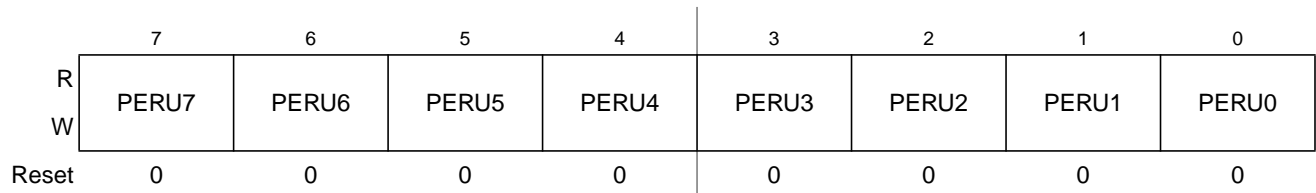
Figure 3-46. Port T Pull Device Enable Register (PERT)

Read: Anytime. Write: Anytime.

This register configures whether a pull-up or a pull-down device is activated on configured input pins. If a pin is configured as output, the corresponding Pull Device Enable Register bit has no effect.

Table 3-33. PERT Field Descriptions

Field	Description
7:0 PERU[7:0]	Pull Device Enable Port U 0 Pull-up or pull-down device is disabled. 1 Pull-up or pull-down device is enabled.

3.3.7.6 Port U Polarity Select Register (PPSU)

Module Base + 0x002D

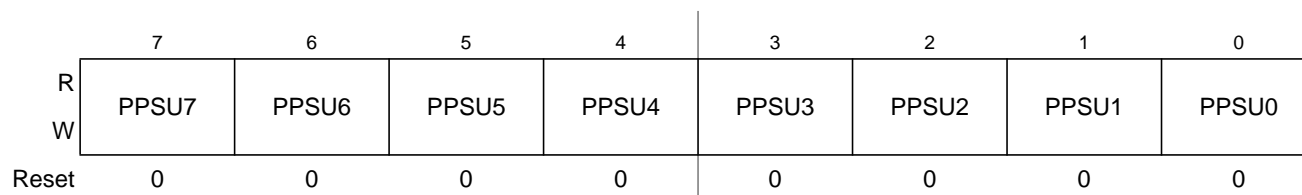

Figure 3-47. Port U Polarity Select Register (PPSU)

Read: Anytime. Write: Anytime.

The Port U Polarity Select Register selects whether a pull-down or a pull-up device is connected to the pin. The Port U Polarity Select Register is effective only when the corresponding Data Direction Register bit is set to 0 (input) and the corresponding Pull Device Enable Register bit is set to 1.

Table 3-34. PPST Field Descriptions

Field	Description
7:0 PPSU[7:0]	Pull Select Port U 0 A pull-up device is connected to the associated port T pin. 1 A pull-down device is connected to the associated port T pin.

3.3.7.7 Port U Module Routing Register (MODRR)

Module Base + 0x002E

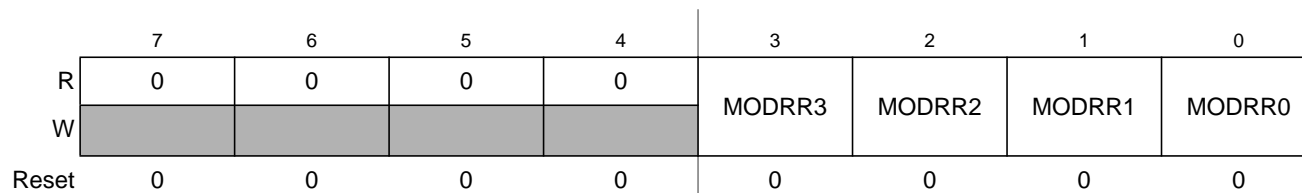

Figure 3-48. Port U Module Routing Register (MODRR)

Read: Anytime. Write: Anytime.

This register selects the module connected to port U.

Table 3-35. MODRR Field Descriptions

Field	Description
3:0 MODRR[3:0]	Pull Select Port U 0 If enabled, TIM2 channel is connected to the associated port U pin. 1 If enabled, PWM channel is connected to the associated port U pin.

3.4 Functional Description

Each pin associated with ports AD, M, P, Q, S, T and U can act as general-purpose I/O. In addition the pin can act as an output from a peripheral module or an input to a peripheral module.

A set of configuration registers is common to all ports. All registers can be written at any time, however a specific configuration might not become active.

Example: Selecting a pull-up resistor. This resistor does not become active while the port is used as a push-pull output.

3.4.1 I/O Register

The I/O Register holds the value driven out to the pin if the port is used as a general-purpose I/O. Writing to the I/O Register only has an effect on the pin if the port is used as general-purpose output.

When reading the I/O Register, the value of each pin is returned if the corresponding Data Direction Register bit is set to 0 (pin configured as input). If the data direction register bits is set to 1, the content of the I/O Register bit is returned. This is independent of any other configuration (Figure 3-49).

Due to internal synchronization circuits, it can take up to 2 bus cycles until the correct value is read on the I/O Register when changing the data direction register.

3.4.2 Input Register

The Input Register is a read-only register and generally returns the value of the pin (Figure 3-49). It can be used to detect overload or short circuit conditions.

Due to internal synchronization circuits, it can take up to 2 bus cycles until the correct value is read on the Input Register when changing the Data Direction Register.

3.4.3 Data Direction Register

The Data Direction Register defines whether the pin is used as an input or an output. A Data Direction Register bit set to 0 configures the pin as an input. A Data Direction Register bit set to 1 configures the pin as an output. If a peripheral module controls the pin the contents of the data direction register is ignored (Figure 3-49).

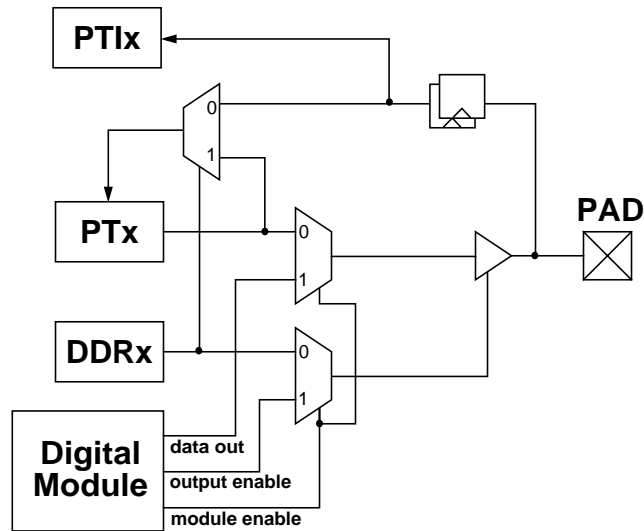

Figure 3-49. Illustration of I/O Pin Functionality

Figure 3-50 shows the state of digital inputs and outputs when an analog module drives the port. When the analog module is enabled all associated digital output ports are disabled and all associated digital input ports read “1”.

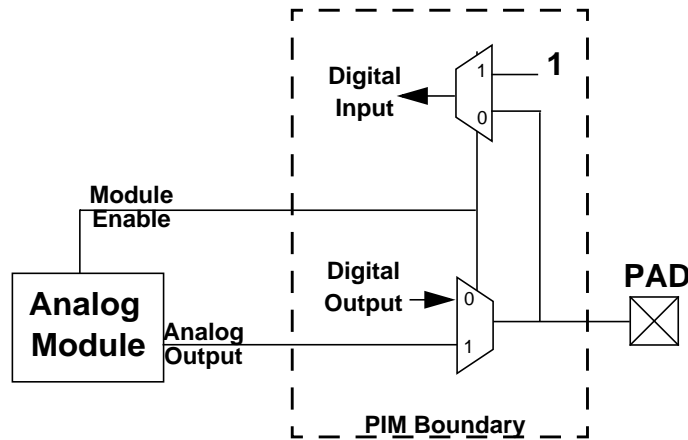

Figure 3-50. Digital Ports and Analog Module

3.4.4 Reduced Drive Register

If the port is used as an output the Reduced Drive Register allows the configuration of the drive strength.

3.4.5 Pull Device Enable Register

The Pull Device Enable Register turns on a pull-up or pull-down device. The pull device becomes active only if the pin is used as an input or as a wired-or output.

3.4.6 Polarity Select Register

The Polarity Select Register selects either a pull-up or pull-down device if enabled. The pull device becomes active only if the pin is used as an input or as a wired-or output.

3.4.7 Pin Configuration Summary

The following table summarizes the effect of various configuration in the Data Direction (DDR), Input/Output (I/O), reduced drive (RDR), Pull Enable (PE), Pull Select (PS) and Interrupt Enable (IE) register bits. The PS configuration bit is used for two purposes:

1. Configure the sensitive interrupt edge (rising or falling), if interrupt is enabled.
2. Select either a pull-up or pull-down device if PE is set to “1”.

Table 3-36. Pin Configuration Summary

DDR	IO	RDR	PE	PS	IE ¹	Function ²	Pull Device	Interrupt
0	X	X	0	X	0	Input	Disabled	Disabled
0	X	X	1	0	0	Input	Pull Up	Disabled
0	X	X	1	1	0	Input	Pull Down	Disabled
0	X	X	0	0	1	Input	Disabled	Falling Edge
0	X	X	0	1	1	Input	Disabled	Rising Edge
0	X	X	1	0	1	Input	Pull Up	Falling Edge
0	X	X	1	1	1	Input	Pull Down	Rising Edge
1	0	0	X	X	0	Output to 0, Full Drive	Disabled	Disabled
1	1	0	X	X	0	Output to 1, Full Drive	Disabled	Disabled
1	0	1	X	X	0	Output to 0, Reduced Drive	Disabled	Disabled
1	1	1	X	X	0	Output to 1, Reduced Drive	Disabled	Disabled
1	0	0	X	0	1	Output to 0, Full Drive	Disabled	Falling Edge
1	1	0	X	1	1	Output to 1, Full Drive	Disabled	Rising Edge
1	0	1	X	0	1	Output to 0, Reduced Drive	Disabled	Falling Edge
1	1	1	X	1	1	Output to 1, Reduced Drive	Disabled	Rising Edge

¹ Applicable only on Port AD.

² Digital outputs are disabled and digital input logic is forced to “1” when an analog module associated with the port is enabled.

3.5 Resets

The reset values of all registers are given in the register description in [Section 3.3, “Memory Map and Register Definition”](#).

All ports start up as general-purpose inputs on reset.

3.5.1 Reset Initialization

All registers including the data registers get set/reset asynchronously. [Table 3-37](#) summarizes the port properties after reset initialization.

Table 3-37. Port Reset State Summary

Port	Reset States				
	Data Direction	Pull Mode	Red. Drive	Wired-OR Mode	Interrupt
A	Refer to section Bus Control and Input/Output	Pull Up	Refer to section Bus Control and Input/Output		
B					
E					
K					
BKGD pin					
AD	Input	Hi-z	Disabled	N/A	Disabled
M[7:4]	Input	Pull Up	Disabled	Disabled	N/A
M[3,1:0]	Input	Hi-z	Disabled	Disabled	N/A
P	Input	Hi-z	Disabled	N/A	N/A
Q	Input	Hi-z	Disabled	N/A	N/A
S	Input	Pull Up	Disabled	Disabled	N/A
T	Input	Hi-z	Disabled	N/A	N/A
U	Input	Hi-z	Disabled	N/A	N/A

3.6 Interrupts

3.6.1 General

Port AD generates an edge sensitive interrupt if enabled. It offers sixteen I/O pins with edge triggered interrupt capability in wired-or fashion. The interrupt enable as well as the sensitivity to rising or falling edges can be individually configured on per pin basis. All eight bits/pins share the same interrupt vector. Interrupts can be used with the pins configured as inputs (with the corresponding ATDDIEN1 bit set to 1) or outputs.

An interrupt is generated when a bit in the port interrupt flag register and its corresponding port interrupt enable bit are both set. This external interrupt feature is capable to wake up the CPU when it is in stop or wait mode.

A digital filter on each pin prevents pulses (Figure 3-52) shorter than a specified time from generating an interrupt. The minimum time varies over process conditions, temperature and voltage (Figure 3-51 and Table 3-38).

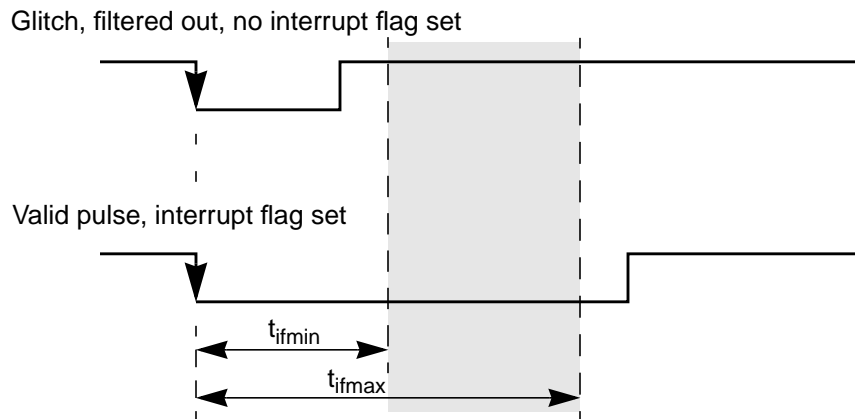

Figure 3-51. Interrupt Glitch Filter on Port AD (PPS = 0)

Table 3-38. Pulse Detection Criteria

Pulse	Mode			
	STOP		STOP ¹	
		Unit		Unit
Ignored	$t_{\text{pulse}} \leq 3$	Bus Clock	$t_{\text{pulse}} \leq 3.2$	∞ s
Uncertain	$3 < t_{\text{pulse}} < 4$	Bus Clock	$3.2 < t_{\text{pulse}} < 10$	∞ s
Valid	$t_{\text{pulse}} \geq 4$	Bus Clock	$t_{\text{pulse}} \geq 10$	∞ s

¹ These values include the spread of the oscillator frequency over temperature, voltage and process.

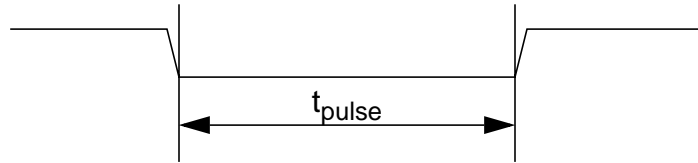

Figure 3-52. Pulse Illustration

A valid edge on an input is detected if 4 consecutive samples of a passive level are followed by 4 consecutive samples of an active level directly or indirectly

The filters are continuously clocked by the bus clock in RUN and WAIT mode. In STOP mode the clock is generated by a single RC oscillator in the port integration module. To maximize current saving the RC oscillator runs only if the following condition is true on any pin:

Sample count ≤ 4 and port interrupt enabled (PIE=1) and port interrupt flag not set (PIF=0).

3.6.2 Interrupt Sources

Table 3-39. Port Integration Module Interrupt Sources

Interrupt Source	Interrupt Flag	Local Enable	Global (CCR) Mask
Port AD	PIFAD[15:0]	PIEAD[15:0]	I Bit

NOTE

Vector addresses and their relative interrupt priority are determined at the MCU level.

3.6.3 Operation in Stop Mode

All clocks are stopped in STOP mode. The port integration module has asynchronous paths on port AD to generate wake-up interrupts from stop mode. For other sources of external interrupts refer to the respective block description chapters.

Chapter 4

Clocks and Reset Generator (CRGV4) Block Description

4.1 Introduction

This specification describes the function of the clocks and reset generator (CRGV4).

4.1.1 Features

The main features of this block are:

- Phase-locked loop (PLL) frequency multiplier
 - Reference divider
 - Automatic bandwidth control mode for low-jitter operation
 - Automatic frequency lock detector
 - CPU interrupt on entry or exit from locked condition
 - Self-clock mode in absence of reference clock
- System clock generator
 - Clock quality check
 - Clock switch for either oscillator- or PLL-based system clocks
 - User selectable disabling of clocks during wait mode for reduced power consumption
- Computer operating properly (COP) watchdog timer with time-out clear window
- System reset generation from the following possible sources:
 - Power-on reset
 - Low voltage reset
 - Refer to the device overview section for availability of this feature.
 - COP reset
 - Loss of clock reset
 - External pin reset
- Real-time interrupt (RTI)

4.1.2 Modes of Operation

This subsection lists and briefly describes all operating modes supported by the CRG.

- **Run mode**

All functional parts of the CRG are running during normal run mode. If RTI or COP functionality is required the individual bits of the associated rate select registers (COPCTL, RTICTL) have to be set to a nonzero value.
- **Wait mode**

This mode allows to disable the system and core clocks depending on the configuration of the individual bits in the CLKSEL register.
- **Stop mode**

Depending on the setting of the PSTP bit, stop mode can be differentiated between full stop mode (PSTP = 0) and pseudo-stop mode (PSTP = 1).

 - **Full stop mode**

The oscillator is disabled and thus all system and core clocks are stopped. The COP and the RTI remain frozen.
 - **Pseudo-stop mode**

The oscillator continues to run and most of the system and core clocks are stopped. If the respective enable bits are set the COP and RTI will continue to run, else they remain frozen.
- **Self-clock mode**

Self-clock mode will be entered if the clock monitor enable bit (CME) and the self-clock mode enable bit (SCME) are both asserted and the clock monitor in the oscillator block detects a loss of clock. As soon as self-clock mode is entered the CRGV4 starts to perform a clock quality check. Self-clock mode remains active until the clock quality check indicates that the required quality of the incoming clock signal is met (frequency and amplitude). Self-clock mode should be used for safety purposes only. It provides reduced functionality to the MCU in case a loss of clock is causing severe system conditions.

4.1.3 Block Diagram

Figure 4-1 shows a block diagram of the CRGV4.

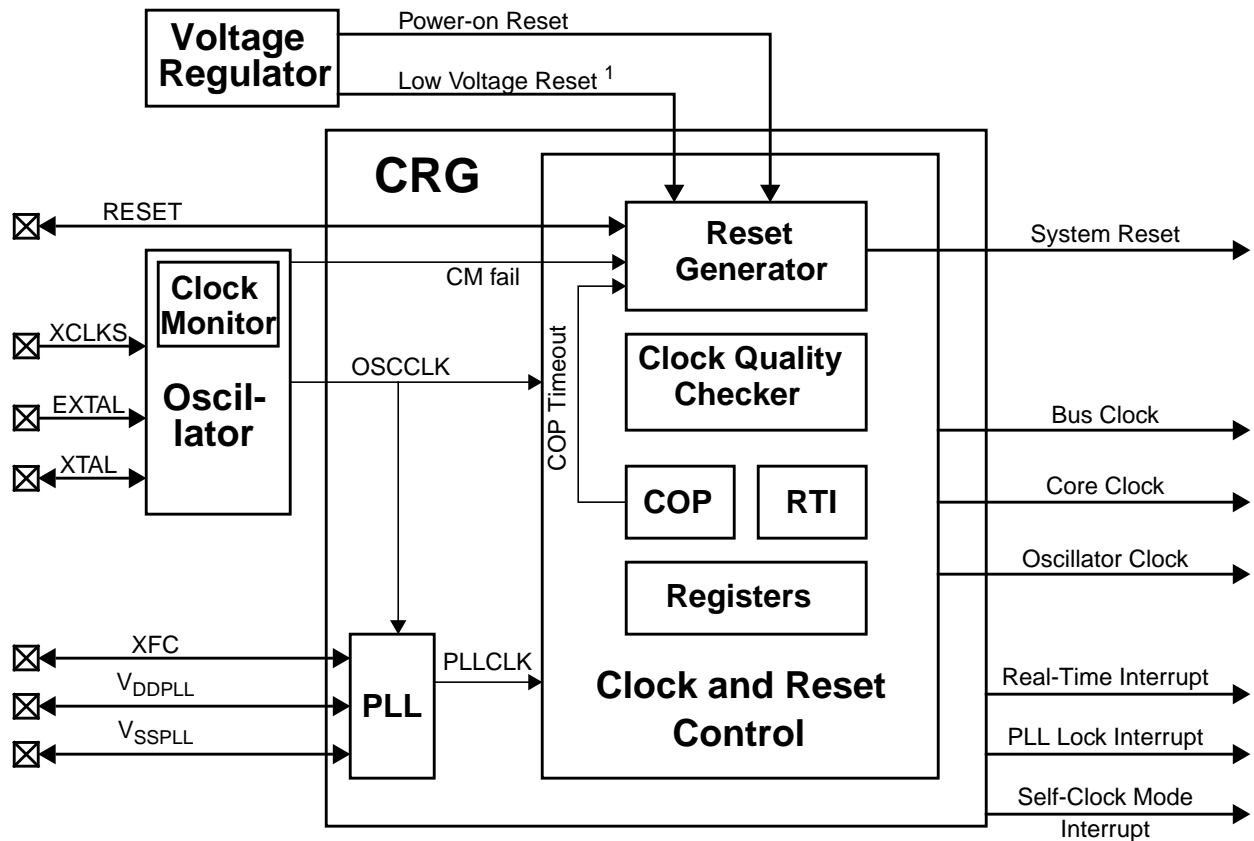

¹ Refer to the device overview section for availability of the low-voltage reset feature.

Figure 4-1. CRG Block Diagram

4.2 External Signal Description

This section lists and describes the signals that connect off chip.

4.2.1 V_{DDPLL} , V_{SSPLL} — PLL Operating Voltage, PLL Ground

These pins provides operating voltage (V_{DDPLL}) and ground (V_{SSPLL}) for the PLL circuitry. This allows the supply voltage to the PLL to be independently bypassed. Even if PLL usage is not required V_{DDPLL} and V_{SSPLL} must be connected properly.

4.2.2 XFC — PLL Loop Filter Pin

A passive external loop filter must be placed on the XFC pin. The filter is a second-order, low-pass filter to eliminate the VCO input ripple. The value of the external filter network and the reference frequency determines the speed of the corrections and the stability of the PLL. Refer to the device overview chapter for calculation of PLL loop filter (XFC) components. If PLL usage is not required the XFC pin must be tied to V_{DDPLL} .

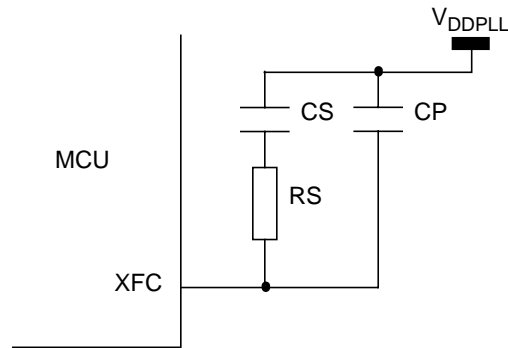

Figure 4-2. PLL Loop Filter Connections

4.2.3 $\overline{\text{RESET}}$ — Reset Pin

$\overline{\text{RESET}}$ is an active low bidirectional reset pin. As an input it initializes the MCU asynchronously to a known start-up state. As an open-drain output it indicates that a system reset (internal to MCU) has been triggered.

4.3 Memory Map and Register Definition

This section provides a detailed description of all registers accessible in the CRGV4.

4.3.1 Module Memory Map

Table 4-1 gives an overview on all CRGV4 registers.

Table 4-1. CRGV4 Memory Map

Address Offset	Use	Access
0x0000	CRG Synthesizer Register (SYNR)	R/W
0x0001	CRG Reference Divider Register (REFDV)	R/W
0x0002	CRG Test Flags Register (CTFLG) ¹	R/W
0x0003	CRG Flags Register (CRGFLG)	R/W
0x0004	CRG Interrupt Enable Register (CRGINT)	R/W
0x0005	CRG Clock Select Register (CLKSEL)	R/W
0x0006	CRG PLL Control Register (PLLCTL)	R/W
0x0007	CRG RTI Control Register (RTICTL)	R/W
0x0008	CRG COP Control Register (COPCTL)	R/W
0x0009	CRG Force and Bypass Test Register (FORBYP) ²	R/W
0x000A	CRG Test Control Register (CTCTL) ³	R/W
0x000B	CRG COP Arm/Timer Reset (ARMCOP)	R/W

¹ CTFLG is intended for factory test purposes only.

² FORBYP is intended for factory test purposes only.

³ CTCTL is intended for factory test purposes only.

NOTE

Register address = base address + address offset, where the base address is defined at the MCU level and the address offset is defined at the module level.

4.3.2 Register Descriptions

This section describes in address order all the CRGV4 registers and their individual bits.

Register Name		Bit 7	6	5	4	3	2	1	Bit 0
0x0000 SYNR	R	0	0	SYN5	SYN4	SYN3	SYN2	SYN1	SYN0
	W								
0x0001 REFDV	R	0	0	0	0	REFDV3	REFDV2	REFDV1	REFDV0
	W								
0x0002 CTFLG	R	0	0	0	0	0	0	0	0
	W								
0x0003 CRGFLG	R	RTIF	PORF	LVRF	LOCKIF	LOCK	TRACK	SCMIF	SCM
	W								
0x0004 CRGINT	R	RTIE	0	0	LOCKIE	0	0	SCMIE	0
	W								
0x0005 CLKSEL	R	PLLSEL	PSTP	SYSWAI	ROAWAI	PLLWAI	CWAI	RTIWAI	COPWAI
	W								
0x0006 PLLCTL	R	CME	PLLON	AUTO	ACQ	0	PRE	PCE	SCME
	W								
0x0007 RTICTL	R	0	RTR6	RTR5	RTR4	RTR3	RTR2	RTR1	RTR0
	W								
0x0008 COPCTL	R	WCOP	RSBCK	0	0	0	CR2	CR1	CR0
	W								
0x0009 FORBYP	R	0	0	0	0	0	0	0	0
	W								
0x000A CTCTL	R	0	0	0	0	0	0	0	0
	W								

= Unimplemented or Reserved

Figure 4-3. CRG Register Summary

Register Name		Bit 7	6	5	4	3	2	1	Bit 0
0x000B ARMCOP	R	0	0	0	0	0	0	0	0
	W	Bit 7	Bit 6	Bit 5	Bit 4	Bit 3	Bit 2	Bit 1	Bit 0

= Unimplemented or Reserved

Figure 4-3. CRG Register Summary (continued)

4.3.2.1 CRG Synthesizer Register (SYNR)

The SYNR register controls the multiplication factor of the PLL. If the PLL is on, the count in the loop divider (SYNR) register effectively multiplies up the PLL clock (PLLCLK) from the reference frequency by 2 x (SYNR+1). PLLCLK will not be below the minimum VCO frequency (f_{SCM}).

$$PLLCLK = 2 \times OSCCLK \times \frac{(SYNR + 1)}{(REFDV + 1)}$$

NOTE

If PLL is selected (PLLSEL=1), Bus Clock = PLLCLK / 2
 Bus Clock must not exceed the maximum operating system frequency.

Module Base + 0x0000

	7	6	5	4	3	2	1	0
R	0	0	SYN5	SYNR	SYN3	SYN2	SYN1	SYN0
W								
Reset	0	0	0	0	0	0	0	0

= Unimplemented or Reserved

Figure 4-4. CRG Synthesizer Register (SYNR)

Read: anytime

Write: anytime except if PLLSEL = 1

NOTE

Write to this register initializes the lock detector bit and the track detector bit.

4.3.2.2 CRG Reference Divider Register (REFDV)

The REFDV register provides a finer granularity for the PLL multiplier steps. The count in the reference divider divides OSCCLK frequency by REFDV + 1.

Module Base + 0x0001

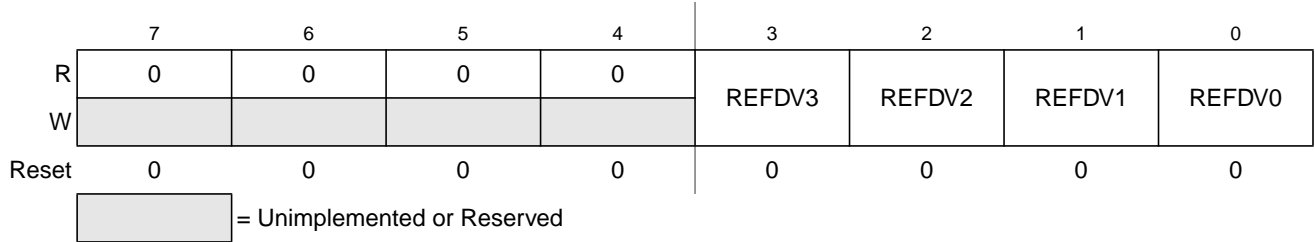

Figure 4-5. CRG Reference Divider Register (REFDV)

Read: anytime

Write: anytime except when PLLSEL = 1

NOTE

Write to this register initializes the lock detector bit and the track detector bit.

4.3.2.3 Reserved Register (CTFLG)

This register is reserved for factory testing of the CRGV4 module and is not available in normal modes.

Module Base + 0x0002

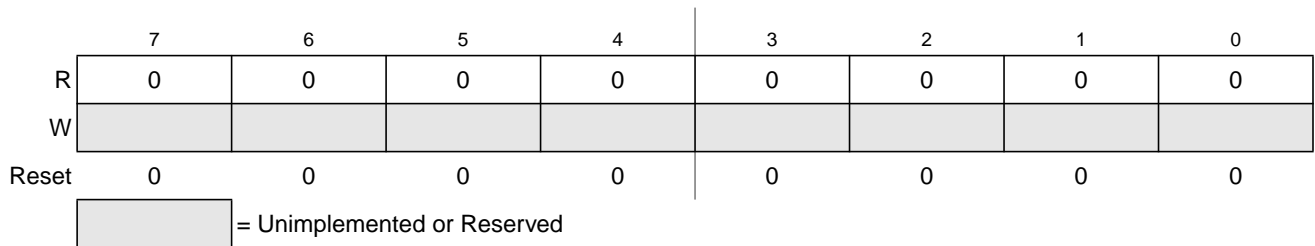

Figure 4-6. CRG Reserved Register (CTFLG)

Read: always reads 0x0000 in normal modes

Write: unimplemented in normal modes

NOTE

Writing to this register when in special mode can alter the CRGV4 functionality.

4.3.2.4 CRG Flags Register (CRGFLG)

This register provides CRG status bits and flags.

Module Base + 0x0003

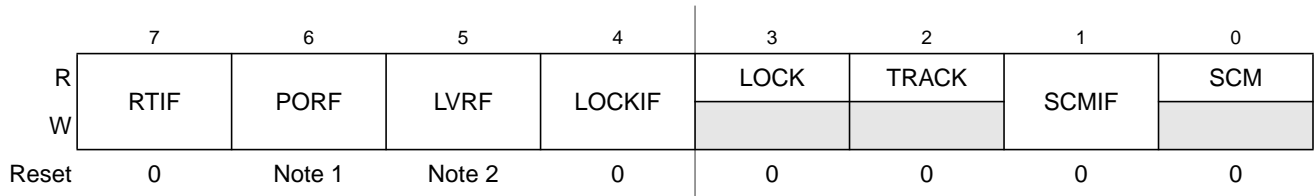

1. PORF is set to 1 when a power-on reset occurs. Unaffected by system reset.
2. LVRF is set to 1 when a low-voltage reset occurs. Unaffected by system reset.

= Unimplemented or Reserved

Figure 4-7. CRG Flag Register (CRGFLG)

Read: anytime

Write: refer to each bit for individual write conditions

Table 4-2. CRGFLG Field Descriptions

Field	Description
7 RTIF	Real-Time Interrupt Flag — RTIF is set to 1 at the end of the RTI period. This flag can only be cleared by writing a 1. Writing a 0 has no effect. If enabled (RTIE = 1), RTIF causes an interrupt request. 0 RTI time-out has not yet occurred. 1 RTI time-out has occurred.
6 PORF	Power-on Reset Flag — PORF is set to 1 when a power-on reset occurs. This flag can only be cleared by writing a 1. Writing a 0 has no effect. 0 Power-on reset has not occurred. 1 Power-on reset has occurred.
5 LVRF	Low-Voltage Reset Flag — If low voltage reset feature is not available (see the device overview chapter), LVRF always reads 0. LVRF is set to 1 when a low voltage reset occurs. This flag can only be cleared by writing a 1. Writing a 0 has no effect. 0 Low voltage reset has not occurred. 1 Low voltage reset has occurred.
4 LOCKIF	PLL Lock Interrupt Flag — LOCKIF is set to 1 when LOCK status bit changes. This flag can only be cleared by writing a 1. Writing a 0 has no effect. If enabled (LOCKIE = 1), LOCKIF causes an interrupt request. 0 No change in LOCK bit. 1 LOCK bit has changed.
3 LOCK	Lock Status Bit — LOCK reflects the current state of PLL lock condition. This bit is cleared in self-clock mode. Writes have no effect. 0 PLL VCO is not within the desired tolerance of the target frequency. 1 PLL VCO is within the desired tolerance of the target frequency.
2 TRACK	Track Status Bit — TRACK reflects the current state of PLL track condition. This bit is cleared in self-clock mode. Writes have no effect. 0 Acquisition mode status. 1 Tracking mode status.

Table 4-2. CRGFLG Field Descriptions (continued)

Field	Description
1 SCMIF	Self-Clock Mode Interrupt Flag — SCMIF is set to 1 when SCM status bit changes. This flag can only be cleared by writing a 1. Writing a 0 has no effect. If enabled (SCMIE=1), SCMIF causes an interrupt request. 0 No change in SCM bit. 1 SCM bit has changed.
0 SCM	Self-Clock Mode Status Bit — SCM reflects the current clocking mode. Writes have no effect. 0 MCU is operating normally with OSCCLK available. 1 MCU is operating in self-clock mode with OSCCLK in an unknown state. All clocks are derived from PLLCLK running at its minimum frequency f_{SCM} .

4.3.2.5 CRG Interrupt Enable Register (CRGINT)

This register enables CRG interrupt requests.

Module Base + 0x0004

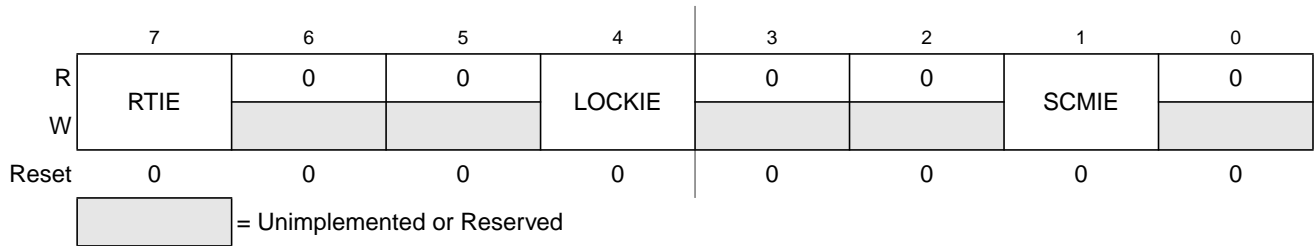

Figure 4-8. CRG Interrupt Enable Register (CRGINT)

Read: anytime

Write: anytime

Table 4-3. CRGINT Field Descriptions

Field	Description
7 RTIE	Real-Time Interrupt Enable Bit 0 Interrupt requests from RTI are disabled. 1 Interrupt will be requested whenever RTIF is set.
4 LOCKIE	Lock Interrupt Enable Bit 0 LOCK interrupt requests are disabled. 1 Interrupt will be requested whenever LOCKIF is set.
1 SCMIE	Self-Clock Mode Interrupt Enable Bit 0 SCM interrupt requests are disabled. 1 Interrupt will be requested whenever SCMIF is set.

4.3.2.6 CRG Clock Select Register (CLKSEL)

This register controls CRG clock selection. Refer to [Figure 4-17](#) for details on the effect of each bit.

Module Base + 0x0005

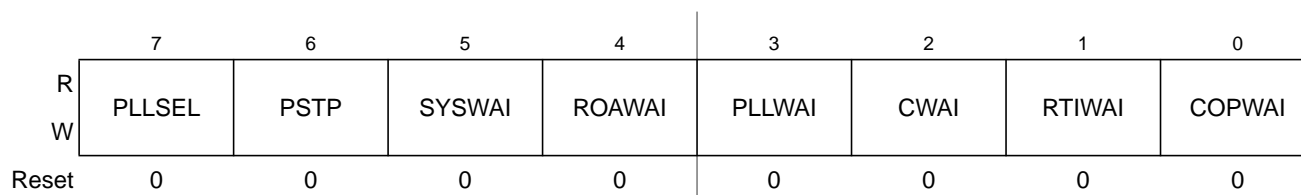

Figure 4-9. CRG Clock Select Register (CLKSEL)

Read: anytime

Write: refer to each bit for individual write conditions

Table 4-4. CLKSEL Field Descriptions

Field	Description
7 PLLSEL	<p>PLL Select Bit — Write anytime. Writing a 1 when LOCK = 0 and AUTO = 1, or TRACK = 0 and AUTO = 0 has no effect. This prevents the selection of an unstable PLLCLK as SYSCCLK. PLLSEL bit is cleared when the MCU enters self-clock mode, stop mode or wait mode with PLLWAI bit set.</p> <p>0 System clocks are derived from OSCCLK (Bus Clock = OSCCLK / 2).</p> <p>1 System clocks are derived from PLLCLK (Bus Clock = PLLCLK / 2).</p>
6 PSTP	<p>Pseudo-Stop Bit — Write: anytime — This bit controls the functionality of the oscillator during stop mode.</p> <p>0 Oscillator is disabled in stop mode.</p> <p>1 Oscillator continues to run in stop mode (pseudo-stop). The oscillator amplitude is reduced. Refer to oscillator block description for availability of a reduced oscillator amplitude.</p> <p>Note: Pseudo-stop allows for faster stop recovery and reduces the mechanical stress and aging of the resonator in case of frequent stop conditions at the expense of a slightly increased power consumption.</p> <p>Note: Lower oscillator amplitude exhibits lower power consumption but could have adverse effects during any electro-magnetic susceptibility (EMS) tests.</p>
5 SYSWAI	<p>System Clocks Stop in Wait Mode Bit — Write: anytime</p> <p>0 In wait mode, the system clocks continue to run.</p> <p>1 In wait mode, the system clocks stop.</p> <p>Note: RTI and COP are not affected by SYSWAI bit.</p>
4 ROAWAI	<p>Reduced Oscillator Amplitude in Wait Mode Bit — Write: anytime — Refer to oscillator block description chapter for availability of a reduced oscillator amplitude. If no such feature exists in the oscillator block then setting this bit to 1 will not have any effect on power consumption.</p> <p>0 Normal oscillator amplitude in wait mode.</p> <p>1 Reduced oscillator amplitude in wait mode.</p> <p>Note: Lower oscillator amplitude exhibits lower power consumption but could have adverse effects during any electro-magnetic susceptibility (EMS) tests.</p>
3 PLLWAI	<p>PLL Stops in Wait Mode Bit — Write: anytime — If PLLWAI is set, the CRGV4 will clear the PLLSEL bit before entering wait mode. The PLLON bit remains set during wait mode but the PLL is powered down. Upon exiting wait mode, the PLLSEL bit has to be set manually if PLL clock is required.</p> <p>While the PLLWAI bit is set the AUTO bit is set to 1 in order to allow the PLL to automatically lock on the selected target frequency after exiting wait mode.</p> <p>0 PLL keeps running in wait mode.</p> <p>1 PLL stops in wait mode.</p>

Table 4-4. CLKSEL Field Descriptions (continued)

Field	Description
2 CWA1	Core Stops in Wait Mode Bit — Write: anytime 0 Core clock keeps running in wait mode. 1 Core clock stops in wait mode.
1 RTIWA1	RTI Stops in Wait Mode Bit — Write: anytime 0 RTI keeps running in wait mode. 1 RTI stops and initializes the RTI dividers whenever the part goes into wait mode.
0 COPWA1	COP Stops in Wait Mode Bit — Normal modes: Write once —Special modes: Write anytime 0 COP keeps running in wait mode. 1 COP stops and initializes the COP dividers whenever the part goes into wait mode.

4.3.2.7 CRG PLL Control Register (PLLCTL)

This register controls the PLL functionality.

Module Base + 0x0006

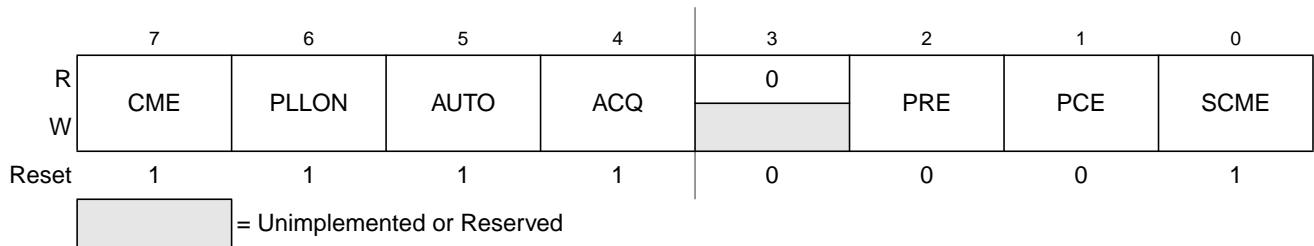

Figure 4-10. CRG PLL Control Register (PLLCTL)

Read: anytime

Write: refer to each bit for individual write conditions

Table 4-5. PLLCTL Field Descriptions

Field	Description
7 CME	Clock Monitor Enable Bit — CME enables the clock monitor. Write anytime except when SCM = 1. 0 Clock monitor is disabled. 1 Clock monitor is enabled. Slow or stopped clocks will cause a clock monitor reset sequence or self-clock mode. Note: Operating with CME = 0 will not detect any loss of clock. In case of poor clock quality this could cause unpredictable operation of the MCU. Note: In Stop Mode (PSTP = 0) the clock monitor is disabled independently of the CME bit setting and any loss of clock will not be detected.
6 PLLON	Phase Lock Loop On Bit — PLLON turns on the PLL circuitry. In self-clock mode, the PLL is turned on, but the PLLON bit reads the last latched value. Write anytime except when PLLSEL = 1. 0 PLL is turned off. 1 PLL is turned on. If AUTO bit is set, the PLL will lock automatically.

Table 4-5. PLLCTL Field Descriptions (continued)

Field	Description
5 AUTO	Automatic Bandwidth Control Bit — AUTO selects either the high bandwidth (acquisition) mode or the low bandwidth (tracking) mode depending on how close to the desired frequency the VCO is running. Write anytime except when PLLWAI=1, because PLLWAI sets the AUTO bit to 1. 0 Automatic mode control is disabled and the PLL is under software control, using ACQ bit. 1 Automatic mode control is enabled and ACQ bit has no effect.
4 ACQ	Acquisition Bit — Write anytime. If AUTO=1 this bit has no effect. 0 Low bandwidth filter is selected. 1 High bandwidth filter is selected.
2 PRE	RTI Enable during Pseudo-Stop Bit — PRE enables the RTI during pseudo-stop mode. Write anytime. 0 RTI stops running during pseudo-stop mode. 1 RTI continues running during pseudo-stop mode. Note: If the PRE bit is cleared the RTI dividers will go static while pseudo-stop mode is active. The RTI dividers will <u>not</u> initialize like in wait mode with RTIWAI bit set.
1 PCE	COP Enable during Pseudo-Stop Bit — PCE enables the COP during pseudo-stop mode. Write anytime. 0 COP stops running during pseudo-stop mode 1 COP continues running during pseudo-stop mode Note: If the PCE bit is cleared the COP dividers will go static while pseudo-stop mode is active. The COP dividers will <i>not</i> initialize like in wait mode with COPWAI bit set.
0 SCME	Self-Clock Mode Enable Bit — Normal modes: Write once —Special modes: Write anytime — SCME can not be cleared while operating in self-clock mode (SCM=1). 0 Detection of crystal clock failure causes clock monitor reset (see Section 4.5.1, “Clock Monitor Reset”). 1 Detection of crystal clock failure forces the MCU in self-clock mode (see Section 4.4.7.2, “Self-Clock Mode”).

4.3.2.8 CRG RTI Control Register (RTICTL)

This register selects the timeout period for the real-time interrupt.

Module Base + 0x0007

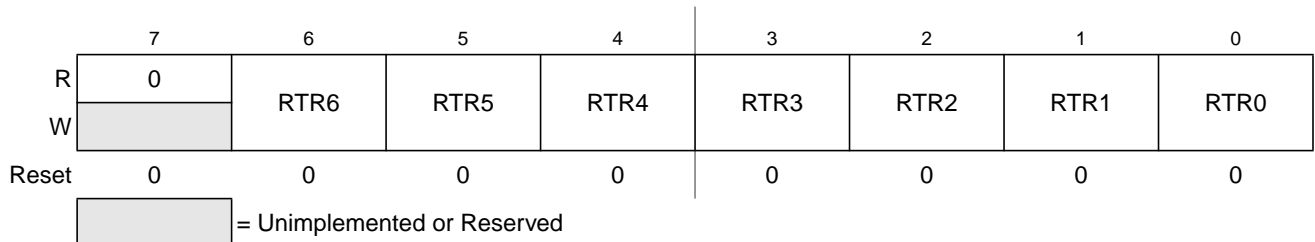

Figure 4-11. CRG RTI Control Register (RTICTL)

Read: anytime

Write: anytime

NOTE

A write to this register initializes the RTI counter.

Table 4-6. RTICTL Field Descriptions

Field	Description
6:4 RTR[6:4]	Real-Time Interrupt Prescale Rate Select Bits — These bits select the prescale rate for the RTI. See Table 4-7 .
3:0 RTR[3:0]	Real-Time Interrupt Modulus Counter Select Bits — These bits select the modulus counter target value to provide additional granularity. Table 4-7 shows all possible divide values selectable by the RTICTL register. The source clock for the RTI is OSCCLK.

Table 4-7. RTI Frequency Divide Rates

RTR[3:0]	RTR[6:4] =							
	000 (OFF)	001 (2^{10})	010 (2^{11})	011 (2^{12})	100 (2^{13})	101 (2^{14})	110 (2^{15})	111 (2^{16})
0000 (1)	OFF*	2^{10}	2^{11}	2^{12}	2^{13}	2^{14}	2^{15}	2^{16}
0001 (2)	OFF*	2×2^{10}	2×2^{11}	2×2^{12}	2×2^{13}	2×2^{14}	2×2^{15}	2×2^{16}
0010 (3)	OFF*	3×2^{10}	3×2^{11}	3×2^{12}	3×2^{13}	3×2^{14}	3×2^{15}	3×2^{16}
0011 (4)	OFF*	4×2^{10}	4×2^{11}	4×2^{12}	4×2^{13}	4×2^{14}	4×2^{15}	4×2^{16}
0100 (5)	OFF*	5×2^{10}	5×2^{11}	5×2^{12}	5×2^{13}	5×2^{14}	5×2^{15}	5×2^{16}
0101 (6)	OFF*	6×2^{10}	6×2^{11}	6×2^{12}	6×2^{13}	6×2^{14}	6×2^{15}	6×2^{16}
0110 (7)	OFF*	7×2^{10}	7×2^{11}	7×2^{12}	7×2^{13}	7×2^{14}	7×2^{15}	7×2^{16}
0111 (8)	OFF*	8×2^{10}	8×2^{11}	8×2^{12}	8×2^{13}	8×2^{14}	8×2^{15}	8×2^{16}
1000 (9)	OFF*	9×2^{10}	9×2^{11}	9×2^{12}	9×2^{13}	9×2^{14}	9×2^{15}	9×2^{16}
1001 (10)	OFF*	10×2^{10}	10×2^{11}	10×2^{12}	10×2^{13}	10×2^{14}	10×2^{15}	10×2^{16}
1010 (11)	OFF*	11×2^{10}	11×2^{11}	11×2^{12}	11×2^{13}	11×2^{14}	11×2^{15}	11×2^{16}
1011 (12)	OFF*	12×2^{10}	12×2^{11}	12×2^{12}	12×2^{13}	12×2^{14}	12×2^{15}	12×2^{16}
1100 (13)	OFF*	13×2^{10}	13×2^{11}	13×2^{12}	13×2^{13}	13×2^{14}	13×2^{15}	13×2^{16}
1101 (14)	OFF*	14×2^{10}	14×2^{11}	14×2^{12}	14×2^{13}	14×2^{14}	14×2^{15}	14×2^{16}
1110 (15)	OFF*	15×2^{10}	15×2^{11}	15×2^{12}	15×2^{13}	15×2^{14}	15×2^{15}	15×2^{16}
1111 (16)	OFF*	16×2^{10}	16×2^{11}	16×2^{12}	16×2^{13}	16×2^{14}	16×2^{15}	16×2^{16}

* Denotes the default value out of reset. This value should be used to disable the RTI to ensure future backwards compatibility.

4.3.2.9 CRG COP Control Register (COPCTL)

This register controls the COP (computer operating properly) watchdog.

Module Base + 0x0008

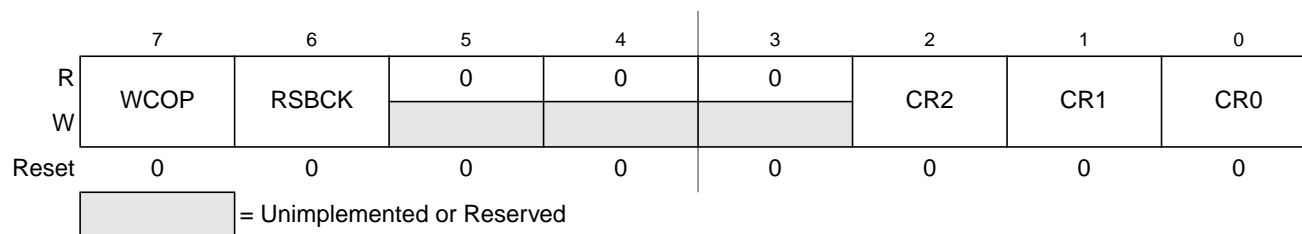

Figure 4-12. CRG COP Control Register (COPCTL)

Read: anytime

Write: WCOP, CR2, CR1, CR0: once in user mode, anytime in special mode

Write: RSBCK: once

Table 4-8. COPCTL Field Descriptions

Field	Description
7 WCOP	<p>Window COP Mode Bit — When set, a write to the ARMCOP register must occur in the last 25% of the selected period. A write during the first 75% of the selected period will reset the part. As long as all writes occur during this window, 0x0055 can be written as often as desired. As soon as 0x00AA is written after the 0x0055, the time-out logic restarts and the user must wait until the next window before writing to ARMCOP. Table 4-9 shows the exact duration of this window for the seven available COP rates.</p> <p>0 Normal COP operation 1 Window COP operation</p>
6 RSBCK	<p>COP and RTI Stop in Active BDM Mode Bit</p> <p>0 Allows the COP and RTI to keep running in active BDM mode. 1 Stops the COP and RTI counters whenever the part is in active BDM mode.</p>
2:0 CR[2:0]	<p>COP Watchdog Timer Rate Select — These bits select the COP time-out rate (see Table 4-9). The COP time-out period is OSCCLK period divided by CR[2:0] value. Writing a nonzero value to CR[2:0] enables the COP counter and starts the time-out period. A COP counter time-out causes a system reset. This can be avoided by periodically (before time-out) reinitializing the COP counter via the ARMCOP register.</p>

Table 4-9. COP Watchdog Rates¹

CR2	CR1	CR0	OSCCLK Cycles to Time Out
0	0	0	COP disabled
0	0	1	2 ¹⁴
0	1	0	2 ¹⁶
0	1	1	2 ¹⁸
1	0	0	2 ²⁰
1	0	1	2 ²²
1	1	0	2 ²³
1	1	1	2 ²⁴

¹ OSCCLK cycles are referenced from the previous COP time-out reset (writing 0x0055/0x00AA to the ARMCOP register)

4.3.2.10 Reserved Register (FORBYP)

NOTE

This reserved register is designed for factory test purposes only, and is not intended for general user access. Writing to this register when in special modes can alter the CRG's functionality.

Module Base + 0x0009

	7	6	5	4	3	2	1	0
R	0	0	0	0	0	0	0	0
W								
Reset	0	0	0	0	0	0	0	0

= Unimplemented or Reserved

Figure 4-13. Reserved Register (FORBYP)

Read: always read 0x0000 except in special modes

Write: only in special modes

4.3.2.11 Reserved Register (CTCTL)

NOTE

This reserved register is designed for factory test purposes only, and is not intended for general user access. Writing to this register when in special test modes can alter the CRG's functionality.

Module Base + 0x000A

	7	6	5	4	3	2	1	0
R	0	0	0	0	0	0	0	0
W								
Reset	0	0	0	0	0	0	0	0

= Unimplemented or Reserved

Figure 4-14. Reserved Register (CTCTL)

Read: always read 0x0080 except in special modes

Write: only in special modes

4.3.2.12 CRG COP Timer Arm/Reset Register (ARMCOP)

This register is used to restart the COP time-out period.

Module Base + 0x000B

	7	6	5	4	3	2	1	0
R	0	0	0	0	0	0	0	0
W	Bit 7	Bit 6	Bit 5	Bit 4	Bit 3	Bit 2	Bit 1	Bit 0
Reset	0	0	0	0	0	0	0	0

Figure 4-15. ARMCOP Register Diagram

Read: always reads 0x0000

Write: anytime

When the COP is disabled (CR[2:0] = “000”) writing to this register has no effect.

When the COP is enabled by setting CR[2:0] nonzero, the following applies:

Writing any value other than 0x0055 or 0x00AA causes a COP reset. To restart the COP time-out period you must write 0x0055 followed by a write of 0x00AA. Other instructions may be executed between these writes but the sequence (0x0055, 0x00AA) must be completed prior to COP end of time-out period to avoid a COP reset. Sequences of 0x0055 writes or sequences of 0x00AA writes are allowed. When the WCOP bit is set, 0x0055 and 0x00AA writes must be done in the last 25% of the selected time-out period; writing any value in the first 75% of the selected period will cause a COP reset.

4.4 Functional Description

This section gives detailed informations on the internal operation of the design.

4.4.1 Phase Locked Loop (PLL)

The PLL is used to run the MCU from a different time base than the incoming OSCCLK. For increased flexibility, OSCCLK can be divided in a range of 1 to 16 to generate the reference frequency. This offers a finer multiplication granularity. The PLL can multiply this reference clock by a multiple of 2, 4, 6,... 126,128 based on the SYNCR register.

$$PLLCLK = 2 \cdot OSCCLK \cdot \frac{[SYNCR + 1]}{[REFDV + 1]}$$

CAUTION

Although it is possible to set the two dividers to command a very high clock frequency, do not exceed the specified bus frequency limit for the MCU.
If (PLLSEL = 1), Bus Clock = PLLCLK / 2

The PLL is a frequency generator that operates in either acquisition mode or tracking mode, depending on the difference between the output frequency and the target frequency. The PLL can change between acquisition and tracking modes either automatically or manually.

The VCO has a minimum operating frequency, which corresponds to the self-clock mode frequency f_{SCM} .

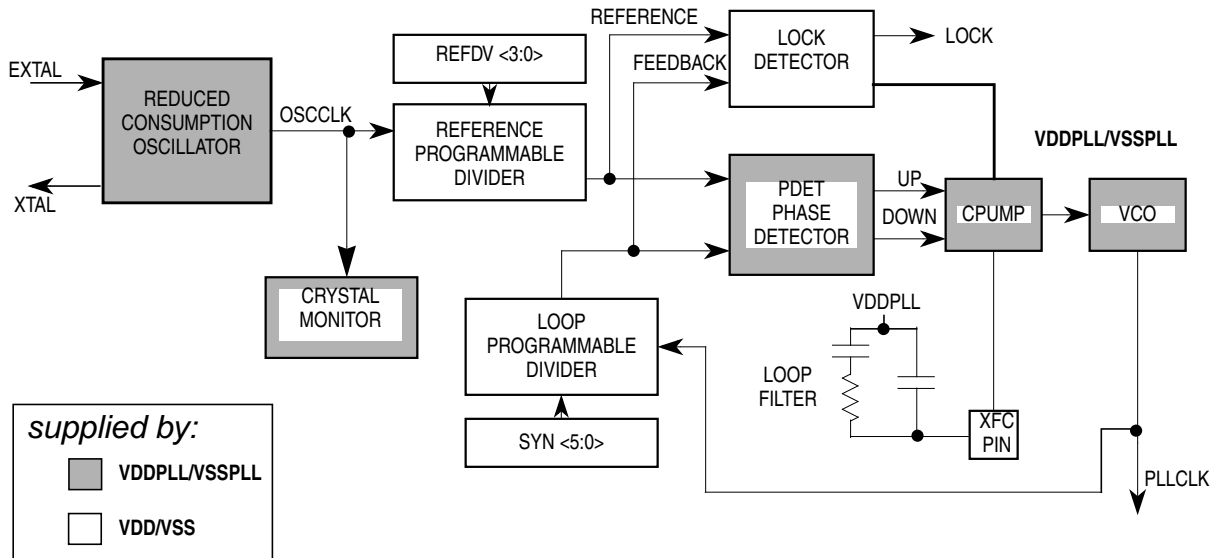

Figure 4-16. PLL Functional Diagram

4.4.1.1 PLL Operation

The oscillator output clock signal (OSCCLK) is fed through the reference programmable divider and is divided in a range of 1 to 16 ($REFDV+1$) to output the reference clock. The VCO output clock, (PLLCLK) is fed back through the programmable loop divider and is divided in a range of 2 to 128 in increments of $[2 \times (SYNR + 1)]$ to output the feedback clock. See [Figure 4-16](#).

The phase detector then compares the feedback clock, with the reference clock. Correction pulses are generated based on the phase difference between the two signals. The loop filter then slightly alters the DC voltage on the external filter capacitor connected to XFC pin, based on the width and direction of the correction pulse. The filter can make fast or slow corrections depending on its mode, as described in the next subsection. The values of the external filter network and the reference frequency determine the speed of the corrections and the stability of the PLL.

4.4.1.2 Acquisition and Tracking Modes

The lock detector compares the frequencies of the feedback clock, and the reference clock. Therefore, the speed of the lock detector is directly proportional to the final reference frequency. The circuit determines the mode of the PLL and the lock condition based on this comparison.

The PLL filter can be manually or automatically configured into one of two possible operating modes:

- Acquisition mode
In acquisition mode, the filter can make large frequency corrections to the VCO. This mode is used at PLL start-up or when the PLL has suffered a severe noise hit and the VCO frequency is far off the desired frequency. When in acquisition mode, the TRACK status bit is cleared in the CRGFLG register.
- Tracking mode
In tracking mode, the filter makes only small corrections to the frequency of the VCO. PLL jitter is much lower in tracking mode, but the response to noise is also slower. The PLL enters tracking mode when the VCO frequency is nearly correct and the TRACK bit is set in the CRGFLG register.

The PLL can change the bandwidth or operational mode of the loop filter manually or automatically.

In automatic bandwidth control mode ($AUTO = 1$), the lock detector automatically switches between acquisition and tracking modes. Automatic bandwidth control mode also is used to determine when the PLL clock (PLLCLK) is safe to use as the source for the system and core clocks. If PLL LOCK interrupt requests are enabled, the software can wait for an interrupt request and then check the LOCK bit. If CPU interrupts are disabled, software can poll the LOCK bit continuously (during PLL start-up, usually) or at periodic intervals. In either case, only when the LOCK bit is set, is the PLLCLK clock safe to use as the source for the system and core clocks. If the PLL is selected as the source for the system and core clocks and the LOCK bit is clear, the PLL has suffered a severe noise hit and the software must take appropriate action, depending on the application.

The following conditions apply when the PLL is in automatic bandwidth control mode ($AUTO = 1$):

- The TRACK bit is a read-only indicator of the mode of the filter.
- The TRACK bit is set when the VCO frequency is within a certain tolerance, Δ_{trk} , and is clear when the VCO frequency is out of a certain tolerance, Δ_{unt} .
- The LOCK bit is a read-only indicator of the locked state of the PLL.
- The LOCK bit is set when the VCO frequency is within a certain tolerance, Δ_{Lock} , and is cleared when the VCO frequency is out of a certain tolerance, Δ_{unl} .
- CPU interrupts can occur if enabled ($LOCKIE = 1$) when the lock condition changes, toggling the LOCK bit.

The PLL can also operate in manual mode ($AUTO = 0$). Manual mode is used by systems that do not require an indicator of the lock condition for proper operation. Such systems typically operate well below the maximum system frequency (f_{sys}) and require fast start-up. The following conditions apply when in manual mode:

- ACQ is a writable control bit that controls the mode of the filter. Before turning on the PLL in manual mode, the ACQ bit should be asserted to configure the filter in acquisition mode.
- After turning on the PLL by setting the PLLON bit software must wait a given time (t_{acq}) before entering tracking mode ($ACQ = 0$).
- After entering tracking mode software must wait a given time (t_{al}) before selecting the PLLCLK as the source for system and core clocks ($PLLSEL = 1$).

4.4.2 System Clocks Generator

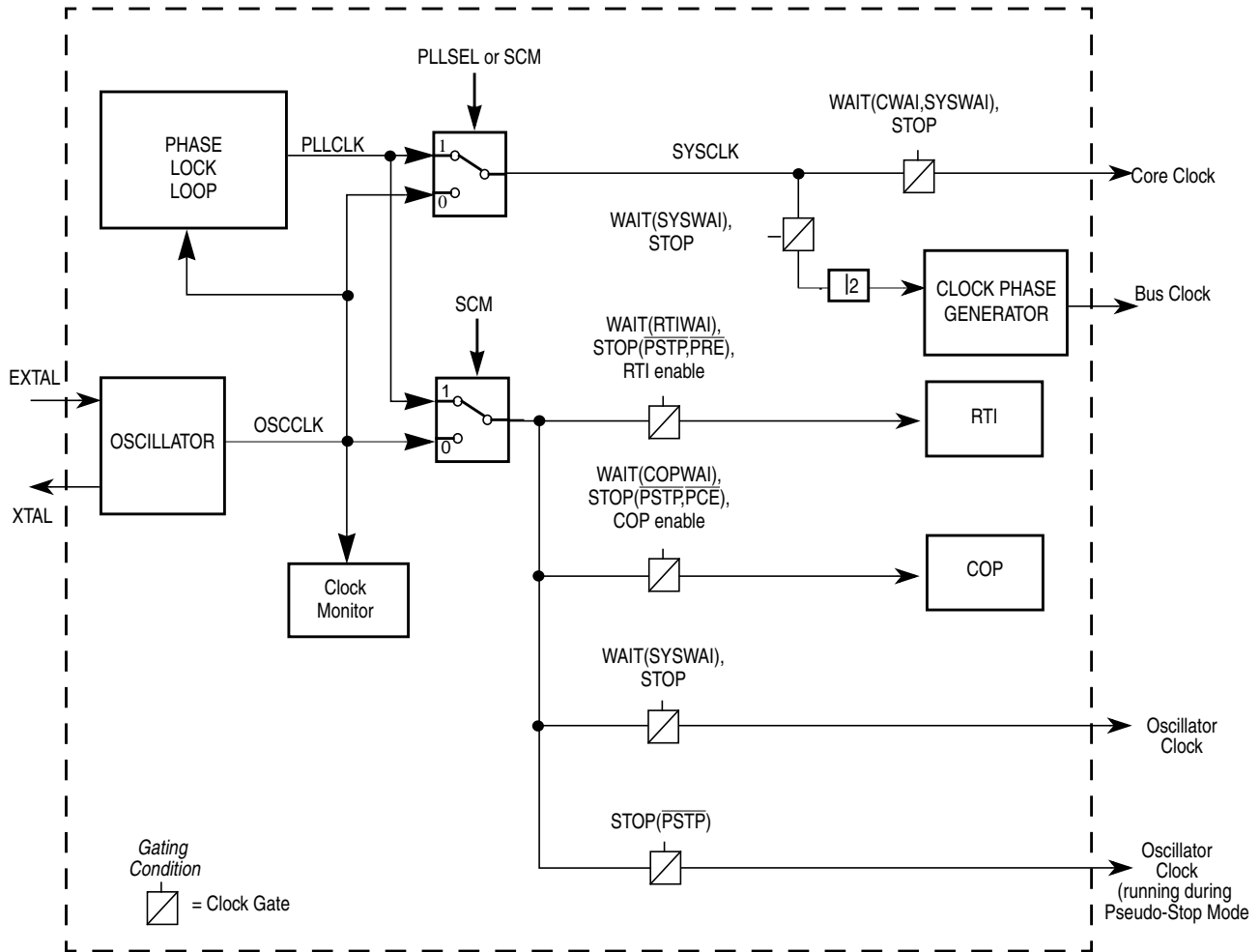

Figure 4-17. System Clocks Generator

The clock generator creates the clocks used in the MCU (see Figure 4-17). The gating condition placed on top of the individual clock gates indicates the dependencies of different modes (stop, wait) and the setting of the respective configuration bits.

The peripheral modules use the bus clock. Some peripheral modules also use the oscillator clock. The memory blocks use the bus clock. If the MCU enters self-clock mode (see Section 4.4.7.2, “Self-Clock Mode”), oscillator clock source is switched to PLLCLK running at its minimum frequency f_{SCM} . The bus clock is used to generate the clock visible at the ECLK pin. The core clock signal is the clock for the CPU. The core clock is twice the bus clock as shown in Figure 4-18. But note that a CPU cycle corresponds to one bus clock.

PLL clock mode is selected with PLLSEL bit in the CLKSEL register. When selected, the PLL output clock drives SYSCLK for the main system including the CPU and peripherals. The PLL cannot be turned off by clearing the PLLON bit, if the PLL clock is selected. When PLLSEL is changed, it takes a maximum

of 4 OSCCLK plus 4 PLLCLK cycles to make the transition. During the transition, all clocks freeze and CPU activity ceases.

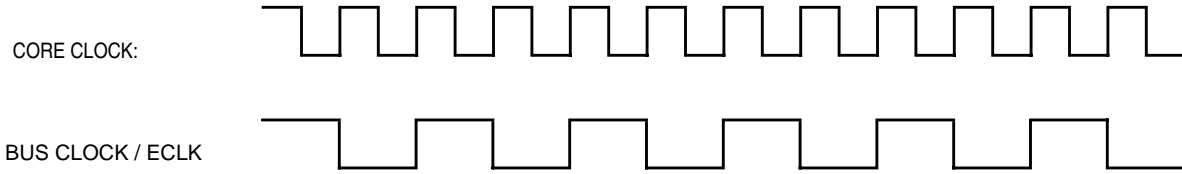

Figure 4-18. Core Clock and Bus Clock Relationship

4.4.3 Clock Monitor (CM)

If no OSCCLK edges are detected within a certain time, the clock monitor within the oscillator block generates a clock monitor fail event. The CRGV4 then asserts self-clock mode or generates a system reset depending on the state of SCME bit. If the clock monitor is disabled or the presence of clocks is detected no failure is indicated by the oscillator block. The clock monitor function is enabled/disabled by the CME control bit.

4.4.4 Clock Quality Checker

The clock monitor performs a coarse check on the incoming clock signal. The clock quality checker provides a more accurate check in addition to the clock monitor.

A clock quality check is triggered by any of the following events:

- Power-on reset (POR)
- Low voltage reset (LVR)
- Wake-up from full stop mode (exit full stop)
- Clock monitor fail indication (CM fail)

A time window of 50000 VCO clock cycles¹ is called *check window*.

A number greater equal than 4096 rising OSCCLK edges within a *check window* is called *osc ok*. Note that *osc ok* immediately terminates the current *check window*. See Figure 4-19 as an example.

1. VCO clock cycles are generated by the PLL when running at minimum frequency f_{SCM} .

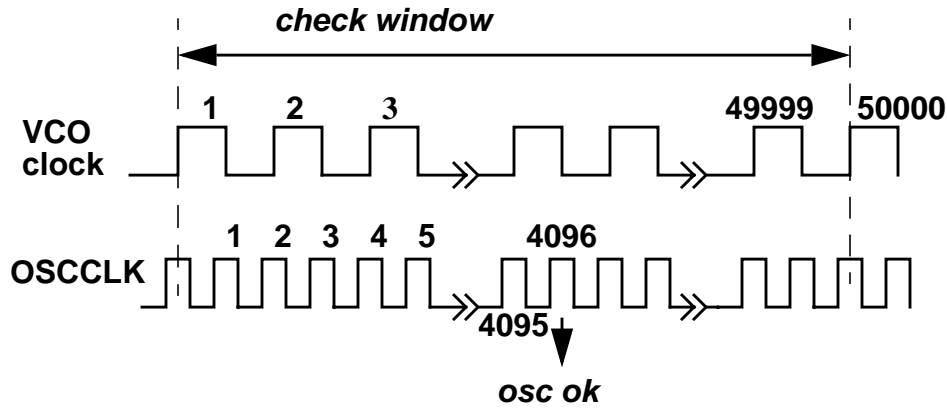

Figure 4-19. Check Window Example

The sequence for clock quality check is shown in Figure 4-20.

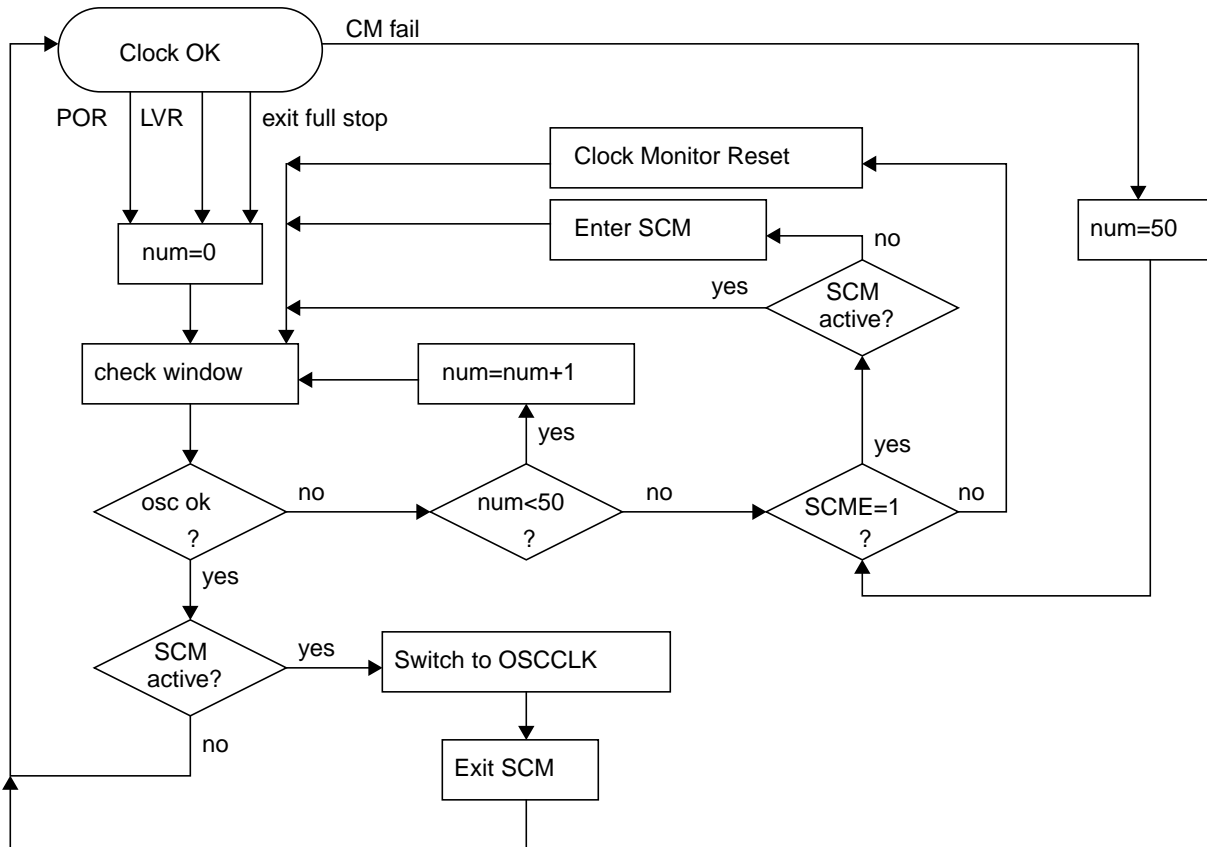

Figure 4-20. Sequence for Clock Quality Check

NOTE

Remember that in parallel to additional actions caused by self-clock mode or clock monitor reset¹ handling the clock quality checker **continues** to check the OSCCLK signal.

1. A Clock Monitor Reset will always set the SCME bit to logical '1'

NOTE

The clock quality checker enables the PLL and the voltage regulator (VREG) anytime a clock check has to be performed. An ongoing clock quality check could also cause a running PLL (f_{SCM}) and an active VREG during pseudo-stop mode or wait mode

4.4.5 Computer Operating Properly Watchdog (COP)

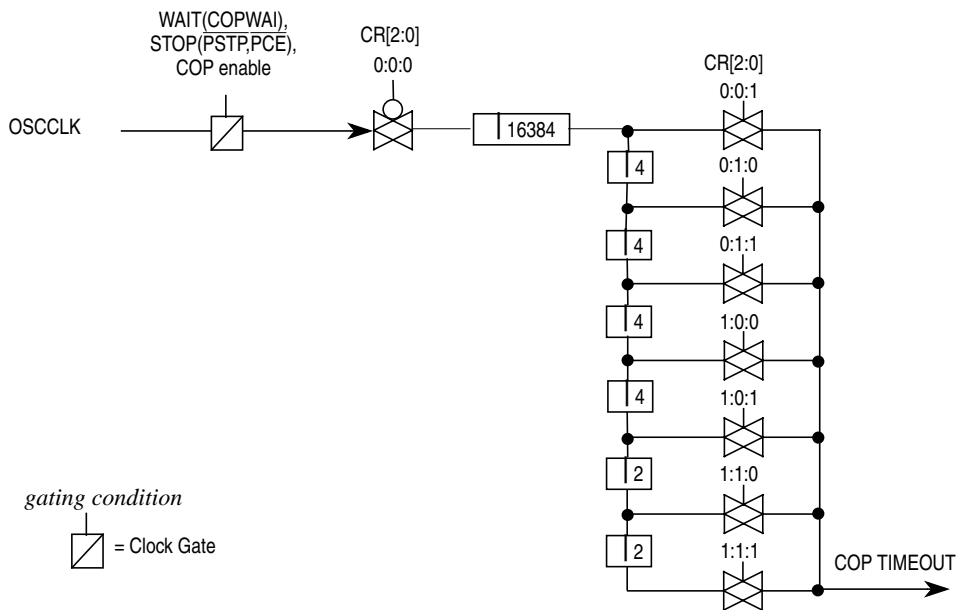

Figure 4-21. Clock Chain for COP

The COP (free running watchdog timer) enables the user to check that a program is running and sequencing properly. The COP is disabled out of reset. When the COP is being used, software is responsible for keeping the COP from timing out. If the COP times out it is an indication that the software is no longer being executed in the intended sequence; thus a system reset is initiated (see [Section 4.5.2, “Computer Operating Properly Watchdog \(COP\) Reset.”](#)) The COP runs with a gated OSCCLK (see [Section Figure 4-21., “Clock Chain for COP”](#)). Three control bits in the COPCTL register allow selection of seven COP time-out periods.

When COP is enabled, the program must write 0x0055 and 0x00AA (in this order) to the ARMCOP register during the selected time-out period. As soon as this is done, the COP time-out period is restarted. If the program fails to do this and the COP times out, the part will reset. Also, if any value other than 0x0055 or 0x00AA is written, the part is immediately reset.

Windowed COP operation is enabled by setting WCOP in the COPCTL register. In this mode, writes to the ARMCOP register to clear the COP timer must occur in the last 25% of the selected time-out period. A premature write will immediately reset the part.

If PCE bit is set, the COP will continue to run in pseudo-stop mode.

4.4.6 Real-Time Interrupt (RTI)

The RTI can be used to generate a hardware interrupt at a fixed periodic rate. If enabled (by setting RTIE=1), this interrupt will occur at the rate selected by the RTICTL register. The RTI runs with a gated OSCCLK (see Section Figure 4-22., “Clock Chain for RTI”). At the end of the RTI time-out period the RTIF flag is set to 1 and a new RTI time-out period starts immediately.

A write to the RTICTL register restarts the RTI time-out period.

If the PRE bit is set, the RTI will continue to run in pseudo-stop mode.

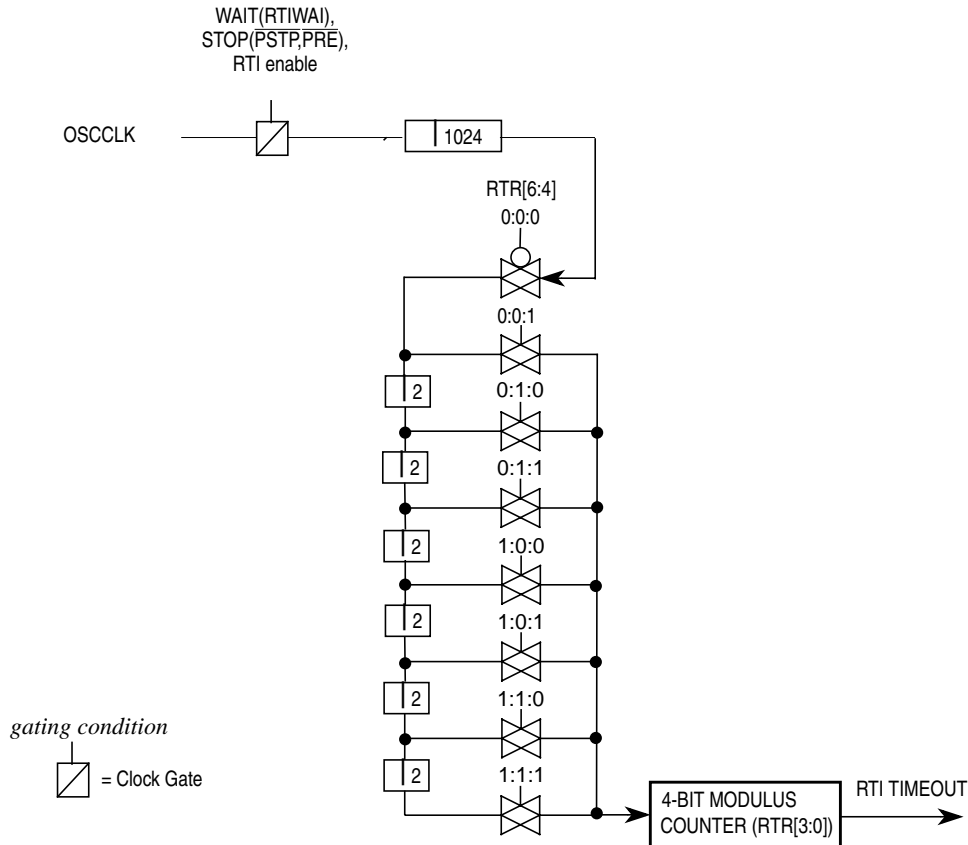

Figure 4-22. Clock Chain for RTI

4.4.7 Modes of Operation

4.4.7.1 Normal Mode

The CRGV4 block behaves as described within this specification in all normal modes.

4.4.7.2 Self-Clock Mode

The VCO has a minimum operating frequency, f_{SCM} . If the external clock frequency is not available due to a failure or due to long crystal start-up time, the bus clock and the core clock are derived from the VCO

running at minimum operating frequency; this mode of operation is called self-clock mode. This requires CME = 1 and SCME = 1. If the MCU was clocked by the PLL clock prior to entering self-clock mode, the PLLSEL bit will be cleared. If the external clock signal has stabilized again, the CRG will automatically select OSCCLK to be the system clock and return to normal mode. See [Section 4.4.4, “Clock Quality Checker”](#) for more information on entering and leaving self-clock mode.

NOTE

In order to detect a potential clock loss, the CME bit should be always enabled (CME=1).

If CME bit is disabled and the MCU is configured to run on PLL clock (PLLCLK), a loss of external clock (OSCCLK) will not be detected and will cause the system clock to drift towards the VCO’s minimum frequency f_{SCM} . As soon as the external clock is available again the system clock ramps up to its PLL target frequency. If the MCU is running on external clock any loss of clock will cause the system to go static.

4.4.8 Low-Power Operation in Run Mode

The RTI can be stopped by setting the associated rate select bits to 0.

The COP can be stopped by setting the associated rate select bits to 0.

4.4.9 Low-Power Operation in Wait Mode

The WAI instruction puts the MCU in a low power consumption stand-by mode depending on setting of the individual bits in the CLKSEL register. All individual wait mode configuration bits can be superposed. This provides enhanced granularity in reducing the level of power consumption during wait mode.

[Table 4-10](#) lists the individual configuration bits and the parts of the MCU that are affected in wait mode.

Table 4-10. MCU Configuration During Wait Mode

	PLLWAI	CWAI	SYSWAI	RTIWAI	COPWAI	ROAWAI
PLL	stopped	—	—	—	—	—
Core	—	stopped	stopped	—	—	—
System	—	—	stopped	—	—	—
RTI	—	—	—	stopped	—	—
COP	—	—	—	—	stopped	—
Oscillator	—	—	—	—	—	reduced ¹

¹ Refer to oscillator block description for availability of a reduced oscillator amplitude.

After executing the WAI instruction the core requests the CRG to switch MCU into wait mode. The CRG then checks whether the PLLWAI, CWAI and SYSWAI bits are asserted (see [Figure 4-23](#)). Depending on the configuration the CRG switches the system and core clocks to OSCCLK by clearing the PLLSEL bit, disables the PLL, disables the core clocks and finally disables the remaining system clocks. As soon as all clocks are switched off wait mode is active.

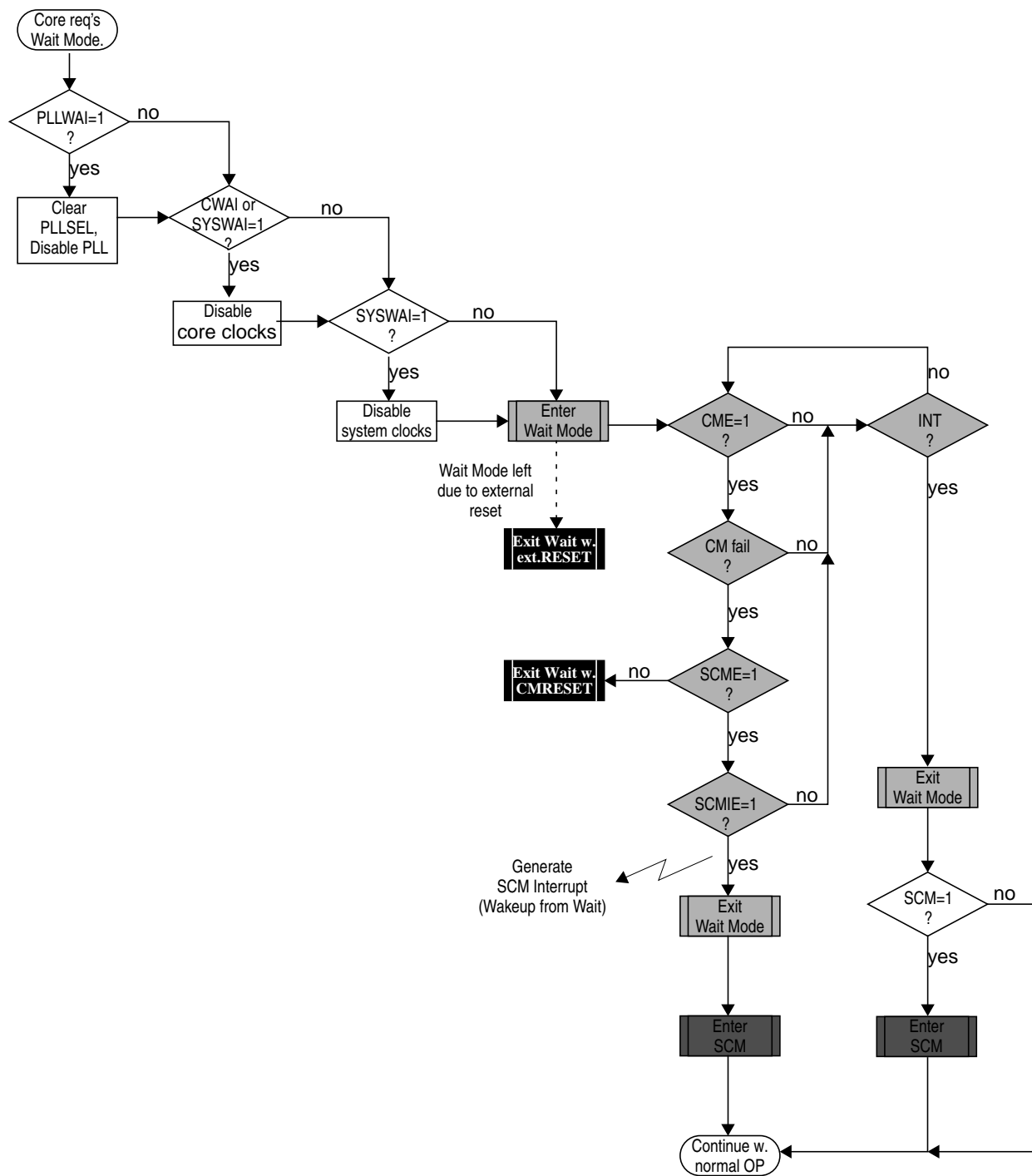

Figure 4-23. Wait Mode Entry/Exit Sequence

There are five different scenarios for the CRG to restart the MCU from wait mode:

- External reset
- Clock monitor reset
- COP reset
- Self-clock mode interrupt
- Real-time interrupt (RTI)

If the MCU gets an external reset during wait mode active, the CRG asynchronously restores all configuration bits in the register space to its default settings and starts the reset generator. After completing the reset sequence processing begins by fetching the normal reset vector. Wait mode is exited and the MCU is in run mode again.

If the clock monitor is enabled (CME=1) the MCU is able to leave wait mode when loss of oscillator/external clock is detected by a clock monitor fail. If the SCME bit is not asserted the CRG generates a clock monitor fail reset (CMRESET). The CRG's behavior for CMRESET is the same compared to external reset, but another reset vector is fetched after completion of the reset sequence. If the SCME bit is asserted the CRG generates a SCM interrupt if enabled (SCMIE=1). After generating the interrupt the CRG enters self-clock mode and starts the clock quality checker (see [Section 4.4.4, "Clock Quality Checker"](#)). Then the MCU continues with normal operation. If the SCM interrupt is blocked by SCMIE = 0, the SCMIF flag will be asserted and clock quality checks will be performed but the MCU will not wake-up from wait mode.

If any other interrupt source (e.g. RTI) triggers exit from wait mode the MCU immediately continues with normal operation. If the PLL has been powered-down during wait mode the PLLSEL bit is cleared and the MCU runs on OSCCLK after leaving wait mode. The software must manually set the PLLSEL bit again, in order to switch system and core clocks to the PLLCLK.

If wait mode is entered from self-clock mode, the CRG will continue to check the clock quality until clock check is successful. The PLL and voltage regulator (VREG) will remain enabled.

[Table 4-11](#) summarizes the outcome of a clock loss while in wait mode.

Table 4-11. Outcome of Clock Loss in Wait Mode

CME	SCME	SCMIE	CRG Actions
0	X	X	Clock failure --> No action, clock loss not detected.
1	0	X	Clock failure --> CRG performs Clock Monitor Reset immediately
1	1	0	<p>Clock failure --></p> <p>Scenario 1: OSCCLK recovers prior to exiting Wait Mode.</p> <ul style="list-style-type: none"> – MCU remains in Wait Mode, – VREG enabled, – PLL enabled, – SCM activated, – Start Clock Quality Check, – Set SCMIF interrupt flag. <p><i>Some time later OSCCLK recovers.</i></p> <ul style="list-style-type: none"> – CM no longer indicates a failure, – 4096 OSCCLK cycles later Clock Quality Check indicates clock o.k., – SCM deactivated, – PLL disabled depending on PLLWAI, – VREG remains enabled (<i>never gets disabled in Wait Mode</i>). – MCU remains in Wait Mode. <p><i>Some time later either a wakeup interrupt occurs (no SCM interrupt)</i></p> <ul style="list-style-type: none"> – Exit Wait Mode using OSCCLK as system clock (SYSCLK), – Continue normal operation. <p><i>or an External Reset is applied.</i></p> <ul style="list-style-type: none"> – Exit Wait Mode using OSCCLK as system clock, – Start reset sequence. <p>Scenario 2: OSCCLK does not recover prior to exiting Wait Mode.</p> <ul style="list-style-type: none"> – MCU remains in Wait Mode, – VREG enabled, – PLL enabled, – SCM activated, – Start Clock Quality Check, – Set SCMIF interrupt flag, – Keep performing Clock Quality Checks (could continue infinitely) while in Wait Mode. <p><i>Some time later either a wakeup interrupt occurs (no SCM interrupt)</i></p> <ul style="list-style-type: none"> – Exit Wait Mode in SCM using PLL clock (f_{SCM}) as system clock, – Continue to perform additional Clock Quality Checks until OSCCLK is o.k. again. <p><i>or an External RESET is applied.</i></p> <ul style="list-style-type: none"> – Exit Wait Mode in SCM using PLL clock (f_{SCM}) as system clock, – Start reset sequence, – Continue to perform additional Clock Quality Checks until OSCCLK is o.k. again.

Table 4-11. Outcome of Clock Loss in Wait Mode (continued)

CME	SCME	SCMIE	CRG Actions
1	1	1	Clock failure --> <ul style="list-style-type: none"> – VREG enabled, – PLL enabled, – SCM activated, – Start Clock Quality Check, – SCMIF set. SCMIF generates Self-Clock Mode wakeup interrupt. <ul style="list-style-type: none"> – Exit Wait Mode in SCM using PLL clock (f_{SCM}) as system clock, – Continue to perform a additional Clock Quality Checks until OSCCLK is o.k. again.

4.4.10 Low-Power Operation in Stop Mode

All clocks are stopped in STOP mode, dependent of the setting of the PCE, PRE and PSTP bit. The oscillator is disabled in STOP mode unless the PSTP bit is set. All counters and dividers remain frozen but do not initialize. If the PRE or PCE bits are set, the RTI or COP continues to run in pseudo-stop mode. In addition to disabling system and core clocks the CRG requests other functional units of the MCU (e.g. voltage-regulator) to enter their individual power-saving modes (if available). This is the main difference between pseudo-stop mode and wait mode.

After executing the STOP instruction the core requests the CRG to switch the MCU into stop mode. If the PLLSEL bit remains set when entering stop mode, the CRG will switch the system and core clocks to OSCCLK by clearing the PLLSEL bit. Then the CRG disables the PLL, disables the core clock and finally disables the remaining system clocks. As soon as all clocks are switched off, stop mode is active.

If pseudo-stop mode ($PSTP = 1$) is entered from self-clock mode the CRG will continue to check the clock quality until clock check is successful. The PLL and the voltage regulator (VREG) will remain enabled. If full stop mode ($PSTP = 0$) is entered from self-clock mode an ongoing clock quality check will be stopped. A complete timeout window check will be started when stop mode is exited again.

Wake-up from stop mode also depends on the setting of the PSTP bit.

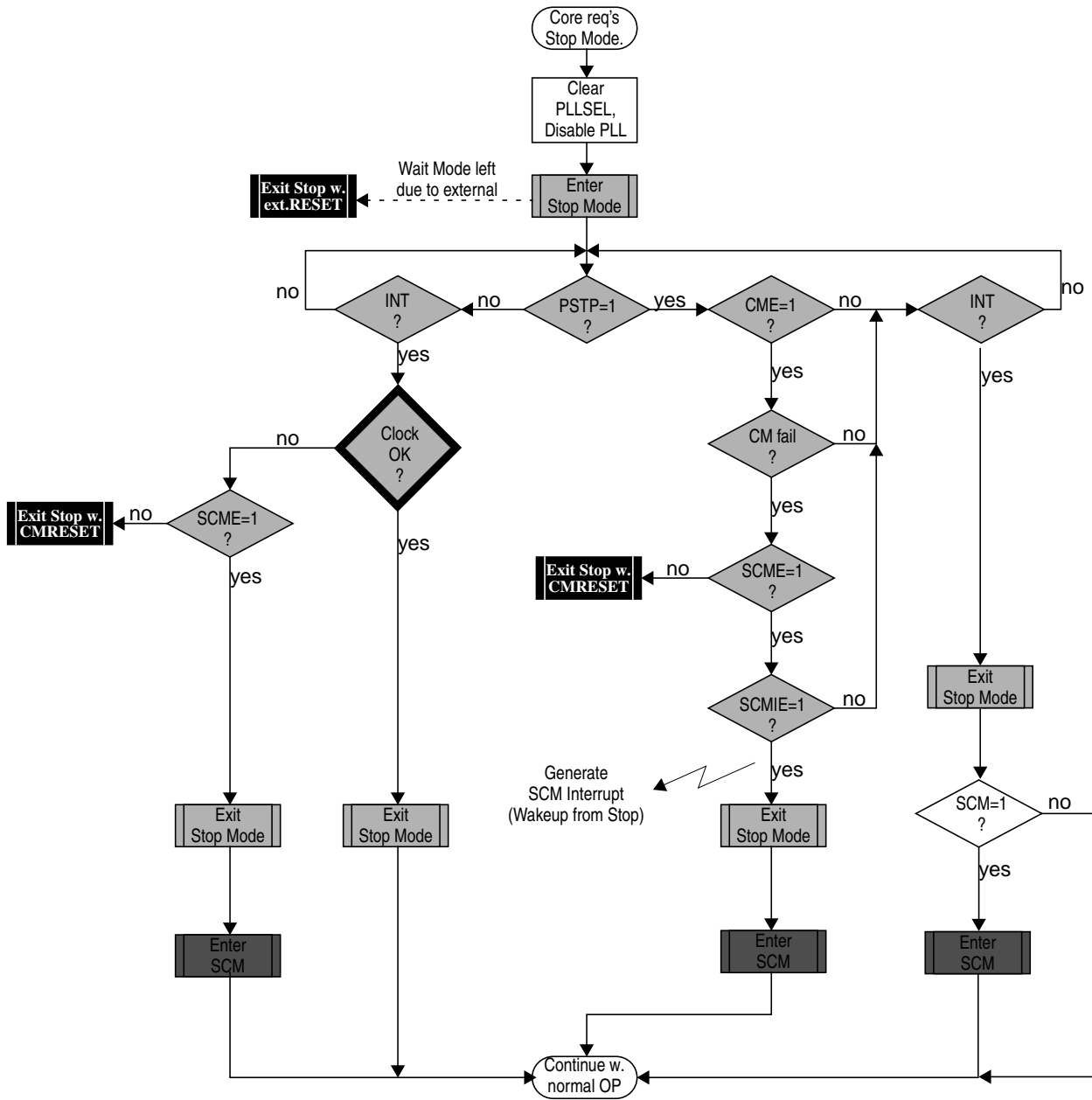

Figure 4-24. Stop Mode Entry/Exit Sequence

4.4.10.1 Wake-Up from Pseudo-Stop (PSTP=1)

Wake-up from pseudo-stop is the same as wake-up from wait mode. There are also three different scenarios for the CRG to restart the MCU from pseudo-stop mode:

- External reset
- Clock monitor fail
- Wake-up interrupt

If the MCU gets an external reset during pseudo-stop mode active, the CRG asynchronously restores all configuration bits in the register space to its default settings and starts the reset generator. After completing the reset sequence processing begins by fetching the normal reset vector. Pseudo-stop mode is exited and the MCU is in run mode again.

If the clock monitor is enabled ($CME = 1$) the MCU is able to leave pseudo-stop mode when loss of oscillator/external clock is detected by a clock monitor fail. If the SCME bit is not asserted the CRG generates a clock monitor fail reset (CMRESET). The CRG's behavior for CMRESET is the same compared to external reset, but another reset vector is fetched after completion of the reset sequence. If the SCME bit is asserted the CRG generates a SCM interrupt if enabled ($SCMIE=1$). After generating the interrupt the CRG enters self-clock mode and starts the clock quality checker (see [Section 4.4.4, "Clock Quality Checker"](#)). Then the MCU continues with normal operation. If the SCM interrupt is blocked by $SCMIE = 0$, the SCMIF flag will be asserted but the CRG will not wake-up from pseudo-stop mode.

If any other interrupt source (e.g. RTI) triggers exit from pseudo-stop mode the MCU immediately continues with normal operation. Because the PLL has been powered-down during stop mode the PLLSEL bit is cleared and the MCU runs on OSCCLK after leaving stop mode. The software must set the PLLSEL bit again, in order to switch system and core clocks to the PLLCLK.

[Table 4-12](#) summarizes the outcome of a clock loss while in pseudo-stop mode.

Table 4-12. Outcome of Clock Loss in Pseudo-Stop Mode

CME	SCME	SCMIE	CRG Actions
0	X	X	Clock failure --> No action, clock loss not detected.
1	0	X	Clock failure --> CRG performs Clock Monitor Reset immediately
1	1	0	<p>Clock Monitor failure --></p> <p>Scenario 1: OSCCLK recovers prior to exiting Pseudo-Stop Mode.</p> <ul style="list-style-type: none"> – MCU remains in Pseudo-Stop Mode, – VREG enabled, – PLL enabled, – SCM activated, – Start Clock Quality Check, – Set SCMIF interrupt flag. <p><i>Some time later OSCCLK recovers.</i></p> <ul style="list-style-type: none"> – CM no longer indicates a failure, – 4096 OSCCLK cycles later Clock Quality Check indicates clock o.k., – SCM deactivated, – PLL disabled, – VREG disabled. – MCU remains in Pseudo-Stop Mode. <p><i>Some time later either a wakeup interrupt occurs (no SCM interrupt)</i></p> <ul style="list-style-type: none"> – Exit Pseudo-Stop Mode using OSCCLK as system clock (SYSCLK), – Continue normal operation. <p><i>or an External Reset is applied.</i></p> <ul style="list-style-type: none"> – Exit Pseudo-Stop Mode using OSCCLK as system clock, – Start reset sequence. <p>Scenario 2: OSCCLK does not recover prior to exiting Pseudo-Stop Mode.</p> <ul style="list-style-type: none"> – MCU remains in Pseudo-Stop Mode, – VREG enabled, – PLL enabled, – SCM activated, – Start Clock Quality Check, – Set SCMIF interrupt flag, – Keep performing Clock Quality Checks (could continue infinitely) while in Pseudo-Stop Mode. <p><i>Some time later either a wakeup interrupt occurs (no SCM interrupt)</i></p> <ul style="list-style-type: none"> – Exit Pseudo-Stop Mode in SCM using PLL clock (f_{SCM}) as system clock – Continue to perform additional Clock Quality Checks until OSCCLK is o.k. again. <p><i>or an External RESET is applied.</i></p> <ul style="list-style-type: none"> – Exit Pseudo-Stop Mode in SCM using PLL clock (f_{SCM}) as system clock – Start reset sequence, – Continue to perform additional Clock Quality Checks until OSCCLK is o.k.again.

Table 4-12. Outcome of Clock Loss in Pseudo-Stop Mode (continued)

CME	SCME	SCMIE	CRG Actions
1	1	1	Clock failure --> <ul style="list-style-type: none"> – VREG enabled, – PLL enabled, – SCM activated, – Start Clock Quality Check, – SCMIF set. SCMIF generates Self-Clock Mode wakeup interrupt. <ul style="list-style-type: none"> – Exit Pseudo-Stop Mode in SCM using PLL clock (f_{SCM}) as system clock, – Continue to perform a additional Clock Quality Checks until OSCCLK is o.k. again.

4.4.10.2 Wake-up from Full Stop (PSTP=0)

The MCU requires an external interrupt or an external reset in order to wake-up from stop mode.

If the MCU gets an external reset during full stop mode active, the CRG asynchronously restores all configuration bits in the register space to its default settings and will perform a maximum of 50 clock *check_windows* (see [Section 4.4.4, “Clock Quality Checker”](#)). After completing the clock quality check the CRG starts the reset generator. After completing the reset sequence processing begins by fetching the normal reset vector. Full stop mode is exited and the MCU is in run mode again.

If the MCU is woken-up by an interrupt, the CRG will also perform a maximum of 50 clock *check_windows* (see [Section 4.4.4, “Clock Quality Checker”](#)). If the clock quality check is successful, the CRG will release all system and core clocks and will continue with normal operation. If all clock checks within the timeout-window are failing, the CRG will switch to self-clock mode or generate a clock monitor reset (CMRESET) depending on the setting of the SCME bit.

Because the PLL has been powered-down during stop mode the PLLSEL bit is cleared and the MCU runs on OSCCLK after leaving stop mode. The software must manually set the PLLSEL bit again, in order to switch system and core clocks to the PLLCLK.

NOTE

In full stop mode, the clock monitor is disabled and any loss of clock will not be detected.

4.5 Resets

This section describes how to reset the CRGV4 and how the CRGV4 itself controls the reset of the MCU. It explains all special reset requirements. Because the reset generator for the MCU is part of the CRG, this section also describes all automatic actions that occur during or as a result of individual reset conditions. The reset values of registers and signals are provided in [Section 4.3, “Memory Map and Register](#)

Definition. All reset sources are listed in [Table 4-13](#). Refer to the device overview chapter for related vector addresses and priorities.

Table 4-13. Reset Summary

Reset Source	Local Enable
Power-on Reset	None
Low Voltage Reset	None
External Reset	None
Clock Monitor Reset	PLLCTL (CME=1, SCME=0)
COP Watchdog Reset	COPCTL (CR[2:0] nonzero)

The reset sequence is initiated by any of the following events:

- Low level is detected at the $\overline{\text{RESET}}$ pin (external reset).
- Power on is detected.
- Low voltage is detected.
- COP watchdog times out.
- Clock monitor failure is detected and self-clock mode was disabled (SCME = 0).

Upon detection of any reset event, an internal circuit drives the $\overline{\text{RESET}}$ pin low for 128 SYSCLK cycles (see [Figure 4-25](#)). Because entry into reset is asynchronous it does not require a running SYSCLK. However, the internal reset circuit of the CRGV4 cannot sequence out of current reset condition without a running SYSCLK. The number of 128 SYSCLK cycles might be increased by $n = 3$ to 6 additional SYSCLK cycles depending on the internal synchronization latency. After $128+n$ SYSCLK cycles the $\overline{\text{RESET}}$ pin is released. The reset generator of the CRGV4 waits for additional 64 SYSCLK cycles and then samples the RESET pin to determine the originating source. [Table 4-14](#) shows which vector will be fetched.

Table 4-14. Reset Vector Selection

Sampled $\overline{\text{RESET}}$ Pin (64 Cycles After Release)	Clock Monitor Reset Pending	COP Reset Pending	Vector Fetch
1	0	0	POR / LVR / External Reset
1	1	X	Clock Monitor Reset
1	0	1	COP Reset
0	X	X	POR / LVR / External Reset with rise of $\overline{\text{RESET}}$ pin

NOTE

External circuitry connected to the $\overline{\text{RESET}}$ pin should not include a large capacitance that would interfere with the ability of this signal to rise to a valid logic 1 within 64 SYSCLK cycles after the low drive is released.

The internal reset of the MCU remains asserted while the reset generator completes the 192 SYSCLK long reset sequence. The reset generator circuitry always makes sure the internal reset is deasserted synchronously after completion of the 192 SYSCLK cycles. In case the $\overline{\text{RESET}}$ pin is externally driven low for more than these 192 SYSCLK cycles (external reset), the internal reset remains asserted too.

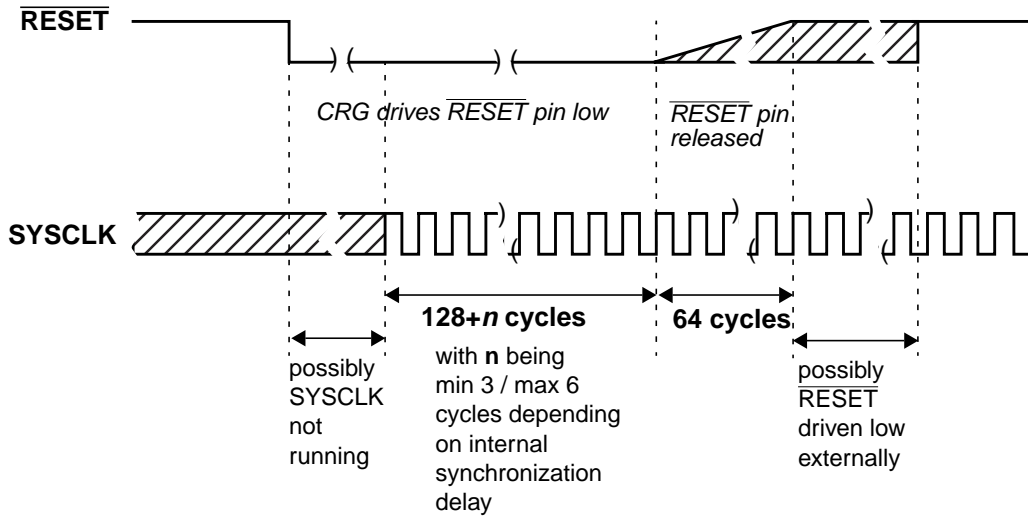

Figure 4-25. $\overline{\text{RESET}}$ Timing

4.5.1 Clock Monitor Reset

The CRGV4 generates a clock monitor reset in case all of the following conditions are true:

- Clock monitor is enabled (CME=1)
- Loss of clock is detected
- Self-clock mode is disabled (SCME=0)

The reset event asynchronously forces the configuration registers to their default settings (see [Section 4.3, “Memory Map and Register Definition”](#)). In detail the CME and the SCME are reset to logical ‘1’ (which doesn’t change the state of the CME bit, because it has already been set). As a consequence, the CRG immediately enters self-clock mode and starts its internal reset sequence. In parallel the clock quality check starts. As soon as clock quality check indicates a valid oscillator clock the CRG switches to OSCCLK and leaves self-clock mode. Because the clock quality checker is running in parallel to the reset generator, the CRG may leave self-clock mode while completing the internal reset sequence. When the reset sequence is finished the CRG checks the internally latched state of the clock monitor fail circuit. If a clock monitor fail is indicated processing begins by fetching the clock monitor reset vector.

4.5.2 Computer Operating Properly Watchdog (COP) Reset

When COP is enabled, the CRG expects sequential write of 0x0055 and 0x00AA (in this order) to the ARMCOP register during the selected time-out period. As soon as this is done, the COP time-out period restarts. If the program fails to do this the CRG will generate a reset. Also, if any value other than 0x0055 or 0x00AA is written, the CRG immediately generates a reset. In case windowed COP operation is enabled

writes (0x0055 or 0x00AA) to the ARMCOP register must occur in the last 25% of the selected time-out period. A premature write the CRG will immediately generate a reset.

As soon as the reset sequence is completed the reset generator checks the reset condition. If no clock monitor failure is indicated and the latched state of the COP timeout is true, processing begins by fetching the COP vector.

4.5.3 Power-On Reset, Low Voltage Reset

The on-chip voltage regulator detects when V_{DD} to the MCU has reached a certain level and asserts power-on reset or low voltage reset or both. As soon as a power-on reset or low voltage reset is triggered the CRG performs a quality check on the incoming clock signal. As soon as clock quality check indicates a valid oscillator clock signal the reset sequence starts using the oscillator clock. If after 50 check windows the clock quality check indicated a non-valid oscillator clock the reset sequence starts using self-clock mode.

Figure 4-26 and Figure 4-27 show the power-up sequence for cases when the $\overline{\text{RESET}}$ pin is tied to V_{DD} and when the $\overline{\text{RESET}}$ pin is held low.

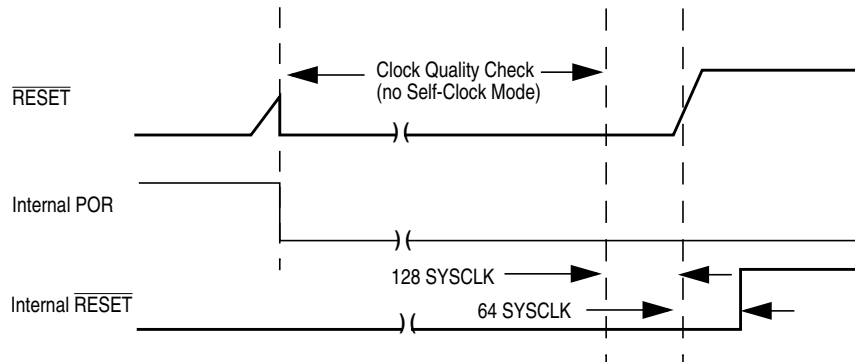

Figure 4-26. $\overline{\text{RESET}}$ Pin Tied to V_{DD} (by a Pull-Up Resistor)

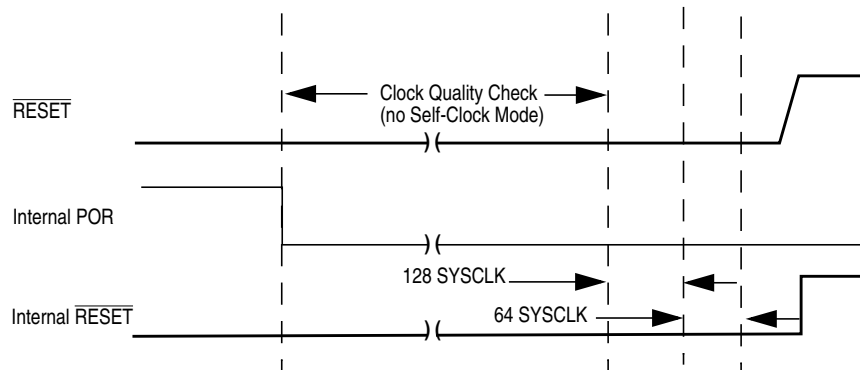

Figure 4-27. $\overline{\text{RESET}}$ Pin Held Low Externally

4.6 Interrupts

The interrupts/reset vectors requested by the CRG are listed in [Table 4-15](#). Refer to the device overview chapter for related vector addresses and priorities.

Table 4-15. CRG Interrupt Vectors

Interrupt Source	CCR Mask	Local Enable
Real-time interrupt	I bit	CRGINT (RTIE)
LOCK interrupt	I bit	CRGINT (LOCKIE)
SCM interrupt	I bit	CRGINT (SCMIE)

4.6.1 Real-Time Interrupt

The CRGV4 generates a real-time interrupt when the selected interrupt time period elapses. RTI interrupts are locally disabled by setting the RTIE bit to 0. The real-time interrupt flag (RTIF) is set to 1 when a timeout occurs, and is cleared to 0 by writing a 1 to the RTIF bit.

The RTI continues to run during pseudo-stop mode if the PRE bit is set to 1. This feature can be used for periodic wakeup from pseudo-stop if the RTI interrupt is enabled.

4.6.2 PLL Lock Interrupt

The CRGV4 generates a PLL lock interrupt when the LOCK condition of the PLL has changed, either from a locked state to an unlocked state or vice versa. Lock interrupts are locally disabled by setting the LOCKIE bit to 0. The PLL Lock interrupt flag (LOCKIF) is set to 1 when the LOCK condition has changed, and is cleared to 0 by writing a 1 to the LOCKIF bit.

4.6.3 Self-Clock Mode Interrupt

The CRGV4 generates a self-clock mode interrupt when the SCM condition of the system has changed, either entered or exited self-clock mode. SCM conditions can only change if the self-clock mode enable bit (SCME) is set to 1. SCM conditions are caused by a failing clock quality check after power-on reset (POR) or low voltage reset (LVR) or recovery from full stop mode (PSTP = 0) or clock monitor failure. For details on the clock quality check refer to [Section 4.4.4, “Clock Quality Checker.”](#) If the clock monitor is enabled (CME = 1) a loss of external clock will also cause a SCM condition (SCME = 1).

SCM interrupts are locally disabled by setting the SCMIE bit to 0. The SCM interrupt flag (SCMIF) is set to 1 when the SCM condition has changed, and is cleared to 0 by writing a 1 to the SCMIF bit.

Chapter 5

Oscillator (OSCV2) Block Description

5.1 Introduction

The OSCV2 module provides two alternative oscillator concepts:

- A low noise and low power Colpitts oscillator with amplitude limitation control (ALC)
- A robust full swing Pierce oscillator with the possibility to feed in an external square wave

5.1.1 Features

The Colpitts OSCV2 option provides the following features:

- Amplitude limitation control (ALC) loop:
 - Low power consumption and low current induced RF emission
 - Sinusoidal waveform with low RF emission
 - Low crystal stress (an external damping resistor is not required)
 - Normal and low amplitude mode for further reduction of power and emission
- An external biasing resistor is not required

The Pierce OSC option provides the following features:

- Wider high frequency operation range
- No DC voltage applied across the crystal
- Full rail-to-rail (2.5 V nominal) swing oscillation with low EM susceptibility
- Fast start up

Common features:

- Clock monitor (CM)
- Operation from the V_{DDPLL} 2.5 V (nominal) supply rail

5.1.2 Modes of Operation

Two modes of operation exist:

- Amplitude limitation controlled Colpitts oscillator mode suitable for power and emission critical applications
- Full swing Pierce oscillator mode that can also be used to feed in an externally generated square wave suitable for high frequency operation and harsh environments

5.2 External Signal Description

This section lists and describes the signals that connect off chip.

5.2.1 V_{DDPLL} and V_{SSPLL} — PLL Operating Voltage, PLL Ground

These pins provide the operating voltage (V_{DDPLL}) and ground (V_{SSPLL}) for the OSCV2 circuitry. This allows the supply voltage to the OSCV2 to be independently bypassed.

5.2.2 EXTAL and XTAL — Clock/Crystal Source Pins

These pins provide the interface for either a crystal or a CMOS compatible clock to control the internal clock generator circuitry. EXTAL is the external clock input or the input to the crystal oscillator amplifier. XTAL is the output of the crystal oscillator amplifier. All the MCU internal system clocks are derived from the EXTAL input frequency. In full stop mode ($PSTP = 0$) the EXTAL pin is pulled down by an internal resistor of typical 200 k Ω .

NOTE

Freescale Semiconductor recommends an evaluation of the application board and chosen resonator or crystal by the resonator or crystal supplier.

The Crystal circuit is changed from standard.

The Colpitts circuit is not suited for overtone resonators and crystals.

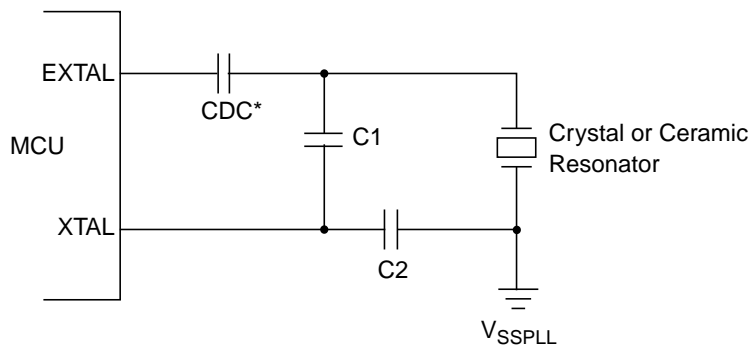

* Due to the nature of a translated ground Colpitts oscillator a DC voltage bias is applied to the crystal.

Please contact the crystal manufacturer for crystal DC bias conditions and recommended capacitor value CDC.

Figure 5-1. Colpitts Oscillator Connections (XCLKS = 0)

NOTE

The Pierce circuit is not suited for overtone resonators and crystals without a careful component selection.

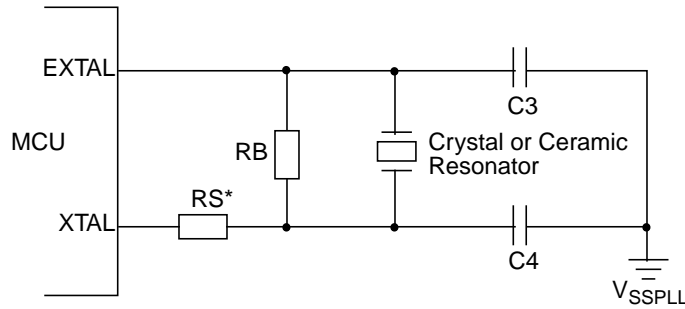

* Rs can be zero (shorted) when used with higher frequency crystals. Refer to manufacturer's data.

Figure 5-2. Pierce Oscillator Connections (XCLKS = 1)

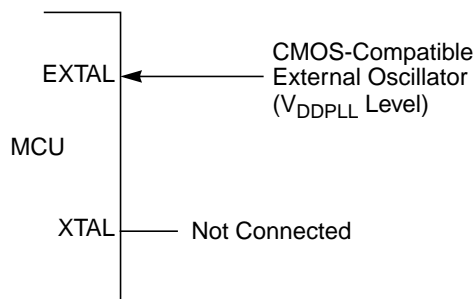

Figure 5-3. External Clock Connections (XCLKS = 1)

5.2.3 XCLKS — Colpitts/Pierce Oscillator Selection Signal

The XCLKS is an input signal which controls whether a crystal in combination with the internal Colpitts (low power) oscillator is used or whether the Pierce oscillator/external clock circuitry is used. The XCLKS signal is sampled during reset with the rising edge of $\overline{\text{RESET}}$. [Table 5-1](#) lists the state coding of the sampled XCLKS signal. Refer to the device overview chapter for polarity of the XCLKS pin.

Table 5-1. Clock Selection Based on XCLKS

XCLKS	Description
0	Colpitts oscillator selected
1	Pierce oscillator/external clock selected

5.3 Memory Map and Register Definition

The CRG contains the registers and associated bits for controlling and monitoring the OSCV2 module.

5.4 Functional Description

The OSCV2 block has two external pins, EXTAL and XTAL. The oscillator input pin, EXTAL, is intended to be connected to either a crystal or an external clock source. The selection of Colpitts oscillator or Pierce oscillator/external clock depends on the XCLKS signal which is sampled during reset. The XTAL pin is an output signal that provides crystal circuit feedback.

A buffered EXTAL signal, OSCCLK, becomes the internal reference clock. To improve noise immunity, the oscillator is powered by the V_{DDPLL} and V_{SSPLL} power supply pins.

The Pierce oscillator can be used for higher frequencies compared to the low power Colpitts oscillator.

5.4.1 Amplitude Limitation Control (ALC)

The Colpitts oscillator is equipped with a feedback system which does not waste current by generating harmonics. Its configuration is “Colpitts oscillator with translated ground.” The transistor used is driven by a current source under the control of a peak detector which will measure the amplitude of the AC signal appearing on EXTAL node in order to implement an amplitude limitation control (ALC) loop. The ALC loop is in charge of reducing the quiescent current in the transistor as a result of an increase in the oscillation amplitude. The oscillation amplitude can be limited to two values. The normal amplitude which is intended for non power saving modes and a small amplitude which is intended for low power operation modes. Please refer to the CRG block description chapter for the control and assignment of the amplitude value to operation modes.

5.4.2 Clock Monitor (CM)

The clock monitor circuit is based on an internal resistor-capacitor (RC) time delay so that it can operate without any MCU clocks. If no OSCCLK edges are detected within this RC time delay, the clock monitor indicates a failure which asserts self clock mode or generates a system reset depending on the state of SCME bit. If the clock monitor is disabled or the presence of clocks is detected no failure is indicated. The clock monitor function is enabled/disabled by the CME control bit, described in the CRG block description chapter.

5.5 Interrupts

OSCV2 contains a clock monitor, which can trigger an interrupt or reset. The control bits and status bits for the clock monitor are described in the CRG block description chapter.

Chapter 6

Analog-to-Digital Converter (ATD10B16CV4)

Block Description

6.1 Introduction

The ATD10B16C is a 16-channel, 10-bit, multiplexed input successive approximation analog-to-digital converter. Refer to the [Electrical Specifications](#) chapter for ATD accuracy.

6.1.1 Features

- 8-/10-bit resolution
- 7 μ s, 10-bit single conversion time
- Sample buffer amplifier
- Programmable sample time
- Left/right justified, signed/unsigned result data
- External trigger control
- Conversion completion interrupt generation
- Analog input multiplexer for 16 analog input channels
- Analog/digital input pin multiplexing
- 1 to 16 conversion sequence lengths
- Continuous conversion mode
- Multiple channel scans
- Configurable external trigger functionality on any AD channel or any of four additional trigger inputs. The four additional trigger inputs can be chip external or internal. Refer to device specification for availability and connectivity
- Configurable location for channel wrap around (when converting multiple channels in a sequence)

6.1.2 Modes of Operation

There is software programmable selection between performing **single** or **continuous conversion** on a **single channel** or **multiple channels**.

6.1.3 Block Diagram

Refer to [Figure 6-1](#) for a block diagram of the ATD0B16C block.

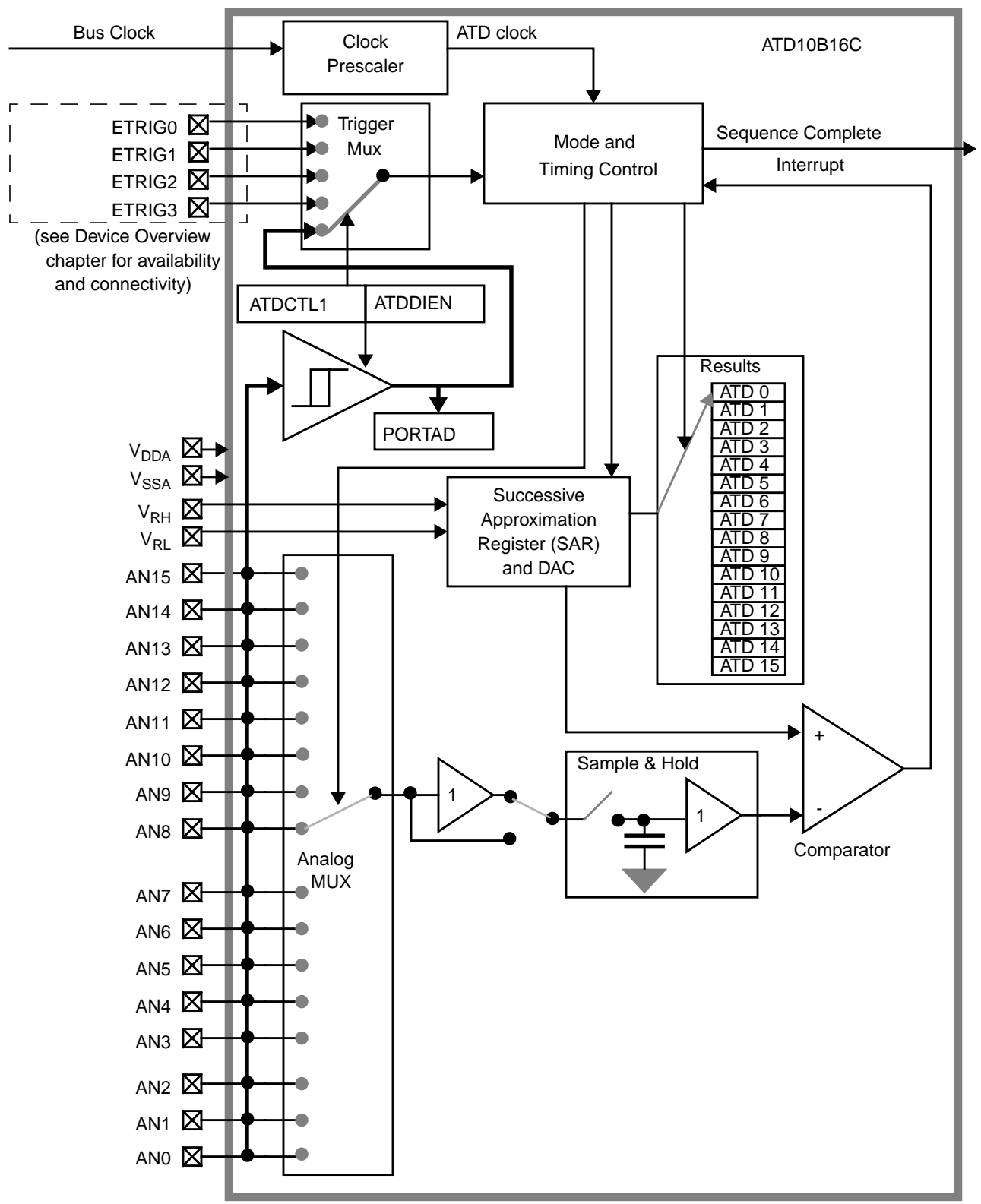

Figure 6-1. ATD10B16C Block Diagram

6.2 External Signal Description

This section lists all inputs to the ATD10B16C block.

6.2.1 AN x ($x = 15, 14, 13, 12, 11, 10, 9, 8, 7, 6, 5, 4, 3, 2, 1, 0$) — Analog Input Channel x Pins

This pin serves as the analog input channel x . It can also be configured as general-purpose digital input and/or external trigger for the ATD conversion.

6.2.2 ETRIG3, ETRIG2, ETRIG1, ETRIG0 — External Trigger Pins

These inputs can be configured to serve as an external trigger for the ATD conversion.

Refer to the [Device Overview](#) chapter for availability and connectivity of these inputs.

6.2.3 V_{RH} , V_{RL} — High Reference Voltage Pin, Low Reference Voltage Pin

V_{RH} is the high reference voltage, V_{RL} is the low reference voltage for ATD conversion.

6.2.4 V_{DDA} , V_{SSA} — Analog Circuitry Power Supply Pins

These pins are the power supplies for the analog circuitry of the ATD10B16CV4 block.

6.3 Memory Map and Register Definition

This section provides a detailed description of all registers accessible in the ATD10B16C.

6.3.1 Module Memory Map

[Table 6-1](#) gives an overview of all ATD10B16C registers

Table 6-1. ATD10B16CV4 Memory Map

Address Offset	Use	Access
0x0000	ATD Control Register 0 (ATDCTL0)	R/W
0x0001	ATD Control Register 1 (ATDCTL1)	R/W
0x0002	ATD Control Register 2 (ATDCTL2)	R/W
0x0003	ATD Control Register 3 (ATDCTL3)	R/W
0x0004	ATD Control Register 4 (ATDCTL4)	R/W
0x0005	ATD Control Register 5 (ATDCTL5)	R/W
0x0006	ATD Status Register 0 (ATDSTAT0)	R/W
0x0007	Unimplemented	
0x0008	ATD Test Register 0 (ATDTEST0) ¹	R
0x0009	ATD Test Register 1 (ATDTEST1)	R/W
0x000A	ATD Status Register 2 (ATDSTAT2)	R
0x000B	ATD Status Register 1 (ATDSTAT1)	R
0x000C	ATD Input Enable Register 0 (ATDDIEN0)	R/W
0x000D	ATD Input Enable Register 1 (ATDDIEN1)	R/W
0x000E	Port Data Register 0 (PORTAD0)	R
0x000F	Port Data Register 1 (PORTAD1)	R
0x0010, 0x0011	ATD Result Register 0 (ATDDR0H, ATDDR0L)	R/W
0x0012, 0x0013	ATD Result Register 1 (ATDDR1H, ATDDR1L)	R/W
0x0014, 0x0015	ATD Result Register 2 (ATDDR2H, ATDDR2L)	R/W
0x0016, 0x0017	ATD Result Register 3 (ATDDR3H, ATDDR3L)	R/W
0x0018, 0x0019	ATD Result Register 4 (ATDDR4H, ATDDR4L)	R/W
0x001A, 0x001B	ATD Result Register 5 (ATDDR5H, ATDDR5L)	R/W
0x001C, 0x001D	ATD Result Register 6 (ATDDR6H, ATDDR6L)	R/W
0x001E, 0x001F	ATD Result Register 7 (ATDDR7H, ATDDR7L)	R/W
0x0020, 0x0021	ATD Result Register 8 (ATDDR8H, ATDDR8L)	R/W
0x0022, 0x0023	ATD Result Register 9 (ATDDR9H, ATDDR9L)	R/W
0x0024, 0x0025	ATD Result Register 10 (ATDDR10H, ATDDR10L)	R/W
0x0026, 0x0027	ATD Result Register 11 (ATDDR11H, ATDDR11L)	R/W
0x0028, 0x0029	ATD Result Register 12 (ATDDR12H, ATDDR12L)	R/W
0x002A, 0x002B	ATD Result Register 13 (ATDDR13H, ATDDR13L)	R/W
0x002C, 0x002D	ATD Result Register 14 (ATDDR14H, ATDDR14L)	R/W
0x002E, 0x002F	ATD Result Register 15 (ATDDR15H, ATDDR15L)	R/W

¹ ATDTEST0 is intended for factory test purposes only.

NOTE

Register Address = Base Address + Address Offset, where the Base Address is defined at the MCU level and the Address Offset is defined at the module level.

6.3.2 Register Descriptions

This section describes in address order all the ATD10B16C registers and their individual bits.

Register Name		Bit 7	6	5	4	3	2	1	Bit 0
0x0000 ATDCTL0	R	0	0	0	0	WRAP3	WRAP2	WRAP1	WRAP0
	W								
0x0001 ATDCTL1	R	ETRIGSEL	0	0	0	ETRIGCH3	ETRIGCH2	ETRIGCH1	ETRIGCH0
	W								
0x0002 ATDCTL2	R	ADPU	AFFC	AWAI	ETRIGLE	ETRIGP	ETRIGE	ASCIE	ASCIF
	W								
0x0003 ATDCTL3	R	0	S8C	S4C	S2C	S1C	FIFO	FRZ1	FRZ0
	W								
0x0004 ATDCTL4	R	SRES8	SMP1	SMP0	PRS4	PRS3	PRS2	PRS1	PRS0
	W								
0x0005 ATDCTL5	R	DJM	DSGN	SCAN	MULT	CD	CC	CB	CA
	W								
0x0006 ATDSTAT0	R	SCF	0	ETORF	FIFOR	CC3	CC2	CC1	CC0
	W								
0x0007 Unimplemented	R								
	W								
0x0008 ATDTEST0	R	Unimplemented							
	W								
0x0009 ATDTEST1	R	Unimplemented							SC
	W								
0x000A ATDSTAT2	R	CCF15	CCF14	CCF13	CCF12	CCF11	CCF10	CCF9	CCF8
	W								
0x000B ATDSTAT1	R	CCF7	CCF6	CCF5	CCF4	CCF3	CCF2	CCF1	CCF0
	W								
0x000C ATDDIEN0	R	IEN15	IEN14	IEN13	IEN12	IEN11	IEN10	IEN9	IEN8
	W								

= Unimplemented or Reserved
 u = Unaffected

Figure 6-2. ATD Register Summary

Register Name		Bit 7	6	5	4	3	2	1	Bit 0
0x000D ATDDIEN1	R	IEN7	IEN6	IEN5	IEN4	IEN3	IEN2	IEN1	IEN0
	W								
0x000E PORTAD0	R	PTAD15	PTAD14	PTAD13	PTAD12	PTAD11	PTAD10	PTAD9	PTAD8
	W								
0x000F PORTAD1	R	PTAD7	PTAD6	PTAD5	PTAD4	PTAD3	PTAD2	PTAD1	PTAD0
	W								
0x0010–0x002F ATDDRxH– ATDDRxL	R	BIT 9 MSB BIT 7 MSB	BIT 8 BIT 6	BIT 7 BIT 5	BIT 6 BIT 4	BIT 5 BIT 3	BIT 4 BIT 2	BIT 3 BIT 1	BIT 2 BIT 0
	W								
	R	BIT 1 u	BIT 0 u	0 0	0 0	0 0	0 0	0 0	0 0
	W								

= Unimplemented or Reserved
 u = Unaffected

Figure 6-2. ATD Register Summary (continued)

6.3.2.1 ATD Control Register 0 (ATDCTL0)

Writes to this register will abort current conversion sequence but will not start a new sequence.

Module Base + 0x0000

	7	6	5	4	3	2	1	0
R	0	0	0	0	WRAP3	WRAP2	WRAP1	WRAP0
W								
Reset	0	0	0	0	1	1	1	1

= Unimplemented or Reserved

Figure 6-3. ATD Control Register 0 (ATDCTL0)

Read: Anytime

Write: Anytime

Table 6-2. ATDCTL0 Field Descriptions

Field	Description
3:0 WRAP[3:0]	Wrap Around Channel Select Bits — These bits determine the channel for wrap around when doing multi-channel conversions. The coding is summarized in Table 6-3 .

Table 6-3. Multi-Channel Wrap Around Coding

WRAP3	WRAP2	WRAP1	WRAP0	Multiple Channel Conversions (MULT = 1) Wrap Around to AN0 after Converting
0	0	0	0	Reserved
0	0	0	1	AN1
0	0	1	0	AN2
0	0	1	1	AN3
0	1	0	0	AN4
0	1	0	1	AN5
0	1	1	0	AN6
0	1	1	1	AN7
1	0	0	0	AN8
1	0	0	1	AN9
1	0	1	0	AN10
1	0	1	1	AN11
1	1	0	0	AN12
1	1	0	1	AN13
1	1	1	0	AN14
1	1	1	1	AN15

6.3.2.2 ATD Control Register 1 (ATDCTL1)

Writes to this register will abort current conversion sequence but will not start a new sequence.

Module Base + 0x0001

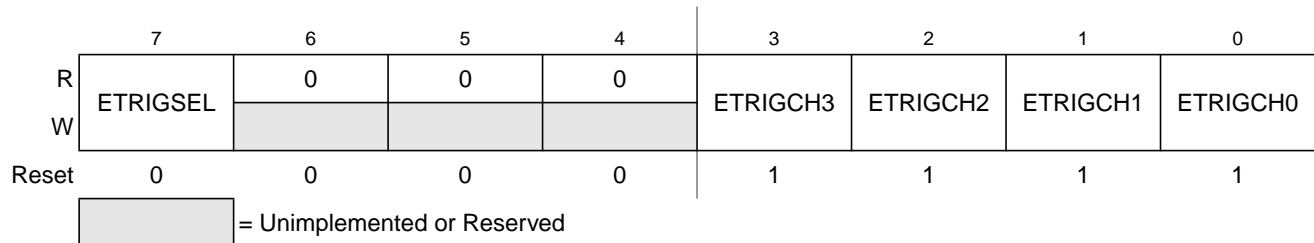

Figure 6-4. ATD Control Register 1 (ATDCTL1)

Read: Anytime

Write: Anytime

Table 6-4. ATDCTL1 Field Descriptions

Field	Description
7 ETRIGSEL	External Trigger Source Select — This bit selects the external trigger source to be either one of the AD channels or one of the ETRIG[3:0] inputs. See device specification for availability and connectivity of ETRIG[3:0] inputs. If ETRIG[3:0] input option is not available, writing a 1 to ETRISEL only sets the bit but has no effect, that means one of the AD channels (selected by ETRIGCH[3:0]) remains the source for external trigger. The coding is summarized in Table 6-5 .
3:0 ETRIGCH[3:0]	External Trigger Channel Select — These bits select one of the AD channels or one of the ETRIG[3:0] inputs as source for the external trigger. The coding is summarized in Table 6-5 .

Table 6-5. External Trigger Channel Select Coding

ETRIGSEL	ETRIGCH3	ETRIGCH2	ETRIGCH1	ETRIGCH0	External Trigger Source
0	0	0	0	0	AN0
0	0	0	0	1	AN1
0	0	0	1	0	AN2
0	0	0	1	1	AN3
0	0	1	0	0	AN4
0	0	1	0	1	AN5
0	0	1	1	0	AN6
0	0	1	1	1	AN7
0	1	0	0	0	AN8
0	1	0	0	1	AN9
0	1	0	1	0	AN10
0	1	0	1	1	AN11
0	1	1	0	0	AN12
0	1	1	0	1	AN13
0	1	1	1	0	AN14
0	1	1	1	1	AN15
1	0	0	0	0	ETRIG0 ¹
1	0	0	0	1	ETRIG1 ¹
1	0	0	1	0	ETRIG2 ¹
1	0	0	1	1	ETRIG3 ¹
1	0	1	X	X	Reserved
1	1	X	X	X	Reserved

¹ Only if ETRIG[3:0] input option is available (see device specification), else ETRISEL is ignored, that means external trigger source remains on one of the AD channels selected by ETRIGCH[3:0]

6.3.2.3 ATD Control Register 2 (ATDCTL2)

This register controls power down, interrupt and external trigger. Writes to this register will abort current conversion sequence but will not start a new sequence.

Module Base + 0x0002

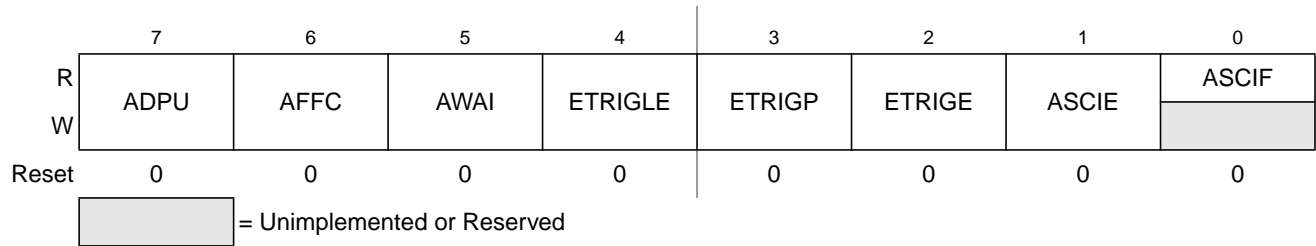

Figure 6-5. ATD Control Register 2 (ATDCTL2)

Read: Anytime

Write: Anytime

Table 6-6. ATDCTL2 Field Descriptions

Field	Description
7 ADPU	ATD Power Down — This bit provides on/off control over the ATD10B16C block allowing reduced MCU power consumption. Because analog electronic is turned off when powered down, the ATD requires a recovery time period after ADPU bit is enabled. 0 Power down ATD 1 Normal ATD functionality
6 AFFC	ATD Fast Flag Clear All 0 ATD flag clearing operates normally (read the status register ATDSTAT1 before reading the result register to clear the associate CCF flag). 1 Changes all ATD conversion complete flags to a fast clear sequence. Any access to a result register will cause the associate CCF flag to clear automatically.
5 AWAI	ATD Power Down in Wait Mode — When entering Wait Mode this bit provides on/off control over the ATD10B16C block allowing reduced MCU power. Because analog electronic is turned off when powered down, the ATD requires a recovery time period after exit from Wait mode. 0 ATD continues to run in Wait mode 1 Halt conversion and power down ATD during Wait mode After exiting Wait mode with an interrupt conversion will resume. But due to the recovery time the result of this conversion should be ignored.
4 ETRIGLE	External Trigger Level/Edge Control — This bit controls the sensitivity of the external trigger signal. See Table 6-7 for details.
3 ETRIGP	External Trigger Polarity — This bit controls the polarity of the external trigger signal. See Table 6-7 for details.
2 ETRIGE	External Trigger Mode Enable — This bit enables the external trigger on one of the AD channels or one of the ETRIG[3:0] inputs as described in Table 6-5 . If external trigger source is one of the AD channels, the digital input buffer of this channel is enabled. The external trigger allows to synchronize the start of conversion with external events. 0 Disable external trigger 1 Enable external trigger

Table 6-6. ATDCTL2 Field Descriptions (continued)

Field	Description
1 ASCIE	ATD Sequence Complete Interrupt Enable 0 ATD Sequence Complete interrupt requests are disabled. 1 ATD Interrupt will be requested whenever ASCIF = 1 is set.
0 ASCIF	ATD Sequence Complete Interrupt Flag — If ASCIE = 1 the ASCIF flag equals the SCF flag (see Section 6.3.2.7, “ATD Status Register 0 (ATDSTAT0)”), else ASCIF reads zero. Writes have no effect. 0 No ATD interrupt occurred 1 ATD sequence complete interrupt pending

Table 6-7. External Trigger Configurations

ETRIGLE	ETRIGP	External Trigger Sensitivity
0	0	Falling Edge
0	1	Ring Edge
1	0	Low Level
1	1	High Level

6.3.2.4 ATD Control Register 3 (ATDCTL3)

This register controls the conversion sequence length, FIFO for results registers and behavior in Freeze Mode. Writes to this register will abort current conversion sequence but will not start a new sequence.

Module Base + 0x0003

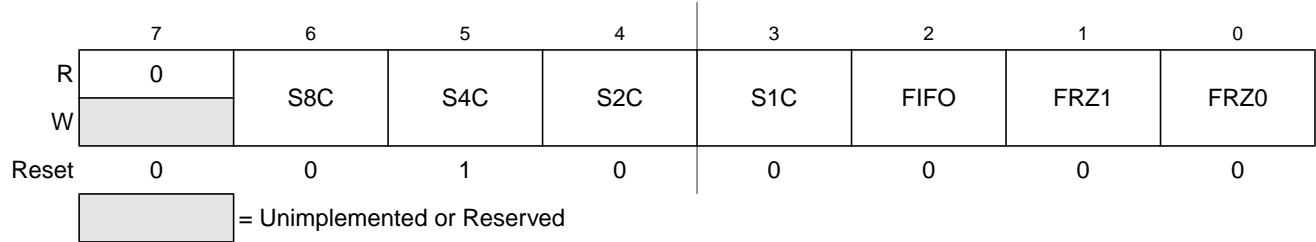

Figure 6-6. ATD Control Register 3 (ATDCTL3)

Read: Anytime

Write: Anytime

Table 6-8. ATDCTL3 Field Descriptions

Field	Description
6 S8C	Conversion Sequence Length — This bit controls the number of conversions per sequence. Table 6-9 shows all combinations. At reset, S4C is set to 1 (sequence length is 4). This is to maintain software continuity to HC12 Family.
5 S4C	Conversion Sequence Length — This bit controls the number of conversions per sequence. Table 6-9 shows all combinations. At reset, S4C is set to 1 (sequence length is 4). This is to maintain software continuity to HC12 Family.
4 S2C	Conversion Sequence Length — This bit controls the number of conversions per sequence. Table 6-9 shows all combinations. At reset, S4C is set to 1 (sequence length is 4). This is to maintain software continuity to HC12 Family.
3 S1C	Conversion Sequence Length — This bit controls the number of conversions per sequence. Table 6-9 shows all combinations. At reset, S4C is set to 1 (sequence length is 4). This is to maintain software continuity to HC12 Family.

Table 6-8. ATDCTL3 Field Descriptions (continued)

Field	Description
2 FIFO	<p>Result Register FIFO Mode —If this bit is zero (non-FIFO mode), the A/D conversion results map into the result registers based on the conversion sequence; the result of the first conversion appears in the first result register, the second result in the second result register, and so on.</p> <p>If this bit is one (FIFO mode) the conversion counter is not reset at the beginning or ending of a conversion sequence; sequential conversion results are placed in consecutive result registers. In a continuously scanning conversion sequence, the result register counter will wrap around when it reaches the end of the result register file. The conversion counter value (CC3-0 in ATDSTAT0) can be used to determine where in the result register file, the current conversion result will be placed.</p> <p>Aborting a conversion or starting a new conversion by write to an ATDCTL register (ATDCTL5-0) clears the conversion counter even if FIFO=1. So the first result of a new conversion sequence, started by writing to ATDCTL5, will always be place in the first result register (ATDDDR0). Intended usage of FIFO mode is continuous conversion (SCAN=1) or triggered conversion (ETRIG=1).</p> <p>Finally, which result registers hold valid data can be tracked using the conversion complete flags. Fast flag clear mode may or may not be useful in a particular application to track valid data.</p> <p>0 Conversion results are placed in the corresponding result register up to the selected sequence length. 1 Conversion results are placed in consecutive result registers (wrap around at end).</p>
1:0 FRZ[1:0]	<p>Background Debug Freeze Enable — When debugging an application, it is useful in many cases to have the ATD pause when a breakpoint (Freeze Mode) is encountered. These 2 bits determine how the ATD will respond to a breakpoint as shown in Table 6-10. Leakage onto the storage node and comparator reference capacitors may compromise the accuracy of an immediately frozen conversion depending on the length of the freeze period.</p>

Table 6-9. Conversion Sequence Length Coding

S8C	S4C	S2C	S1C	Number of Conversions per Sequence
0	0	0	0	16
0	0	0	1	1
0	0	1	0	2
0	0	1	1	3
0	1	0	0	4
0	1	0	1	5
0	1	1	0	6
0	1	1	1	7
1	0	0	0	8
1	0	0	1	9
1	0	1	0	10
1	0	1	1	11
1	1	0	0	12
1	1	0	1	13
1	1	1	0	14
1	1	1	1	15

Table 6-10. ATD Behavior in Freeze Mode (Breakpoint)

FRZ1	FRZ0	Behavior in Freeze Mode
0	0	Continue conversion
0	1	Reserved
1	0	Finish current conversion, then freeze
1	1	Freeze Immediately

6.3.2.5 ATD Control Register 4 (ATDCTL4)

This register selects the conversion clock frequency, the length of the second phase of the sample time and the resolution of the A/D conversion (i.e., 8-bits or 10-bits). Writes to this register will abort current conversion sequence but will not start a new sequence.

Module Base + 0x0004

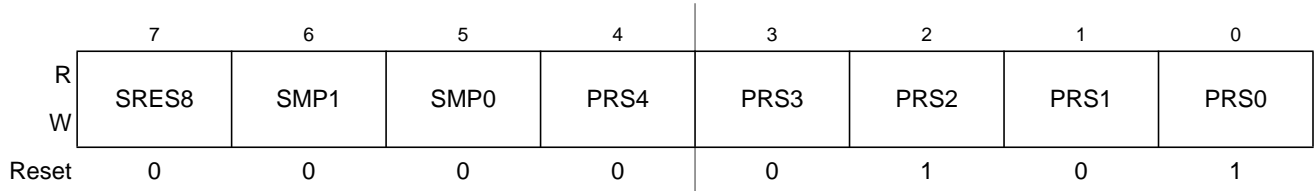

Figure 6-7. ATD Control Register 4 (ATDCTL4)

Read: Anytime

Write: Anytime

Table 6-11. ATDCTL4 Field Descriptions

Field	Description
7 SRES8	<p>A/D Resolution Select — This bit selects the resolution of A/D conversion results as either 8 or 10 bits. The A/D converter has an accuracy of 10 bits. However, if low resolution is required, the conversion can be speeded up by selecting 8-bit resolution.</p> <p>0 10 bit resolution 1 8 bit resolution</p>
6:5 SMP[1:0]	<p>Sample Time Select — These two bits select the length of the second phase of the sample time in units of ATD conversion clock cycles. Note that the ATD conversion clock period is itself a function of the prescaler value (bits PRS4-0). The sample time consists of two phases. The first phase is two ATD conversion clock cycles long and transfers the sample quickly (via the buffer amplifier) onto the A/D machine's storage node. The second phase attaches the external analog signal directly to the storage node for final charging and high accuracy. Table 6-12 lists the lengths available for the second sample phase.</p>
4:0 PRS[4:0]	<p>ATD Clock Prescaler — These 5 bits are the binary value prescaler value PRS. The ATD conversion clock frequency is calculated as follows:</p> $ATDclock = \frac{[BusClock]}{[PRS + 1]} \cdot 0.5$ <p>Note: The maximum ATD conversion clock frequency is half the bus clock. The default (after reset) prescaler value is 5 which results in a default ATD conversion clock frequency that is bus clock divided by 12. Table 6-13 illustrates the divide-by operation and the appropriate range of the bus clock.</p>

Table 6-12. Sample Time Select

SMP1	SMP0	Length of 2nd Phase of Sample Time
0	0	2 A/D conversion clock periods
0	1	4 A/D conversion clock periods
1	0	8 A/D conversion clock periods
1	1	16 A/D conversion clock periods

Table 6-13. Clock Prescaler Values

Prescale Value	Total Divisor Value	Max. Bus Clock ¹	Min. Bus Clock ²
00000	Divide by 2	4 MHz	1 MHz
00001	Divide by 4	8 MHz	2 MHz
00010	Divide by 6	12 MHz	3 MHz
00011	Divide by 8	16 MHz	4 MHz
00100	Divide by 10	20 MHz	5 MHz
00101	Divide by 12	24 MHz	6 MHz
00110	Divide by 14	28 MHz	7 MHz
00111	Divide by 16	32 MHz	8 MHz
01000	Divide by 18	36 MHz	9 MHz
01001	Divide by 20	40 MHz	10 MHz
01010	Divide by 22	44 MHz	11 MHz
01011	Divide by 24	48 MHz	12 MHz
01100	Divide by 26	52 MHz	13 MHz
01101	Divide by 28	56 MHz	14 MHz
01110	Divide by 30	60 MHz	15 MHz
01111	Divide by 32	64 MHz	16 MHz
10000	Divide by 34	68 MHz	17 MHz
10001	Divide by 36	72 MHz	18 MHz
10010	Divide by 38	76 MHz	19 MHz
10011	Divide by 40	80 MHz	20 MHz
10100	Divide by 42	84 MHz	21 MHz
10101	Divide by 44	88 MHz	22 MHz
10110	Divide by 46	92 MHz	23 MHz
10111	Divide by 48	96 MHz	24 MHz
11000	Divide by 50	100 MHz	25 MHz
11001	Divide by 52	104 MHz	26 MHz
11010	Divide by 54	108 MHz	27 MHz
11011	Divide by 56	112 MHz	28 MHz
11100	Divide by 58	116 MHz	29 MHz
11101	Divide by 60	120 MHz	30 MHz
11110	Divide by 62	124 MHz	31 MHz
11111	Divide by 64	128 MHz	32 MHz

¹ Maximum ATD conversion clock frequency is 2 MHz. The maximum allowed bus clock frequency is shown in this column.

² Minimum ATD conversion clock frequency is 500 kHz. The minimum allowed bus clock frequency is shown in this column.

6.3.2.6 ATD Control Register 5 (ATDCTL5)

This register selects the type of conversion sequence and the analog input channels sampled. Writes to this register will abort current conversion sequence and start a new conversion sequence. If external trigger is enabled (ETRIGE = 1) an initial write to ATDCTL5 is required to allow starting of a conversion sequence which will then occur on each trigger event. Start of conversion means the beginning of the sampling phase.

Module Base + 0x0005

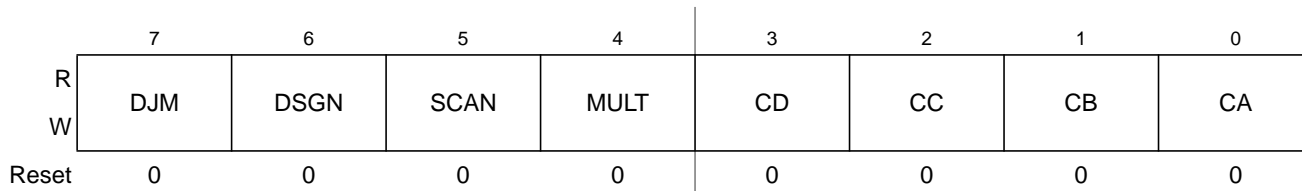

Figure 6-8. ATD Control Register 5 (ATDCTL5)

Read: Anytime

Write: Anytime

Table 6-14. ATDCTL5 Field Descriptions

Field	Description
7 DJM	<p>Result Register Data Justification — This bit controls justification of conversion data in the result registers. See Section 6.3.2.16, “ATD Conversion Result Registers (ATDDRx)” for details.</p> <p>0 Left justified data in the result registers. 1 Right justified data in the result registers.</p>
6 DSGN	<p>Result Register Data Signed or Unsigned Representation — This bit selects between signed and unsigned conversion data representation in the result registers. Signed data is represented as 2’s complement. Signed data is not available in right justification. See 6.3.2.16 ATD Conversion Result Registers (ATDDRx) for details.</p> <p>0 Unsigned data representation in the result registers. 1 Signed data representation in the result registers.</p> <p>Table 6-15 summarizes the result data formats available and how they are set up using the control bits. Table 6-16 illustrates the difference between the signed and unsigned, left justified output codes for an input signal range between 0 and 5.12 Volts.</p>
5 SCAN	<p>Continuous Conversion Sequence Mode — This bit selects whether conversion sequences are performed continuously or only once. If external trigger is enabled (ETRIGE=1) setting this bit has no effect, that means each trigger event starts a single conversion sequence.</p> <p>0 Single conversion sequence 1 Continuous conversion sequences (scan mode)</p>
4 MULT	<p>Multi-Channel Sample Mode — When MULT is 0, the ATD sequence controller samples only from the specified analog input channel for an entire conversion sequence. The analog channel is selected by channel selection code (control bits CD/CC/CB/CA located in ATDCTL5). When MULT is 1, the ATD sequence controller samples across channels. The number of channels sampled is determined by the sequence length value (S8C, S4C, S2C, S1C). The first analog channel examined is determined by channel selection code (CC, CB, CA control bits); subsequent channels sampled in the sequence are determined by incrementing the channel selection code or wrapping around to AN0 (channel 0).</p> <p>0 Sample only one channel 1 Sample across several channels</p>

Table 6-14. ATDCTL5 Field Descriptions (continued)

Field	Description
3:0 C{D:A}	<p>Analog Input Channel Select Code — These bits select the analog input channel(s) whose signals are sampled and converted to digital codes. Table 6-17 lists the coding used to select the various analog input channels.</p> <p>In the case of single channel conversions (MULT = 0), this selection code specified the channel to be examined. In the case of multiple channel conversions (MULT = 1), this selection code represents the first channel to be examined in the conversion sequence. Subsequent channels are determined by incrementing the channel selection code or wrapping around to AN0 (after converting the channel defined by the Wrap Around Channel Select Bits WRAP[3:0] in ATDCTL0). In case starting with a channel number higher than the one defined by WRAP[3:0] the first wrap around will be AN15 to AN0.</p>

Table 6-15. Available Result Data Formats.

SRES8	DJM	DSGN	Result Data Formats Description and Bus Bit Mapping
1	0	0	8-bit / left justified / unsigned — bits 15:8
1	0	1	8-bit / left justified / signed — bits 15:8
1	1	X	8-bit / right justified / unsigned — bits 7:0
0	0	0	10-bit / left justified / unsigned — bits 15:6
0	0	1	10-bit / left justified / signed — bits 15:6
0	1	X	10-bit / right justified / unsigned — bits 9:0

Table 6-16. Left Justified, Signed and Unsigned ATD Output Codes.

Input Signal $V_{RL} = 0$ Volts $V_{RH} = 5.12$ Volts	Signed 8-Bit Codes	Unsigned 8-Bit Codes	Signed 10-Bit Codes	Unsigned 10-Bit Codes
5.120 Volts	7F	FF	7FC0	FFC0
5.100	7F	FF	7F00	FF00
5.080	7E	FE	7E00	FE00
2.580	01	81	0100	8100
2.560	00	80	0000	8000
2.540	FF	7F	FF00	7F00
0.020	81	01	8100	0100
0.000	80	00	8000	0000

Table 6-17. Analog Input Channel Select Coding

CD	CC	CB	CA	Analog Input Channel
0	0	0	0	AN0
0	0	0	1	AN1
0	0	1	0	AN2
0	0	1	1	AN3
0	1	0	0	AN4
0	1	0	1	AN5
0	1	1	0	AN6
0	1	1	1	AN7
1	0	0	0	AN8
1	0	0	1	AN9
1	0	1	0	AN10
1	0	1	1	AN11
1	1	0	0	AN12
1	1	0	1	AN13
1	1	1	0	AN14
1	1	1	1	AN15

6.3.2.7 ATD Status Register 0 (ATDSTAT0)

This read-only register contains the Sequence Complete Flag, overrun flags for external trigger and FIFO mode, and the conversion counter.

Module Base + 0x0006

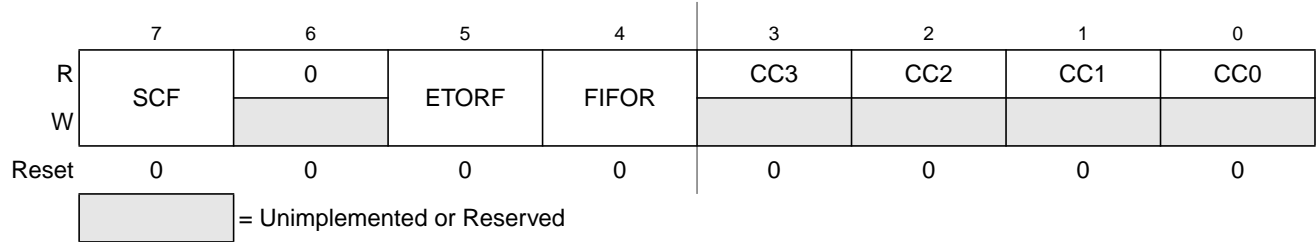

Figure 6-9. ATD Status Register 0 (ATDSTAT0)

Read: Anytime

Write: Anytime (No effect on CC[3:0])

Table 6-18. ATDSTAT0 Field Descriptions

Field	Description
7 SCF	<p>Sequence Complete Flag — This flag is set upon completion of a conversion sequence. If conversion sequences are continuously performed (SCAN = 1), the flag is set after each one is completed. This flag is cleared when one of the following occurs:</p> <ul style="list-style-type: none"> • Write “1” to SCF • Write to ATDCTL5 (a new conversion sequence is started) • If AFFC = 1 and read of a result register <p>0 Conversion sequence not completed 1 Conversion sequence has completed</p>
5 ETORF	<p>External Trigger Overrun Flag —While in edge trigger mode (ETRIGLE = 0), if additional active edges are detected while a conversion sequence is in process the overrun flag is set. This flag is cleared when one of the following occurs:</p> <ul style="list-style-type: none"> • Write “1” to ETORF • Write to ATDCTL0,1,2,3,4 (a conversion sequence is aborted) • Write to ATDCTL5 (a new conversion sequence is started) <p>0 No External trigger over run error has occurred 1 External trigger over run error has occurred</p>

Table 6-18. ATDSTAT0 Field Descriptions (continued)

Field	Description
<p>4 FIFOR</p>	<p>FIFO Over Run Flag — This bit indicates that a result register has been written to before its associated conversion complete flag (CCF) has been cleared. This flag is most useful when using the FIFO mode because the flag potentially indicates that result registers are out of sync with the input channels. However, it is also practical for non-FIFO modes, and indicates that a result register has been over written before it has been read (i.e., the old data has been lost). This flag is cleared when one of the following occurs:</p> <ul style="list-style-type: none"> • Write “1” to FIFOR • Start a new conversion sequence (write to ATDCTL5 or external trigger) <p>0 No over run has occurred 1 Overrun condition exists (result register has been written while associated CCFx flag remained set)</p>
<p>3:0 CC{3:0}</p>	<p>Conversion Counter — These 4 read-only bits are the binary value of the conversion counter. The conversion counter points to the result register that will receive the result of the current conversion. For example, CC3 = 0, CC2 = 1, CC1 = 1, CC0 = 0 indicates that the result of the current conversion will be in ATD Result Register 6. If in non-FIFO mode (FIFO = 0) the conversion counter is initialized to zero at the begin and end of the conversion sequence. If in FIFO mode (FIFO = 1) the register counter is not initialized. The conversion counters wraps around when its maximum value is reached.</p> <p>Aborting a conversion or starting a new conversion by write to an ATDCTL register (ATDCTL5-0) clears the conversion counter even if FIFO=1.</p>

6.3.2.8 Reserved Register 0 (ATDTEST0)

Module Base + 0x0008

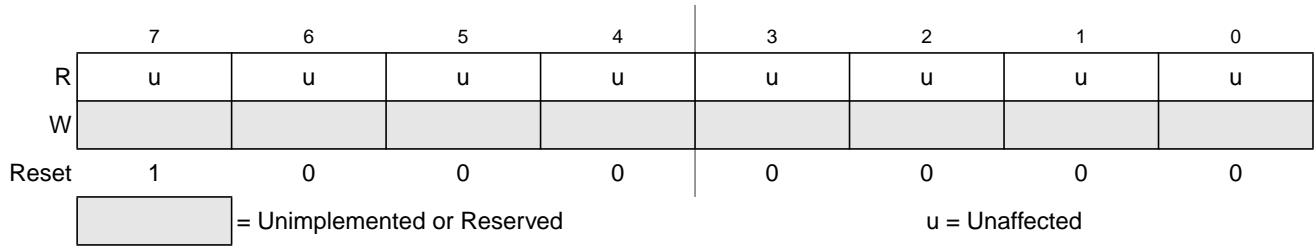

Figure 6-10. Reserved Register 0 (ATDTEST0)

Read: Anytime, returns unpredictable values

Write: Anytime in special modes, unimplemented in normal modes

NOTE

Writing to this register when in special modes can alter functionality.

6.3.2.9 ATD Test Register 1 (ATDTEST1)

This register contains the SC bit used to enable special channel conversions.

Module Base + 0x0009

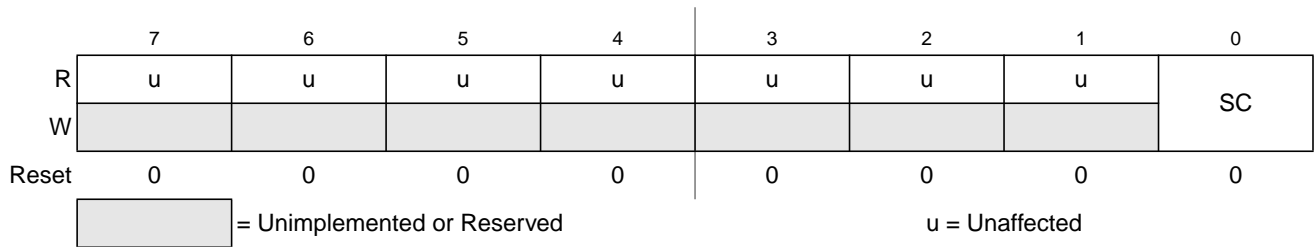

Figure 6-11. Reserved Register 1 (ATDTEST1)

Read: Anytime, returns unpredictable values for bit 7 and bit 6

Write: Anytime

NOTE

Writing to this register when in special modes can alter functionality.

Table 6-19. ATDTEST1 Field Descriptions

Field	Description
0 SC	Special Channel Conversion Bit — If this bit is set, then special channel conversion can be selected using CC, CB, and CA of ATDCTL5. Table 6-20 lists the coding. 0 Special channel conversions disabled 1 Special channel conversions enabled

Table 6-20. Special Channel Select Coding

SC	CD	CC	CB	CA	Analog Input Channel
1	0	0	X	X	Reserved
1	0	1	0	0	V _{RH}
1	0	1	0	1	V _{RL}
1	0	1	1	0	(V _{RH} +V _{RL}) / 2
1	0	1	1	1	Reserved
1	1	X	X	X	Reserved

6.3.2.10 ATD Status Register 2 (ATDSTAT2)

This read-only register contains the Conversion Complete Flags CCF15 to CCF8.

Module Base + 0x000A

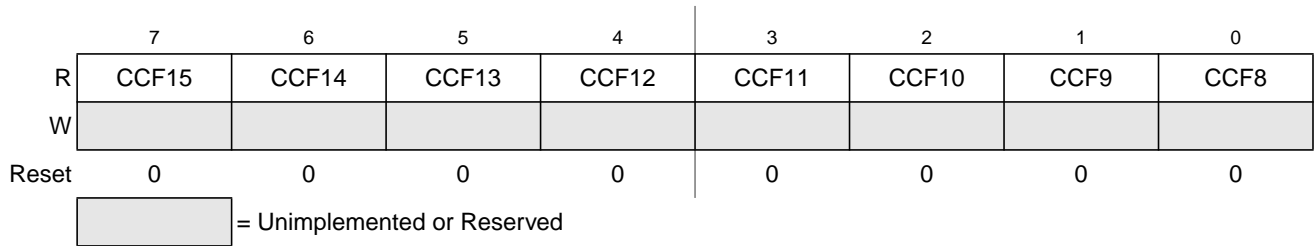

Figure 6-12. ATD Status Register 2 (ATDSTAT2)

Read: Anytime

Write: Anytime, no effect

Table 6-21. ATDSTAT2 Field Descriptions

Field	Description
7:0 CCF[15:8]	<p>Conversion Complete Flag Bits — A conversion complete flag is set at the end of each conversion in a conversion sequence. The flags are associated with the conversion position in a sequence (and also the result register number). Therefore, CCF8 is set when the ninth conversion in a sequence is complete and the result is available in result register ATDDR8; CCF9 is set when the tenth conversion in a sequence is complete and the result is available in ATDDR9, and so forth. A flag CCFx (x = 15, 14, 13, 12, 11, 10, 9, 8) is cleared when one of the following occurs:</p> <ul style="list-style-type: none"> • Write to ATDCTL5 (a new conversion sequence is started) • If AFFC = 0 and read of ATDSTAT2 followed by read of result register ATDDRx • If AFFC = 1 and read of result register ATDDRx <p>In case of a concurrent set and clear on CCFx: The clearing by method A) will overwrite the set. The clearing by methods B) or C) will be overwritten by the set.</p> <p>0 Conversion number x not completed 1 Conversion number x has completed, result ready in ATDDRx</p>

6.3.2.11 ATD Status Register 1 (ATDSTAT1)

This read-only register contains the Conversion Complete Flags CCF7 to CCF0

Module Base + 0x000B

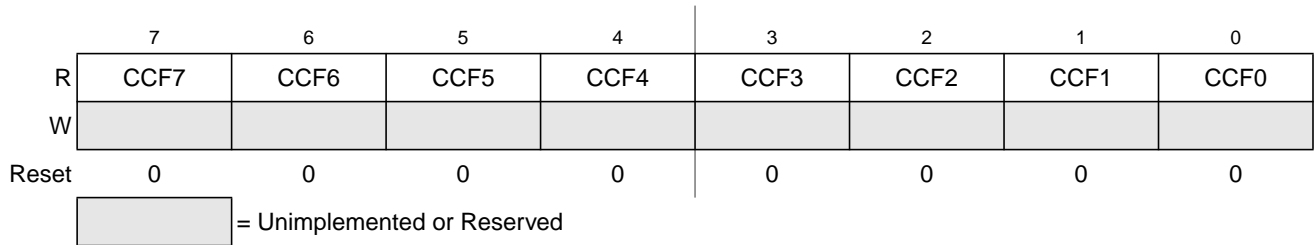

Figure 6-13. ATD Status Register 1 (ATDSTAT1)

Read: Anytime

Write: Anytime, no effect

Table 6-22. ATDSTAT1 Field Descriptions

Field	Description
7:0 CCF[7:0]	<p>Conversion Complete Flag Bits — A conversion complete flag is set at the end of each conversion in a conversion sequence. The flags are associated with the conversion position in a sequence (and also the result register number). Therefore, CCF0 is set when the first conversion in a sequence is complete and the result is available in result register ATDDR0; CCF1 is set when the second conversion in a sequence is complete and the result is available in ATDDR1, and so forth. A CCF flag is cleared when one of the following occurs:</p> <ul style="list-style-type: none"> • Write to ATDCTL5 (a new conversion sequence is started) • If AFFC = 0 and read of ATDSTAT1 followed by read of result register ATDDR_x • If AFFC = 1 and read of result register ATDDR_x <p>In case of a concurrent set and clear on CCF_x: The clearing by method A) will overwrite the set. The clearing by methods B) or C) will be overwritten by the set.</p> <p>Conversion number x not completed Conversion number x has completed, result ready in ATDDR_x</p>

6.3.2.12 ATD Input Enable Register 0 (ATDDIEN0)

Module Base + 0x000C

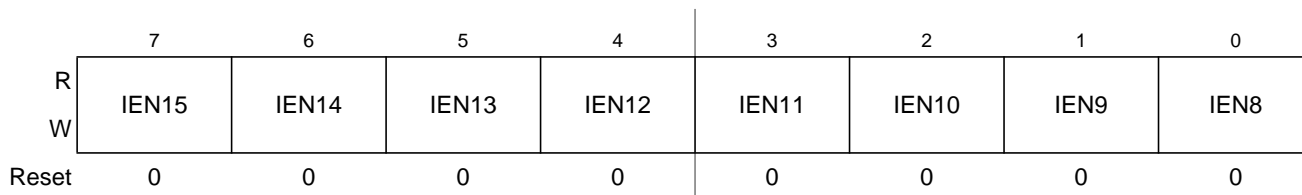

Figure 6-14. ATD Input Enable Register 0 (ATDDIEN0)

Read: Anytime

Write: anytime

Table 6-23. ATDDIEN0 Field Descriptions

Field	Description
7:0 IEN[15:8]	<p>ATD Digital Input Enable on Channel Bits — This bit controls the digital input buffer from the analog input pin (ANx) to PTADx data register.</p> <p>0 Disable digital input buffer to PTADx 1 Enable digital input buffer to PTADx.</p> <p>Note: Setting this bit will enable the corresponding digital input buffer continuously. If this bit is set while simultaneously using it as an analog port, there is potentially increased power consumption because the digital input buffer maybe in the linear region.</p>

6.3.2.13 ATD Input Enable Register 1 (ATDDIEN1)

Module Base + 0x000D

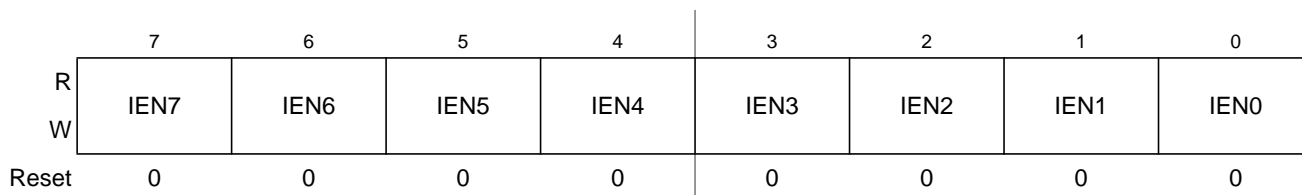

Figure 6-15. ATD Input Enable Register 1 (ATDDIEN1)

Read: Anytime

Write: Anytime

Table 6-24. ATDDIEN1 Field Descriptions

Field	Description
7:0 IEN[7:0]	<p>ATD Digital Input Enable on Channel Bits — This bit controls the digital input buffer from the analog input pin (ANx) to PTADx data register.</p> <p>0 Disable digital input buffer to PTADx 1 Enable digital input buffer to PTADx.</p> <p>Note: Setting this bit will enable the corresponding digital input buffer continuously. If this bit is set while simultaneously using it as an analog port, there is potentially increased power consumption because the digital input buffer maybe in the linear region.</p>

6.3.2.14 Port Data Register 0 (PORTAD0)

The data port associated with the ATD is input-only. The port pins are shared with the analog A/D inputs AN[15:8].

Module Base + 0x000E

	7	6	5	4	3	2	1	0
R	PTAD15	PTAD14	PTAD13	PTAD12	PTAD11	PTAD10	PTAD9	PTAD8
W								
Reset	1	1	1	1	1	1	1	1
Pin Function	AN15	AN14	AN13	AN12	AN11	AN10	AN9	AN8

 = Unimplemented or Reserved

Figure 6-16. Port Data Register 0 (PORTAD0)

Read: Anytime

Write: Anytime, no effect

The A/D input channels may be used for general-purpose digital input.

Table 6-25. PORTAD0 Field Descriptions

Field	Description
7:0 PTAD[15:8]	<p>A/D Channel x (ANx) Digital Input Bits— If the digital input buffer on the ANx pin is enabled (IENx = 1) or channel x is enabled as external trigger (ETRIGE = 1, ETRIGCH[3-0] = x, ETRIGSEL = 0) read returns the logic level on ANx pin (signal potentials not meeting V_{IL} or V_{IH} specifications will have an indeterminate value). If the digital input buffers are disabled (IENx = 0) and channel x is not enabled as external trigger, read returns a “1”.</p> <p>Reset sets all PORTAD0 bits to “1”.</p>

6.3.2.15 Port Data Register 1 (PORTAD1)

The data port associated with the ATD is input-only. The port pins are shared with the analog A/D inputs AN7-0.

Module Base + 0x000F

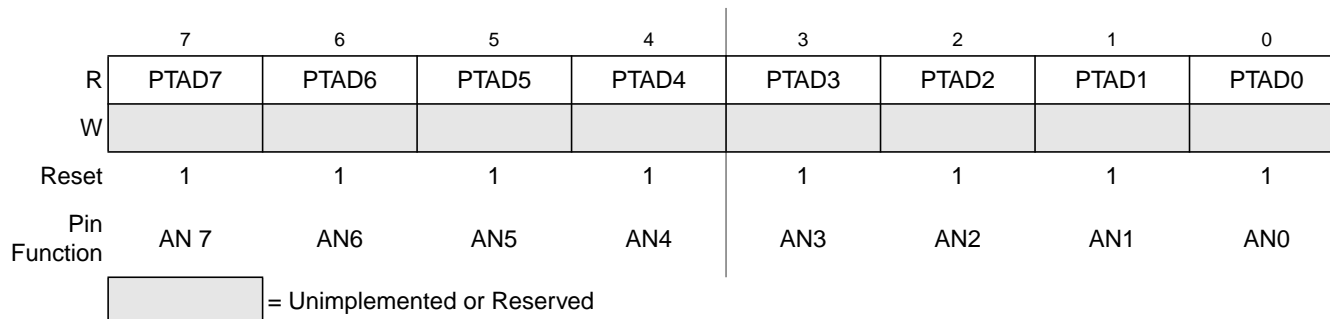

Figure 6-17. Port Data Register 1 (PORTAD1)

Read: Anytime

Write: Anytime, no effect

The A/D input channels may be used for general-purpose digital input.

Table 6-26. PORTAD1 Field Descriptions

Field	Description
7:0 PTAD[7:8]	A/D Channel x (ANx) Digital Input Bits — If the digital input buffer on the ANx pin is enabled (IENx=1) or channel x is enabled as external trigger (ETRIGE = 1, ETRIGCH[3-0] = x, ETRIGSEL = 0) read returns the logic level on ANx pin (signal potentials not meeting V _{IL} or V _{IH} specifications will have an indeterminate value). If the digital input buffers are disabled (IENx = 0) and channel x is not enabled as external trigger, read returns a “1”. Reset sets all PORTAD1 bits to “1”.

6.3.2.16 ATD Conversion Result Registers (ATDDR_x)

The A/D conversion results are stored in 16 read-only result registers. The result data is formatted in the result registers based on two criteria. First there is left and right justification; this selection is made using the DJM control bit in ATDCTL5. Second there is signed and unsigned data; this selection is made using the DSGN control bit in ATDCTL5. Signed data is stored in 2's complement format and only exists in left justified format. Signed data selected for right justified format is ignored.

Read: Anytime

Write: Anytime in special mode, unimplemented in normal modes

6.3.2.16.1 Left Justified Result Data

Module Base +	0x0010 = ATDDR0H	0x0018 = ATDDR4H	0x0020 = ATDDR8H	0x0028 = ATDDR12H
	0x0012 = ATDDR1H	0x001A = ATDDR5H	0x0022 = ATDDR9H	0x002A = ATDDR13H
	0x0014 = ATDDR2H	0x001C = ATDDR6H	0x0024 = ATDDR10H	0x002C = ATDDR14H
	0x0016 = ATDDR3H	0x001E = ATDDR7H	0x0026 = ATDDR11H	0x002E = ATDDR15H

	7	6	5	4	3	2	1	0
R (10-BIT)	BIT 9 MSB	BIT 8	BIT 7	BIT 6	BIT 5	BIT 4	BIT 3	BIT 2
R (8-BIT)	BIT 7 MSB	BIT 6	BIT 5	BIT 4	BIT 3	BIT 2	BIT 1	BIT 0
W								
Reset	0	0	0	0	0	0	0	0

= Unimplemented or Reserved

Figure 6-18. Left Justified, ATD Conversion Result Register x, High Byte (ATDDR_xH)

Module Base +	0x0011 = ATDDR0L	0x0019 = ATDDR4L	0x0021 = ATDDR8L	0x0029 = ATDDR12L
	0x0013 = ATDDR1L	0x001B = ATDDR5L	0x0023 = ATDDR9L	0x002B = ATDDR13L
	0x0015 = ATDDR2L	0x001D = ATDDR6L	0x0025 = ATDDR10L	0x002D = ATDDR14L
	0x0017 = ATDDR3L	0x001F = ATDDR7L	0x0027 = ATDDR11L	0x002F = ATDDR15L

	7	6	5	4	3	2	1	0
R (10-BIT)	BIT 1	BIT 0	0	0	0	0	0	0
R (8-BIT)	u	u	0	0	0	0	0	0
W								
Reset	0	0	0	0	0	0	0	0

= Unimplemented or Reserved

u = Unaffected

Figure 6-19. Left Justified, ATD Conversion Result Register x, Low Byte (ATDDR_xL)

6.3.2.16.2 Right Justified Result Data

Module Base + 0x0010 = ATDDR0H, 0x0018 = ATDDR4H, 0x0020 = ATDDR8H, 0x0028 = ATDDR12H,
 0x0012 = ATDDR1H, 0x001A = ATDDR5H, 0x0022 = ATDDR9H, 0x002A = ATDDR13H,
 0x0014 = ATDDR2H, 0x001C = ATDDR6H, 0x0024 = ATDDR10H, 0x002C = ATDDR14H,
 0x0016 = ATDDR3H 0x001E = ATDDR7H 0x0026 = ATDDR11H 0x002E = ATDDR15H

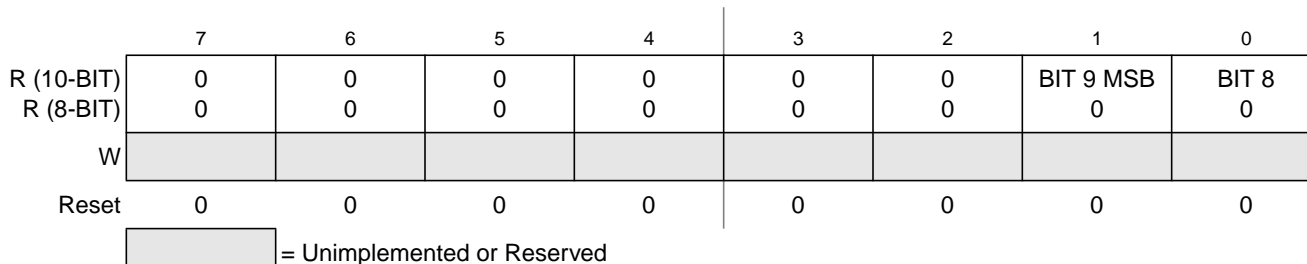

Figure 6-20. Right Justified, ATD Conversion Result Register x, High Byte (ATDDRxH)

Module Base + 0x0011 = ATDDR0L, 0x0019 = ATDDR4L, 0x0021 = ATDDR8L, 0x0029 = ATDDR12L,
 0x0013 = ATDDR1L, 0x001B = ATDDR5L, 0x0023 = ATDDR9L, 0x002B = ATDDR13L,
 0x0015 = ATDDR2L, 0x001D = ATDDR6L, 0x0025 = ATDDR10L, 0x002D = ATDDR14L,
 0x0017 = ATDDR3L 0x001F = ATDDR7L 0x0027 = ATDDR11L 0x002F = ATDDR15L

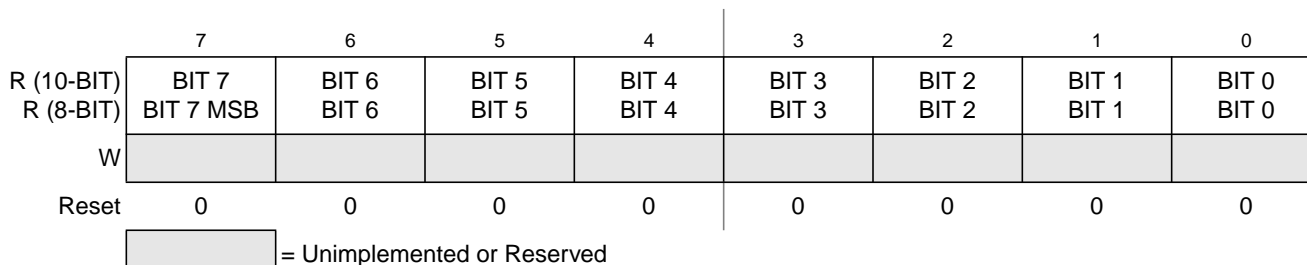

Figure 6-21. Right Justified, ATD Conversion Result Register x, Low Byte (ATDDRxL)

6.4 Functional Description

The ATD10B16C is structured in an analog and a digital sub-block.

6.4.1 Analog Sub-block

The analog sub-block contains all analog electronics required to perform a single conversion. Separate power supplies V_{DDA} and V_{SSA} allow to isolate noise of other MCU circuitry from the analog sub-block.

6.4.1.1 Sample and Hold Machine

The sample and hold (S/H) machine accepts analog signals from the external world and stores them as capacitor charge on a storage node.

The sample process uses a two stage approach. During the first stage, the sample amplifier is used to quickly charge the storage node. The second stage connects the input directly to the storage node to complete the sample for high accuracy.

When not sampling, the sample and hold machine disables its own clocks. The analog electronics continue drawing their quiescent current. The power down (ADPU) bit must be set to disable both the digital clocks and the analog power consumption.

The input analog signals are unipolar and must fall within the potential range of V_{SSA} to V_{DDA} .

6.4.1.2 Analog Input Multiplexer

The analog input multiplexer connects one of the 16 external analog input channels to the sample and hold machine.

6.4.1.3 Sample Buffer Amplifier

The sample amplifier is used to buffer the input analog signal so that the storage node can be quickly charged to the sample potential.

6.4.1.4 Analog-to-Digital (A/D) Machine

The A/D machine performs analog to digital conversions. The resolution is program selectable at either 8 or 10 bits. The A/D machine uses a successive approximation architecture. It functions by comparing the stored analog sample potential with a series of digitally generated analog potentials. By following a binary search algorithm, the A/D machine locates the approximating potential that is nearest to the sampled potential.

When not converting the A/D machine disables its own clocks. The analog electronics continue drawing quiescent current. The power down (ADPU) bit must be set to disable both the digital clocks and the analog power consumption.

Only analog input signals within the potential range of V_{RL} to V_{RH} (A/D reference potentials) will result in a non-railed digital output codes.

6.4.2 Digital Sub-Block

This subsection explains some of the digital features in more detail. See register descriptions for all details.

6.4.2.1 External Trigger Input

The external trigger feature allows the user to synchronize ATD conversions to the external environment events rather than relying on software to signal the ATD module when ATD conversions are to take place. The external trigger signal (out of reset ATD channel 15, configurable in ATDCTL1) is programmable to be edge or level sensitive with polarity control. [Table 6-27](#) gives a brief description of the different combinations of control bits and their effect on the external trigger function.

Table 6-27. External Trigger Control Bits

ETRIGLE	ETRIGP	ETRIGE	SCAN	Description
X	X	0	0	Ignores external trigger. Performs one conversion sequence and stops.
X	X	0	1	Ignores external trigger. Performs continuous conversion sequences.
0	0	1	X	Falling edge triggered. Performs one conversion sequence per trigger.
0	1	1	X	Rising edge triggered. Performs one conversion sequence per trigger.
1	0	1	X	Trigger active low. Performs continuous conversions while trigger is active.
1	1	1	X	Trigger active high. Performs continuous conversions while trigger is active.

During a conversion, if additional active edges are detected the overrun error flag ETORF is set.

In either level or edge triggered modes, the first conversion begins when the trigger is received. In both cases, the maximum latency time is one bus clock cycle plus any skew or delay introduced by the trigger circuitry.

After ETRIGE is enabled, conversions cannot be started by a write to ATDCTL5, but rather must be triggered externally.

If the level mode is active and the external trigger both de-asserts and re-asserts itself during a conversion sequence, this does not constitute an overrun. Therefore, the flag is not set. If the trigger remains asserted in level mode while a sequence is completing, another sequence will be triggered immediately.

6.4.2.2 General-Purpose Digital Input Port Operation

The input channel pins can be multiplexed between analog and digital data. As analog inputs, they are multiplexed and sampled to supply signals to the A/D converter. As digital inputs, they supply external input data that can be accessed through the digital port registers (PORTAD0 & PORTAD1) (input-only).

The analog/digital multiplex operation is performed in the input pads. The input pad is always connected to the analog inputs of the ATD10B16C. The input pad signal is buffered to the digital port registers. This buffer can be turned on or off with the ATDDIEN0 & ATDDIEN1 register. This is important so that the buffer does not draw excess current when analog potentials are presented at its input.

6.4.3 Operation in Low Power Modes

The ATD10B16C can be configured for lower MCU power consumption in three different ways:

- Stop Mode**
 Stop Mode: This halts A/D conversion. Exit from Stop mode will resume A/D conversion, But due to the recovery time the result of this conversion should be ignored.

 Entering stop mode causes all clocks to halt and thus the system is placed in a minimum power standby mode. This halts any conversion sequence in progress. During recovery from stop mode, there must be a minimum delay for the stop recovery time t_{SR} before initiating a new ATD conversion sequence.
- Wait Mode**
 Wait Mode with AWAI = 1: This halts A/D conversion. Exit from Wait mode will resume A/D conversion, but due to the recovery time the result of this conversion should be ignored.

Entering wait mode, the ATD conversion either continues or halts for low power depending on the logical value of the AWAITS bit.

- **Freeze Mode**

Writing ADPU = 0 (Note that all ATD registers remain accessible.): This aborts any A/D conversion in progress.

In freeze mode, the ATD10B16C will behave according to the logical values of the FRZ1 and FRZ0 bits. This is useful for debugging and emulation.

NOTE

The reset value for the ADPU bit is zero. Therefore, when this module is reset, it is reset into the power down state.

6.5 Initialization/Application Information

6.5.1 Setting up and starting an A/D conversion

The following describes a typical setup procedure for starting A/D conversions. It is highly recommended to follow this procedure to avoid common mistakes.

Each step of the procedure will have a general remark and a typical example

6.5.1.1 Step 1

Power up the ATD and concurrently define other settings in ATDCTL2

Example: Write to ATDCTL2: ADPU=1 -> powers up the ATD, ASCIE=1 enable interrupt on finish of a conversion sequence.

6.5.1.2 Step 2

Wait for the ATD Recovery Time t_{REC} before you proceed with Step 3.

Example: Use the CPU in a branch loop to wait for a defined number of bus clocks.

6.5.1.3 Step 3

Configure how many conversions you want to perform in one sequence and define other settings in ATDCTL3.

Example: Write S4C=1 to do 4 conversions per sequence.

6.5.1.4 Step 4

Configure resolution, sampling time and ATD clock speed in ATDCTL4.

Example: Use default for resolution and sampling time by leaving SRES8, SMP1 and SMP0 clear. For a bus clock of 40MHz write 9 to PR4-0, this gives an ATD clock of $0.5 \cdot 40\text{MHz} / (9+1) = 2\text{MHz}$ which is within the allowed range for f_{ATDCLK} .

6.5.1.5 Step 5

Configure starting channel, single/multiple channel, continuous or single sequence and result data format in ATDCTL5. Writing ATDCTL5 will start the conversion, so make sure you write ATDCTL5 in the last step.

Example: Leave CD, CC,CB,CA clear to start on channel AN0. Write MULT=1 to convert channel AN0 to AN3 in a sequence (4 conversion per sequence selected in ATDCTL3).

6.5.2 Aborting an A/D conversion

6.5.2.1 Step 1

Write to ATDCTL4. This will abort any ongoing conversion sequence.

(Do not use write to other ATDCTL registers to abort, as this under certain circumstances might not work correctly.)

6.5.2.2 Step 2

Disable the ATD Interrupt by writing ASCIE=0 in ATDCTL2.

It is important to clear the interrupt enable at this point, prior to step 3, as depending on the device clock gating it may not always be possible to clear it or the SCF flag once the module is disabled (ADPU=0).

6.5.2.3 Step 3

Clear the SCF flag by writing a 1 in ATDSTAT0.

(Remaining flags will be cleared with the next start of a conversions, but SCF flag should be cleared to avoid SCF interrupt.)

6.5.2.4 Step 4

Power down ATD by writing ADPU=0 in ATDCTL2.

6.6 Resets

At reset the ATD10B16C is in a power down state. The reset state of each individual bit is listed within [Section 6.3, “Memory Map and Register Definition,”](#) which details the registers and their bit fields.

6.7 Interrupts

The interrupt requested by the ATD10B16C is listed in [Table 6-28](#). Refer to MCU specification for related vector address and priority.

Table 6-28. ATD Interrupt Vectors

Interrupt Source	CCR Mask	Local Enable
Sequence Complete Interrupt	I bit	ASCIE in ATDCTL2

See [Section 6.3.2, “Register Descriptions,”](#) for further details.

Chapter 7

Digital-to-Analog Converter (DAC8B1CV1) Block Description

7.1 Introduction

The DAC8B1C is a 8-bit, 1-channel digital-to-analog converter module.

7.1.1 Features

The DAC8B1C includes these features:

- 8-bit resolution.
- One output independent monotonic channel.

7.1.2 Modes of Operation

The DAC8B1C functions the same in normal, special, and emulation modes. It has two low-power modes, wait and stop modes.

7.1.2.1 Run Mode

Normal mode of operation.

7.1.2.2 Wait Mode

Entering wait mode, the DAC conversion either continues or aborts for low power, depending on the logical state of the DACWAI bit.

7.1.2.3 Stop Mode

The DAC8B1C module is disabled in stop mode for reduced power consumption. The STOP instruction does not affect DAC register states.

7.1.3 Block Diagram

[Figure 7-1](#) illustrates the functional block diagram of the DAC8B1C module.

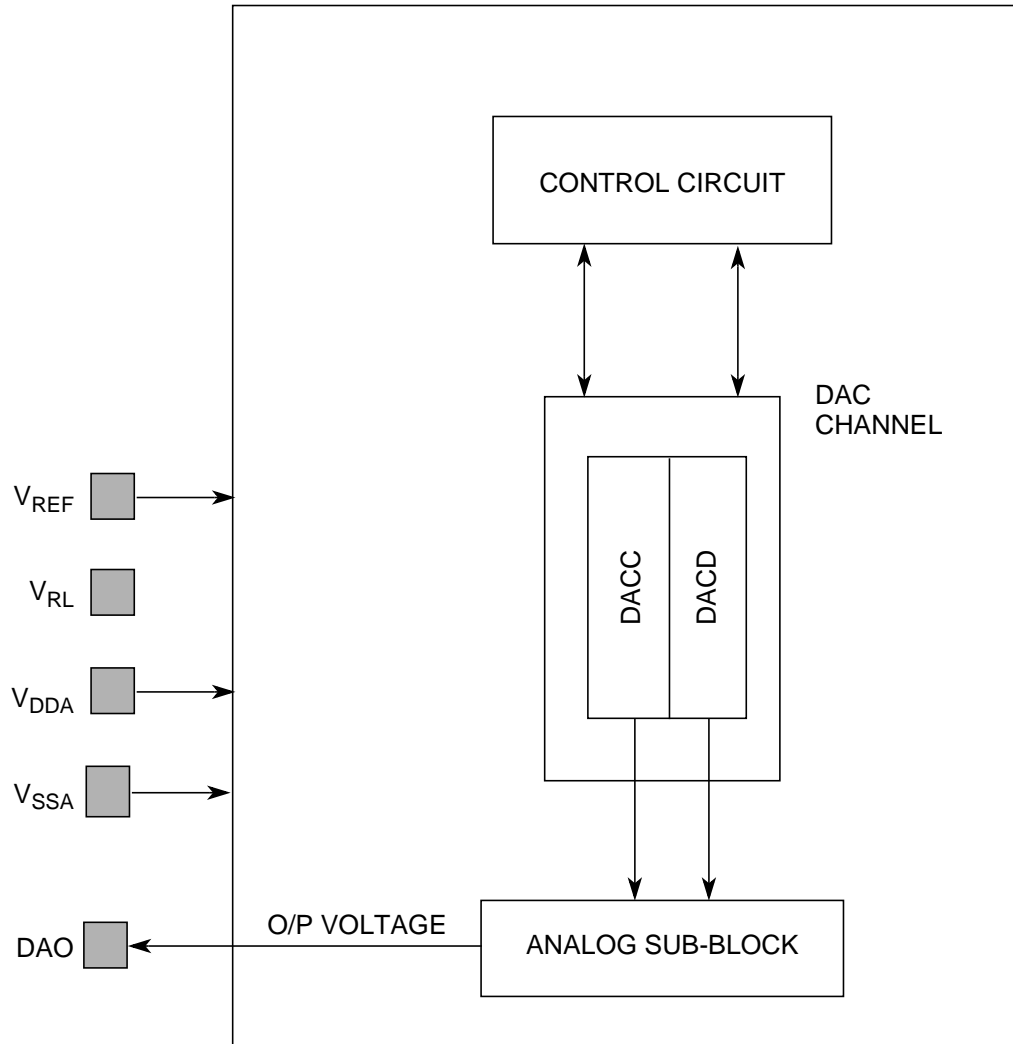

Figure 7-1. DAC8B1C Functional Block Diagram

7.2 Signal Description

The DAC8B1C module requires four external pins. These pins are listed in [Table 7-1](#) below.

Table 7-1. DAC8B1C External Pin Descriptions

Name	Function
DAO	DAC channel output
V _{DDA}	DAC power supply
V _{SSA}	DAC ground supply
V _{REF}	Reference voltage for DAC conversion
V _{RL}	Reference ground voltage connected to V _{SSA} outside the DAC boundary

7.2.1 DAO — DAC Channel Output

This pin is used as the analog output pin of the DAC8B1C module. The value represents the analog voltage level between V_{SSA} and V_{REF} .

7.2.2 V_{DDA} — DAC Power Supply

This pin serves as the power supply pin.

7.2.3 V_{SSA} — DAC Ground Supply

This pin serves as an analog ground reference to the DAC.

7.2.4 V_{REF} — DAC Reference Supply

This pin serves as the source for the high reference potential. Separation from the power supply pins accommodates the filtering necessary to achieve the accuracy of which the system is capable.

7.2.5 V_{RL} — DAC Reference Ground Supply

This pin serves as the ground for the low reference potential. This pin is connected to V_{SSA} outside the DAC module boundary to accommodate the filtering necessary to achieve the accuracy of which the system is capable.

7.3 Memory Map and Registers

This section provides a detailed description of all memory and registers accessible to the end user.

7.3.1 Module Memory Map

Figure 7-2 summarizes the DAC8B1C memory map. The base address is defined at the chip level and the address offset is defined at the module level.

Address	Name		Bit 7	6	5	4	3	2	1	Bit 0
0x0000	DACC0	R	DACE	DACTE	0	0	DJM	DSGN	DACWAI	DACOE
		W								
0x0001	DACC1	R	0	0	0	0	0	0	0	0
		W								
0x0002	DACD (Left Justified)	R	BIT 7	BIT 6	BIT 5	BIT 4	BIT 3	BIT 2	BIT 1	BIT 0
		W								
0x0003	DACD (Right Justified)	R	BIT 7	BIT 6	BIT 5	BIT 4	BIT 3	BIT 2	BIT 1	BIT 0
		W								

= Unimplemented or Reserved

Figure 7-2. DAC8B1C Register Summary

7.3.2 Register Descriptions

This section consists of register descriptions arranged in address order. Each description includes a standard register diagram with an associated figure number. Details of register bit and field function follow the register diagrams, in descending bit order.

7.3.2.1 DAC Control Register 0 (DACC0)

Module Base + 0x0000

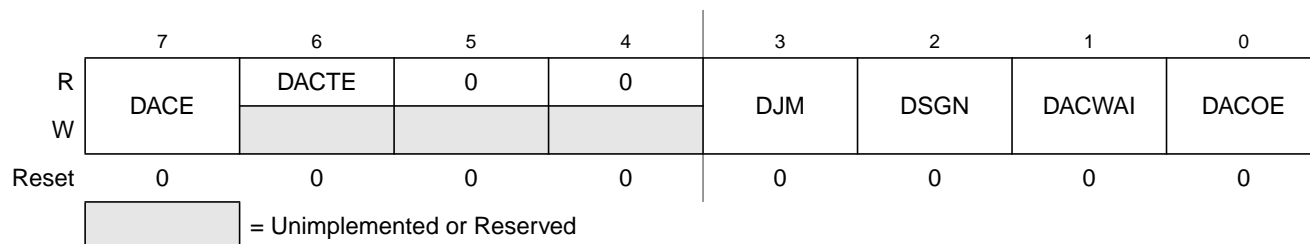

Figure 7-3. DAC Control Register 0 (DACC0)

Read: anytime (reserved locations read zero)

Write: anytime except DACTE is available only in special modes

Table 7-2. DACC0 Field Descriptions

Field	Description
7 DACE	DAC Enable — This bit enables digital-to-analog converter functionality. When enabled, an analog voltage based on the digital value in the DAC data register will be output. When disabled, DAO pin is high-impedance. 0 DAC is disabled and powered down 1 DAC is enabled for conversion
6 DACTE	DAC Test Enable — This reserved bit is designed for factory test purposes only and is not intended for general user access. Writing to this bit when in special test modes can alter DAC functionality.
3 DJM	Data Register Data Justification — This bit controls the justification of the data in the DAC data register (DACD). If DJM is clear (left-justified), the data to be converted must be written to left justified DACD and the right justified DACD register will read zeroes. If DJM is set (right-justified), the data to be converted is written to right justified DACD register and left justified DACD register reads zeroes. Data is preserved if DJM bit is changed after data is written. 0 Left justified data in DAC data register 1 Right justified data in DAC data register
2 DSGN	Data Register Signed — This bit selects between signed and unsigned conversion data representation in the DAC data register. Signed data is represented as 2's complement. 0 Unsigned data representation in DAC data register 1 Signed data representation in DAC data register
1 DACWAI	DAC Stop in WAIT Mode — DACWAI disables the DAC8B1C module (no new conversion is done) during wait mode. 0 DAC is enabled during wait mode 1 DAC is disabled and powered down during wait mode
0 DACOE	DAC Output Enable — This bit enables the output on the DAO pin. To output the DAC voltage, the DACOE bit and the DACE bit must be set. When disabled, DAO pin is high-impedance. 0 Output is not available for external use 1 Output on DAO pin enabled.

7.3.2.2 Reserved Register (DACC1)

This register is reserved.

Module Base + 0x0000

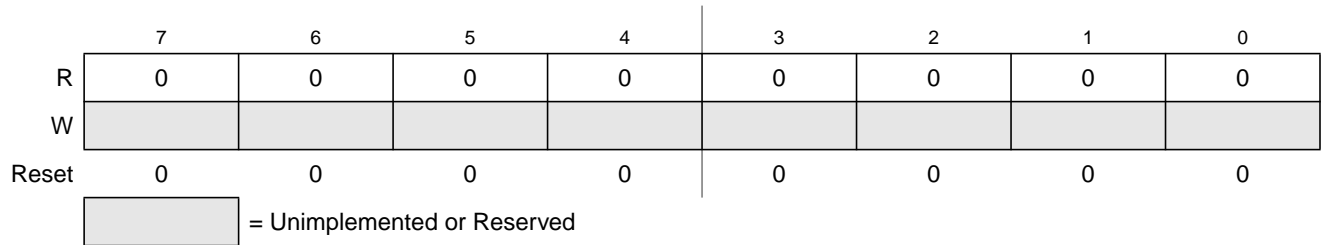

Figure 7-4. Reserved Register (DACC1)

Read: always read \$00

Write: unimplemented

7.3.2.3 DAC Data Register — Left Justified (DACD)

Module Base + 0x0002

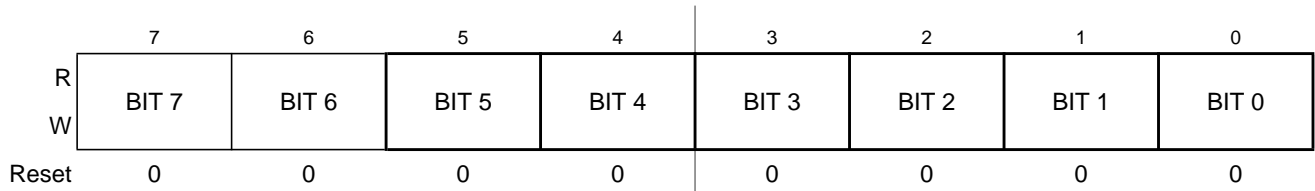

Figure 7-5. DAC Data Register — Left Justified (DACD)

Read: read zeroes when DJM is set

Write: unimplemented when DJM is set

The DAC data register is an 8-bit readable/writable register that stores the data to be converted when DJM bit is clear. When the DACE bit is set, the value in this register is converted into an analog voltage such that values from \$00 to \$FF result in equal voltage increments from V_{SSA} to V_{REF} . When DJM bit is set, this register reads zeroes and cannot be written.

7.3.2.4 DAC Data Register — Right Justified (DACD)

Module Base + 0x0003

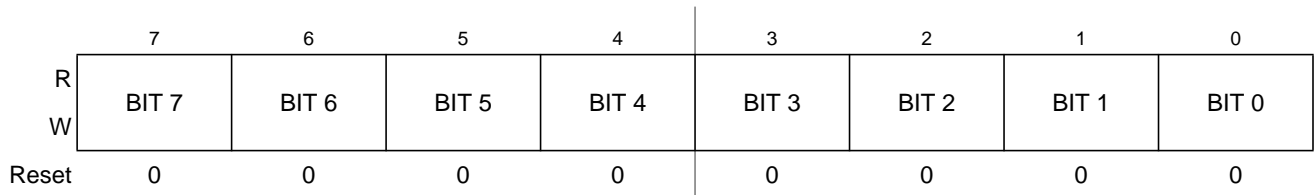

Figure 7-6. DAC Data Register — Right Justified (DACD)

Read: read zeroes when DJM is clear

Write: unimplemented when DJM is clear

The DAC data register is an 8-bit readable/writable register that stores the data to be converted when DJM bit is set. When the DACE bit is set, the value in this register is converted into an analog voltage such that values from \$00 to \$FF result in equal voltage increments from V_{SSA} to V_{REF} . When DJM bit is clear, this register reads zeroes and cannot be written.

7.4 Functional Description

The DAC8B1C module consists of analog and digital sub-blocks.

7.4.1 Functional Description

Data to be converted is written to DACD register. The data can be mapped either to left end or right end of DACD register by clearing or setting DJM bit of DACC0 register. Also, the data written to DACD can be a signed or unsigned data depending on DSGN bit of DACC0 register. See [Table 7-3](#) below for data formats. The maximum unsigned data that can be written to DACD register is \$FF while the minimum value is \$00. If the data is signed, the maximum value that can be written to DACD is \$7F while the minimum value is \$80, where \$7F (signed) corresponds to \$FF (unsigned) and \$80 (signed) corresponds to \$00 (unsigned). [Table 7-4](#) shows this characteristic between signed, unsigned data values and their corresponding voltage output. See [Table 7-4](#) for DAC signed and un-signed data and DAC output codes.

Table 7-3. Data Formats

DJM	DSGN	Description and Bus Bit Mapping
0	0	8 bit/left justified/unsigned — bits 15–8
0	1	8 bit/left justified/signed — bits 15–8
1	0	8 bit/right justified/unsigned — bits 7–0
1	1	8 bit/right justified/signed bits — 7–0

Table 7-4. Signed and Unsigned Data and DAC Output Codes

Input signal $V_{RL} = 0$ $V_{REF}/V_{RH} = 5.12\text{volts}$	Signed 8-Bit Codes	Unsigned 8-Bit Codes
5.12	7F	FF
5.08	7E	FE
5.07	7D	FD
2.580	01	81
2.56	00	80
2.54	FF	7F
2.52	FE	7E
0.020	81	01
0.000	80	00

Conversion of the data in DACD register takes place as soon as DACE bit of DACCC0 is set. The transfer characteristic of the day module is shown in Figure 7-7.

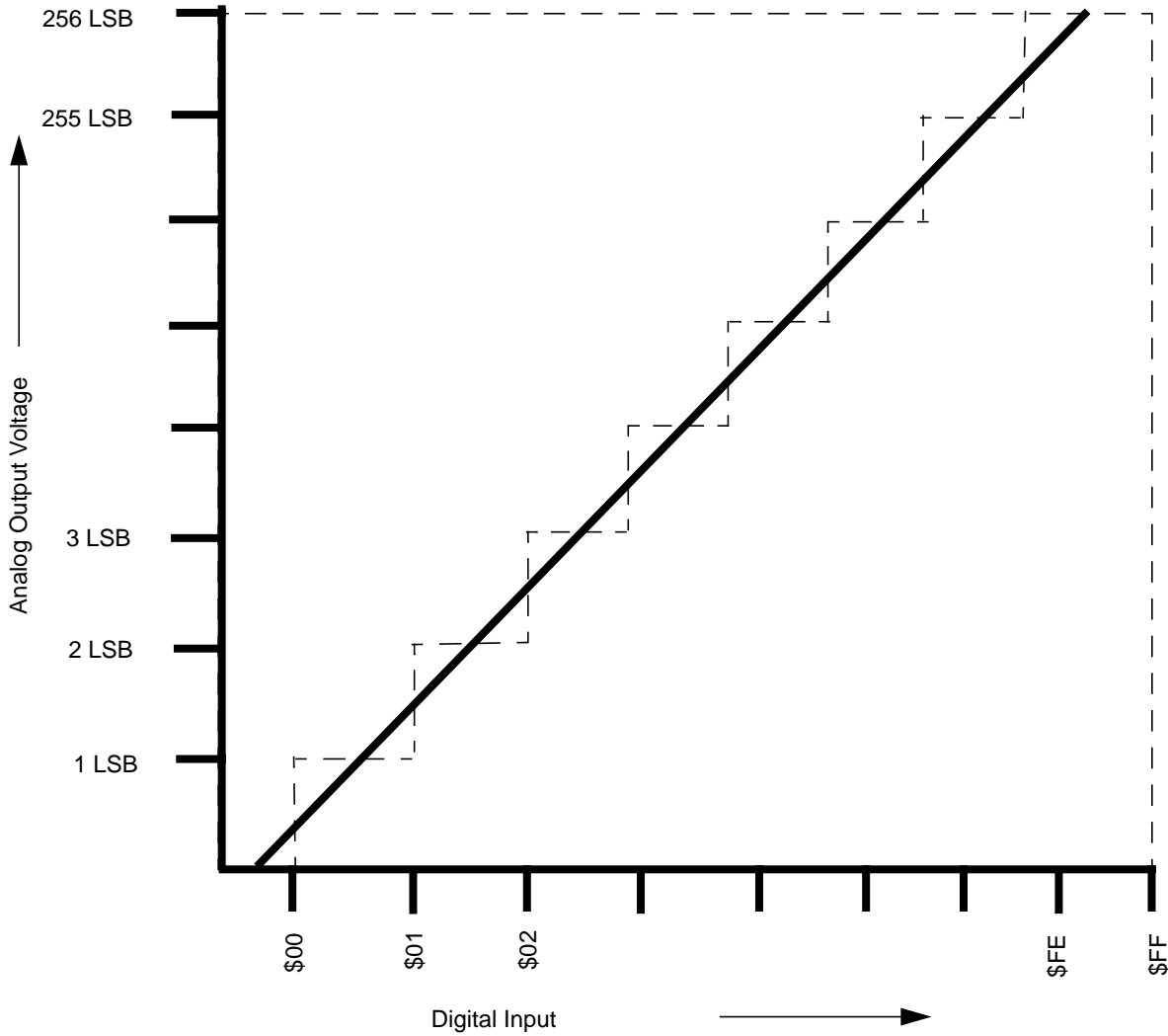

1 LSB = 21.5 mV when $V_{DDA} = 5.5 \text{ V}$

1 LSB = 11.5 mV when $V_{DDA} = 3.0 \text{ V}$

Figure 7-7. DAC8B1C Transfer Function

7.5 Resets

7.5.1 General

The DAC8B1C module is reset on a system reset. If the system reset signal is activated, the DAC registers are initialized to their reset state and the DAC8B1C module is powered down. This occurs as a function of the register file initialization. If the module is performing a conversion, the current conversion is terminated.

Chapter 8

Serial Communication Interface (SCIV4)

Block Description

8.1 Revision History

Table 8-1. SCI Revision History

Version Number	Revision Date	Effective Date	Author	Description of Changes
04.00	07/30/2002			Add two polarity configure bits to control the polarity of transmit data and receive data respectively; Add 1/4 pulse width option for TNP[1:0]=11 in SCIBDRH register.
04.02	04/16/2004			Update OR flag and PF flag description; Correct baud rate tolerance in 4.6.5.1 and 4.6.5.2; Clean up classification and NDA message banners

8.2 Introduction

This block description chapter provides an overview of serial communication interface (SCI) module.

The SCI allows full duplex, asynchronous, serial communication between the CPU and remote devices, including other CPUs. The SCI transmitter and receiver operate independently, although they use the same baud rate generator. The CPU monitors the status of the SCI, writes the data to be transmitted, and processes received data.

8.2.1 Glossary

IR: infrared

IrDA: Infrared Design Association

IRQ: interrupt request

LSB: least significant bit

MSB: most significant bit

NRZ: non-return-to-Zero

RZI: return-to-zero-inverted

RXD: receive pin

SCI: serial communication interface

TXD: transmit pin

8.2.2 Features

The SCI includes these distinctive features:

- Full-duplex or single-wire operation
- Standard mark/space non-return-to-zero (NRZ) format
- Selectable IrDA 1.4 return-to-zero-inverted (RZI) format with programmable pulse widths
- 13-bit baud rate selection
- Programmable 8-bit or 9-bit data format
- Separately enabled transmitter and receiver
- Programmable polarity for transmitter and receiver
- Programmable transmitter output parity
- Two receiver wakeup methods:
 - Idle line wakeup
 - Address mark wakeup
- Interrupt-driven operation with eight flags:
 - Transmitter empty
 - Transmission complete
 - Receiver full
 - Idle receiver input
 - Receiver overrun
 - Noise error
 - Framing error
 - Parity error
- Receiver framing error detection
- Hardware parity checking
- 1/16 bit-time noise detection

8.2.3 Modes of Operation

The SCI functions the same in normal, special, and emulation modes. It has two low-power modes, wait and stop modes.

8.2.3.1 Run Mode

Normal mode of operation.

8.2.3.2 Wait Mode

SCI operation in wait mode depends on the state of the SCISWAI bit in the SCI control register 1 (SCICR1).

- If SCISWAI is clear, the SCI operates normally when the CPU is in wait mode.
- If SCISWAI is set, SCI clock generation ceases and the SCI module enters a power-conservation state when the CPU is in wait mode. Setting SCISWAI does not affect the state of the receiver enable bit, RE, or the transmitter enable bit, TE.

If SCISWAI is set, any transmission or reception in progress stops at wait mode entry. The transmission or reception resumes when either an internal or external interrupt brings the CPU out of wait mode. Exiting wait mode by reset aborts any transmission or reception in progress and resets the SCI.

8.2.3.3 Stop Mode

The SCI is inactive during stop mode for reduced power consumption. The STOP instruction does not affect the SCI register states, but the SCI bus clock will be disabled. The SCI operation resumes after an external interrupt brings the CPU out of stop mode. Exiting stop mode by reset aborts any transmission or reception in progress and resets the SCI.

8.2.4 Block Diagram

Figure 8-1 is a high level block diagram of the SCI module, showing the interaction of various function blocks.

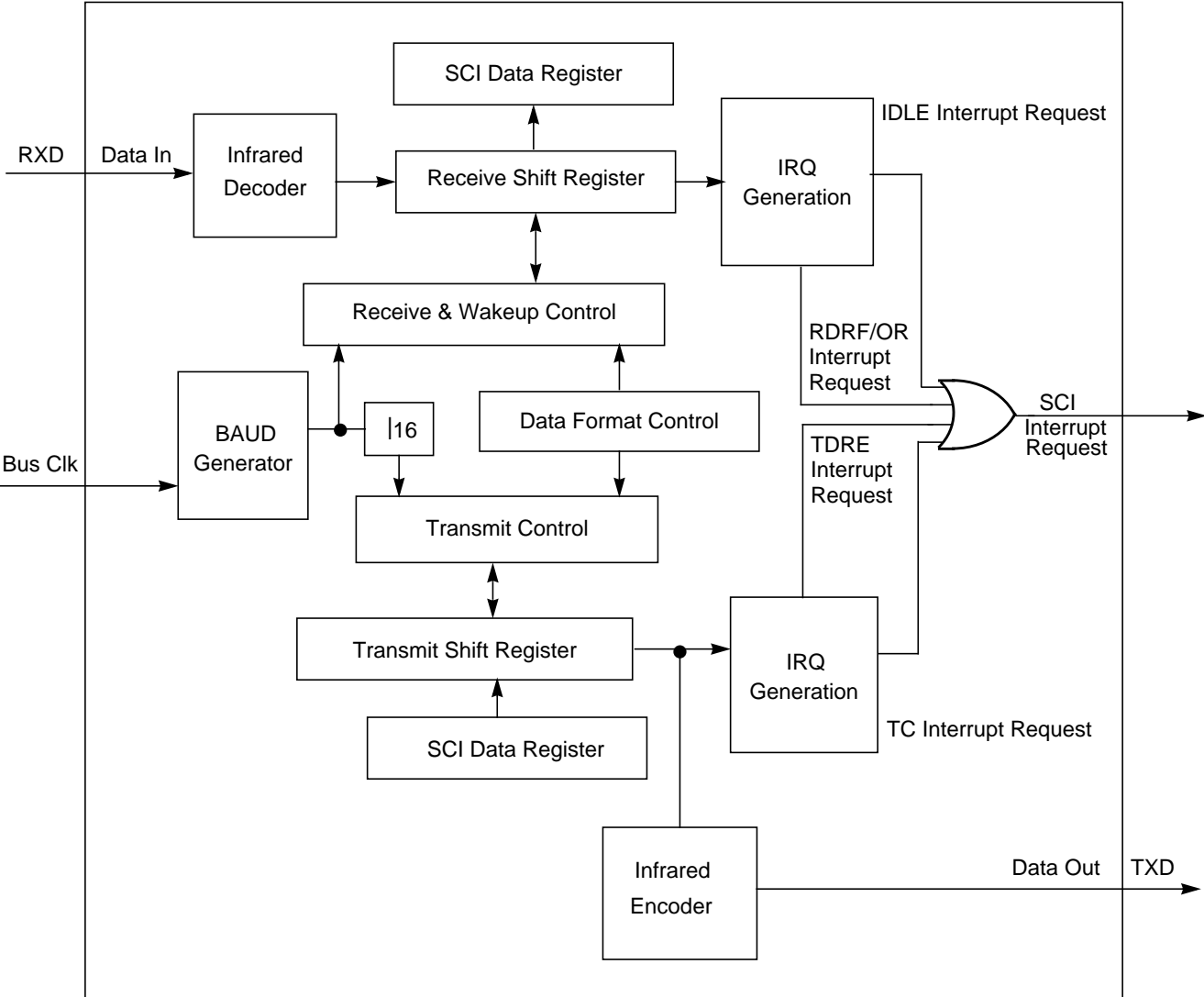

Figure 8-1. SCI Block Diagram

8.3 External Signal Descriptions

The SCI module has a total of two external pins.

8.3.1 TXD — SCI Transmit Pin

The TXD pin transmits SCI (standard or infrared) data. It will idle high in either mode and is high impedance anytime the transmitter is disabled.

8.3.2 RXD — SCI Receive Pin

The RXD pin receives SCI (standard or infrared) data. An idle line is detected as a line high. This input is ignored when the receiver is disabled and should be terminated to a known voltage.

8.4 Memory Map and Register Definition

This subsection provides a detailed description of all the SCI registers.

8.4.1 Module Memory Map

The memory map for the SCI module is given in [Figure 8-2](#). The address listed for each register is the address offset. The total address for each register is the sum of the base address for the SCI module and the address offset for each register.

8.4.2 Register Descriptions

This subsection consists of register descriptions in address order. Each description includes a standard register diagram with an associated figure number. Writes to reserved register locations do not have any effect and reads of these locations return a 0. Details of register bit and field function follow the register diagrams, in bit order.

Register Name		Bit 7	6	5	4	3	2	1	Bit 0
0x0000 SCIBDH	R W	IREN	TNP1	TNP0	SBR12	SBR11	SBR10	SBR9	SBR8
0x0001 SCIBDL	R W	SBR7	SBR6	SBR5	SBR4	SBR3	SBR2	SBR1	SBR0
0x0002 SCICR1	R W	LOOPS	SCISWAI	RSRC	M	WAKE	ILT	PE	PT

 = Unimplemented or Reserved

Figure 8-2. SCI Registers Summary

Register Name		Bit 7	6	5	4	3	2	1	Bit 0
0x0003 SCICR2	R	TIE	TCIE	RIE	ILIE	TE	RE	RWU	SBK
	W								
0x0004 SCISR1	R	TDRE	TC	RDRF	IDLE	OR	NF	FE	PF
	W								
0x0005 SCISR2	R	0	0	0	TXPOL	RXPOL	BRK13	TXDIR	RAF
	W								
0x0006 SCIDRH	R	R8	T8	0	0	0	0	0	0
	W								
0x0007 SCIDRL	R	R7	R6	R5	R4	R3	R2	R1	R0
	W	T7	T6	T5	T4	T3	T2	T1	T0

= Unimplemented or Reserved

Figure 8-2. SCI Registers Summary

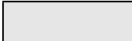
8.4.2.1 SCI Baud Rate Registers (SCIBDH and SCIBDL)

Module Base + 0x0000

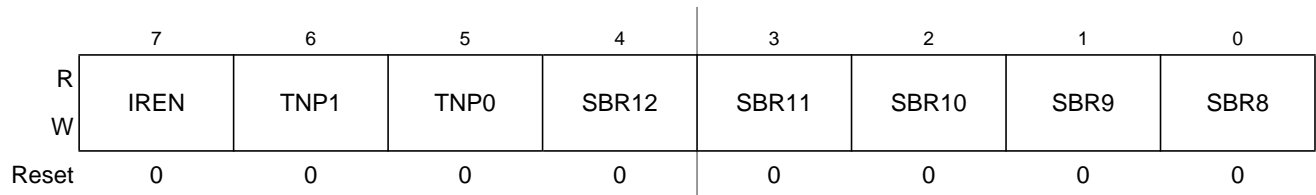
Figure 8-3. SCI Baud Rate Register High (SCIBDH)
Table 8-2. SCIBDH Field Descriptions

Field	Description
7 IREN	Infrared Enable Bit — This bit enables/disables the infrared modulation/demodulation submodule. 0 IR disabled 1 IR enabled
6:5 TNP[1:0]	Transmitter Narrow Pulse Bits — These bits determine if the SCI will transmit a 1/16, 3/16, 1/32, or 1/4 narrow pulse. Refer to Table 8-4 .
4:0 SBR[11:8]	SCI Baud Rate Bits — The baud rate for the SCI is determined by the bits in this register. The baud rate is calculated two different ways depending on the state of the IREN bit. The formulas for calculating the baud rate are: When IREN = 0 then, SCI baud rate = SCI module clock / (16 x SBR[12:0]) When IREN = 1 then, SCI baud rate = SCI module clock / (32 x SBR[12:1])

Module Base + 0x0001

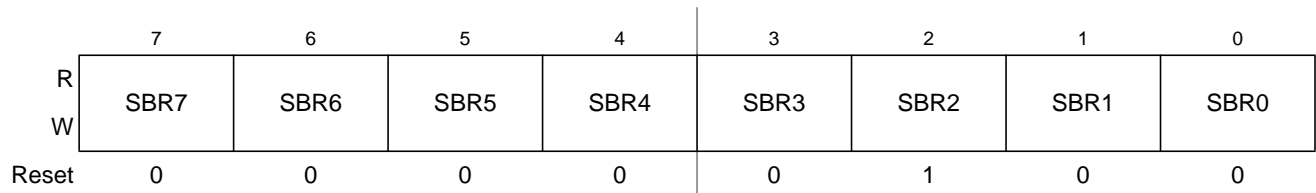
Figure 8-4. SCI Baud Rate Register Low (SCIBDL)
Table 8-3. SCIBDL Field Descriptions

Field	Description
7:0 SBR[7:0]	SCI Baud Rate Bits — The baud rate for the SCI is determined by the bits in this register. The baud rate is calculated two different ways depending on the state of the IREN bit. The formulas for calculating the baud rate are: When IREN = 0 then, SCI baud rate = SCI module clock / (16 x SBR[12:0]) When IREN = 1 then, SCI baud rate = SCI module clock / (32 x SBR[12:1])

Read: anytime

NOTE

If only SCIBDH is written to, a read will not return the correct data until SCIBDL is written to as well, following a write to SCIBDH.

Write: anytime

The SCI baud rate register is used to determine the baud rate of the SCI and to control the infrared modulation/demodulation submodule.

Table 8-4. IRSCI Transmit Pulse Width

TNP[1:0]	Narrow Pulse Width
11	1/4
10	1/32
01	1/16
00	3/16

NOTE

The baud rate generator is disabled after reset and not started until the TE bit or the RE bit is set for the first time. The baud rate generator is disabled when (SBR[12:0] = 0 and IREN = 0) or (SBR[12:1] = 0 and IREN = 1).

Writing to SCIBDH has no effect without writing to SCIBDL, because writing to SCIBDH puts the data in a temporary location until SCIBDL is written to.

8.4.2.2 SCI Control Register 1 (SCICR1)

Module Base + 0x0002

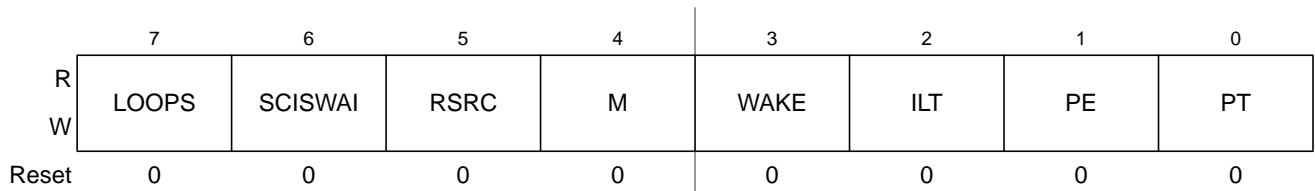

Figure 8-5. SCI Control Register 1 (SCICR1)

Read: anytime

Write: anytime

Table 8-5. SCICR1 Field Descriptions

Field	Description
7 LOOPS	<p>Loop Select Bit — LOOPS enables loop operation. In loop operation, the RXD pin is disconnected from the SCI and the transmitter output is internally connected to the receiver input. Both the transmitter and the receiver must be enabled to use the loop function.</p> <p>0 Normal operation enabled 1 Loop operation enabled</p> <p>The receiver input is determined by the RSRC bit.</p>
6 SCISWAI	<p>SCI Stop in Wait Mode Bit — SCISWAI disables the SCI in wait mode.</p> <p>0 SCI enabled in wait mode 1 SCI disabled in wait mode</p>
5 RSRC	<p>Receiver Source Bit — When LOOPS = 1, the RSRC bit determines the source for the receiver shift register input.</p> <p>0 Receiver input internally connected to transmitter output 1 Receiver input connected externally to transmitter</p> <p>Refer to Table 8-6.</p>
4 M	<p>Data Format Mode Bit — MODE determines whether data characters are eight or nine bits long.</p> <p>0 One start bit, eight data bits, one stop bit 1 One start bit, nine data bits, one stop bit</p>
3 WAKE	<p>Wakeup Condition Bit — WAKE determines which condition wakes up the SCI: a logic 1 (address mark) in the most significant bit position of a received data character or an idle condition on the RXD pin.</p> <p>0 Idle line wakeup 1 Address mark wakeup</p>
2 ILT	<p>Idle Line Type Bit — ILT determines when the receiver starts counting logic 1s as idle character bits. The counting begins either after the start bit or after the stop bit. If the count begins after the start bit, then a string of logic 1s preceding the stop bit may cause false recognition of an idle character. Beginning the count after the stop bit avoids false idle character recognition, but requires properly synchronized transmissions.</p> <p>0 Idle character bit count begins after start bit 1 Idle character bit count begins after stop bit</p>
1 PE	<p>Parity Enable Bit — PE enables the parity function. When enabled, the parity function inserts a parity bit in the most significant bit position.</p> <p>0 Parity function disabled 1 Parity function enabled</p>
0 PT	<p>Parity Type Bit — PT determines whether the SCI generates and checks for even parity or odd parity. With even parity, an even number of 1s clears the parity bit and an odd number of 1s sets the parity bit. With odd parity, an odd number of 1s clears the parity bit and an even number of 1s sets the parity bit.</p> <p>0 Even parity 1 Odd parity</p>

Table 8-6. Loop Functions

LOOPS	RSRC	Function
0	x	Normal operation
1	0	Loop mode with transmitter output internally connected to receiver input
1	1	Single-wire mode with TXD pin connected to receiver input

8.4.2.3 SCI Control Register 2 (SCICR2)

Module Base + 0x0003

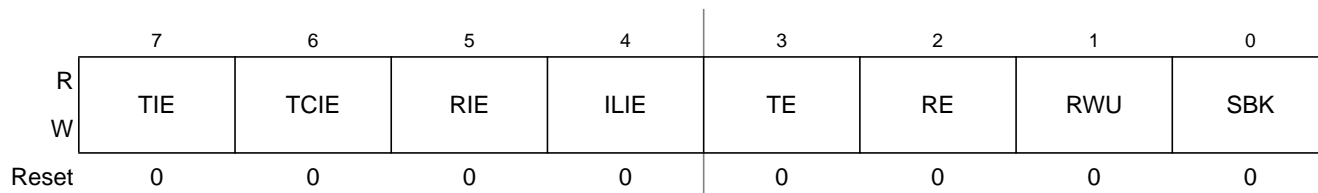

Figure 8-6. SCI Control Register 2 (SCICR2)

Read: anytime

Write: anytime

Table 8-7. SCICR2 Field Descriptions

Field	Description
7 TIE	Transmitter Interrupt Enable Bit — TIE enables the transmit data register empty flag, TDRE, to generate interrupt requests. 0 TDRE interrupt requests disabled 1 TDRE interrupt requests enabled
6 TCIE	Transmission Complete Interrupt Enable Bit — TCIE enables the transmission complete flag, TC, to generate interrupt requests. 0 TC interrupt requests disabled 1 TC interrupt requests enabled
5 RIE	Receiver Full Interrupt Enable Bit — RIE enables the receive data register full flag, RDRF, or the overrun flag, OR, to generate interrupt requests. 0 RDRF and OR interrupt requests disabled 1 RDRF and OR interrupt requests enabled
4 ILIE	Idle Line Interrupt Enable Bit — ILIE enables the idle line flag, IDLE, to generate interrupt requests. 0 IDLE interrupt requests disabled 1 IDLE interrupt requests enabled
3 TE	Transmitter Enable Bit — TE enables the SCI transmitter and configures the TXD pin as being controlled by the SCI. The TE bit can be used to queue an idle preamble. 0 Transmitter disabled 1 Transmitter enabled
2 RE	Receiver Enable Bit — RE enables the SCI receiver. 0 Receiver disabled 1 Receiver enabled
1 RWU	Receiver Wakeup Bit — Standby state 0 Normal operation. 1 RWU enables the wakeup function and inhibits further receiver interrupt requests. Normally, hardware wakes the receiver by automatically clearing RWU.
0 SBK	Send Break Bit — Toggling SBK sends one break character (10 or 11 logic 0s, respectively 13 or 14 logics 0s if BRK13 is set). Toggling implies clearing the SBK bit before the break character has finished transmitting. As long as SBK is set, the transmitter continues to send complete break characters (10 or 11 bits, respectively 13 or 14 bits). 0 No break characters 1 Transmit break characters

8.4.2.4 SCI Status Register 1 (SCISR1)

The SCISR1 and SCISR2 registers provide inputs to the MCU for generation of SCI interrupts. Also, these registers can be polled by the MCU to check the status of these bits. The flag-clearing procedures require that the status register be read followed by a read or write to the SCI data register. It is permissible to execute other instructions between the two steps as long as it does not compromise the handling of I/O. Note that the order of operations is important for flag clearing.

Module Base + 0x0004

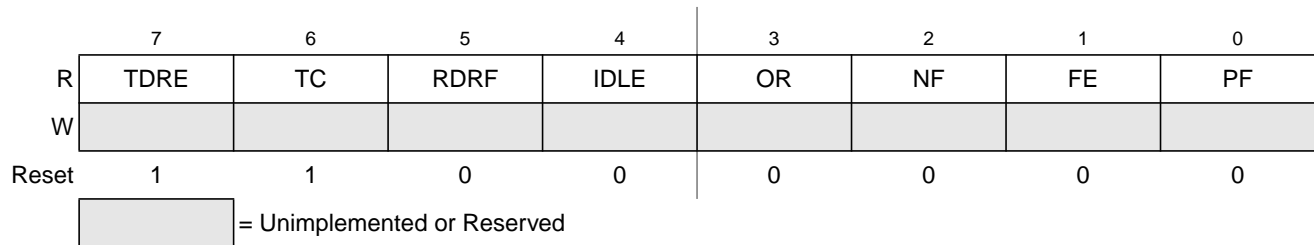

Figure 8-7. SCI Status Register 1 (SCISR1)

Read: anytime

Write: has no meaning or effect

Table 8-8. SCISR1 Field Descriptions

Field	Description
7 TDRE	<p>Transmit Data Register Empty Flag — TDRE is set when the transmit shift register receives a byte from the SCI data register. When TDRE is 1, the transmit data register (SCIDRH/L) is empty and can receive a new value to transmit. Clear TDRE by reading SCI status register 1 (SCISR1), with TDRE set and then writing to SCI data register low (SCIDRL).</p> <p>0 No byte transferred to transmit shift register 1 Byte transferred to transmit shift register; transmit data register empty</p>
6 TC	<p>Transmit Complete Flag — TC is set low when there is a transmission in progress or when a preamble or break character is loaded. TC is set high when the TDRE flag is set and no data, preamble, or break character is being transmitted. When TC is set, the TXD pin becomes idle (logic 1). Clear TC by reading SCI status register 1 (SCISR1) with TC set and then writing to SCI data register low (SCIDRL). TC is cleared automatically when data, preamble, or break is queued and ready to be sent. TC is cleared in the event of a simultaneous set and clear of the TC flag (transmission not complete).</p> <p>0 Transmission in progress 1 No transmission in progress</p>
5 RDRF	<p>Receive Data Register Full Flag — RDRF is set when the data in the receive shift register transfers to the SCI data register. Clear RDRF by reading SCI status register 1 (SCISR1) with RDRF set and then reading SCI data register low (SCIDRL).</p> <p>0 Data not available in SCI data register 1 Received data available in SCI data register</p>
4 IDLE	<p>Idle Line Flag¹ — IDLE is set when 10 consecutive logic 1s (if M = 0) or 11 consecutive logic 1s (if M = 1) appear on the receiver input. After the IDLE flag is cleared, a valid frame must again set the RDRF flag before an idle condition can set the IDLE flag. Clear IDLE by reading SCI status register 1 (SCISR1) with IDLE set and then reading SCI data register low (SCIDRL).</p> <p>0 Receiver input is either active now or has never become active since the IDLE flag was last cleared 1 Receiver input has become idle</p>

Table 8-8. SCISR1 Field Descriptions (continued)

Field	Description
3 OR	Overrun Flag ² — OR is set when software fails to read the SCI data register before the receive shift register receives the next frame. The OR bit is set immediately after the stop bit has been completely received for the second frame. The data in the shift register is lost, but the data already in the SCI data registers is not affected. Clear OR by reading SCI status register 1 (SCISR1) with OR set and then reading SCI data register low (SCIDRL). 0 No overrun 1 Overrun
2 NF	Noise Flag — NF is set when the SCI detects noise on the receiver input. NF bit is set during the same cycle as the RDRF flag but does not get set in the case of an overrun. Clear NF by reading SCI status register 1 (SCISR1), and then reading SCI data register low (SCIDRL). 0 No noise 1 Noise
1 FE	Framing Error Flag — FE is set when a logic 0 is accepted as the stop bit. FE bit is set during the same cycle as the RDRF flag but does not get set in the case of an overrun. FE inhibits further data reception until it is cleared. Clear FE by reading SCI status register 1 (SCISR1) with FE set and then reading the SCI data register low (SCIDRL). 0 No framing error 1 Framing error
0 PF	Parity Error Flag — PF is set when the parity enable bit (PE) is set and the parity of the received data does not match the parity type bit (PT). PF bit is set during the same cycle as the RDRF flag but does not get set in the case of an overrun. Clear PF by reading SCI status register 1 (SCISR1), and then reading SCI data register low (SCIDRL). 0 No parity error 1 Parity error

¹ When the receiver wakeup bit (RWU) is set, an idle line condition does not set the IDLE flag.

² The OR flag may read back as set when RDRF flag is clear. This may happen if the following sequence of events occurs:

1. After the first frame is received, read status register SCISR1 (returns RDRF set and OR flag clear);
2. Receive second frame without reading the first frame in the data register (the second frame is not received and OR flag is set);
3. Read data register SCIDRL (returns first frame and clears RDRF flag in the status register);
4. Read status register SCISR1 (returns RDRF clear and OR set).

Event 3 may be at exactly the same time as event 2 or any time after. When this happens, a dummy SCIDRL read following event 4 will be required to clear the OR flag if further frames are to be received.

8.4.2.5 SCI Status Register 2 (SCISR2)

Module Base + 0x0005

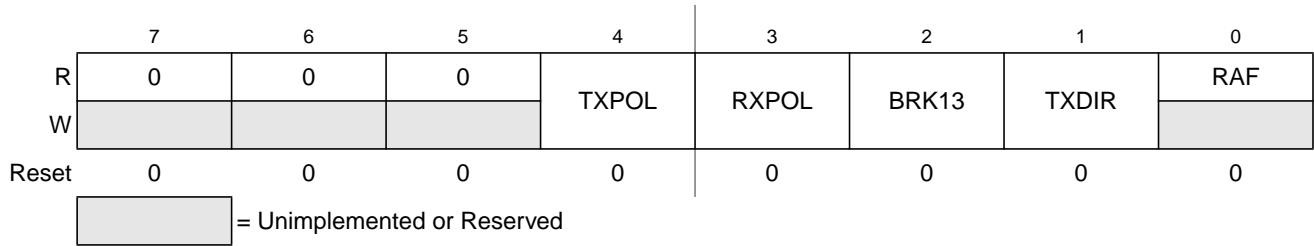

Figure 8-8. SCI Status Register 2 (SCISR2)

Read: anytime

Write: anytime

Table 8-9. SCISR2 Field Descriptions

Field	Description
4 TXPOL	Transmit Polarity — This bit control the polarity of the transmitted data. In NRZ format, a 1 is represented by a mark and a 0 is represented by a space for normal polarity, and the opposite for inverted polarity. In IrDA format, a 0 is represented by short high pulse in the middle of a bit time remaining idle low for a 1 for normal polarity, and a 0 is represented by short low pulse in the middle of a bit time remaining idle high for a 1 for inverted polarity. 0 Normal polarity 1 Inverted polarity
3 RXPOL	Receive Polarity — This bit control the polarity of the received data. In NRZ format, a 1 is represented by a mark and a 0 is represented by a space for normal polarity, and the opposite for inverted polarity. In IrDA format, a 0 is represented by short high pulse in the middle of a bit time remaining idle low for a 1 for normal polarity, and a 0 is represented by short low pulse in the middle of a bit time remaining idle high for a 1 for inverted polarity. 0 Normal polarity 1 Inverted polarity
2 BRK13	Break Transmit Character Length — This bit determines whether the transmit break character is 10 or 11 bit respectively 13 or 14 bits long. The detection of a framing error is not affected by this bit. 0 Break character is 10 or 11 bit long 1 Break character is 13 or 14 bit long
1 TXDIR	Transmitter Pin Data Direction in Single-Wire Mode — This bit determines whether the TXD pin is going to be used as an input or output, in the single-wire mode of operation. This bit is only relevant in the single-wire mode of operation. 0 TXD pin to be used as an input in single-wire mode 1 TXD pin to be used as an output in single-wire mode
0 RAF	Receiver Active Flag — RAF is set when the receiver detects a logic 0 during the RT1 time period of the start bit search. RAF is cleared when the receiver detects an idle character. 0 No reception in progress 1 Reception in progress

8.4.2.6 SCI Data Registers (SCIDRH and SCIDRL)

Module Base + 0x0006

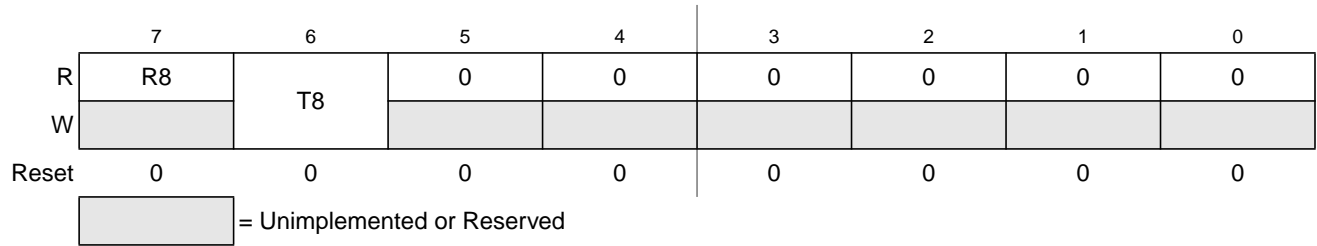

Figure 8-9. SCI Data Register High (SCIDRH)

Table 8-10. SCIDRH Field Descriptions

Field	Description
7 R8	Received Bit 8 — R8 is the ninth data bit received when the SCI is configured for 9-bit data format (M = 1).
6 T8	Transmit Bit 8 — T8 is the ninth data bit transmitted when the SCI is configured for 9-bit data format (M = 1).

Module Base + 0x0007

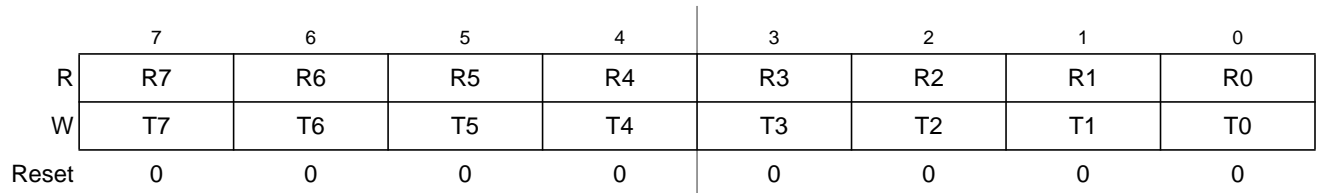

Figure 8-10. SCI Data Register Low (SCIDRL)

Read: anytime; reading accesses SCI receive data register

Write: anytime; writing accesses SCI transmit data register; writing to R8 has no effect

Table 8-11. SCIDRL Field Descriptions

Field	Description
7:0 R[7:0] T[7:0]	Received bits 7 through 0 — For 9-bit or 8-bit data formats Transmit bits 7 through 0 — For 9-bit or 8-bit formats

NOTE

If the value of T8 is the same as in the previous transmission, T8 does not have to be rewritten. The same value is transmitted until T8 is rewritten

In 8-bit data format, only SCI data register low (SCIDRL) needs to be accessed.

When transmitting in 9-bit data format and using 8-bit write instructions, write first to SCI data register high (SCIDRH) then to SCIDRL.

8.5 Functional Description

This subsection provides a complete functional description of the SCI block, detailing the operation of the design from the end user's perspective in a number of descriptions.

Figure 8-11 shows the structure of the SCI module. The SCI allows full duplex, asynchronous, serial communication between the CPU and remote devices, including other CPUs. The SCI transmitter and receiver operate independently, although they use the same baud rate generator. The CPU monitors the status of the SCI, writes the data to be transmitted, and processes received data.

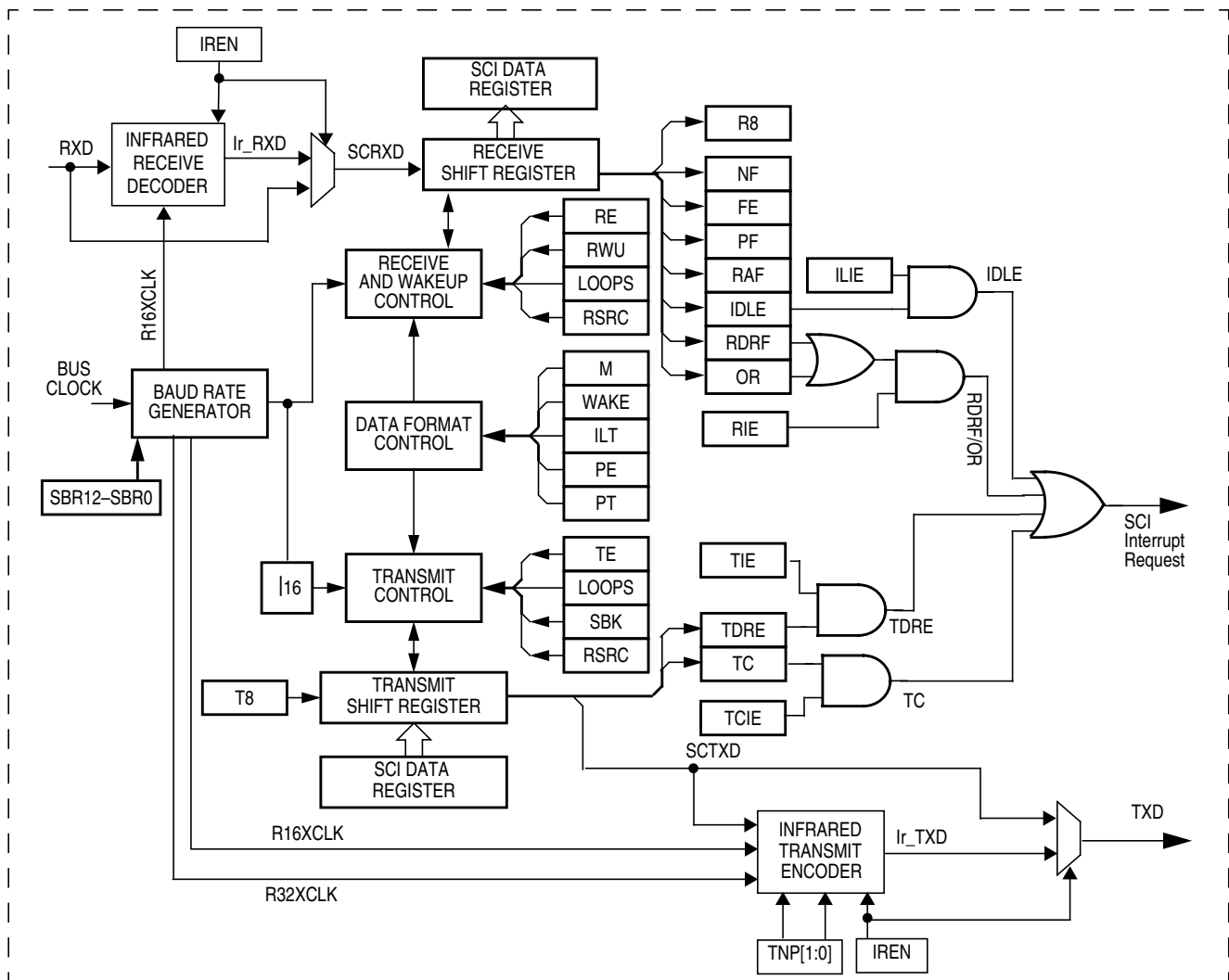

Figure 8-11. Detailed SCI Block Diagram

8.5.1 Infrared Interface Submodule

This module provides the capability of transmitting narrow pulses to an IR LED and receiving narrow pulses and transforming them to serial bits, which are sent to the SCI. The IrDA physical layer specification defines a half-duplex infrared communication link for exchange data. The full standard includes data rates up to 16 Mbits/s. This design covers only data rates between 2.4 kbits/s and 115.2 kbits/s.

The infrared submodule consists of two major blocks: the transmit encoder and the receive decoder. The SCI transmits serial bits of data which are encoded by the infrared submodule to transmit a narrow pulse for every 0 bit. No pulse is transmitted for every 1 bit. When receiving data, the IR pulses should be detected using an IR photo diode and transformed to CMOS levels by the IR receive decoder (external from the MCU). The narrow pulses are then stretched by the infrared submodule to get back to a serial bit stream to be received by the SCI. The polarity of transmitted pulses and expected receive pulses can be inverted so that a direct connection can be made to external IrDA transceiver modules that uses active low pulses.

The infrared submodule receives its clock sources from the SCI. One of these two clocks are selected in the infrared submodule in order to generate either 3/16, 1/16, 1/32, or 1/4 narrow pulses during transmission. The infrared block receives two clock sources from the SCI, R16XCLK, and R32XCLK, which are configured to generate the narrow pulse width during transmission. The R16XCLK and R32XCLK are internal clocks with frequencies 16 and 32 times the baud rate respectively. Both R16XCLK and R32XCLK clocks are used for transmitting data. The receive decoder uses only the R16XCLK clock.

8.5.1.1 Infrared Transmit Encoder

The infrared transmit encoder converts serial bits of data from transmit shift register to the TXD pin. A narrow pulse is transmitted for a 0 bit and no pulse for a 1 bit. The narrow pulse is sent in the middle of the bit with a duration of 1/32, 1/16, 3/16, or 1/4 of a bit time. A narrow high pulse is transmitted for a 0 bit when TXPOL is cleared, while a narrow low pulse is transmitted for a 0 bit when TXPOL is set.

8.5.1.2 Infrared Receive Decoder

The infrared receive block converts data from the RXD pin to the receive shift register. A narrow pulse is expected for each 0 received and no pulse is expected for each 1 received. A narrow high pulse is expected for a 0 bit when RXPOL is cleared, while a narrow low pulse is expected for a 0 bit when RXPOL is set. This receive decoder meets the edge jitter requirement as defined by the IrDA serial infrared physical layer specification.

8.5.2 Data Format

The SCI uses the standard NRZ mark/space data format. When Infrared is enabled, the SCI uses RZI data format where 0s are represented by light pulses and 1s remain low. See [Figure 8-12](#).

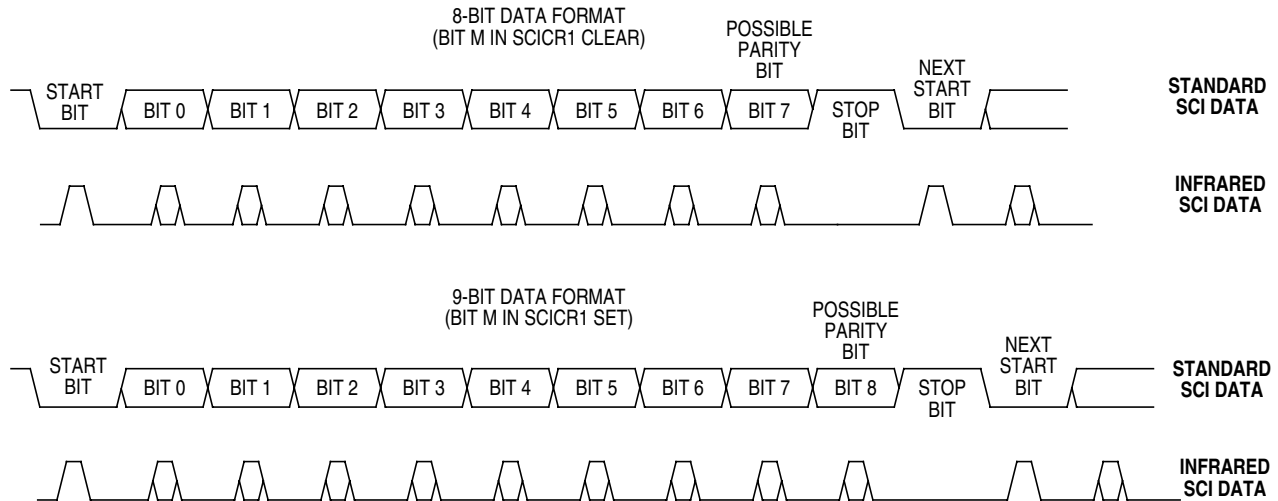

Figure 8-12. SCI Data Formats

Each data character is contained in a frame that includes a start bit, eight or nine data bits, and a stop bit. Clearing the M bit in SCI control register 1 configures the SCI for 8-bit data characters. A frame with eight data bits has a total of 10 bits. Setting the M bit configures the SCI for nine-bit data characters. A frame with nine data bits has a total of 11 bits

Table 8-12. Example of 8-bit Data Formats

Start Bit	Data Bits	Address Bits	Parity Bits	Stop Bit
1	8	0	0	1
1	7	0	1	1
1	7	1 ¹	0	1

¹ The address bit identifies the frame as an address character. See [Section 8.5.5.6, "Receiver Wakeup"](#).

When the SCI is configured for 9-bit data characters, the ninth data bit is the T8 bit in SCI data register high (SCIDRH). It remains unchanged after transmission and can be used repeatedly without rewriting it. A frame with nine data bits has a total of 11 bits.

Table 8-13. Example of 9-Bit Data Formats

Start Bit	Data Bits	Address Bits	Parity Bits	Stop Bit
1	9	0	0	1
1	8	0	1	1
1	8	1 ¹	0	1

¹ The address bit identifies the frame as an address character. See [Section 8.5.5.6, "Receiver Wakeup"](#).

8.5.3 Baud Rate Generation

A 13-bit modulus counter in the baud rate generator derives the baud rate for both the receiver and the transmitter. The value from 0 to 8191 written to the SBR[12:0] bits determines the module clock divisor. The SBR bits are in the SCI baud rate registers (SCIBDH and SCIBDL). The baud rate clock is synchronized with the bus clock and drives the receiver. The baud rate clock divided by 16 drives the transmitter. The receiver has an acquisition rate of 16 samples per bit time.

Baud rate generation is subject to one source of error:

- Integer division of the module clock may not give the exact target frequency.

Table 8-14 lists some examples of achieving target baud rates with a module clock frequency of 10.2 MHz.

When IREN = 0 then,

$$\text{SCI baud rate} = \text{SCI module clock} / (16 * \text{SCIBR}[12:0])$$

Table 8-14. Baud Rates (Example: Module Clock = 10.2 MHz)

Bits SBR[12-0]	Receiver Clock (Hz)	Transmitter Clock (Hz)	Target Baud Rate	Error (%)
17	600,000.0	37,500.0	38,400	2.3
33	309,090.9	19,318.2	19,200	.62
66	154,545.5	9659.1	9600	.62
133	76,691.7	4793.2	4800	.14
266	38,345.9	2396.6	2400	.14
531	19,209.0	1200.6	1200	.11
1062	9604.5	600.3	600	.05
2125	4800.0	300.0	300	.00
4250	2400.0	150.0	150	.00
5795	1760.1	110.0	110	.00

8.5.4 Transmitter

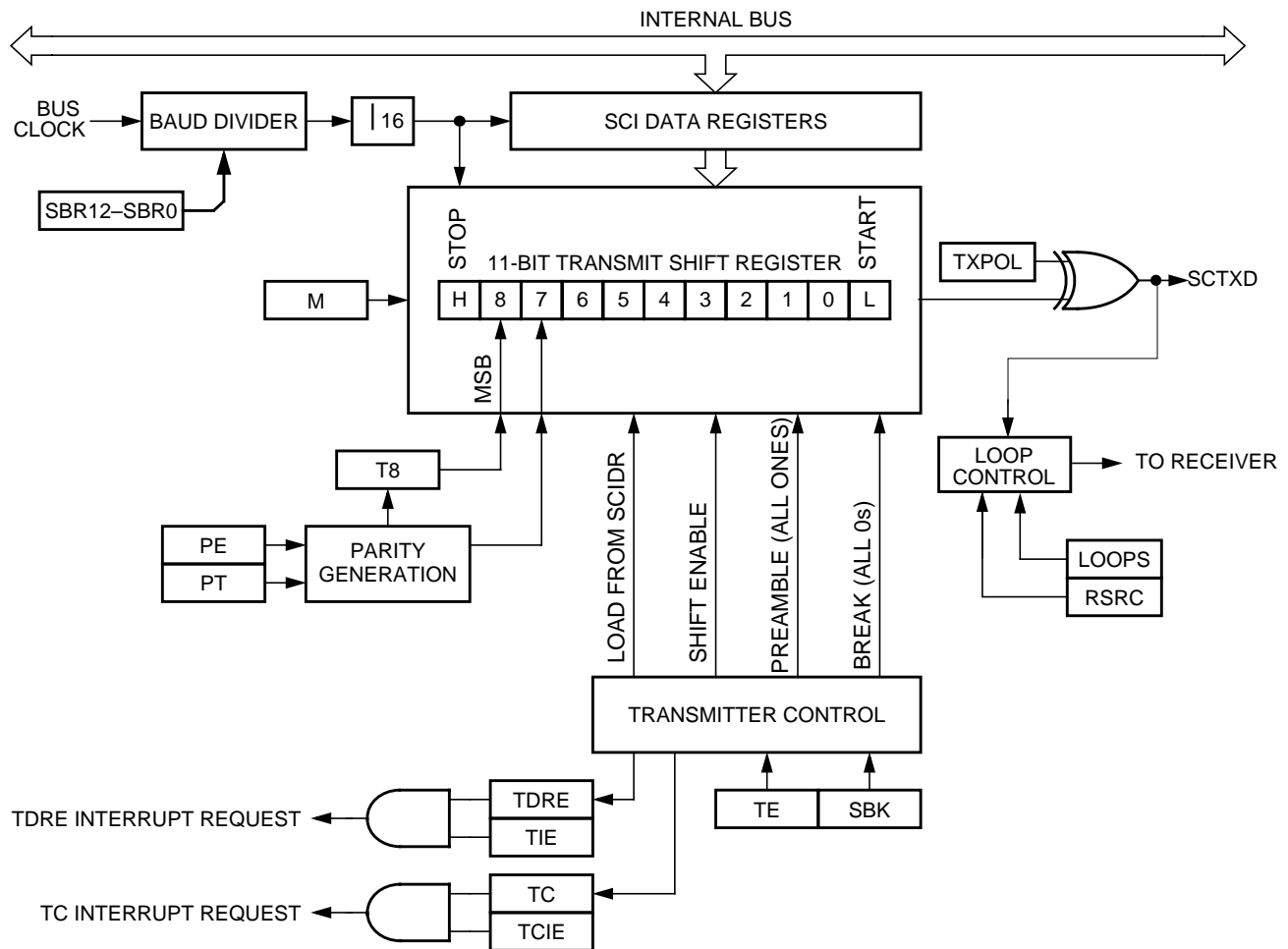

Figure 8-13. Transmitter Block Diagram

8.5.4.1 Transmitter Character Length

The SCI transmitter can accommodate either 8-bit or 9-bit data characters. The state of the M bit in SCI control register 1 (SCICR1) determines the length of data characters. When transmitting 9-bit data, bit T8 in SCI data register high (SCIDRH) is the ninth bit (bit 8).

8.5.4.2 Character Transmission

To transmit data, the MCU writes the data bits to the SCI data registers (SCIDRH/SCIDRL), which in turn are transferred to the transmitter shift register. The transmit shift register then shifts a frame out through the TXD pin, after it has prefaced them with a start bit and appended them with a stop bit. The SCI data registers (SCIDRH and SCIDRL) are the write-only buffers between the internal data bus and the transmit shift register.

The SCI also sets a flag, the transmit data register empty flag (TDRE), every time it transfers data from the buffer (SCIDRH/L) to the transmitter shift register. The transmit driver routine may respond to this

flag by writing another byte to the transmitter buffer (SCIDRH/SCIDRL), while the shift register is shifting out the first byte.

To initiate an SCI transmission:

1. Configure the SCI:
 - a) Select a baud rate. Write this value to the SCI baud registers (SCIBDH/L) to begin the baud rate generator. Remember that the baud rate generator is disabled when the baud rate is 0. Writing to the SCIBDH has no effect without also writing to SCIBDL.
 - b) Write to SCICR1 to configure word length, parity, and other configuration bits (LOOPS, RSRC, M, WAKE, ILT, PE, and PT).
 - c) Enable the transmitter, interrupts, receive, and wake up as required, by writing to the SCICR2 register bits (TIE, TCIE, RIE, ILIE, TE, RE, RWU, and SBK). A preamble or idle character will now be shifted out of the transmitter shift register.
2. Transmit procedure for each byte:
 - a) Poll the TDRE flag by reading the SCISR1 or responding to the TDRE interrupt. Keep in mind that the TDRE bit resets to 1.
 - b) If the TDRE flag is set, write the data to be transmitted to SCIDRH/L, where the ninth bit is written to the T8 bit in SCIDRH if the SCI is in 9-bit data format. A new transmission will not result until the TDRE flag has been cleared.
3. Repeat step 2 for each subsequent transmission.

NOTE

The TDRE flag is set when the shift register is loaded with the next data to be transmitted from SCIDRH/L, which happens, generally speaking, a little over half-way through the stop bit of the previous frame. Specifically, this transfer occurs 9/16ths of a bit time AFTER the start of the stop bit of the previous frame.

Writing the TE bit from 0 to a 1 automatically loads the transmit shift register with a preamble of 10 logic 1s (if M = 0) or 11 logic 1s (if M = 1). After the preamble shifts out, control logic transfers the data from the SCI data register into the transmit shift register. A logic 0 start bit automatically goes into the least significant bit position of the transmit shift register. A logic 1 stop bit goes into the most significant bit position.

Hardware supports odd or even parity. When parity is enabled, the most significant bit (MSB) of the data character is the parity bit.

The transmit data register empty flag, TDRE, in SCI status register 1 (SCISR1) becomes set when the SCI data register transfers a byte to the transmit shift register. The TDRE flag indicates that the SCI data register can accept new data from the internal data bus. If the transmit interrupt enable bit, TIE, in SCI control register 2 (SCICR2) is also set, the TDRE flag generates a transmitter interrupt request.

When the transmit shift register is not transmitting a frame, the TXD pin goes to the idle condition, logic 1. If at any time software clears the TE bit in SCI control register 2 (SCICR2), the transmitter enable signal goes low and the transmit signal goes idle.

If software clears TE while a transmission is in progress ($TC = 0$), the frame in the transmit shift register continues to shift out. To avoid accidentally cutting off the last frame in a message, always wait for TDRE to go high after the last frame before clearing TE.

To separate messages with preambles with minimum idle line time, use this sequence between messages:

1. Write the last byte of the first message to SCIDRH/L.
2. Wait for the TDRE flag to go high, indicating the transfer of the last frame to the transmit shift register.
3. Queue a preamble by clearing and then setting the TE bit.
4. Write the first byte of the second message to SCIDRH/L.

8.5.4.3 Break Characters

Writing a logic 1 to the send break bit, SBK, in SCI control register 2 (SCICR2) loads the transmit shift register with a break character. A break character contains all logic 0s and has no start, stop, or parity bit. Break character length depends on the M bit in SCI control register 1 (SCICR1). As long as SBK is at logic 1, transmitter logic continuously loads break characters into the transmit shift register. After software clears the SBK bit, the shift register finishes transmitting the last break character and then transmits at least one logic 1. The automatic logic 1 at the end of a break character guarantees the recognition of the start bit of the next frame.

The SCI recognizes a break character when a start bit is followed by eight or nine logic 0 data bits and a logic 0 where the stop bit should be. Receiving a break character has these effects on SCI registers:

- Sets the framing error flag, FE
- Sets the receive data register full flag, RDRF
- Clears the SCI data registers (SCIDRH/L)
- May set the overrun flag, OR, noise flag, NF, parity error flag, PE, or the receiver active flag, RAF (see [Section 8.4.2.4, “SCI Status Register 1 \(SCISR1\)”](#) and [Section 8.4.2.5, “SCI Status Register 2 \(SCISR2\)”](#)).

8.5.4.4 Idle Characters

An idle character (or preamble) contains all logic 1s and has no start, stop, or parity bit. Idle character length depends on the M bit in SCI control register 1 (SCICR1). The preamble is a synchronizing idle character that begins the first transmission initiated after writing the TE bit from 0 to 1.

If the TE bit is cleared during a transmission, the TXD pin becomes idle after completion of the transmission in progress. Clearing and then setting the TE bit during a transmission queues an idle character to be sent after the frame currently being transmitted.

NOTE

When queueing an idle character, return the TE bit to logic 1 before the stop bit of the current frame shifts out through the TXD pin. Setting TE after the stop bit appears on TXD causes data previously written to the SCI data register to be lost. Toggle the TE bit for a queued idle character while the

TDRE flag is set and immediately before writing the next byte to the SCI data register.

If the TE bit is clear and the transmission is complete, the SCI is not the master of the TXD pin

8.5.5 Receiver

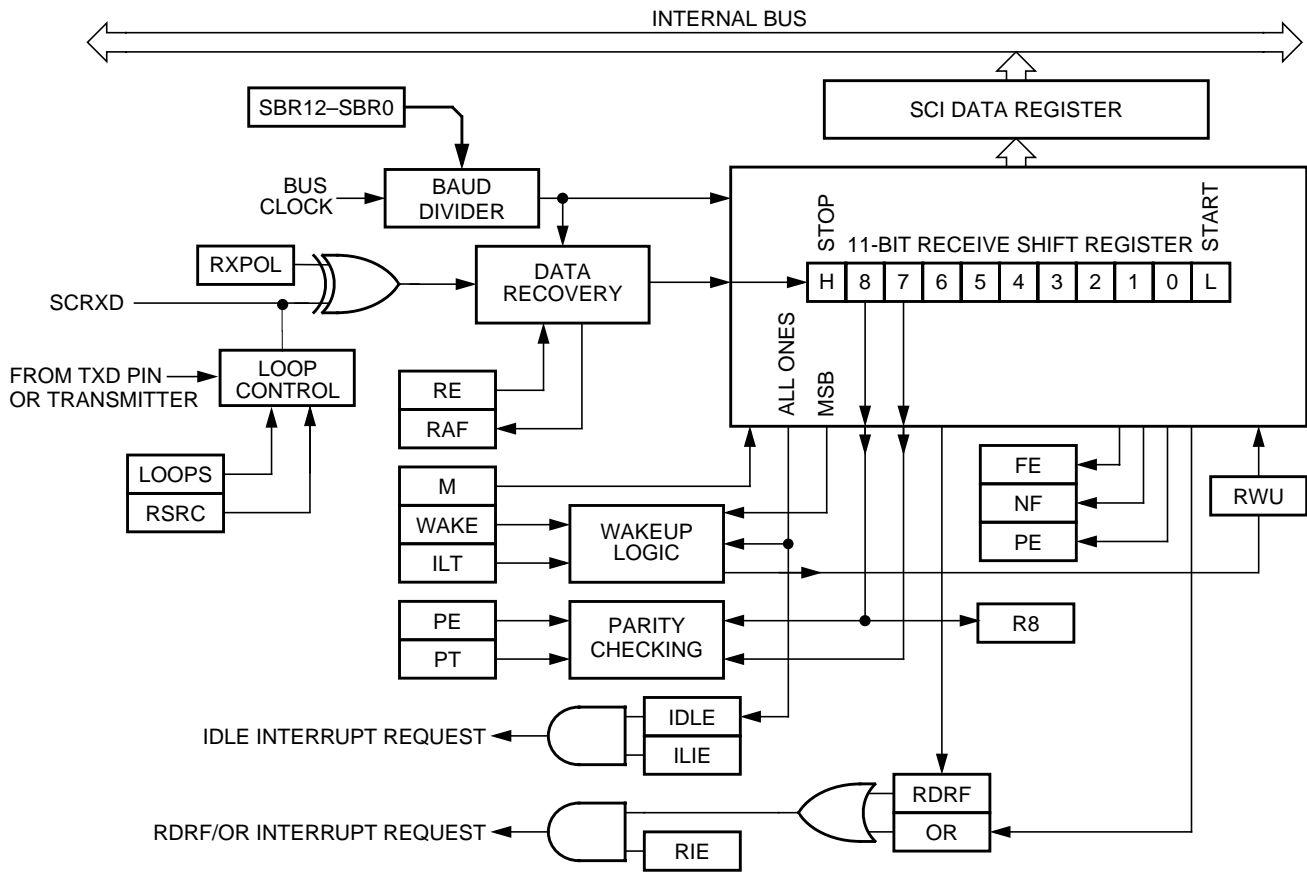

Figure 8-14. SCI Receiver Block Diagram

8.5.5.1 Receiver Character Length

The SCI receiver can accommodate either 8-bit or 9-bit data characters. The state of the M bit in SCI control register 1 (SCICR1) determines the length of data characters. When receiving 9-bit data, bit R8 in SCI data register high (SCIDRH) is the ninth bit (bit 8).

8.5.5.2 Character Reception

During an SCI reception, the receive shift register shifts a frame in from the RXD pin. The SCI data register is the read-only buffer between the internal data bus and the receive shift register.

After a complete frame shifts into the receive shift register, the data portion of the frame transfers to the SCI data register. The receive data register full flag, RDRF, in SCI status register 1 (SCISR1) becomes set,

indicating that the received byte can be read. If the receive interrupt enable bit, RIE, in SCI control register 2 (SCICR2) is also set, the RDRF flag generates an RDRF interrupt request.

8.5.5.3 Data Sampling

The receiver samples the RXD pin at the RT clock rate. The RT clock is an internal signal with a frequency 16 times the baud rate. To adjust for baud rate mismatch, the RT clock (see [Figure 8-15](#)) is re-synchronized:

- After every start bit
- After the receiver detects a data bit change from logic 1 to logic 0 (after the majority of data bit samples at RT8, RT9, and RT10 returns a valid logic 1 and the majority of the next RT8, RT9, and RT10 samples returns a valid logic 0)

To locate the start bit, data recovery logic does an asynchronous search for a logic 0 preceded by three logic 1s. When the falling edge of a possible start bit occurs, the RT clock begins to count to 16.

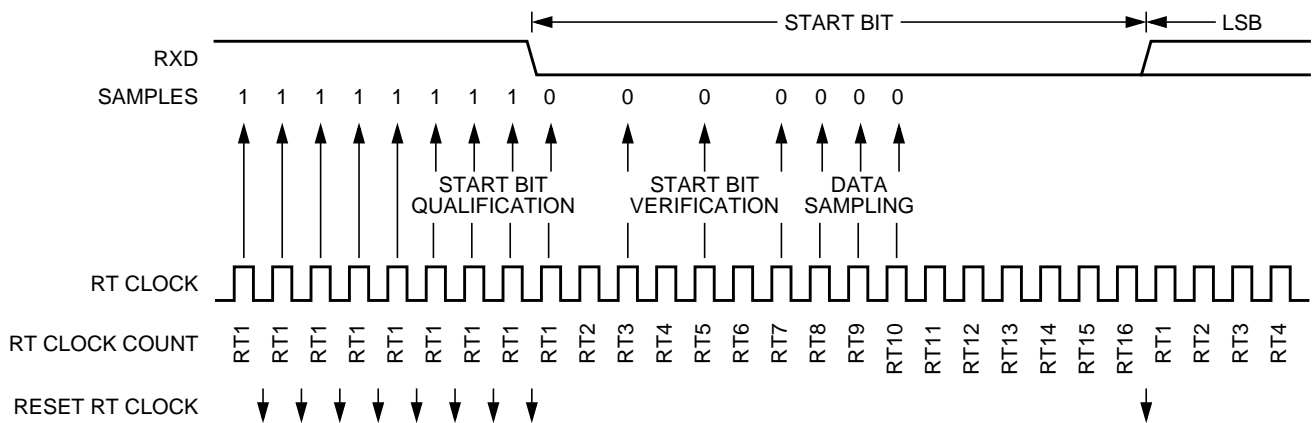

Figure 8-15. Receiver Data Sampling

To verify the start bit and to detect noise, data recovery logic takes samples at RT3, RT5, and RT7. [Table 8-15](#) summarizes the results of the start bit verification samples.

Table 8-15. Start Bit Verification

RT3, RT5, and RT7 Samples	Start Bit Verification	Noise Flag
000	Yes	0
001	Yes	1
010	Yes	1
011	No	0
100	Yes	1
101	No	0
110	No	0
111	No	0

If start bit verification is not successful, the RT clock is reset and a new search for a start bit begins.

To determine the value of a data bit and to detect noise, recovery logic takes samples at RT8, RT9, and RT10. [Table 8-16](#) summarizes the results of the data bit samples.

Table 8-16. Data Bit Recovery

RT8, RT9, and RT10 Samples	Data Bit Determination	Noise Flag
000	0	0
001	0	1
010	0	1
011	1	1
100	0	1
101	1	1
110	1	1
111	1	0

NOTE

The RT8, RT9, and RT10 samples do not affect start bit verification. If any or all of the RT8, RT9, and RT10 start bit samples are logic 1s following a successful start bit verification, the noise flag (NF) is set and the receiver assumes that the bit is a start bit (logic 0).

To verify a stop bit and to detect noise, recovery logic takes samples at RT8, RT9, and RT10. [Table 8-17](#) summarizes the results of the stop bit samples.

Table 8-17. Stop Bit Recovery

RT8, RT9, and RT10 Samples	Framing Error Flag	Noise Flag
000	1	0
001	1	1
010	1	1
011	0	1
100	1	1
101	0	1
110	0	1
111	0	0

In [Figure 8-16](#) the verification samples RT3 and RT5 determine that the first low detected was noise and not the beginning of a start bit. The RT clock is reset and the start bit search begins again. The noise flag is not set because the noise occurred before the start bit was found.

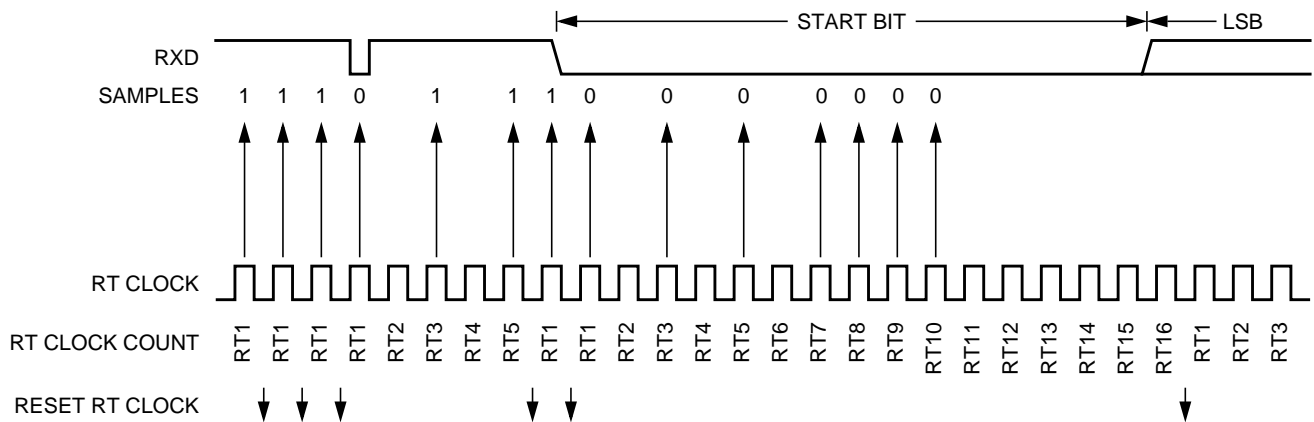

Figure 8-16. Start Bit Search Example 1

In [Figure 8-17](#), verification sample at RT3 is high. The RT3 sample sets the noise flag. Although the perceived bit time is misaligned, the data samples RT8, RT9, and RT10 are within the bit time and data recovery is successful.

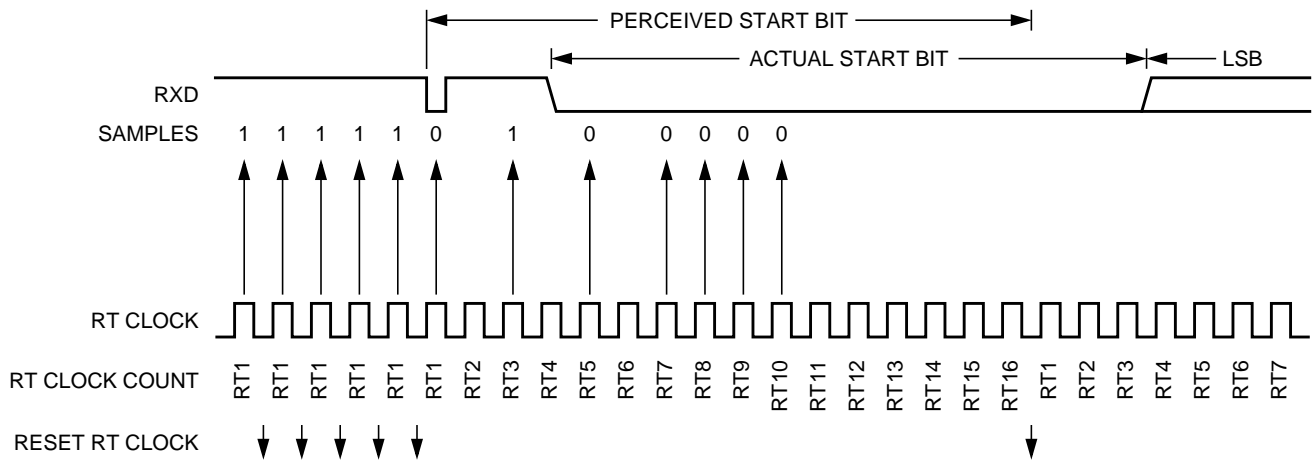

Figure 8-17. Start Bit Search Example 2

In [Figure 8-18](#), a large burst of noise is perceived as the beginning of a start bit, although the test sample at RT5 is high. The RT5 sample sets the noise flag. Although this is a worst-case misalignment of perceived bit time, the data samples RT8, RT9, and RT10 are within the bit time and data recovery is successful.

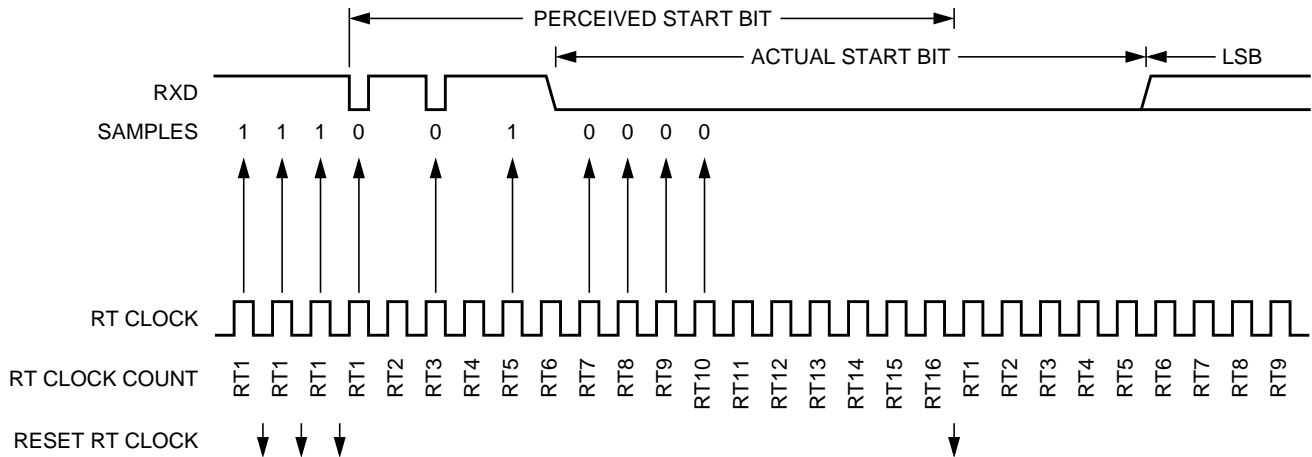

Figure 8-18. Start Bit Search Example 3

[Figure 8-19](#) shows the effect of noise early in the start bit time. Although this noise does not affect proper synchronization with the start bit time, it does set the noise flag.

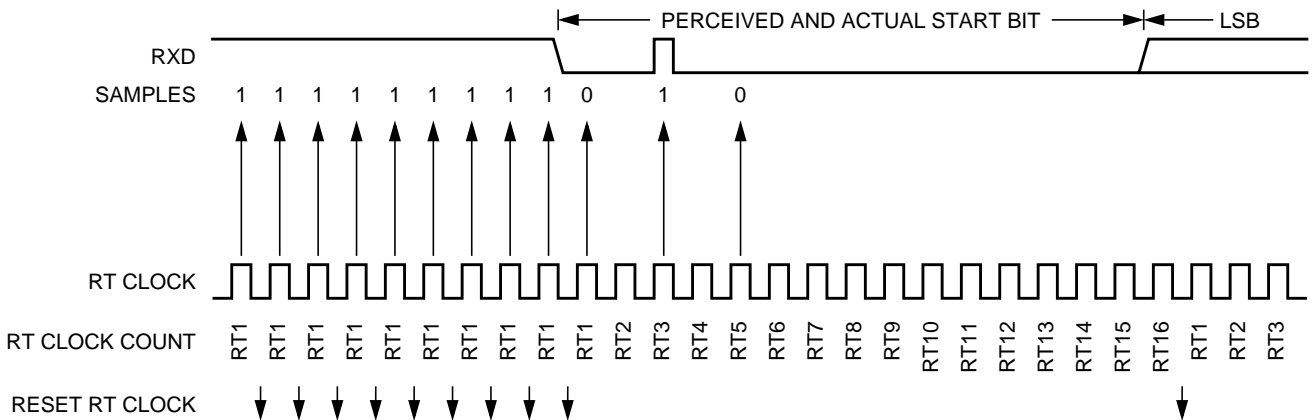

Figure 8-19. Start Bit Search Example 4

Figure 8-20 shows a burst of noise near the beginning of the start bit that resets the RT clock. The sample after the reset is low but is not preceded by three high samples that would qualify as a falling edge. Depending on the timing of the start bit search and on the data, the frame may be missed entirely or it may set the framing error flag.

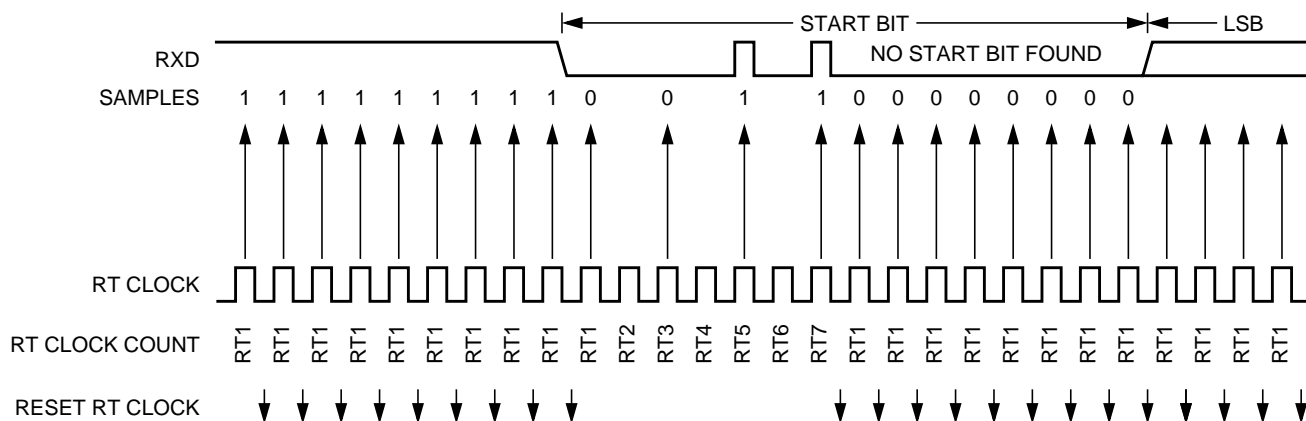

Figure 8-20. Start Bit Search Example 5

In Figure 8-21, a noise burst makes the majority of data samples RT8, RT9, and RT10 high. This sets the noise flag but does not reset the RT clock. In start bits only, the RT8, RT9, and RT10 data samples are ignored.

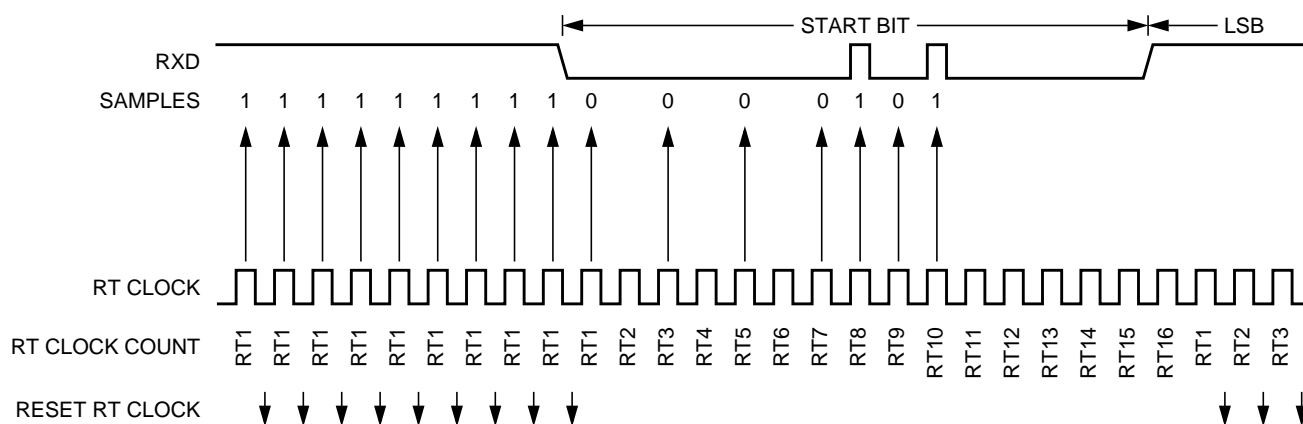

Figure 8-21. Start Bit Search Example 6

8.5.5.4 Framing Errors

If the data recovery logic does not detect a logic 1 where the stop bit should be in an incoming frame, it sets the framing error flag, FE, in SCI status register 1 (SCISR1). A break character also sets the FE flag because a break character has no stop bit. The FE flag is set at the same time that the RDRF flag is set.

8.5.5.5 Baud Rate Tolerance

A transmitting device may be operating at a baud rate below or above the receiver baud rate. Accumulated bit time misalignment can cause one of the three stop bit data samples (RT8, RT9, and RT10) to fall outside the actual stop bit. A noise error will occur if the RT8, RT9, and RT10 samples are not all the same logical values. A framing error will occur if the receiver clock is misaligned in such a way that the majority of the RT8, RT9, and RT10 stop bit samples are a logic 0.

As the receiver samples an incoming frame, it re-synchronizes the RT clock on any valid falling edge within the frame. Re synchronization within frames will correct a misalignment between transmitter bit times and receiver bit times.

8.5.5.5.1 Slow Data Tolerance

Figure 8-22 shows how much a slow received frame can be misaligned without causing a noise error or a framing error. The slow stop bit begins at RT8 instead of RT1 but arrives in time for the stop bit data samples at RT8, RT9, and RT10.

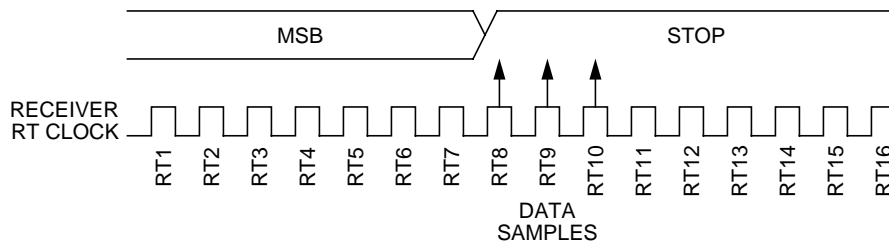

Figure 8-22. Slow Data

Let's take RTr as receiver RT clock and RTt as transmitter RT clock.

For an 8-bit data character, it takes the receiver 9 bit times x 16 RTr cycles + 7 RTr cycles = 151 RTr cycles to start data sampling of the stop bit.

With the misaligned character shown in Figure 8-22, the receiver counts 151 RTr cycles at the point when the count of the transmitting device is 9 bit times x 16 RTt cycles = 144 RTt cycles.

The maximum percent difference between the receiver count and the transmitter count of a slow 8-bit data character with no errors is:

$$((151 - 144) / 151) \times 100 = 4.63\%$$

For a 9-bit data character, it takes the receiver 10 bit times x 16 RTr cycles + 7 RTr cycles = 167 RTr cycles to start data sampling of the stop bit.

With the misaligned character shown in Figure 8-22, the receiver counts 167 RTr cycles at the point when the count of the transmitting device is 10 bit times x 16 RTt cycles = 160 RTt cycles.

The maximum percent difference between the receiver count and the transmitter count of a slow 9-bit character with no errors is:

$$((167 - 160) / 167) \times 100 = 4.19\%$$

8.5.5.2 Fast Data Tolerance

Figure 8-23 shows how much a fast received frame can be misaligned. The fast stop bit ends at RT10 instead of RT16 but continues to be sampled at RT8, RT9, and RT10.

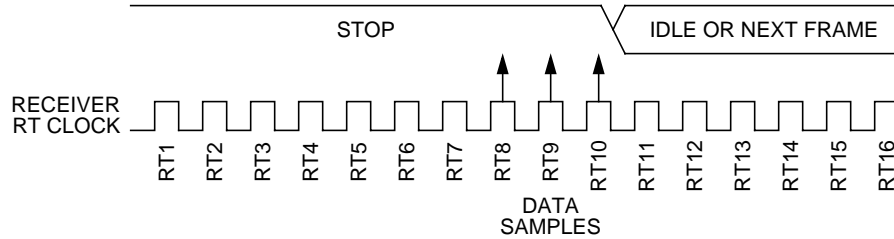

Figure 8-23. Fast Data

For an 8-bit data character, it takes the receiver 9 bit times \times 16 RTr cycles + 10 RTr cycles = 154 RTr cycles to finish data sampling of the stop bit.

With the misaligned character shown in Figure 8-23, the receiver counts 154 RTr cycles at the point when the count of the transmitting device is 10 bit times \times 16 RTt cycles = 160 RTt cycles.

The maximum percent difference between the receiver count and the transmitter count of a fast 8-bit character with no errors is:

$$((160 - 154) / 160) \times 100 = 3.75\%$$

For a 9-bit data character, it takes the receiver 10 bit times \times 16 RTr cycles + 10 RTr cycles = 170 RTr cycles to finish data sampling of the stop bit.

With the misaligned character shown in Figure 8-23, the receiver counts 170 RTr cycles at the point when the count of the transmitting device is 11 bit times \times 16 RTt cycles = 176 RTt cycles.

The maximum percent difference between the receiver count and the transmitter count of a fast 9-bit character with no errors is:

$$((176 - 170) / 176) \times 100 = 3.40\%$$

8.5.5.6 Receiver Wakeup

To enable the SCI to ignore transmissions intended only for other receivers in multiple-receiver systems, the receiver can be put into a standby state. Setting the receiver wakeup bit, RWU, in SCI control register 2 (SCICR2) puts the receiver into standby state during which receiver interrupts are disabled. The SCI will continue to load the receive data into the SCIDRH/L registers, but it will not set the RDRF flag.

The transmitting device can address messages to selected receivers by including addressing information in the initial frame or frames of each message.

The WAKE bit in SCI control register 1 (SCICR1) determines how the SCI is brought out of the standby state to process an incoming message. The WAKE bit enables either idle line wakeup or address mark wakeup.

8.5.5.6.1 Idle Input Line Wakeup (WAKE = 0)

In this wakeup method, an idle condition on the RXD pin clears the RWU bit and wakes up the SCI. The initial frame or frames of every message contain addressing information. All receivers evaluate the addressing information, and receivers for which the message is addressed process the frames that follow. Any receiver for which a message is not addressed can set its RWU bit and return to the standby state. The RWU bit remains set and the receiver remains on standby until another idle character appears on the RXD pin.

Idle line wakeup requires that messages be separated by at least one idle character and that no message contains idle characters.

The idle character that wakes a receiver does not set the receiver idle bit, IDLE, or the receive data register full flag, RDRF.

The idle line type bit, ILT, determines whether the receiver begins counting logic 1s as idle character bits after the start bit or after the stop bit. ILT is in SCI control register 1 (SCICR1).

8.5.5.6.2 Address Mark Wakeup (WAKE = 1)

In this wakeup method, a logic 1 in the most significant bit (MSB) position of a frame clears the RWU bit and wakes up the SCI. The logic 1 in the MSB position marks a frame as an address frame that contains addressing information. All receivers evaluate the addressing information, and the receivers for which the message is addressed process the frames that follow. Any receiver for which a message is not addressed can set its RWU bit and return to the standby state. The RWU bit remains set and the receiver remains on standby until another address frame appears on the RXD pin.

The logic 1 MSB of an address frame clears the receiver's RWU bit before the stop bit is received and sets the RDRF flag.

Address mark wakeup allows messages to contain idle characters but requires that the MSB be reserved for use in address frames.

NOTE

With the WAKE bit clear, setting the RWU bit after the RXD pin has been idle can cause the receiver to wake up immediately.

8.5.6 Single-Wire Operation

Normally, the SCI uses two pins for transmitting and receiving. In single-wire operation, the RXD pin is disconnected from the SCI. The SCI uses the TXD pin for both receiving and transmitting.

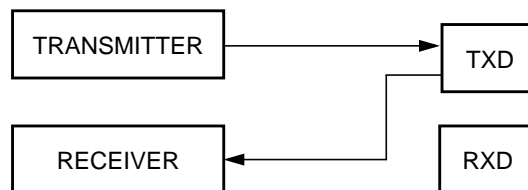

Figure 8-24. Single-Wire Operation (LOOPS = 1, RSRC = 1)

Enable single-wire operation by setting the LOOPS bit and the receiver source bit, RSRC, in SCI control register 1 (SCICR1). Setting the LOOPS bit disables the path from the RXD pin to the receiver. Setting the RSRC bit connects the TXD pin to the receiver. Both the transmitter and receiver must be enabled (TE = 1 and RE = 1). The TXDIR bit (SCISR2[1]) determines whether the TXD pin is going to be used as an input (TXDIR = 0) or an output (TXDIR = 1) in this mode of operation.

NOTE

In single-wire operation data from the TXD pin is inverted if RXPOL is set.

8.5.7 Loop Operation

In loop operation the transmitter output goes to the receiver input. The RXD pin is disconnected from the SCI

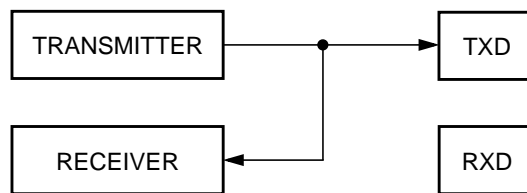

Figure 8-25. Loop Operation (LOOPS = 1, RSRC = 0)

Enable loop operation by setting the LOOPS bit and clearing the RSRC bit in SCI control register 1 (SCICR1). Setting the LOOPS bit disables the path from the RXD pin to the receiver. Clearing the RSRC bit connects the transmitter output to the receiver input. Both the transmitter and receiver must be enabled (TE = 1 and RE = 1).

NOTE

In loop operation data from the transmitter is not recognized by the receiver if RXPOL and TXPOL are not the same.

8.6 Interrupts

This section describes the interrupt originated by the SCI block. The MCU must service the interrupt requests. Table 8-18 lists the five interrupt sources of the SCI.

Table 8-18. SCI Interrupt Sources

Interrupt	Source	Local Enable	Description
TDRE	SCISR1[7]	TIE	Active high level. Indicates that a byte was transferred from SCIDRH/L to the transmit shift register.
TC	SCISR1[6]	TCIE	Active high level. Indicates that a transmit is complete.
RDRF	SCISR1[5]	RIE	Active high level. The RDRF interrupt indicates that received data is available in the SCI data register.
OR	SCISR1[3]		Active high level. This interrupt indicates that an overrun condition has occurred.

Table 8-18. SCI Interrupt Sources

IDLE	SCISR1[4]	ILIE	Active high level. Indicates that receiver input has become idle.
------	-----------	------	---

8.6.1 Description of Interrupt Operation

The SCI only originates interrupt requests. The following is a description of how the SCI makes a request and how the MCU should acknowledge that request. The interrupt vector offset and interrupt number are chip dependent. The SCI only has a single interrupt line (SCI interrupt signal, active high operation) and all the following interrupts, when generated, are ORed together and issued through that port.

8.6.1.1 TDRE Description

The TDRE interrupt is set high by the SCI when the transmit shift register receives a byte from the SCI data register. A TDRE interrupt indicates that the transmit data register (SCIDRH/L) is empty and that a new byte can be written to the SCIDRH/L for transmission. Clear TDRE by reading SCI status register 1 with TDRE set and then writing to SCI data register low (SCIDRL).

8.6.1.2 TC Description

The TC interrupt is set by the SCI when a transmission has been completed. A TC interrupt indicates that there is no transmission in progress. TC is set high when the TDRE flag is set and no data, preamble, or break character is being transmitted. When TC is set, the TXD pin becomes idle (logic 1). Clear TC by reading SCI status register 1 (SCISR1) with TC set and then writing to SCI data register low (SCIDRL). TC is cleared automatically when data, preamble, or break is queued and ready to be sent.

8.6.1.3 RDRF Description

The RDRF interrupt is set when the data in the receive shift register transfers to the SCI data register. A RDRF interrupt indicates that the received data has been transferred to the SCI data register and that the byte can now be read by the MCU. The RDRF interrupt is cleared by reading the SCI status register one (SCISR1) and then reading SCI data register low (SCIDRL).

8.6.1.4 OR Description

The OR interrupt is set when software fails to read the SCI data register before the receive shift register receives the next frame. The newly acquired data in the shift register will be lost in this case, but the data already in the SCI data registers is not affected. The OR interrupt is cleared by reading the SCI status register one (SCISR1) and then reading SCI data register low (SCIDRL).

8.6.1.5 IDLE Description

The IDLE interrupt is set when 10 consecutive logic 1s (if M = 0) or 11 consecutive logic 1s (if M = 1) appear on the receiver input. After the IDLE is cleared, a valid frame must again set the RDRF flag before an idle condition can set the IDLE flag. Clear IDLE by reading SCI status register 1 (SCISR1) with IDLE set and then reading SCI data register low (SCIDRL).

8.6.2 Recovery from Wait Mode

The SCI interrupt request can be used to bring the CPU out of wait mode.

Chapter 9

Serial Peripheral Interface (SPIV3) Block Description

9.1 Introduction

The SPI module allows a duplex, synchronous, serial communication between the MCU and peripheral devices. Software can poll the SPI status flags or the SPI operation can be interrupt driven.

9.1.1 Features

The SPIV3 includes these distinctive features:

- Master mode and slave mode
- Bidirectional mode
- Slave select output
- Mode fault error flag with CPU interrupt capability
- Double-buffered data register
- Serial clock with programmable polarity and phase
- Control of SPI operation during wait mode

9.1.2 Modes of Operation

The SPI functions in three modes, run, wait, and stop.

- Run Mode
This is the basic mode of operation.
- Wait Mode
SPI operation in wait mode is a configurable low power mode, controlled by the SPISWAI bit located in the SPICR2 register. In wait mode, if the SPISWAI bit is clear, the SPI operates like in Run Mode. If the SPISWAI bit is set, the SPI goes into a power conservative state, with the SPI clock generation turned off. If the SPI is configured as a master, any transmission in progress stops, but is resumed after CPU goes into Run Mode. If the SPI is configured as a slave, reception and transmission of a byte continues, so that the slave stays synchronized to the master.
- Stop Mode
The SPI is inactive in stop mode for reduced power consumption. If the SPI is configured as a master, any transmission in progress stops, but is resumed after CPU goes into run mode. If the SPI is configured as a slave, reception and transmission of a byte continues, so that the slave stays synchronized to the master.

This is a high level description only, detailed descriptions of operating modes are contained in [Section 9.4, “Functional Description.”](#)

9.1.3 Block Diagram

Figure 9-1 gives an overview on the SPI architecture. The main parts of the SPI are status, control, and data registers, shifter logic, baud rate generator, master/slave control logic, and port control logic.

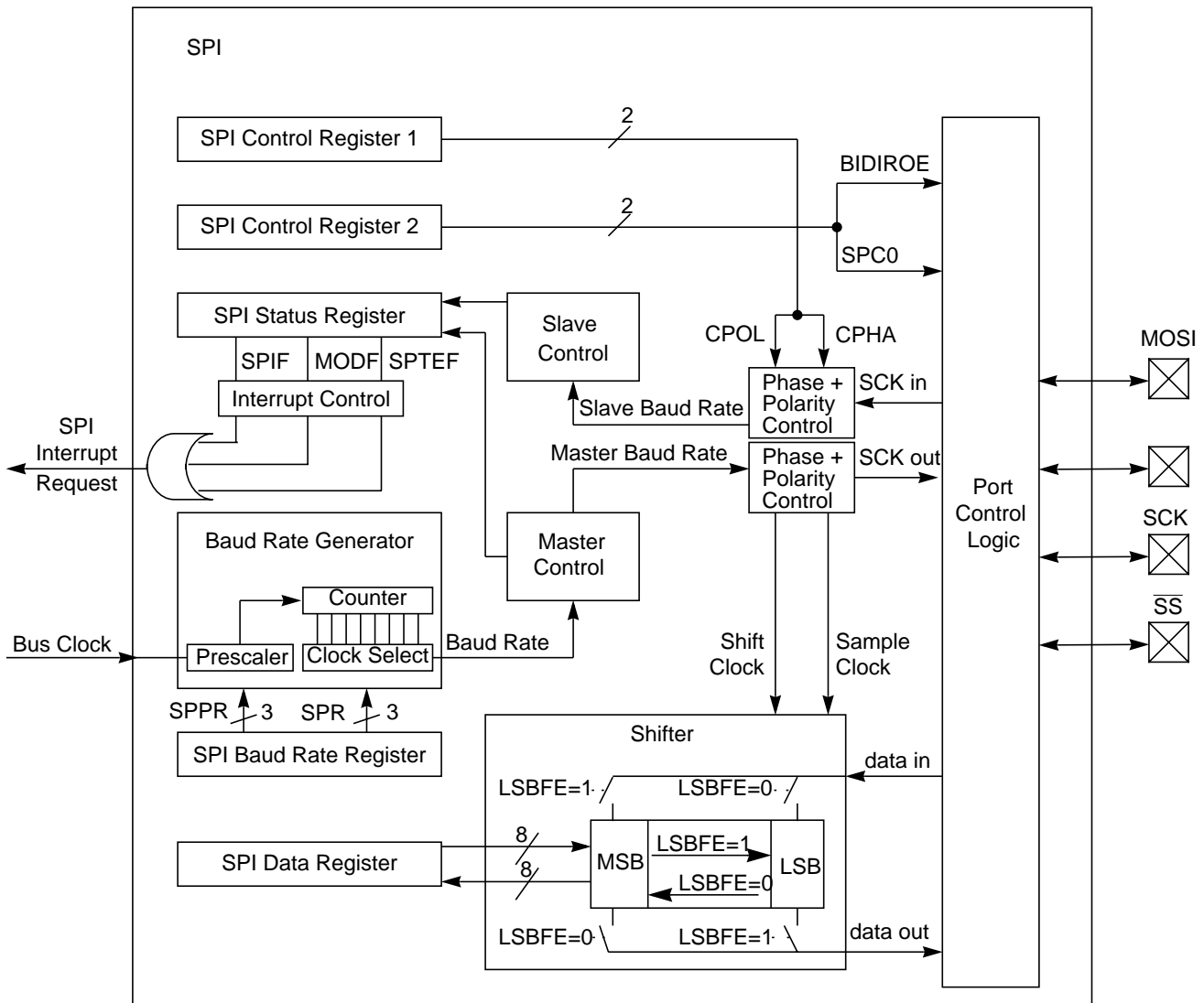

Figure 9-1. SPI Block Diagram

9.2 External Signal Description

This section lists the name and description of all ports including inputs and outputs that do, or may, connect off chip. The SPIV3 module has a total of four external pins.

9.2.1 MOSI — Master Out/Slave In Pin

This pin is used to transmit data out of the SPI module when it is configured as a master and receive data when it is configured as slave.

9.2.2 MISO — Master In/Slave Out Pin

This pin is used to transmit data out of the SPI module when it is configured as a slave and receive data when it is configured as master.

9.2.3 \overline{SS} — Slave Select Pin

This pin is used to output the select signal from the SPI module to another peripheral with which a data transfer is to take place when its configured as a master and its used as an input to receive the slave select signal when the SPI is configured as slave.

9.2.4 SCK — Serial Clock Pin

This pin is used to output the clock with respect to which the SPI transfers data or receive clock in case of slave.

9.3 Memory Map and Register Definition

This section provides a detailed description of address space and registers used by the SPI.

The memory map for the SPIV3 is given below in [Table 9-1](#). The address listed for each register is the sum of a base address and an address offset. The base address is defined at the SoC level and the address offset is defined at the module level. Reads from the reserved bits return zeros and writes to the reserved bits have no effect.

9.3.1 Module Memory Map

Table 9-1. SPIV3 Memory Map

Address	Use	Access
0x0000	SPI Control Register 1 (SPICR1)	R/W
0x0001	SPI Control Register 2 (SPICR2)	R/W ¹
0x0002	SPI Baud Rate Register (SPIBR)	R/W ¹
0x0003	SPI Status Register (SPISR)	R ²
0x0004	Reserved	— ^{2,3}
0x0005	SPI Data Register (SPIDR)	R/W
0x0006	Reserved	— ^{2,3}
0x0007	Reserved	— ^{2,3}

¹ Certain bits are non-writable.

² Writes to this register are ignored.

³ Reading from this register returns all zeros.

9.3.2 Register Descriptions

This section consists of register descriptions in address order. Each description includes a standard register diagram with an associated figure number. Details of register bit and field function follow the register diagrams, in bit order.

Name		7	6	5	4	3	2	1	0
0x0000 SPICR1	R W	SPIE	SPE	SPTIE	MSTR	CPOL	CPHA	SSOE	LSBFE
0x0001 SPICR2	R W	0	0	0	MODFEN	BIDIROE	0	SPISWAI	SPC0
0x0002 SPIBR	R W	0	SPPR2	SPPR1	SPPR0	0	SPR2	SPR1	SPR0
0x0003 SPISR	R W	SPIF	0	SPTIEF	MODF	0	0	0	0
0x0004 Reserved	R W								
0x0005 SPIDR	R W	Bit 7	6	5	4	3	2	2	Bit 0
0x0006 Reserved	R W								
0x0007 Reserved	R W								

= Unimplemented or Reserved

Figure 9-2. SPI Register Summary

9.3.2.1 SPI Control Register 1 (SPICR1)

Module Base 0x0000

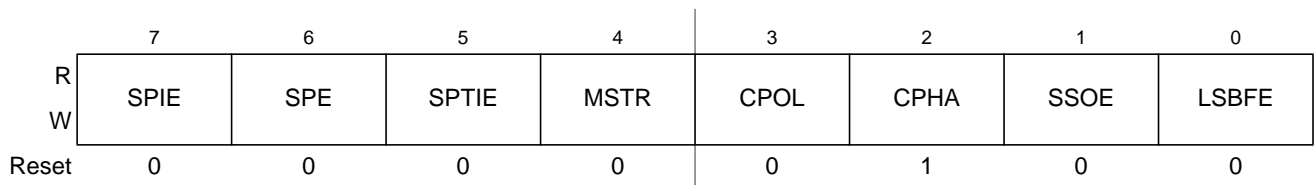

Figure 9-3. SPI Control Register 1 (SPICR1)

Read: anytime

Write: anytime

Table 9-2. SPICR1 Field Descriptions

Field	Description
7 SPIE	SPI Interrupt Enable Bit — This bit enables SPI interrupt requests, if SPIF or MODF status flag is set. 0 SPI interrupts disabled. 1 SPI interrupts enabled.
6 SPE	SPI System Enable Bit — This bit enables the SPI system and dedicates the SPI port pins to SPI system functions. If SPE is cleared, SPI is disabled and forced into idle state, status bits in SPISR register are reset. 0 SPI disabled (lower power consumption). 1 SPI enabled, port pins are dedicated to SPI functions.
5 SPTIE	SPI Transmit Interrupt Enable — This bit enables SPI interrupt requests, if SPTEF flag is set. 0 SPTEF interrupt disabled. 1 SPTEF interrupt enabled.
4 MSTR	SPI Master/Slave Mode Select Bit — This bit selects, if the SPI operates in master or slave mode. Switching the SPI from master to slave or vice versa forces the SPI system into idle state. 0 SPI is in slave mode 1 SPI is in master mode
3 CPOL	SPI Clock Polarity Bit — This bit selects an inverted or non-inverted SPI clock. To transmit data between SPI modules, the SPI modules must have identical CPOL values. In master mode, a change of this bit will abort a transmission in progress and force the SPI system into idle state. 0 Active-high clocks selected. In idle state SCK is low. 1 Active-low clocks selected. In idle state SCK is high.
2 CPHA	SPI Clock Phase Bit — This bit is used to select the SPI clock format. In master mode, a change of this bit will abort a transmission in progress and force the SPI system into idle state. 0 Sampling of data occurs at odd edges (1,3,5,...,15) of the SCK clock 1 Sampling of data occurs at even edges (2,4,6,...,16) of the SCK clock
1 SSOE	Slave Select Output Enable — The \overline{SS} output feature is enabled only in master mode, if MODFEN is set, by asserting the SSOE as shown in Table 9-3 . In master mode, a change of this bit will abort a transmission in progress and force the SPI system into idle state.
0 LSBFE	LSB-First Enable — This bit does not affect the position of the MSB and LSB in the data register. Reads and writes of the data register always have the MSB in bit 7. In master mode, a change of this bit will abort a transmission in progress and force the SPI system into idle state. 0 Data is transferred most significant bit first. 1 Data is transferred least significant bit first.

Table 9-3. \overline{SS} Input / Output Selection

MODFEN	SSOE	Master Mode	Slave Mode
0	0	\overline{SS} not used by SPI	\overline{SS} input
0	1	\overline{SS} not used by SPI	\overline{SS} input
1	0	\overline{SS} input with MODF feature	\overline{SS} input
1	1	\overline{SS} is slave select output	\overline{SS} input

9.3.2.2 SPI Control Register 2 (SPICR2)

Module Base 0x0001

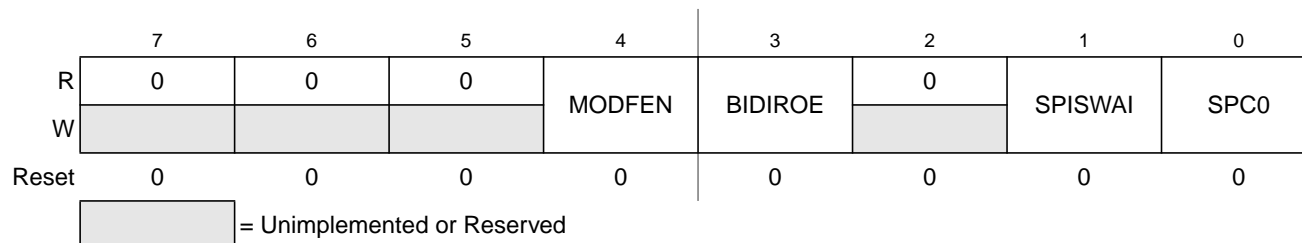

Figure 9-4. SPI Control Register 2 (SPICR2)

Read: anytime

Write: anytime; writes to the reserved bits have no effect

Table 9-4. SPICR2 Field Descriptions

Field	Description
4 MODFEN	Mode Fault Enable Bit — This bit allows the MODF failure being detected. If the SPI is in master mode and MODFEN is cleared, then the SS port pin is not used by the SPI. In slave mode, the SS is available only as an input regardless of the value of MODFEN. For an overview on the impact of the MODFEN bit on the SS port pin configuration refer to Table 9-3 . In master mode, a change of this bit will abort a transmission in progress and force the SPI system into idle state. 0 SS port pin is not used by the SPI 1 SS port pin with MODF feature
3 BIDIROE	Output Enable in the Bidirectional Mode of Operation — This bit controls the MOSI and MISO output buffer of the SPI, when in bidirectional mode of operation (SPC0 is set). In master mode this bit controls the output buffer of the MOSI port, in slave mode it controls the output buffer of the MISO port. In master mode, with SPC0 set, a change of this bit will abort a transmission in progress and force the SPI into idle state. 0 Output buffer disabled 1 Output buffer enabled
1 SPISWAI	SPI Stop in Wait Mode Bit — This bit is used for power conservation while in wait mode. 0 SPI clock operates normally in wait mode 1 Stop SPI clock generation when in wait mode
0 SPC0	Serial Pin Control Bit 0 — This bit enables bidirectional pin configurations as shown in Table 9-5 . In master mode, a change of this bit will abort a transmission in progress and force the SPI system into idle state

Table 9-5. Bidirectional Pin Configurations

Pin Mode	SPC0	BIDIROE	MISO	MOSI
Master Mode of Operation				
Normal	0	X	Master In	Master Out
Bidirectional	1	0	MISO not used by SPI	Master In
		1		Master I/O
Slave Mode of Operation				
Normal	0	X	Slave Out	Slave In

Table 9-5. Bidirectional Pin Configurations (continued)

Pin Mode	SPC0	BIDIROE	MISO	MOSI
Bidirectional	1	0	Slave In	MOSI not used by SPI
		1	Slave I/O	

9.3.2.3 SPI Baud Rate Register (SPIBR)

Module Base 0x0002

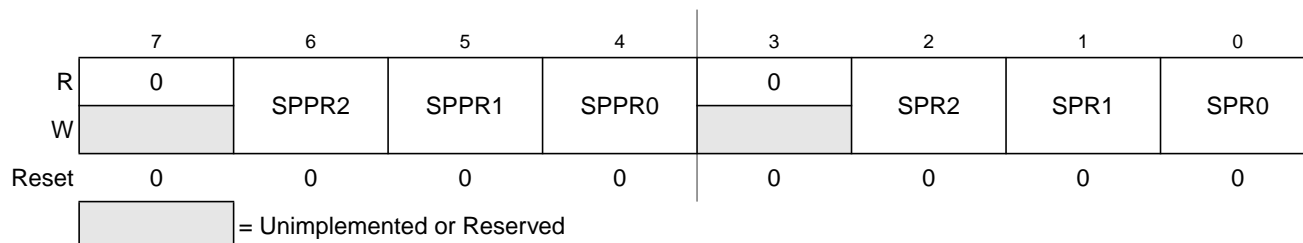
Figure 9-5. SPI Baud Rate Register (SPIBR)

Read: anytime

Write: anytime; writes to the reserved bits have no effect

Table 9-6. SPIBR Field Descriptions

Field	Description
6:4 SPPR[2:0]	SPI Baud Rate Preselection Bits — These bits specify the SPI baud rates as shown in Table 9-7 . In master mode, a change of these bits will abort a transmission in progress and force the SPI system into idle state.
2:0 SPR[2:0]	SPI Baud Rate Selection Bits — These bits specify the SPI baud rates as shown in Table 9-7 . In master mode, a change of these bits will abort a transmission in progress and force the SPI system into idle state.

The baud rate divisor equation is as follows:

$$\text{BaudRateDivisor} = (\text{SPPR} + 1) \cdot 2^{(\text{SPR} + 1)}$$

The baud rate can be calculated with the following equation:

$$\text{Baud Rate} = \text{BusClock} / \text{BaudRateDivisor}$$

Table 9-7. Example SPI Baud Rate Selection (25 MHz Bus Clock)

SPPR2	SPPR1	SPPR0	SPR2	SPR1	SPR0	Baud Rate Divisor	Baud Rate
0	0	0	0	0	0	2	12.5 MHz
0	0	0	0	0	1	4	6.25 MHz
0	0	0	0	1	0	8	3.125 MHz
0	0	0	0	1	1	16	1.5625 MHz
0	0	0	1	0	0	32	781.25 kHz
0	0	0	1	0	1	64	390.63 kHz
0	0	0	1	1	0	128	195.31 kHz
0	0	0	1	1	1	256	97.66 kHz
0	0	1	0	0	0	4	6.25 MHz
0	0	1	0	0	1	8	3.125 MHz
0	0	1	0	1	0	16	1.5625 MHz
0	0	1	0	1	1	32	781.25 kHz
0	0	1	1	0	0	64	390.63 kHz
0	0	1	1	0	1	128	195.31 kHz
0	0	1	1	1	0	256	97.66 kHz
0	0	1	1	1	1	512	48.83 kHz
0	1	0	0	0	0	6	4.16667 MHz
0	1	0	0	0	1	12	2.08333 MHz
0	1	0	0	1	0	24	1.04167 MHz
0	1	0	0	1	1	48	520.83 kHz
0	1	0	1	0	0	96	260.42 kHz
0	1	0	1	0	1	192	130.21 kHz
0	1	0	1	1	0	384	65.10 kHz
0	1	0	1	1	1	768	32.55 kHz
0	1	1	0	0	0	8	3.125 MHz
0	1	1	0	0	1	16	1.5625 MHz
0	1	1	0	1	0	32	781.25 kHz
0	1	1	0	1	1	64	390.63 kHz
0	1	1	1	0	0	128	195.31 kHz
0	1	1	1	0	1	256	97.66 kHz
0	1	1	1	1	0	512	48.83 kHz
0	1	1	1	1	1	1024	24.41 kHz
1	0	0	0	0	0	10	2.5 MHz
1	0	0	0	0	1	20	1.25 MHz
1	0	0	0	1	0	40	625 kHz
1	0	0	0	1	1	80	312.5 kHz
1	0	0	1	0	0	160	156.25 kHz
1	0	0	1	0	1	320	78.13 kHz
1	0	0	1	1	0	640	39.06 kHz

Table 9-7. Example SPI Baud Rate Selection (25 MHz Bus Clock) (continued)

SPPR2	SPPR1	SPPR0	SPR2	SPR1	SPR0	Baud Rate Divisor	Baud Rate
1	0	0	1	1	1	1280	19.53 kHz
1	0	1	0	0	0	12	2.08333 MHz
1	0	1	0	0	1	24	1.04167 MHz
1	0	1	0	1	0	48	520.83 kHz
1	0	1	0	1	1	96	260.42 kHz
1	0	1	1	0	0	192	130.21 kHz
1	0	1	1	0	1	384	65.10 kHz
1	0	1	1	1	0	768	32.55 kHz
1	0	1	1	1	1	1536	16.28 kHz
1	1	0	0	0	0	14	1.78571 MHz
1	1	0	0	0	1	28	892.86 kHz
1	1	0	0	1	0	56	446.43 kHz
1	1	0	0	1	1	112	223.21 kHz
1	1	0	1	0	0	224	111.61 kHz
1	1	0	1	0	1	448	55.80 kHz
1	1	0	1	1	0	896	27.90 kHz
1	1	0	1	1	1	1792	13.95 kHz
1	1	1	0	0	0	16	1.5625 MHz
1	1	1	0	0	1	32	781.25 kHz
1	1	1	0	1	0	64	390.63 kHz
1	1	1	0	1	1	128	195.31 kHz
1	1	1	1	0	0	256	97.66 kHz
1	1	1	1	0	1	512	48.83 kHz
1	1	1	1	1	0	1024	24.41 kHz
1	1	1	1	1	1	2048	12.21 kHz

NOTE

In slave mode of SPI S-clock speed DIV2 is not supported.

9.3.2.4 SPI Status Register (SPISR)

Module Base 0x0003

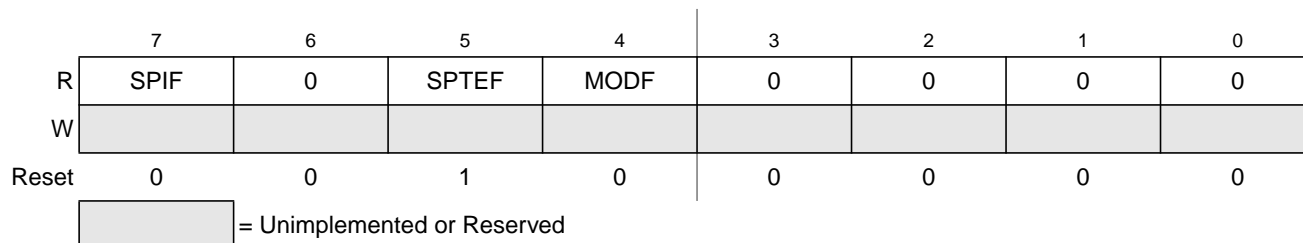

Figure 9-6. SPI Status Register (SPISR)

Read: anytime

Write: has no effect

Table 9-8. SPISR Field Descriptions

Field	Description
7 SPIF	SPIF Interrupt Flag — This bit is set after a received data byte has been transferred into the SPI Data Register. This bit is cleared by reading the SPISR register (with SPIF set) followed by a read access to the SPI Data Register. 0 Transfer not yet complete 1 New data copied to SPIDR
5 SPTEF	SPI Transmit Empty Interrupt Flag — If set, this bit indicates that the transmit data register is empty. To clear this bit and place data into the transmit data register, SPISR has to be read with SPTEF = 1, followed by a write to SPIDR. Any write to the SPI Data Register without reading SPTEF = 1, is effectively ignored. 0 SPI Data register not empty 1 SPI Data register empty
4 MODF	Mode Fault Flag — This bit is set if the SS input becomes low while the SPI is configured as a master and mode fault detection is enabled, MODFEN bit of SPICR2 register is set. Refer to MODFEN bit description in Section 9.3.2.2, “SPI Control Register 2 (SPICR2)” . The flag is cleared automatically by a read of the SPI Status Register (with MODF set) followed by a write to the SPI Control Register 1. 0 Mode fault has not occurred. 1 Mode fault has occurred.

9.3.2.5 SPI Data Register (SPIDR)

Module Base 0x0005

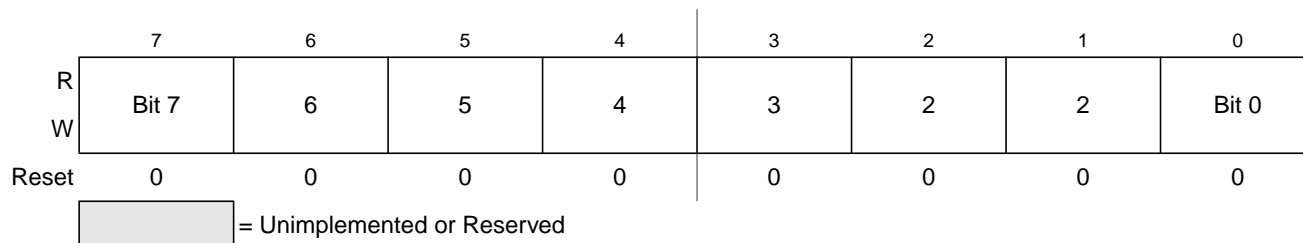

Figure 9-7. SPI Data Register (SPIDR)

Read: anytime; normally read only after SPIF is set

Write: anytime

The SPI Data Register is both the input and output register for SPI data. A write to this register allows a data byte to be queued and transmitted. For a SPI configured as a master, a queued data byte is transmitted immediately after the previous transmission has completed. The SPI Transmitter Empty Flag SPTEF in the SPISR register indicates when the SPI Data Register is ready to accept new data.

Reading the data can occur anytime from after the SPIF is set to before the end of the next transfer. If the SPIF is not serviced by the end of the successive transfers, those data bytes are lost and the data within the SPIDR retains the first byte until SPIF is serviced.

9.4 Functional Description

The SPI module allows a duplex, synchronous, serial communication between the MCU and peripheral devices. Software can poll the SPI status flags or SPI operation can be interrupt driven.

The SPI system is enabled by setting the SPI enable (SPE) bit in SPI Control Register 1. While SPE bit is set, the four associated SPI port pins are dedicated to the SPI function as:

- Slave select (\overline{SS})
- Serial clock (SCK)
- Master out/slave in (MOSI)
- Master in/slave out (MISO)

The main element of the SPI system is the SPI Data Register. The 8-bit data register in the master and the 8-bit data register in the slave are linked by the MOSI and MISO pins to form a distributed 16-bit register. When a data transfer operation is performed, this 16-bit register is serially shifted eight bit positions by the S-clock from the master, so data is exchanged between the master and the slave. Data written to the master SPI Data Register becomes the output data for the slave, and data read from the master SPI Data Register after a transfer operation is the input data from the slave.

A read of SPISR with SPTEF = 1 followed by a write to SPIDR puts data into the transmit data register. When a transfer is complete, received data is moved into the receive data register. Data may be read from this double-buffered system any time before the next transfer has completed. This 8-bit data register acts as the SPI receive data register for reads and as the SPI transmit data register for writes. A single SPI register address is used for reading data from the read data buffer and for writing data to the transmit data register.

The clock phase control bit (CPHA) and a clock polarity control bit (CPOL) in the SPI Control Register 1 (SPICR1) select one of four possible clock formats to be used by the SPI system. The CPOL bit simply selects a non-inverted or inverted clock. The CPHA bit is used to accommodate two fundamentally different protocols by sampling data on odd numbered SCK edges or on even numbered SCK edges (see [Section 9.4.3, “Transmission Formats”](#)).

The SPI can be configured to operate as a master or as a slave. When the MSTR bit in SPI Control Register1 is set, master mode is selected, when the MSTR bit is clear, slave mode is selected.

9.4.1 Master Mode

The SPI operates in master mode when the MSTR bit is set. Only a master SPI module can initiate transmissions. A transmission begins by writing to the master SPI Data Register. If the shift register is empty, the byte immediately transfers to the shift register. The byte begins shifting out on the MOSI pin under the control of the serial clock.

- S-clock

The SPR2, SPR1, and SPR0 baud rate selection bits in conjunction with the SPPR2, SPPR1, and SPPR0 baud rate preselection bits in the SPI Baud Rate register control the baud rate generator and determine the speed of the transmission. The SCK pin is the SPI clock output. Through the SCK pin, the baud rate generator of the master controls the shift register of the slave peripheral.
- MOSI and MISO Pins

In master mode, the function of the serial data output pin (MOSI) and the serial data input pin (MISO) is determined by the SPC0 and BIDIROE control bits.
- \overline{SS} Pin

If MODFEN and SSOE bit are set, the \overline{SS} pin is configured as slave select output. The \overline{SS} output becomes low during each transmission and is high when the SPI is in idle state.

If MODFEN is set and SSOE is cleared, the \overline{SS} pin is configured as input for detecting mode fault error. If the \overline{SS} input becomes low this indicates a mode fault error where another master tries to drive the MOSI and SCK lines. In this case, the SPI immediately switches to slave mode, by clearing the MSTR bit and also disables the slave output buffer MISO (or SISO in bidirectional mode). So the result is that all outputs are disabled and SCK, MOSI and MISO are inputs. If a transmission is in progress when the mode fault occurs, the transmission is aborted and the SPI is forced into idle state.

This mode fault error also sets the mode fault (MODF) flag in the SPI Status Register (SPISR). If the SPI interrupt enable bit (SPIE) is set when the MODF flag gets set, then an SPI interrupt sequence is also requested.

When a write to the SPI Data Register in the master occurs, there is a half SCK-cycle delay. After the delay, SCK is started within the master. The rest of the transfer operation differs slightly, depending on the clock format specified by the SPI clock phase bit, CPHA, in SPI Control Register 1 (see [Section 9.4.3, “Transmission Formats”](#)).

NOTE

A change of the bits CPOL, CPHA, SSOE, LSBFE, MODFEN, SPC0, BIDIROE with SPC0 set, SPPR2–SPPR0 and SPR2–SPR0 in master mode will abort a transmission in progress and force the SPI into idle state. The remote slave cannot detect this, therefore the master has to ensure that the remote slave is set back to idle state.

9.4.2 Slave Mode

The SPI operates in slave mode when the MSTR bit in SPI Control Register1 is clear.

- SCK Clock

In slave mode, SCK is the SPI clock input from the master.

- MISO and MOSI Pins

In slave mode, the function of the serial data output pin (MISO) and serial data input pin (MOSI) is determined by the SPC0 bit and BIDIROE bit in SPI Control Register 2.

- \overline{SS} Pin

The \overline{SS} pin is the slave select input. Before a data transmission occurs, the \overline{SS} pin of the slave SPI must be low. \overline{SS} must remain low until the transmission is complete. If \overline{SS} goes high, the SPI is forced into idle state.

The \overline{SS} input also controls the serial data output pin, if \overline{SS} is high (not selected), the serial data output pin is high impedance, and, if \overline{SS} is low the first bit in the SPI Data Register is driven out of the serial data output pin. Also, if the slave is not selected (\overline{SS} is high), then the SCK input is ignored and no internal shifting of the SPI shift register takes place.

Although the SPI is capable of duplex operation, some SPI peripherals are capable of only receiving SPI data in a slave mode. For these simpler devices, there is no serial data out pin.

NOTE

When peripherals with duplex capability are used, take care not to simultaneously enable two receivers whose serial outputs drive the same system slave's serial data output line.

As long as no more than one slave device drives the system slave's serial data output line, it is possible for several slaves to receive the same transmission from a master, although the master would not receive return information from all of the receiving slaves.

If the CPHA bit in SPI Control Register 1 is clear, odd numbered edges on the SCK input cause the data at the serial data input pin to be latched. Even numbered edges cause the value previously latched from the serial data input pin to shift into the LSB or MSB of the SPI shift register, depending on the LSBFE bit.

If the CPHA bit is set, even numbered edges on the SCK input cause the data at the serial data input pin to be latched. Odd numbered edges cause the value previously latched from the serial data input pin to shift into the LSB or MSB of the SPI shift register, depending on the LSBFE bit.

When CPHA is set, the first edge is used to get the first data bit onto the serial data output pin. When CPHA is clear and the \overline{SS} input is low (slave selected), the first bit of the SPI data is driven out of the serial data output pin. After the eighth shift, the transfer is considered complete and the received data is transferred into the SPI Data Register. To indicate transfer is complete, the SPIF flag in the SPI Status Register is set.

NOTE

A change of the bits CPOL, CPHA, SSOE, LSBFE, MODFEN, SPC0 and BIDIROE with SPC0 set in slave mode will corrupt a transmission in progress and has to be avoided.

9.4.3 Transmission Formats

During an SPI transmission, data is transmitted (shifted out serially) and received (shifted in serially) simultaneously. The serial clock (SCK) synchronizes shifting and sampling of the information on the two serial data lines. A slave select line allows selection of an individual slave SPI device, slave devices that are not selected do not interfere with SPI bus activities. Optionally, on a master SPI device, the slave select line can be used to indicate multiple-master bus contention.

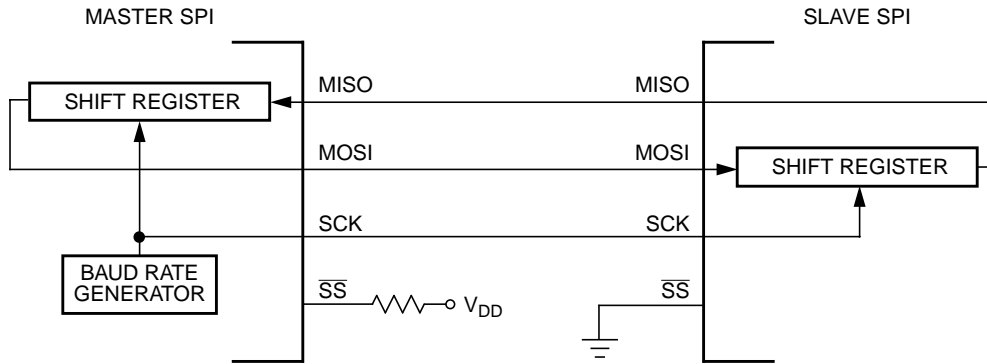

Figure 9-8. Master/Slave Transfer Block Diagram

9.4.3.1 Clock Phase and Polarity Controls

Using two bits in the SPI Control Register1, software selects one of four combinations of serial clock phase and polarity.

The CPOL clock polarity control bit specifies an active high or low clock and has no significant effect on the transmission format.

The CPHA clock phase control bit selects one of two fundamentally different transmission formats.

Clock phase and polarity should be identical for the master SPI device and the communicating slave device. In some cases, the phase and polarity are changed between transmissions to allow a master device to communicate with peripheral slaves having different requirements.

9.4.3.2 CPHA = 0 Transfer Format

The first edge on the SCK line is used to clock the first data bit of the slave into the master and the first data bit of the master into the slave. In some peripherals, the first bit of the slave's data is available at the slave's data out pin as soon as the slave is selected. In this format, the first SCK edge is issued a half cycle after \overline{SS} has become low.

A half SCK cycle later, the second edge appears on the SCK line. When this second edge occurs, the value previously latched from the serial data input pin is shifted into the LSB or MSB of the shift register, depending on LSBFE bit.

After this second edge, the next bit of the SPI master data is transmitted out of the serial data output pin of the master to the serial input pin on the slave. This process continues for a total of 16 edges on the SCK line, with data being latched on odd numbered edges and shifted on even numbered edges.

Data reception is double buffered. Data is shifted serially into the SPI shift register during the transfer and is transferred to the parallel SPI Data Register after the last bit is shifted in.

After the 16th (last) SCK edge:

- Data that was previously in the master SPI Data Register should now be in the slave data register and the data that was in the slave data register should be in the master.
- The SPIF flag in the SPI Status Register is set indicating that the transfer is complete.

Figure 9-9 is a timing diagram of an SPI transfer where CPHA = 0. SCK waveforms are shown for CPOL = 0 and CPOL = 1. The diagram may be interpreted as a master or slave timing diagram because the SCK, MISO, and MOSI pins are connected directly between the master and the slave. The MISO signal is the output from the slave and the MOSI signal is the output from the master. The \overline{SS} pin of the master must be either high or reconfigured as a general-purpose output not affecting the SPI.

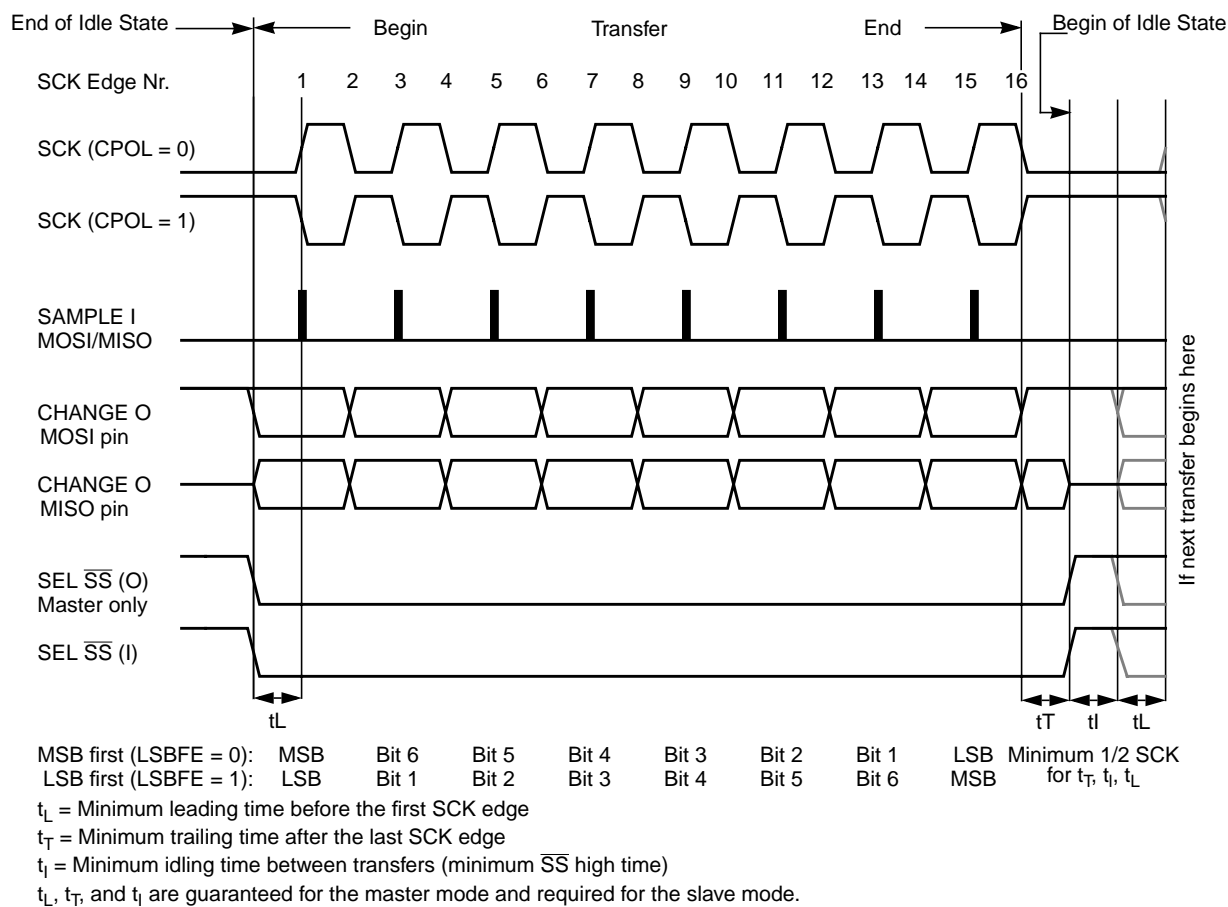

Figure 9-9. SPI Clock Format 0 (CPHA = 0)

In slave mode, if the \overline{SS} line is not deasserted between the successive transmissions then the content of the SPI Data Register is not transmitted, instead the last received byte is transmitted. If the \overline{SS} line is deasserted for at least minimum idle time (half SCK cycle) between successive transmissions then the content of the SPI Data Register is transmitted.

In master mode, with slave select output enabled the \overline{SS} line is always deasserted and reasserted between successive transfers for at least minimum idle time.

9.4.3.3 CPHA = 1 Transfer Format

Some peripherals require the first SCK edge before the first data bit becomes available at the data out pin, the second edge clocks data into the system. In this format, the first SCK edge is issued by setting the CPHA bit at the beginning of the 8-cycle transfer operation.

The first edge of SCK occurs immediately after the half SCK clock cycle synchronization delay. This first edge commands the slave to transfer its first data bit to the serial data input pin of the master.

A half SCK cycle later, the second edge appears on the SCK pin. This is the latching edge for both the master and slave.

When the third edge occurs, the value previously latched from the serial data input pin is shifted into the LSB or MSB of the SPI shift register, depending on LSBFE bit. After this edge, the next bit of the master data is coupled out of the serial data output pin of the master to the serial input pin on the slave.

This process continues for a total of 16 edges on the SCK line with data being latched on even numbered edges and shifting taking place on odd numbered edges.

Data reception is double buffered, data is serially shifted into the SPI shift register during the transfer and is transferred to the parallel SPI Data Register after the last bit is shifted in.

After the 16th SCK edge:

- Data that was previously in the SPI Data Register of the master is now in the data register of the slave, and data that was in the data register of the slave is in the master.
- The SPIF flag bit in SPISR is set indicating that the transfer is complete.

Figure 9-10 shows two clocking variations for CPHA = 1. The diagram may be interpreted as a master or slave timing diagram because the SCK, MISO, and MOSI pins are connected directly between the master and the slave. The MISO signal is the output from the slave, and the MOSI signal is the output from the master. The \overline{SS} line is the slave select input to the slave. The \overline{SS} pin of the master must be either high or reconfigured as a general-purpose output not affecting the SPI.

The \overline{SS} line can remain active low between successive transfers (can be tied low at all times). This format is sometimes preferred in systems having a single fixed master and a single slave that drive the MISO data line.

- Back-to-back transfers in master mode

In master mode, if a transmission has completed and a new data byte is available in the SPI Data Register, this byte is send out immediately without a trailing and minimum idle time.

The SPI interrupt request flag (SPIF) is common to both the master and slave modes. SPIF gets set one half SCK cycle after the last SCK edge.

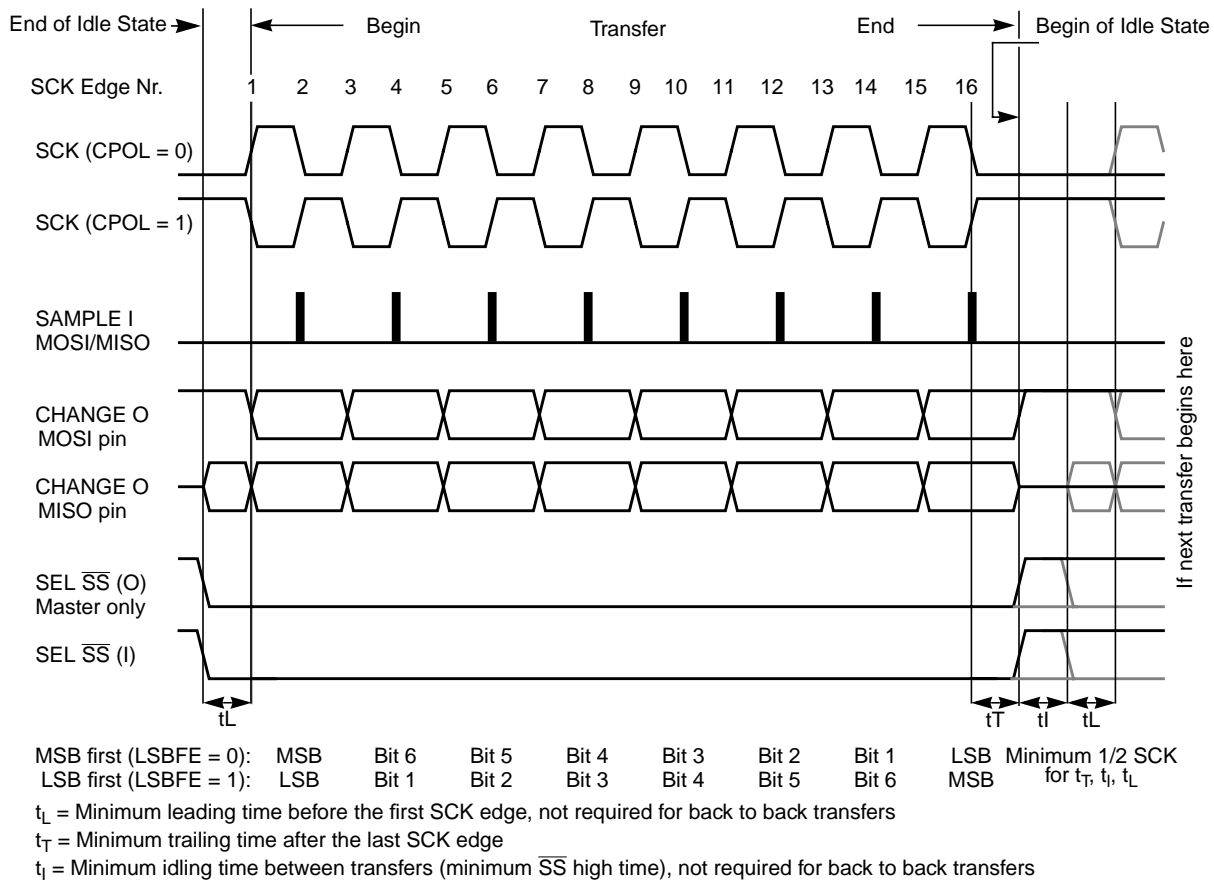

Figure 9-10. SPI Clock Format 1 (CPHA = 1)

9.4.4 SPI Baud Rate Generation

Baud rate generation consists of a series of divider stages. Six bits in the SPI Baud Rate register (SPPR2, SPPR1, SPPR0, SPR2, SPR1, and SPR0) determine the divisor to the SPI module clock which results in the SPI baud rate.

The SPI clock rate is determined by the product of the value in the baud rate preselection bits (SPPR2–SPPR0) and the value in the baud rate selection bits (SPR2–SPR0). The module clock divisor equation is shown in [Figure 9-11](#)

When all bits are clear (the default condition), the SPI module clock is divided by 2. When the selection bits (SPR2–SPR0) are 001 and the preselection bits (SPPR2–SPPR0) are 000, the module clock divisor becomes 4. When the selection bits are 010, the module clock divisor becomes 8 etc.

When the preselection bits are 001, the divisor determined by the selection bits is multiplied by 2. When the preselection bits are 010, the divisor is multiplied by 3, etc. See [Table 9-7](#) for baud rate calculations for all bit conditions, based on a 25-MHz bus clock. The two sets of selects allows the clock to be divided by a non-power of two to achieve other baud rates such as divide by 6, divide by 10, etc.

The baud rate generator is activated only when the SPI is in the master mode and a serial transfer is taking place. In the other cases, the divider is disabled to decrease I_{DD} current.

$$\text{BaudRateDivisor} = (\text{SPPR} + 1) \cdot 2^{(\text{SPR} + 1)}$$

Figure 9-11. Baud Rate Divisor Equation

9.4.5 Special Features

9.4.5.1 \overline{SS} Output

The \overline{SS} output feature automatically drives the \overline{SS} pin low during transmission to select external devices and drives it high during idle to deselect external devices. When \overline{SS} output is selected, the \overline{SS} output pin is connected to the \overline{SS} input pin of the external device.

The \overline{SS} output is available only in master mode during normal SPI operation by asserting SSOE and MODFEN bit as shown in [Table 9-3](#).

The mode fault feature is disabled while \overline{SS} output is enabled.

NOTE

Care must be taken when using the \overline{SS} output feature in a multimaster system because the mode fault feature is not available for detecting system errors between masters.

9.4.5.2 Bidirectional Mode (MOSI or MISO)

The bidirectional mode is selected when the SPC0 bit is set in SPI Control Register 2 (see [Table 9-9](#)). In this mode, the SPI uses only one serial data pin for the interface with external device(s). The MSTR bit decides which pin to use. The MOSI pin becomes the serial data I/O (MOMI) pin for the master mode, and the MISO pin becomes serial data I/O (SISO) pin for the slave mode. The MISO pin in master mode and MOSI pin in slave mode are not used by the SPI.

Table 9-9. Normal Mode and Bidirectional Mode

When SPE = 1	Master Mode MSTR = 1	Slave Mode MSTR = 0
Normal Mode SPC0 = 0		
Bidirectional Mode SPC0 = 1		

The direction of each serial I/O pin depends on the BIDIROE bit. If the pin is configured as an output, serial data from the shift register is driven out on the pin. The same pin is also the serial input to the shift register.

The SCK is output for the master mode and input for the slave mode.

The \overline{SS} is the input or output for the master mode, and it is always the input for the slave mode.

The bidirectional mode does not affect SCK and \overline{SS} functions.

NOTE

In bidirectional master mode, with mode fault enabled, both data pins MISO and MOSI can be occupied by the SPI, though MOSI is normally used for transmissions in bidirectional mode and MISO is not used by the SPI. If a mode fault occurs, the SPI is automatically switched to slave mode, in this case MISO becomes occupied by the SPI and MOSI is not used. This has to be considered, if the MISO pin is used for other purpose.

9.4.6 Error Conditions

The SPI has one error condition:

- Mode fault error

9.4.6.1 Mode Fault Error

If the \overline{SS} input becomes low while the SPI is configured as a master, it indicates a system error where more than one master may be trying to drive the MOSI and SCK lines simultaneously. This condition is not permitted in normal operation, the MODF bit in the SPI Status Register is set automatically provided the MODFEN bit is set.

In the special case where the SPI is in master mode and MODFEN bit is cleared, the \overline{SS} pin is not used by the SPI. In this special case, the mode fault error function is inhibited and MODF remains cleared. In case the SPI system is configured as a slave, the \overline{SS} pin is a dedicated input pin. Mode fault error doesn't occur in slave mode.

If a mode fault error occurs the SPI is switched to slave mode, with the exception that the slave output buffer is disabled. So SCK, MISO and MOSI pins are forced to be high impedance inputs to avoid any possibility of conflict with another output driver. A transmission in progress is aborted and the SPI is forced into idle state.

If the mode fault error occurs in the bidirectional mode for a SPI system configured in master mode, output enable of the MOMI (MOSI in bidirectional mode) is cleared if it was set. No mode fault error occurs in the bidirectional mode for SPI system configured in slave mode.

The mode fault flag is cleared automatically by a read of the SPI Status Register (with MODF set) followed by a write to SPI Control Register 1. If the mode fault flag is cleared, the SPI becomes a normal master or slave again.

9.4.7 Operation in Run Mode

In run mode with the SPI system enable (SPE) bit in the SPI control register clear, the SPI system is in a low-power, disabled state. SPI registers remain accessible, but clocks to the core of this module are disabled.

9.4.8 Operation in Wait Mode

SPI operation in wait mode depends upon the state of the SPISWAI bit in SPI Control Register 2.

- If SPISWAI is clear, the SPI operates normally when the CPU is in wait mode
- If SPISWAI is set, SPI clock generation ceases and the SPI module enters a power conservation state when the CPU is in wait mode.
 - If SPISWAI is set and the SPI is configured for master, any transmission and reception in progress stops at wait mode entry. The transmission and reception resumes when the SPI exits wait mode.
 - If SPISWAI is set and the SPI is configured as a slave, any transmission and reception in progress continues if the SCK continues to be driven from the master. This keeps the slave synchronized to the master and the SCK.

If the master transmits several bytes while the slave is in wait mode, the slave will continue to send out bytes consistent with the operation mode at the start of wait mode (i.e. If the slave is currently sending its SPIDR to the master, it will continue to send the same byte. Else if the slave is currently sending the last received byte from the master, it will continue to send each previous master byte).

NOTE

Care must be taken when expecting data from a master while the slave is in wait or stop mode. Even though the shift register will continue to operate, the rest of the SPI is shut down (i.e. a SPIF interrupt will **not** be generated until exiting stop or wait mode). Also, the byte from the shift register will not be copied into the SPIDR register until after the slave SPI has exited wait or stop mode. A SPIF flag and SPIDR copy is only generated if wait mode is entered or exited during a transmission. If the slave enters wait mode in idle mode and exits wait mode in idle mode, neither a SPIF nor a SPIDR copy will occur.

9.4.9 Operation in Stop Mode

Stop mode is dependent on the system. The SPI enters stop mode when the module clock is disabled (held high or low). If the SPI is in master mode and exchanging data when the CPU enters stop mode, the transmission is frozen until the CPU exits stop mode. After stop, data to and from the external SPI is exchanged correctly. In slave mode, the SPI will stay synchronized with the master.

The stop mode is not dependent on the SPISWAI bit.

9.5 Reset

The reset values of registers and signals are described in the Memory Map and Registers section (see [Section 9.3, “Memory Map and Register Definition”](#)) which details the registers and their bit-fields.

- If a data transmission occurs in slave mode after reset without a write to SPIDR, it will transmit garbage, or the byte last received from the master before the reset.
- Reading from the SPIDR after reset will always read a byte of zeros.

9.6 Interrupts

The SPIV3 only originates interrupt requests when SPI is enabled (SPE bit in SPICR1 set). The following is a description of how the SPIV3 makes a request and how the MCU should acknowledge that request. The interrupt vector offset and interrupt priority are chip dependent.

The interrupt flags MODF, SPIF and SPTEF are logically ORed to generate an interrupt request.

9.6.1 MODF

MODF occurs when the master detects an error on the \overline{SS} pin. The master SPI must be configured for the MODF feature (see [Table 9-3](#)). After MODF is set, the current transfer is aborted and the following bit is changed:

- MSTR = 0, The master bit in SPICR1 resets.

The MODF interrupt is reflected in the status register MODF flag. Clearing the flag will also clear the interrupt. This interrupt will stay active while the MODF flag is set. MODF has an automatic clearing process which is described in [Section 9.3.2.4, “SPI Status Register \(SPISR\)”](#).

9.6.2 SPIF

SPIF occurs when new data has been received and copied to the SPI Data Register. After SPIF is set, it does not clear until it is serviced. SPIF has an automatic clearing process which is described in [Section 9.3.2.4, “SPI Status Register \(SPISR\)”](#). In the event that the SPIF is not serviced before the end of the next transfer (i.e. SPIF remains active throughout another transfer), the latter transfers will be ignored and no new data will be copied into the SPIDR.

9.6.3 SPTEF

SPTEF occurs when the SPI Data Register is ready to accept new data. After SPTEF is set, it does not clear until it is serviced. SPTEF has an automatic clearing process which is described in [Section 9.3.2.4, “SPI Status Register \(SPISR\)”](#).

Chapter 10

Inter-Integrated Circuit (IICV2) Block Description

10.1 Introduction

The inter-IC bus (IIC) is a two-wire, bidirectional serial bus that provides a simple, efficient method of data exchange between devices. Being a two-wire device, the IIC bus minimizes the need for large numbers of connections between devices, and eliminates the need for an address decoder.

This bus is suitable for applications requiring occasional communications over a short distance between a number of devices. It also provides flexibility, allowing additional devices to be connected to the bus for further expansion and system development.

The interface is designed to operate up to 100 kbps with maximum bus loading and timing. The device is capable of operating at higher baud rates, up to a maximum of $\text{clock}/20$, with reduced bus loading. The maximum communication length and the number of devices that can be connected are limited by a maximum bus capacitance of 400 pF.

10.1.1 Features

The IIC module has the following key features:

- Compatible with I2C bus standard
- Multi-master operation
- Software programmable for one of 256 different serial clock frequencies
- Software selectable acknowledge bit
- Interrupt driven byte-by-byte data transfer
- Arbitration lost interrupt with automatic mode switching from master to slave
- Calling address identification interrupt
- Start and stop signal generation/detection
- Repeated start signal generation
- Acknowledge bit generation/detection
- Bus busy detection

10.1.2 Modes of Operation

The IIC functions the same in normal, special, and emulation modes. It has two low power modes: wait and stop modes.

10.1.3 Block Diagram

The block diagram of the IIC module is shown in [Figure 10-1](#).

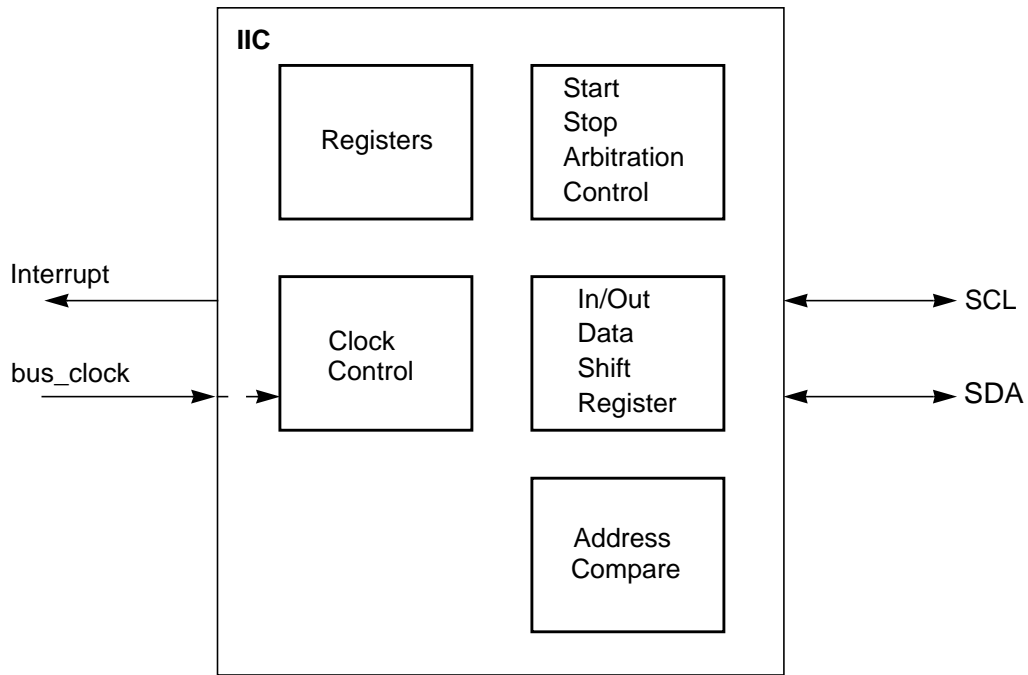

Figure 10-1. IIC Block Diagram

10.2 External Signal Description

The IICV2 module has two external pins.

10.2.1 IIC_SCL — Serial Clock Line Pin

This is the bidirectional serial clock line (SCL) of the module, compatible to the IIC bus specification.

10.2.2 IIC_SDA — Serial Data Line Pin

This is the bidirectional serial data line (SDA) of the module, compatible to the IIC bus specification.

10.3 Memory Map and Register Definition

This section provides a detailed description of all memory and registers for the IIC module.

10.3.1 Module Memory Map

The memory map for the IIC module is given below in [Table 10-2](#). The address listed for each register is the address offset. The total address for each register is the sum of the base address for the IIC module and the address offset for each register.

10.3.2 Register Descriptions

This section consists of register descriptions in address order. Each description includes a standard register diagram with an associated figure number. Details of register bit and field function follow the register diagrams, in bit order.

Register Name		Bit 7	6	5	4	3	2	1	Bit 0
0x0000 IBAD	R W	ADR7	ADR6	ADR5	ADR4	ADR3	ADR2	ADR1	0
0x0001 IBFD	R W	IBC7	IBC6	IBC5	IBC4	IBC3	IBC2	IBC1	IBC0
0x0002 IBCR	R W	IBEN	IBIE	MS/ \overline{SL}	Tx/ \overline{Rx}	TXAK	0 RSTA	0	IBSWAI
0x0003 IBSR	R W	TCF	IAAS	IBB	IBAL	0	SRW	IBIF	RXAK
0x0004 IBDR	R W	D7	D6	D5	D4	D3	D2	D1	D0

= Unimplemented or Reserved

Figure 10-2. IIC Register Summary

10.3.2.1 IIC Address Register (IBAD)

Offset Module Base +0x0000

	7	6	5	4	3	2	1	0
R W	ADR7	ADR6	ADR5	ADR4	ADR3	ADR2	ADR1	0
Reset	0	0	0	0	0	0	0	0

= Unimplemented or Reserved

Figure 10-3. IIC Bus Address Register (IBAD)

Read and write anytime

This register contains the address the IIC bus will respond to when addressed as a slave; note that it is not the address sent on the bus during the address transfer.

Table 10-1. IBAD Field Descriptions

Field	Description
7:1 ADR[7:1]	Slave Address — Bit 1 to bit 7 contain the specific slave address to be used by the IIC bus module. The default mode of IIC bus is slave mode for an address match on the bus.
0 Reserved	Reserved — Bit 0 of the IBAD is reserved for future compatibility. This bit will always read 0.

10.3.2.2 IIC Frequency Divider Register (IBFD)

Offset Module Base + 0x0001

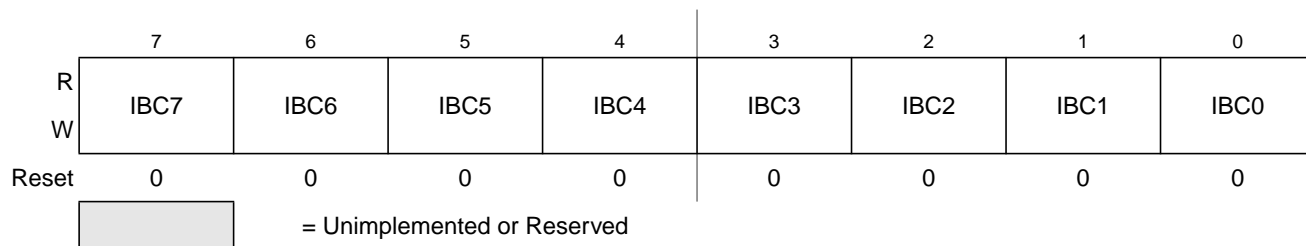

Figure 10-4. IIC Bus Frequency Divider Register (IBFD)

Read and write anytime

Table 10-2. IBFD Field Descriptions

Field	Description
7:0 IBC[7:0]	I Bus Clock Rate 7:0 — This field is used to prescale the clock for bit rate selection. The bit clock generator is implemented as a prescale divider — IBC7:6, prescaled shift register — IBC5:3 select the prescaler divider and IBC2-0 select the shift register tap point. The IBC bits are decoded to give the tap and prescale values as shown in Table 10-3 .

Table 10-3. I-Bus Tap and Prescale Values

IBC2-0 (bin)	SCL Tap (clocks)	SDA Tap (clocks)
000	5	1
001	6	1
010	7	2
011	8	2
100	9	3
101	10	3
110	12	4
111	15	4

IBC5-3 (bin)	scl2start (clocks)	scl2stop (clocks)	scl2tap (clocks)	tap2tap (clocks)
000	2	7	4	1
001	2	7	4	2

IBC5-3 (bin)	scl2start (clocks)	scl2stop (clocks)	scl2tap (clocks)	tap2tap (clocks)
010	2	9	6	4
011	6	9	6	8
100	14	17	14	16
101	30	33	30	32
110	62	65	62	64
111	126	129	126	128

Table 10-4. Multiplier Factor

IBC7-6	MUL
00	01
01	02
10	04
11	RESERVED

The number of clocks from the falling edge of SCL to the first tap (Tap[1]) is defined by the values shown in the scl2tap column of [Table 10-3](#), all subsequent tap points are separated by 2^{IBC5-3} as shown in the tap2tap column in [Table 10-3](#). The SCL Tap is used to generate the SCL period and the SDA Tap is used to determine the delay from the falling edge of SCL to SDA changing, the SDA hold time.

IBC7-6 defines the multiplier factor MUL. The values of MUL are shown in the [Table 10-4](#).

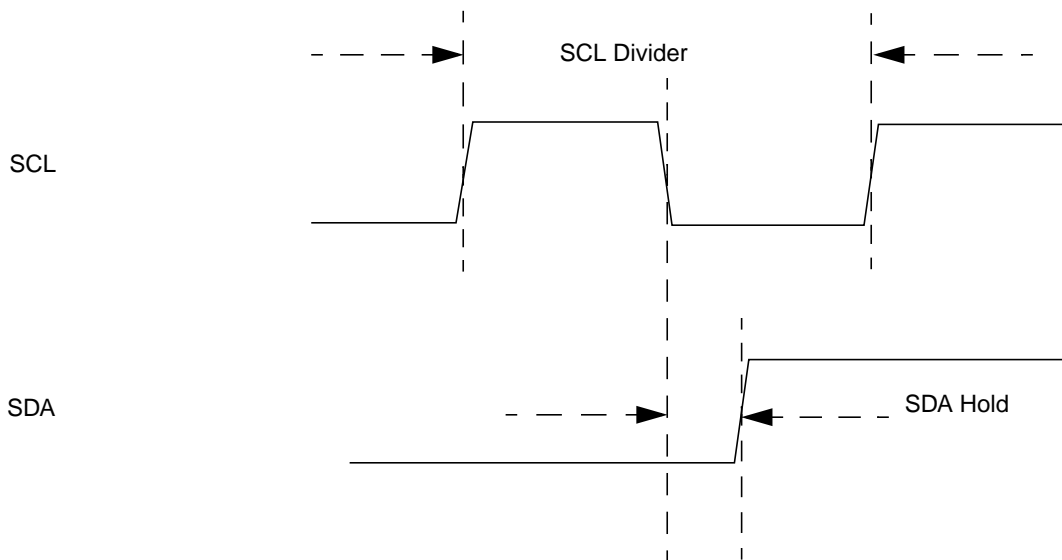

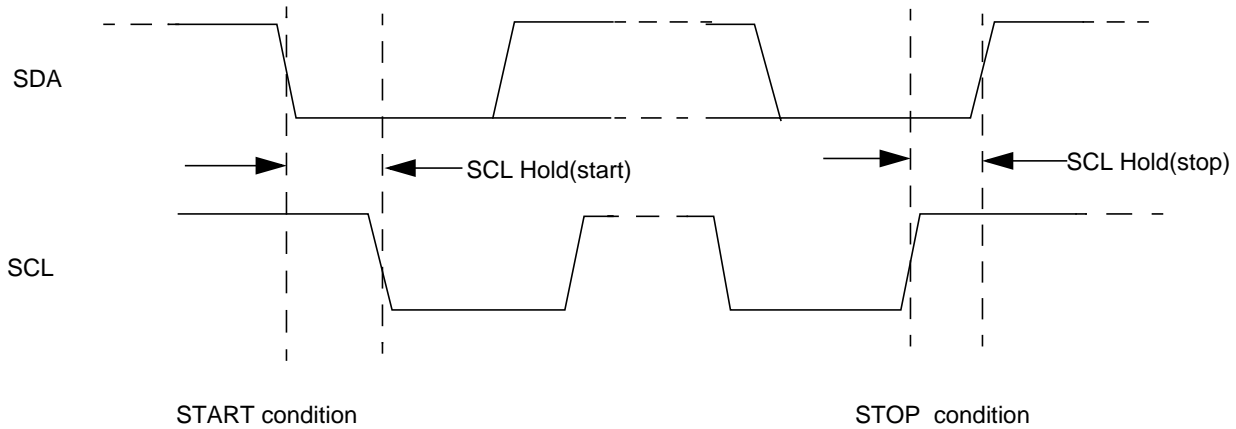
Figure 10-5. SCL Divider and SDA Hold

The equation used to generate the divider values from the IBFD bits is:

$$\text{SCL Divider} = \text{MUL} \times \{2 \times (\text{scl2tap} + [(\text{SCL_Tap} - 1) \times \text{tap2tap}] + 2)\}$$

The SDA hold delay is equal to the CPU clock period multiplied by the SDA Hold value shown in [Table 10-5](#). The equation used to generate the SDA Hold value from the IBFD bits is:

$$\text{SDA Hold} = \text{MUL} \times \{\text{scl2tap} + [(\text{SDA_Tap} - 1) \times \text{tap2tap}] + 3\}$$

The equation for SCL Hold values to generate the start and stop conditions from the IBFD bits is:

$$\text{SCL Hold(start)} = \text{MUL} \times [\text{scl2start} + (\text{SCL_Tap} - 1) \times \text{tap2tap}]$$

$$\text{SCL Hold(stop)} = \text{MUL} \times [\text{scl2stop} + (\text{SCL_Tap} - 1) \times \text{tap2tap}]$$

Table 10-5. IIC Divider and Hold Values (Sheet 1 of 5)

IBC[7:0] (hex)	SCL Divider (clocks)	SDA Hold (clocks)	SCL Hold (start)	SCL Hold (stop)
MUL=1				
00	20	7	6	11
01	22	7	7	12
02	24	8	8	13
03	26	8	9	14
04	28	9	10	15
05	30	9	11	16
06	34	10	13	18
07	40	10	16	21
08	28	7	10	15
09	32	7	12	17
0A	36	9	14	19
0B	40	9	16	21
0C	44	11	18	23
0D	48	11	20	25
0E	56	13	24	29
0F	68	13	30	35
10	48	9	18	25

Table 10-5. IIC Divider and Hold Values (Sheet 2 of 5)

IBC[7:0] (hex)	SCL Divider (clocks)	SDA Hold (clocks)	SCL Hold (start)	SCL Hold (stop)
11	56	9	22	29
12	64	13	26	33
13	72	13	30	37
14	80	17	34	41
15	88	17	38	45
16	104	21	46	53
17	128	21	58	65
18	80	9	38	41
19	96	9	46	49
1A	112	17	54	57
1B	128	17	62	65
1C	144	25	70	73
1D	160	25	78	81
1E	192	33	94	97
1F	240	33	118	121
20	160	17	78	81
21	192	17	94	97
22	224	33	110	113
23	256	33	126	129
24	288	49	142	145
25	320	49	158	161
26	384	65	190	193
27	480	65	238	241
28	320	33	158	161
29	384	33	190	193
2A	448	65	222	225
2B	512	65	254	257
2C	576	97	286	289
2D	640	97	318	321
2E	768	129	382	385
2F	960	129	478	481
30	640	65	318	321
31	768	65	382	385
32	896	129	446	449
33	1024	129	510	513
34	1152	193	574	577
35	1280	193	638	641
36	1536	257	766	769
37	1920	257	958	961
38	1280	129	638	641
39	1536	129	766	769
3A	1792	257	894	897
3B	2048	257	1022	1025
3C	2304	385	1150	1153
3D	2560	385	1278	1281

Table 10-5. IIC Divider and Hold Values (Sheet 3 of 5)

IBC[7:0] (hex)	SCL Divider (clocks)	SDA Hold (clocks)	SCL Hold (start)	SCL Hold (stop)
3E	3072	513	1534	1537
3F	3840	513	1918	1921
MUL=2				
40	40	14	12	22
41	44	14	14	24
42	48	16	16	26
43	52	16	18	28
44	56	18	20	30
45	60	18	22	32
46	68	20	26	36
47	80	20	32	42
48	56	14	20	30
49	64	14	24	34
4A	72	18	28	38
4B	80	18	32	42
4C	88	22	36	46
4D	96	22	40	50
4E	112	26	48	58
4F	136	26	60	70
50	96	18	36	50
51	112	18	44	58
52	128	26	52	66
53	144	26	60	74
54	160	34	68	82
55	176	34	76	90
56	208	42	92	106
57	256	42	116	130
58	160	18	76	82
59	192	18	92	98
5A	224	34	108	114
5B	256	34	124	130
5C	288	50	140	146
5D	320	50	156	162
5E	384	66	188	194
5F	480	66	236	242
60	320	34	156	162
61	384	34	188	194
62	448	66	220	226
63	512	66	252	258
64	576	98	284	290
65	640	98	316	322
66	768	130	380	386
67	960	130	476	482
68	640	66	316	322
69	768	66	380	386

Table 10-5. IIC Divider and Hold Values (Sheet 4 of 5)

IBC[7:0] (hex)	SCL Divider (clocks)	SDA Hold (clocks)	SCL Hold (start)	SCL Hold (stop)
6A	896	130	444	450
6B	1024	130	508	514
6C	1152	194	572	578
6D	1280	194	636	642
6E	1536	258	764	770
6F	1920	258	956	962
70	1280	130	636	642
71	1536	130	764	770
72	1792	258	892	898
73	2048	258	1020	1026
74	2304	386	1148	1154
75	2560	386	1276	1282
76	3072	514	1532	1538
77	3840	514	1916	1922
78	2560	258	1276	1282
79	3072	258	1532	1538
7A	3584	514	1788	1794
7B	4096	514	2044	2050
7C	4608	770	2300	2306
7D	5120	770	2556	2562
7E	6144	1026	3068	3074
7F	7680	1026	3836	3842
MUL=4				
80	80	28	24	44
81	88	28	28	48
82	96	32	32	52
83	104	32	36	56
84	112	36	40	60
85	120	36	44	64
86	136	40	52	72
87	160	40	64	84
88	112	28	40	60
89	128	28	48	68
8A	144	36	56	76
8B	160	36	64	84
8C	176	44	72	92
8D	192	44	80	100
8E	224	52	96	116
8F	272	52	120	140
90	192	36	72	100
91	224	36	88	116
92	256	52	104	132
93	288	52	120	148
94	320	68	136	164
95	352	68	152	180

Table 10-5. IIC Divider and Hold Values (Sheet 5 of 5)

IBC[7:0] (hex)	SCL Divider (clocks)	SDA Hold (clocks)	SCL Hold (start)	SCL Hold (stop)
96	416	84	184	212
97	512	84	232	260
98	320	36	152	164
99	384	36	184	196
9A	448	68	216	228
9B	512	68	248	260
9C	576	100	280	292
9D	640	100	312	324
9E	768	132	376	388
9F	960	132	472	484
A0	640	68	312	324
A1	768	68	376	388
A2	896	132	440	452
A3	1024	132	504	516
A4	1152	196	568	580
A5	1280	196	632	644
A6	1536	260	760	772
A7	1920	260	952	964
A8	1280	132	632	644
A9	1536	132	760	772
AA	1792	260	888	900
AB	2048	260	1016	1028
AC	2304	388	1144	1156
AD	2560	388	1272	1284
AE	3072	516	1528	1540
AF	3840	516	1912	1924
B0	2560	260	1272	1284
B1	3072	260	1528	1540
B2	3584	516	1784	1796
B3	4096	516	2040	2052
B4	4608	772	2296	2308
B5	5120	772	2552	2564
B6	6144	1028	3064	3076
B7	7680	1028	3832	3844
B8	5120	516	2552	2564
B9	6144	516	3064	3076
BA	7168	1028	3576	3588
BB	8192	1028	4088	4100
BC	9216	1540	4600	4612
BD	10240	1540	5112	5124
BE	12288	2052	6136	6148
BF	15360	2052	7672	7684

10.3.2.3 IIC Control Register (IBCR)

Offset Module Base + 0x0002

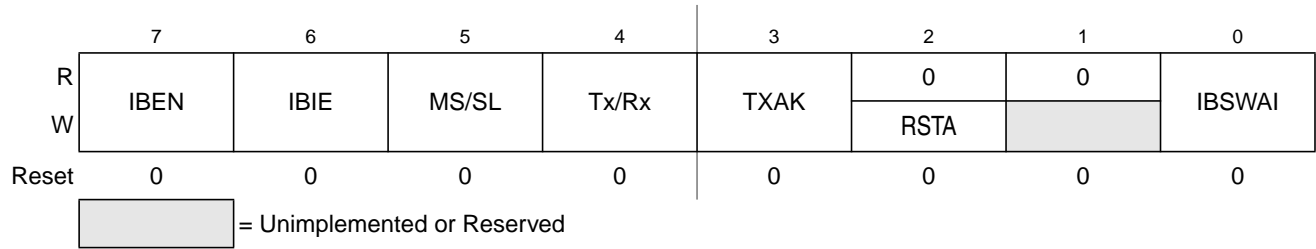

Figure 10-6. IIC Bus Control Register (IBCR)

Read and write anytime

Table 10-6. IBCR Field Descriptions

Field	Description
7 IBEN	<p>I-Bus Enable — This bit controls the software reset of the entire IIC bus module.</p> <p>0 The module is reset and disabled. This is the power-on reset situation. When low the interface is held in reset but registers can be accessed</p> <p>1 The IIC bus module is enabled. This bit must be set before any other IBCR bits have any effect</p> <p>If the IIC bus module is enabled in the middle of a byte transfer the interface behaves as follows: slave mode ignores the current transfer on the bus and starts operating whenever a subsequent start condition is detected. Master mode will not be aware that the bus is busy, hence if a start cycle is initiated then the current bus cycle may become corrupt. This would ultimately result in either the current bus master or the IIC bus module losing arbitration, after which bus operation would return to normal.</p>
6 IBIE	<p>I-Bus Interrupt Enable</p> <p>0 Interrupts from the IIC bus module are disabled. Note that this does not clear any currently pending interrupt condition</p> <p>1 Interrupts from the IIC bus module are enabled. An IIC bus interrupt occurs provided the IBIF bit in the status register is also set.</p>
5 MS/SL	<p>Master/Slave Mode Select Bit — Upon reset, this bit is cleared. When this bit is changed from 0 to 1, a START signal is generated on the bus, and the master mode is selected. When this bit is changed from 1 to 0, a STOP signal is generated and the operation mode changes from master to slave. A STOP signal should only be generated if the IBIF flag is set. MS/SL is cleared without generating a STOP signal when the master loses arbitration.</p> <p>0 Slave Mode</p> <p>1 Master Mode</p>
4 Tx/Rx	<p>Transmit/Receive Mode Select Bit — This bit selects the direction of master and slave transfers. When addressed as a slave this bit should be set by software according to the SRW bit in the status register. In master mode this bit should be set according to the type of transfer required. Therefore, for address cycles, this bit will always be high.</p> <p>0 Receive</p> <p>1 Transmit</p>
3 TXAK	<p>Transmit Acknowledge Enable — This bit specifies the value driven onto SDA during data acknowledge cycles for both master and slave receivers. The IIC module will always acknowledge address matches, provided it is enabled, regardless of the value of TXAK. Note that values written to this bit are only used when the IIC bus is a receiver, not a transmitter.</p> <p>0 An acknowledge signal will be sent out to the bus at the 9th clock bit after receiving one byte data</p> <p>1 No acknowledge signal response is sent (i.e., acknowledge bit = 1)</p>

Table 10-6. IBCR Field Descriptions (continued)

Field	Description
2 RSTA	Repeat Start — Writing a 1 to this bit will generate a repeated START condition on the bus, provided it is the current bus master. This bit will always be read as a low. Attempting a repeated start at the wrong time, if the bus is owned by another master, will result in loss of arbitration. 1 Generate repeat start cycle
1 RESERVED	Reserved — Bit 1 of the IBCR is reserved for future compatibility. This bit will always read 0.
0 IBSWAI	I Bus Interface Stop in Wait Mode 0 IIC bus module clock operates normally 1 Halt IIC bus module clock generation in wait mode

Wait mode is entered via execution of a CPU WAI instruction. In the event that the IBSWAI bit is set, all clocks internal to the IIC will be stopped and any transmission currently in progress will halt. If the CPU were woken up by a source other than the IIC module, then clocks would restart and the IIC would resume from where was during the previous transmission. It is not possible for the IIC to wake up the CPU when its internal clocks are stopped.

If it were the case that the IBSWAI bit was cleared when the WAI instruction was executed, the IIC internal clocks and interface would remain alive, continuing the operation which was currently underway. It is also possible to configure the IIC such that it will wake up the CPU via an interrupt at the conclusion of the current operation. See the discussion on the IBIF and IBIE bits in the IBSR and IBCR, respectively.

10.3.2.4 IIC Status Register (IBSR)

Offset Module Base + 0x0003

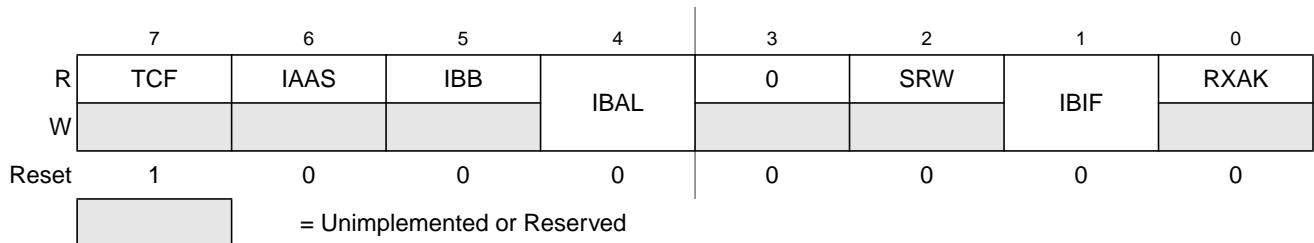

Figure 10-7. IIC Bus Status Register (IBSR)

This status register is read-only with exception of bit 1 (IBIF) and bit 4 (IBAL), which are software clearable.

Table 10-7. IBSR Field Descriptions

Field	Description
7 TCF	Data Transferring Bit — While one byte of data is being transferred, this bit is cleared. It is set by the falling edge of the 9th clock of a byte transfer. Note that this bit is only valid during or immediately following a transfer to the IIC module or from the IIC module. 0 Transfer in progress 1 Transfer complete

Table 10-7. IBSR Field Descriptions (continued)

Field	Description
6 IAAS	Addressed as a Slave Bit — When its own specific address (I-bus address register) is matched with the calling address, this bit is set. The CPU is interrupted provided the IBIE is set. Then the CPU needs to check the SRW bit and set its Tx/Rx mode accordingly. Writing to the I-bus control register clears this bit. 0 Not addressed 1 Addressed as a slave
5 IBB	Bus Busy Bit 0 This bit indicates the status of the bus. When a START signal is detected, the IBB is set. If a STOP signal is detected, IBB is cleared and the bus enters idle state. 1 Bus is busy
4 IBAL	Arbitration Lost — The arbitration lost bit (IBAL) is set by hardware when the arbitration procedure is lost. Arbitration is lost in the following circumstances: 1. SDA sampled low when the master drives a high during an address or data transmit cycle. 2. SDA sampled low when the master drives a high during the acknowledge bit of a data receive cycle. 3. A start cycle is attempted when the bus is busy. 4. A repeated start cycle is requested in slave mode. 5. A stop condition is detected when the master did not request it. This bit must be cleared by software, by writing a one to it. A write of 0 has no effect on this bit.
3 RESERVED	Reserved — Bit 3 of IBSR is reserved for future use. A read operation on this bit will return 0.
2 SRW	Slave Read/Write — When IAAS is set this bit indicates the value of the R/W command bit of the calling address sent from the master This bit is only valid when the I-bus is in slave mode, a complete address transfer has occurred with an address match and no other transfers have been initiated. Checking this bit, the CPU can select slave transmit/receive mode according to the command of the master. 0 Slave receive, master writing to slave 1 Slave transmit, master reading from slave
1 IBIF	I-Bus Interrupt — The IBIF bit is set when one of the following conditions occurs: — Arbitration lost (IBAL bit set) — Byte transfer complete (TCF bit set) — Addressed as slave (IAAS bit set) It will cause a processor interrupt request if the IBIE bit is set. This bit must be cleared by software, writing a one to it. A write of 0 has no effect on this bit.
0 RXAK	Received Acknowledge — The value of SDA during the acknowledge bit of a bus cycle. If the received acknowledge bit (RXAK) is low, it indicates an acknowledge signal has been received after the completion of 8 bits data transmission on the bus. If RXAK is high, it means no acknowledge signal is detected at the 9th clock. 0 Acknowledge received 1 No acknowledge received

10.3.2.5 IIC Data I/O Register (IBDR)

Offset Module Base + 0x0004

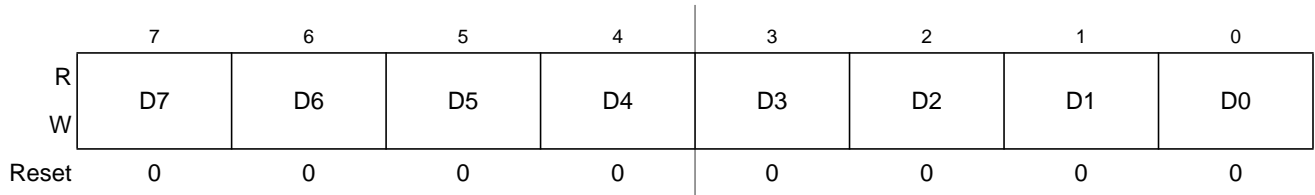

Figure 10-8. IIC Bus Data I/O Register (IBDR)

In master transmit mode, when data is written to the IBDR a data transfer is initiated. The most significant bit is sent first. In master receive mode, reading this register initiates next byte data receiving. In slave mode, the same functions are available after an address match has occurred. Note that the Tx/Rx bit in the IBCR must correctly reflect the desired direction of transfer in master and slave modes for the transmission to begin. For instance, if the IIC is configured for master transmit but a master receive is desired, then reading the IBDR will not initiate the receive.

Reading the IBDR will return the last byte received while the IIC is configured in either master receive or slave receive modes. The IBDR does not reflect every byte that is transmitted on the IIC bus, nor can software verify that a byte has been written to the IBDR correctly by reading it back.

In master transmit mode, the first byte of data written to IBDR following assertion of $\overline{MS}/\overline{SL}$ is used for the address transfer and should comprise of the calling address (in position D7:D1) concatenated with the required R/\overline{W} bit (in position D0).

10.4 Functional Description

This section provides a complete functional description of the IICV2.

10.4.1 I-Bus Protocol

The IIC bus system uses a serial data line (SDA) and a serial clock line (SCL) for data transfer. All devices connected to it must have open drain or open collector outputs. Logic AND function is exercised on both lines with external pull-up resistors. The value of these resistors is system dependent.

Normally, a standard communication is composed of four parts: START signal, slave address transmission, data transfer and STOP signal. They are described briefly in the following sections and illustrated in [Figure 10-9](#).

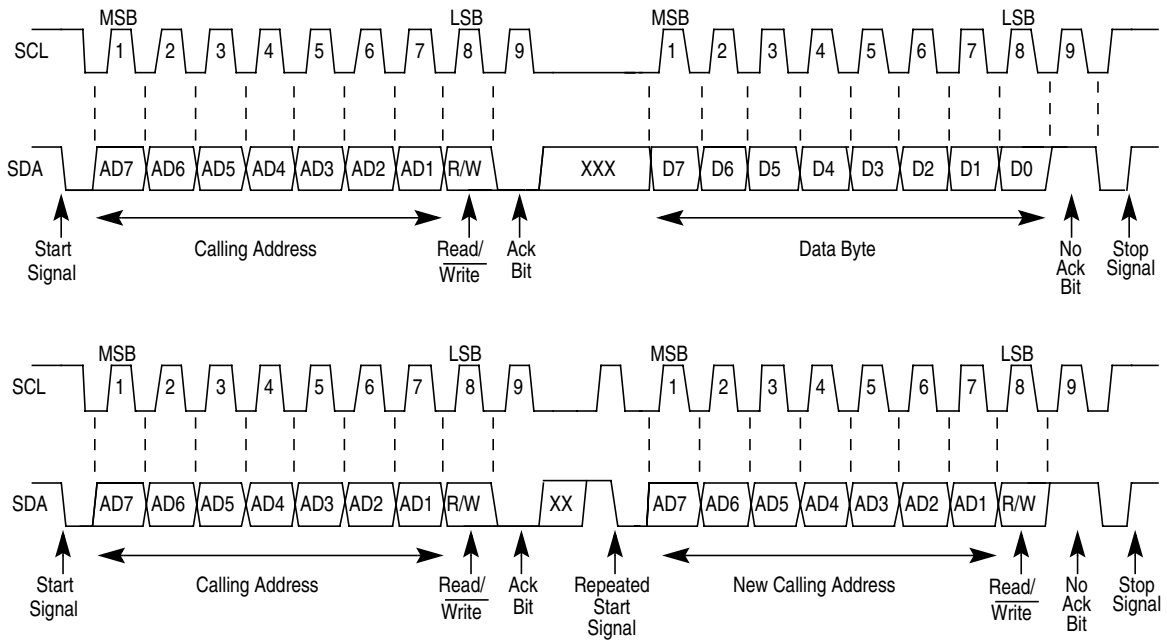

Figure 10-9. IIC-Bus Transmission Signals

10.4.1.1 START Signal

When the bus is free, i.e. no master device is engaging the bus (both SCL and SDA lines are at logical high), a master may initiate communication by sending a START signal. As shown in Figure 10-9, a START signal is defined as a high-to-low transition of SDA while SCL is high. This signal denotes the beginning of a new data transfer (each data transfer may contain several bytes of data) and brings all slaves out of their idle states.

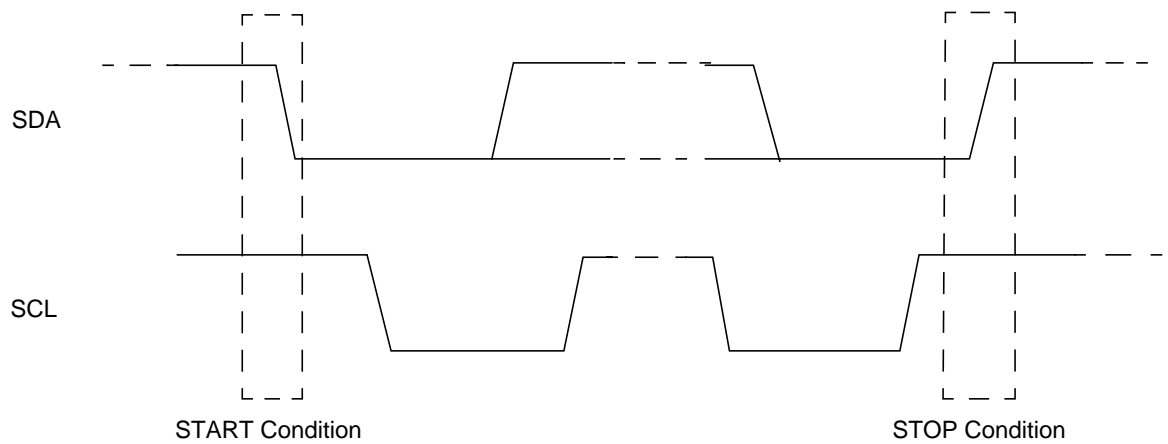

Figure 10-10. Start and Stop Conditions

10.4.1.2 Slave Address Transmission

The first byte of data transfer immediately after the START signal is the slave address transmitted by the master. This is a seven-bit calling address followed by a R/W bit. The R/W bit tells the slave the desired direction of data transfer.

1 = Read transfer, the slave transmits data to the master.

0 = Write transfer, the master transmits data to the slave.

Only the slave with a calling address that matches the one transmitted by the master will respond by sending back an acknowledge bit. This is done by pulling the SDA low at the 9th clock (see [Figure 10-9](#)).

No two slaves in the system may have the same address. If the IIC bus is master, it must not transmit an address that is equal to its own slave address. The IIC bus cannot be master and slave at the same time. However, if arbitration is lost during an address cycle the IIC bus will revert to slave mode and operate correctly even if it is being addressed by another master.

10.4.1.3 Data Transfer

As soon as successful slave addressing is achieved, the data transfer can proceed byte-by-byte in a direction specified by the R/W bit sent by the calling master

All transfers that come after an address cycle are referred to as data transfers, even if they carry sub-address information for the slave device.

Each data byte is 8 bits long. Data may be changed only while SCL is low and must be held stable while SCL is high as shown in [Figure 10-9](#). There is one clock pulse on SCL for each data bit, the MSB being transferred first. Each data byte has to be followed by an acknowledge bit, which is signalled from the receiving device by pulling the SDA low at the ninth clock. So one complete data byte transfer needs nine clock pulses.

If the slave receiver does not acknowledge the master, the SDA line must be left high by the slave. The master can then generate a stop signal to abort the data transfer or a start signal (repeated start) to commence a new calling.

If the master receiver does not acknowledge the slave transmitter after a byte transmission, it means 'end of data' to the slave, so the slave releases the SDA line for the master to generate STOP or START signal.

10.4.1.4 STOP Signal

The master can terminate the communication by generating a STOP signal to free the bus. However, the master may generate a START signal followed by a calling command without generating a STOP signal first. This is called repeated START. A STOP signal is defined as a low-to-high transition of SDA while SCL at logical 1 (see [Figure 10-9](#)).

The master can generate a STOP even if the slave has generated an acknowledge at which point the slave must release the bus.

10.4.1.5 Repeated START Signal

As shown in [Figure 10-9](#), a repeated START signal is a START signal generated without first generating a STOP signal to terminate the communication. This is used by the master to communicate with another slave or with the same slave in different mode (transmit/receive mode) without releasing the bus.

10.4.1.6 Arbitration Procedure

The Inter-IC bus is a true multi-master bus that allows more than one master to be connected on it. If two or more masters try to control the bus at the same time, a clock synchronization procedure determines the bus clock, for which the low period is equal to the longest clock low period and the high is equal to the shortest one among the masters. The relative priority of the contending masters is determined by a data arbitration procedure, a bus master loses arbitration if it transmits logic 1 while another master transmits logic 0. The losing masters immediately switch over to slave receive mode and stop driving SDA output. In this case the transition from master to slave mode does not generate a STOP condition. Meanwhile, a status bit is set by hardware to indicate loss of arbitration.

10.4.1.7 Clock Synchronization

Because wire-AND logic is performed on SCL line, a high-to-low transition on SCL line affects all the devices connected on the bus. The devices start counting their low period and as soon as a device's clock has gone low, it holds the SCL line low until the clock high state is reached. However, the change of low to high in this device clock may not change the state of the SCL line if another device clock is within its low period. Therefore, synchronized clock SCL is held low by the device with the longest low period. Devices with shorter low periods enter a high wait state during this time (see [Figure 10-10](#)). When all devices concerned have counted off their low period, the synchronized clock SCL line is released and pulled high. There is then no difference between the device clocks and the state of the SCL line and all the devices start counting their high periods. The first device to complete its high period pulls the SCL line low again.

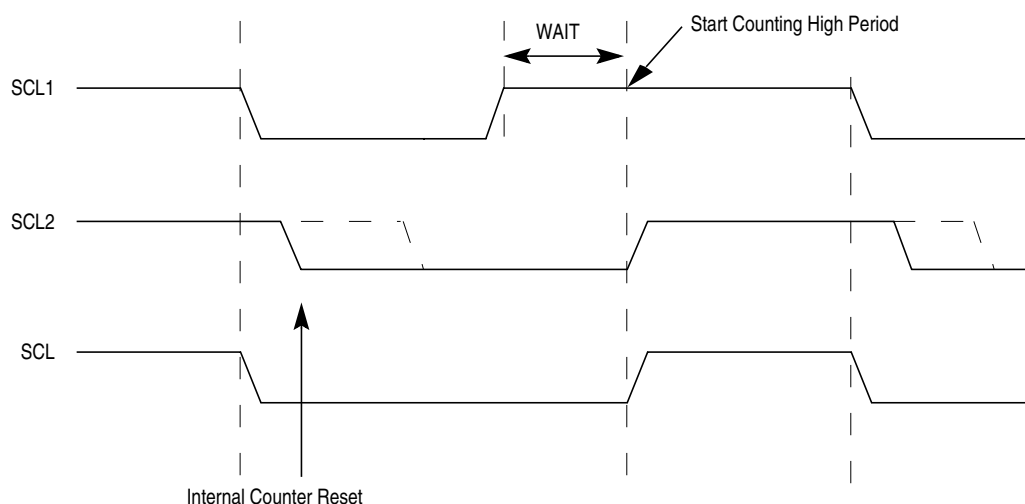

Figure 10-11. IIC-Bus Clock Synchronization

10.4.1.8 Handshaking

The clock synchronization mechanism can be used as a handshake in data transfer. Slave devices may hold the SCL low after completion of one byte transfer (9 bits). In such case, it halts the bus clock and forces the master clock into wait states until the slave releases the SCL line.

10.4.1.9 Clock Stretching

The clock synchronization mechanism can be used by slaves to slow down the bit rate of a transfer. After the master has driven SCL low the slave can drive SCL low for the required period and then release it. If the slave SCL low period is greater than the master SCL low period then the resulting SCL bus signal low period is stretched.

10.4.2 Operation in Run Mode

This is the basic mode of operation.

10.4.3 Operation in Wait Mode

IIC operation in wait mode can be configured. Depending on the state of internal bits, the IIC can operate normally when the CPU is in wait mode or the IIC clock generation can be turned off and the IIC module enters a power conservation state during wait mode. In the later case, any transmission or reception in progress stops at wait mode entry.

10.4.4 Operation in Stop Mode

The IIC is inactive in stop mode for reduced power consumption. The STOP instruction does not affect IIC register states.

10.5 Resets

The reset state of each individual bit is listed in [Section 10.3, “Memory Map and Register Definition,”](#) which details the registers and their bit-fields.

10.6 Interrupts

IICV2 uses only one interrupt vector.

Table 10-8. Interrupt Summary

Interrupt	Offset	Vector	Priority	Source	Description
IIC Interrupt	—	—	—	IBAL, TCF, IAAS bits in IBSR register	When either of IBAL, TCF or IAAS bits is set may cause an interrupt based on arbitration lost, transfer complete or address detect conditions

Internally there are three types of interrupts in IIC. The interrupt service routine can determine the interrupt type by reading the status register.

IIC Interrupt can be generated on

1. Arbitration lost condition (IBAL bit set)
2. Byte transfer condition (TCF bit set)
3. Address detect condition (IAAS bit set)

The IIC interrupt is enabled by the IBIE bit in the IIC control register. It must be cleared by writing 0 to the IBF bit in the interrupt service routine.

10.7 Initialization/Application Information

10.7.1 IIC Programming Examples

10.7.1.1 Initialization Sequence

Reset will put the IIC bus control register to its default status. Before the interface can be used to transfer serial data, an initialization procedure must be carried out, as follows:

1. Update the frequency divider register (IBFD) and select the required division ratio to obtain SCL frequency from system clock.
2. Update the IIC bus address register (IBAD) to define its slave address.
3. Set the IBEN bit of the IIC bus control register (IBCR) to enable the IIC interface system.
4. Modify the bits of the IIC bus control register (IBCR) to select master/slave mode, transmit/receive mode and interrupt enable or not.

10.7.1.2 Generation of START

After completion of the initialization procedure, serial data can be transmitted by selecting the 'master transmitter' mode. If the device is connected to a multi-master bus system, the state of the IIC bus busy bit (IBB) must be tested to check whether the serial bus is free.

If the bus is free (IBB=0), the start condition and the first byte (the slave address) can be sent. The data written to the data register comprises the slave calling address and the LSB set to indicate the direction of transfer required from the slave.

The bus free time (i.e., the time between a STOP condition and the following START condition) is built into the hardware that generates the START cycle. Depending on the relative frequencies of the system clock and the SCL period it may be necessary to wait until the IIC is busy after writing the calling address to the IBDR before proceeding with the following instructions. This is illustrated in the following example.

An example of a program which generates the START signal and transmits the first byte of data (slave address) is shown below:

```

CHFLAG      BRSET   IBSR,#$20,*      ;WAIT FOR IBB FLAG TO CLEAR
TXSTART     BSET    IBCR,#$30      ;SET TRANSMIT AND MASTER MODE;i.e. GENERATE START CONDITION
            MOVB   CALLING,IBDR    ;TRANSMIT THE CALLING ADDRESS, D0=R/W
IBFREE      BRCLR  IBSR,#$20,*      ;WAIT FOR IBB FLAG TO SET
    
```

10.7.1.3 Post-Transfer Software Response

Transmission or reception of a byte will set the data transferring bit (TCF) to 1, which indicates one byte communication is finished. The IIC bus interrupt bit (IBIF) is set also; an interrupt will be generated if the interrupt function is enabled during initialization by setting the IBIE bit. Software must clear the IBIF bit in the interrupt routine first. The TCF bit will be cleared by reading from the IIC bus data I/O register (IBDR) in receive mode or writing to IBDR in transmit mode.

Software may service the IIC I/O in the main program by monitoring the IBIF bit if the interrupt function is disabled. Note that polling should monitor the IBIF bit rather than the TCF bit because their operation is different when arbitration is lost.

Note that when an interrupt occurs at the end of the address cycle the master will always be in transmit mode, i.e. the address is transmitted. If master receive mode is required, indicated by R/W bit in IBDR, then the Tx/Rx bit should be toggled at this stage.

During slave mode address cycles (IAAS=1), the SRW bit in the status register is read to determine the direction of the subsequent transfer and the Tx/Rx bit is programmed accordingly. For slave mode data cycles (IAAS=0) the SRW bit is not valid, the Tx/Rx bit in the control register should be read to determine the direction of the current transfer.

The following is an example of a software response by a 'master transmitter' in the interrupt routine.

```

ISR      BCLR      IBSR,#$02          ;CLEAR THE IBIF FLAG
          BRCLR    IBCR,#$20,SLAVE    ;BRANCH IF IN SLAVE MODE
          BRCLR    IBCR,#$10,RECEIVE  ;BRANCH IF IN RECEIVE MODE
          BRSET    IBSR,#$01,END      ;IF NO ACK, END OF TRANSMISSION
TRANSMIT MOVB     DATABUF,IBDR       ;TRANSMIT NEXT BYTE OF DATA
    
```

10.7.1.4 Generation of STOP

A data transfer ends with a STOP signal generated by the 'master' device. A master transmitter can simply generate a STOP signal after all the data has been transmitted. The following is an example showing how a stop condition is generated by a master transmitter.

```

MASTX    TST      TXCNT              ;GET VALUE FROM THE TRANSMITTING COUNTER
          BEQ      END                ;END IF NO MORE DATA
          BRSET    IBSR,#$01,END      ;END IF NO ACK
          MOVB     DATABUF,IBDR       ;TRANSMIT NEXT BYTE OF DATA
          DEC      TXCNT              ;DECREASE THE TXCNT
          BRA      EMAXTX             ;EXIT
END      BCLR     IBCR,#$20          ;GENERATE A STOP CONDITION
EMASTX   RTI                          ;RETURN FROM INTERRUPT
    
```

If a master receiver wants to terminate a data transfer, it must inform the slave transmitter by not acknowledging the last byte of data which can be done by setting the transmit acknowledge bit (TXAK) before reading the 2nd last byte of data. Before reading the last byte of data, a STOP signal must be generated first. The following is an example showing how a STOP signal is generated by a master receiver.

MASR	DEC	RXCNT	;DECREASE THE RXCNT
	BEQ	ENMASR	;LAST BYTE TO BE READ
	MOVB	RXCNT,D1	;CHECK SECOND LAST BYTE
	DEC	D1	;TO BE READ
	BNE	NXMAR	;NOT LAST OR SECOND LAST
LAMAR	BSET	IBCR,#\$08	;SECOND LAST, DISABLE ACK
			;TRANSMITTING
	BRA	NXMAR	
ENMASR	BCLR	IBCR,#\$20	;LAST ONE, GENERATE 'STOP' SIGNAL
NXMAR	MOVB	IBDR,RXBUF	;READ DATA AND STORE
	RTI		

10.7.1.5 Generation of Repeated START

At the end of data transfer, if the master continues to want to communicate on the bus, it can generate another START signal followed by another slave address without first generating a STOP signal. A program example is as shown.

RESTART	BSET	IBCR,#\$04	;ANOTHER START (RESTART)
	MOVB	CALLING,IBDR	;TRANSMIT THE CALLING ADDRESS;D0=R/W

10.7.1.6 Slave Mode

In the slave interrupt service routine, the module addressed as slave bit (IAAS) should be tested to check if a calling of its own address has just been received. If IAAS is set, software should set the transmit/receive mode select bit (Tx/Rx bit of IBCR) according to the R/W command bit (SRW). Writing to the IBCR clears the IAAS automatically. Note that the only time IAAS is read as set is from the interrupt at the end of the address cycle where an address match occurred, interrupts resulting from subsequent data transfers will have IAAS cleared. A data transfer may now be initiated by writing information to IBDR, for slave transmits, or dummy reading from IBDR, in slave receive mode. The slave will drive SCL low in-between byte transfers, SCL is released when the IBDR is accessed in the required mode.

In slave transmitter routine, the received acknowledge bit (RXAK) must be tested before transmitting the next byte of data. Setting RXAK means an 'end of data' signal from the master receiver, after which it must be switched from transmitter mode to receiver mode by software. A dummy read then releases the SCL line so that the master can generate a STOP signal.

10.7.1.7 Arbitration Lost

If several masters try to engage the bus simultaneously, only one master wins and the others lose arbitration. The devices which lost arbitration are immediately switched to slave receive mode by the hardware. Their data output to the SDA line is stopped, but SCL continues to be generated until the end of the byte during which arbitration was lost. An interrupt occurs at the falling edge of the ninth clock of this transfer with IBAL=1 and MS/SL=0. If one master attempts to start transmission while the bus is being engaged by another master, the hardware will inhibit the transmission; switch the MS/SL bit from 1 to 0 without generating STOP condition; generate an interrupt to CPU and set the IBAL to indicate that the attempt to engage the bus is failed. When considering these cases, the slave service routine should test the IBAL first and the software should clear the IBAL bit if it is set.

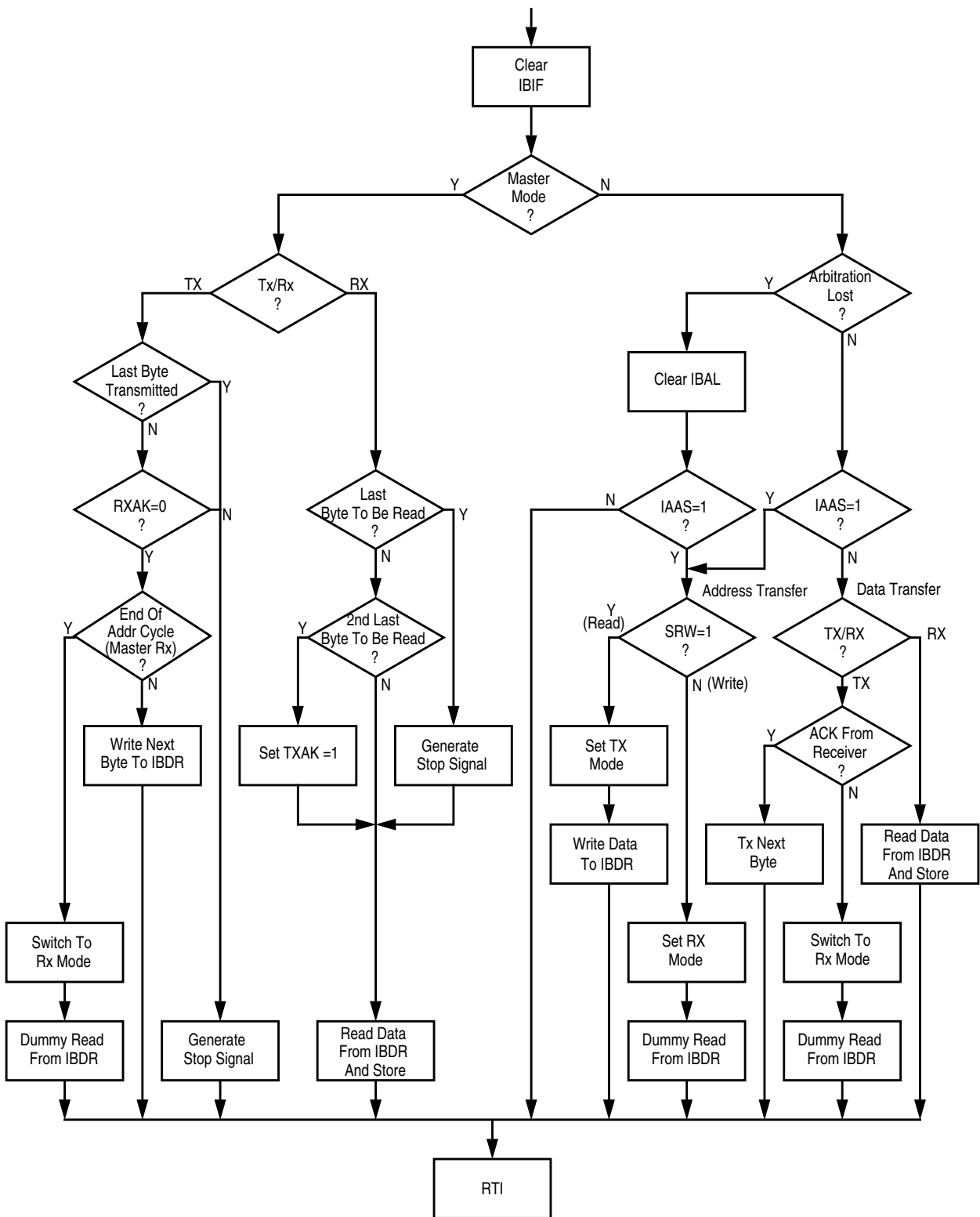

Figure 10-12. Flow-Chart of Typical IIC Interrupt Routine

Chapter 11

Pulse Width Modulator with Fault Protection (PMF15B6C) Module

Table 11-1. Revision History

Revision Number	Revision Date	Sections Affected	Description of Changes
V01.05	19 AUG 2002		Updates after review with verification team.
V02.05	15 MAY 2003		Updated version number to match clearcase label
V02.06	10 NOV 2010	11.3.2.24/11-352 11.3.2.29/11-355	Fixed PMFDTMA,PMFDTMB maximum cycle count (4096)

11.1 Introduction

The Pulse width Modulator with Fault protection (PMF) module can be configured for one, two, or three complementary pairs. For example:

- One complementary pair and four independent PWM outputs
- Two complementary pair and two independent PWM outputs
- Three complementary pair and zero independent PWM outputs
- Zero complementary pair and six independent PWM outputs

All PWM outputs can be generated from the same counter, or each pair can have its own counter for three independent PWM frequencies. Complementary operation permits programmable dead-time insertion, distortion correction through current sensing by software, and separate top and bottom output polarity control. Each counter value is programmable to support a continuously variable PWM frequency. Both edge- and center-aligned synchronous pulse width-control and full range modulation from 0 percent to 100 percent, are supported. The PMF is capable of controlling most motor types: AC induction motors (ACIM), both brushless (BLDC) and brush DC motors (BDC), switched (SRM) and variable reluctance motors (VRM), and stepper motors.

11.1.1 Features

- Three complementary PWM signal pairs, or six independent PWM signals
- Three 15-bit counters
- Features of complementary channel operation
- Deadtime insertion
- Separate top and bottom pulse width correction via current status inputs or software
- Separate top and bottom polarity control

- Edge-aligned or center-aligned PWM signals
- Half-cycle reload capability
- Integral reload rates from 1 to 16
- Individual software-controlled PWM output
- Programmable fault protection
- Polarity control

11.1.2 Modes of Operation

Care must be exercised when using this module in the modes listed in [Table 11-2](#). PWM outputs are placed in their inactive states in STOP mode, and optionally under WAIT and FREEZE modes. PWM outputs will be reactivated (assuming they were active to begin with) when these modes are exited

Table 11-2. Modes When PWM Operation is Restricted

Mode	Description
STOP	PWM outputs are disabled
WAIT	PWM outputs are disabled as a function of the PMFWAI bit.
FREEZE	PWM outputs are disabled as a function of the PMFFRZ bit.

11.1.3 Block Diagrams

[Figure 11-1](#) provides an overview of the PMF module.

The Mux/Swap/Current Sense block is tightly integrated with the dead time insertion block. This detail is shown in [Figure 11-2](#).

NOTE

It is possible to have both channels of a complementary pair to be high. For example, if the TOPNEGA (negative polarity for PWM0), BOTNEGA (negative polarity for PWM1), MASK0 and MASK1 bits are set, both the PWM complementary outputs of generator A will be high. See [Section 11.3.2.2, “PMF Configure 1 Register \(PMFCFG1\)”](#) for the description of TOPNEG and BOTNEG bits, and [Section 11.3.2.3, “PMF Configure 2 Register \(PMFCFG2\)”](#) for the description of the MSK0 and MSK1 bits.

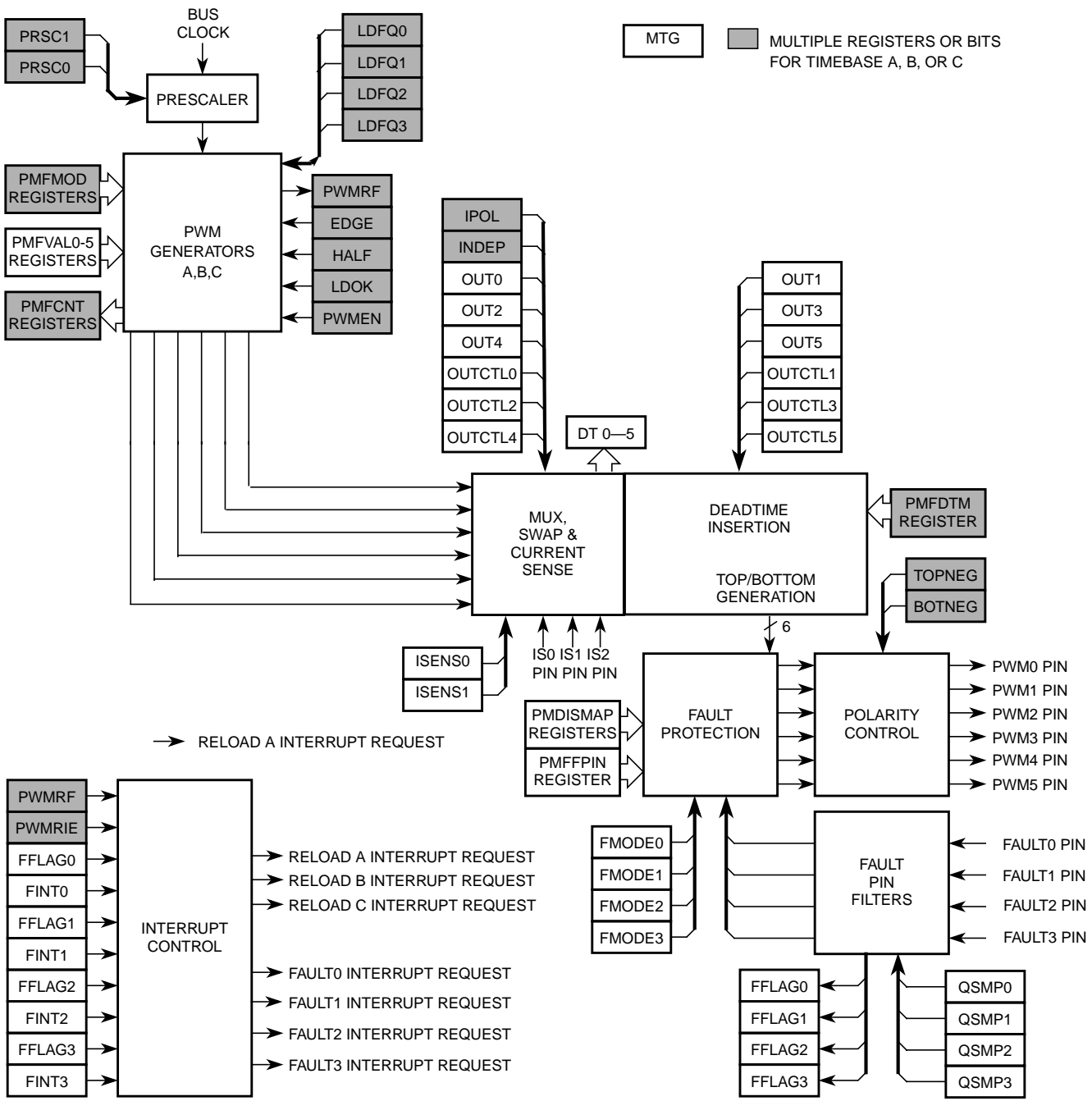

Figure 11-1. PMF Block Diagram

- PWM source selection is based on a number of factors:
- State of current sense pins
 - IPOL bit
 - OUTCTL bit
 - Center versus edge aligned

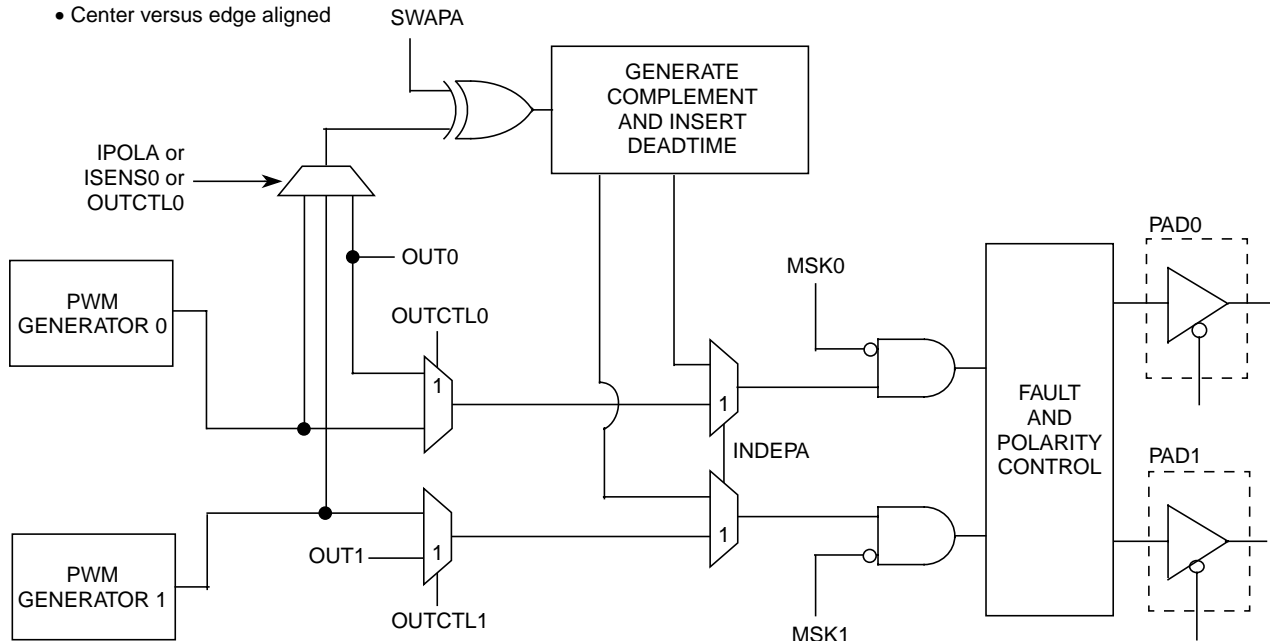

Figure 11-2. Detail of Mux, Swap, and Deadtime Functions

11.2 Signal Descriptions

The pulse width modulator has external pins named PWM0–5, FAULT0–3, and $\overline{IS0}$ – $\overline{IS2}$.

11.2.1 PWM0–PWM5 Pins

PWM0–PWM5 are the output pins of the six PWM channels.

11.2.2 FAULT0–FAULT3 Pins

FAULT0–FAULT3 are input pins for disabling selected PWM outputs.

11.2.3 $\overline{IS0}$ – $\overline{IS2}$ Pins

$\overline{IS0}$ – $\overline{IS2}$ are current status pins for top/bottom pulse width correction in complementary channel operation while deadtime is asserted.

11.3 Memory Map and Registers

11.3.1 Module Memory Map

A summary of the registers associated with the PMF module is shown in [Figure 11-3](#). Detailed descriptions of the registers and bits are given in the subsections that follow.

Address	Name		Bit 7	6	5	4	3	2	1	Bit 0
\$0000	PMFCFG0	R W	WP	MTG	EDGE C	EDGE B	EDGE A	INDEPC	INDEPB	INDEPA
\$0001	PMFCFG1	R W	ENHA	0	BOTNEGC	TOPNEGC	BOTNEGB	TOPNEGB	BOTNEGA	TOPNEGA
\$0002	PMFCFG2	R W	0	0	MSK5	MSK4	MSK3	MSK2	MSK1	MSK0
\$0003	PMFCFG3	R W	PMFWAI	PMFFRZ	0	VLMODE		SWAPC	SWAPB	SWAPA
\$0004	PMFFCTL	R W	FMODE3	FIE3	FMODE2	FIE2	FMODE1	FIE1	FMODE0	FIE0
\$0005	PMFFPIN	R W	0	FPINE3	0	FPINE2	0	FPINE1	0	FPINE0
\$0006	PMFFSTA	R W	0	FFLAG3	0	FFLAG2	0	FFLAG1	0	FFLAG0
\$0007	PMFQSMP	R W	QSMP3		QSMP2		QSMP1		QSMP0	
\$0008	PMFDMPA	R W	DMP13	DMP12	DMP11	DMP10	DMP03	DMP02	DMP01	DMP00
\$0009	PMFDMPB	R W	DMP33	DMP32	DMP31	DMP30	DMP23	DMP22	DMP21	DMP20
\$000A	PMFDMPC	R W	DMP53	DMP52	DMP51	DMP50	DMP43	DMP42	DMP41	DMP53
\$000B	Reserved	R W								
\$000C	PMFOUTC	R W	0	0	OUTCTL5	OUTCTL4	OUTCTL3	OUTCTL2	OUTCTL1	OUTCTL0
\$000D	PMFOUTB	R W	0	0	OUT5	OUT4	OUT3	OUT2	OUT1	OUT0

= Unimplemented or Reserved

Figure 11-3. Quick Reference to PMF Registers (Sheet 1 of 4)

Address	Name		Bit 7	6	5	4	3	2	1	Bit 0	
\$000E	PMFDTMS	R	0	0	DT5	DT4	DT3	DT2	DT1	DT0	
		W									
\$000F	PMFCCTL	R	0	0	ISENS		0	IPOLC	IPOLB	IPOLA	
		W									
\$0010	PMFVAL0	R	PMFVAL0								
		W									
\$0011	PMFVAL0	R	PMFVAL0								
		W									
\$0012	PMFVAL1	R	PMFVAL1								
		W									
\$0013	PMFVAL1	R	PMFVAL1								
		W									
\$0014	PMFVAL2	R	PMFVAL2								
		W									
\$0015	PMFVAL2	R	PMFVAL2								
		W									
\$0016	PMFVAL3	R	PMFVAL3								
		W									
\$0017	PMFVAL3	R	PMFVAL3								
		W									
\$0018	PMFVAL4	R	PMFVAL4								
		W									
\$0019	PMFVAL4	R	PMFVAL4								
		W									
\$001A	PMFVAL5	R	PMFVAL5								
		W									
\$001B	PMFVAL5	R	PMFVAL5								
		W									
\$001C– \$001F	Reserved	R									
		W									
\$0020	PMFENCA	R	PWMENA	0	0	0	0	0	LDOKA	PWMRIEA	
		W									
\$0021	PMFFQCA	R	LDFQA				HALFA	PRSCA	PWMRFA		
		W									

= Unimplemented or Reserved

Figure 11-3. Quick Reference to PMF Registers (Sheet 2 of 4)

Address	Name		Bit 7	6	5	4	3	2	1	Bit 0
\$0022	PMFCNTA	R	0	PMFCNTA						
		W								
\$0023	PMFCNTA	R	PMFCNTA							
		W								
\$0024	PMFMODA	R	0	PMFMODA						
		W								
\$0025	PMFMODA	R	PMFMODA							
		W								
\$0026	PMFDTMA	R	0	0	0	0	PMFDTMA			
		W								
\$0027	PMFDTMA	R	PMFDTMA							
		W								
\$0028	PMFENCB	R	PWMENB	0	0	0	0	0	LDOKB	PWMRIEB
		W								
\$0029	PMFFQCB	R	LDFQB				HALFB	PRSCB		PWMRFB
		W								
\$002A	PMFCNTB	R	0	PMFCNTB						
		W								
\$002B	PMFCNTB	R	PMFCNTB							
		W								
\$002C	PMFMOdB	R	0	PMFMOdB						
		W								
\$002D	PMFMOdB	R	PMFMOdB							
		W								
\$002E	PMFDTMB	R	0	0	0	0	PMFDTMB			
		W								
\$002F	PMFDTMB	R	PMFDTMB							
		W								
\$0030	PMFENCC	R	PWMENC	0	0	0	0	0	LDOKC	PWMRIEC
		W								
\$0031	PMFFQCC	R	LDFQC				HALFC	PRSCC		PWMRFC
		W								

= Unimplemented or Reserved

Figure 11-3. Quick Reference to PMF Registers (Sheet 3 of 4)

Address	Name		Bit 7	6	5	4	3	2	1	Bit 0
\$0032	PMFCNTC	R	0	PMFCNTC						
		W								
\$0033	PMFCNTC	R	PMFCNTC							
		W								
\$0034	PMFMODC	R	0	PMFMODC						
		W								
\$0035	PMFMODC	R	PMFMODC							
		W								
\$0036	PMFDTMC	R	0	0	0	0	PMFDTMC			
		W								
\$0037	PMFDTMC	R	PMFDTMC							
		W								
\$0038– \$003F	Reserved	R								
		W								

= Unimplemented or Reserved

Figure 11-3. Quick Reference to PMF Registers (Sheet 4 of 4)

11.3.2 Register Descriptions

The address of a register is the sum of a base address and an address offset. The base address is defined at the chip level and the address offset is defined at the module level.

11.3.2.1 PMF Configure 0 Register (PMFCFG0)

Address: \$0000

	7	6	5	4	3	2	1	0
R								
W	WP	MTG	EDGE C	EDGE B	EDGE A	INDEPC	INDEPB	INDEPA
Reset	0	0	0	0	0	0	0	0

Figure 11-4. PMF Configure 0 Register (PMFCFG0)

Read anytime. See bit description for write conditions.

Table 11-3. PMFCFG0 Field Descriptions

Field	Description
7 WP	<p>Write Protect — This bit enables write protection to be used for all write-protectable registers. While clear, WP allows write-protected registers to be written. When set, WP prevents any further writes to write-protected registers. Once set, WP can be cleared only by reset.</p> <p>0 Write-protectable registers may be written. 1 Write-protectable registers are write-protected.</p>

Table 11-3. PMFCFG0 Field Descriptions (continued)

Field	Description
6 MTG	<p>Multiple Timebase Generators — This bit determines the number of timebase counters used. Once set, MTG can be cleared only by reset.</p> <p>If MTG is set, PWM generators B and C and registers \$0028 – \$0037 are available. The three generators have their own variable frequencies and are not synchronized.</p> <p>If MTG is cleared, PMF registers from \$0028 – \$0037 can not be written and read zeroes, and bits EDGEA and EDGEB are ignored. Pair A, Pair B and Pair C PWMs are synchronized to PWM generator A and use registers from \$0020 – \$0027.</p> <p>0 Single timebase generator. 1 Multiple timebase generators.</p>
5 EDGEA	<p>Edge-Aligned or Center-Aligned PWM for Pair C — This bit determines whether PWM4 and PWM5 channels will use edge-aligned or center-aligned waveforms. This bit has no effect if MTG bit is cleared. This bit cannot be modified after the WP bit is set.</p> <p>0 PWM4 and PWM5 are center-aligned PWMs 1 PWM4 and PWM5 are edge-aligned PWMs</p>
4 EDGEB	<p>Edge-Aligned or Center-Aligned PWM for Pair B — This bit determines whether PWM2 and PWM3 channels will use edge-aligned or center-aligned waveforms. This bit has no effect if MTG bit is cleared. This bit cannot be modified after the WP bit is set.</p> <p>0 PWM2 and PWM3 are center-aligned PWMs 1 PWM2 and PWM3 are edge-aligned PWMs</p>
3 EDGEA	<p>Edge-Aligned or Center-Aligned PWM for Pair A— This bit determines whether PWM0 and PWM1 channels will use edge-aligned or center-aligned waveforms. It determines waveforms for Pair B and Pair C if the MTG bit is cleared. This bit cannot be modified after the WP bit is set.</p> <p>0 PWM0 and PWM1 are center-aligned PWMs 1 PWM0 and PWM1 are edge-aligned PWMs</p>
2 INDEPC	<p>Independent or Complimentary Operation for Pair C— This bit determines if the PWM channels 4 and 5 will be independent PWMs or complimentary PWMs. This bit cannot be modified after the WP bit is set.</p> <p>0 PWM4 and PWM5 are complimentary PWM pair 1 PWM4 and PWM5 are independent PWMs</p>
1 INDEPB	<p>Independent or Complimentary Operation for Pair B— This bit determines if the PWM channels 2 and 3 will be independent PWMs or complimentary PWMs. This bit cannot be modified after the WP bit is set.</p> <p>0 PWM2 and PWM3 are complimentary PWM pair 1 PWM2 and PWM3 are independent PWMs</p>
0 INDEPA	<p>Independent or Complimentary Operation for Pair A— This bit determines if the PWM channels 0 and 1 will be independent PWMs or complimentary PWMs. This bit cannot be modified after the WP bit is set.</p> <p>0 PWM0 and PWM1 are complimentary PWM pair 1 PWM0 and PWM1 are independent PWMs</p>

11.3.2.2 PMF Configure 1 Register (PMFCFG1)

Address: \$0001

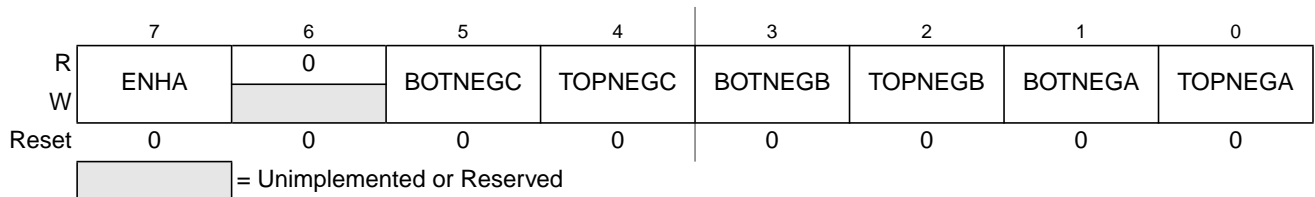

Figure 11-5. PMF Configure 1 Register (PMFCFG1)

Read anytime. This register cannot be modified after the WP bit is set.

A normal PWM output or positive polarity means that the PWM channel outputs high when the counter value is smaller than or equal to the pulse width value and outputs low otherwise. An inverted output or negative polarity means that the PWM channel outputs low when the counter value is smaller than or equal to the pulse width value and outputs high otherwise.

Table 11-4. PMFCFG1 Field Descriptions

Field	Description
7 ENHA	Enable Hardware Acceleration — This bit enables writing to the VLMODE[1:0], SWAPC, SWAPB, and SWAPA bits in the PMFCFG3 register. This bit cannot be modified after the WP bit is set. 0 Disable writing to VLMODE[1:0], SWAPC, SWAPB, and SWAPA bits 1 Enable writing to VLMODE[1:0], SWAPC, SWAPB, and SWAPA bits
5 BOTNEGC	Pair C Bottom-Side PWM Polarity — This bit determines the polarity for Pair C bottom-side PWM (PWM5). This bit cannot be modified after the WP bit is set. 0 Positive PWM5 polarity 1 Negative PWM5 polarity
4 TOPNEGC	Pair C Top-Side PWM Polarity — This bit determines the polarity for Pair C top-side PWM (PWM4). This bit cannot be modified after the WP bit is set. 0 Positive PWM4 polarity 1 Negative PWM4 polarity
3 BOTNEGB	Pair B Bottom-Side PWM Polarity — This bit determines the polarity for Pair B bottom-side PWM (PWM3). This bit cannot be modified after the WP bit is set. 0 Positive PWM3 polarity 1 Negative PWM3 polarity
2 TOPNEGB	Pair B Top-Side PWM Polarity — This bit determines the polarity for Pair B top-side PWM (PWM2). This bit cannot be modified after the WP bit is set. 0 Positive PWM2 polarity 1 Negative PWM2 polarity
1 BOTNEGA	Pair A Bottom-Side PWM Polarity — This bit determines the polarity for Pair A bottom-side PWM (PWM1). This bit cannot be modified after the WP bit is set. 0 Positive PWM1 polarity 1 Negative PWM1 polarity
0 TOPNEGA	Pair A Top-Side PWM Polarity — This bit determines the polarity for Pair A top-side PWM (PWM0). This bit cannot be modified after the WP bit is set. 0 Positive PWM0 polarity 1 Negative PWM0 polarity

11.3.2.3 PMF Configure 2 Register (PMFCFG2)

Address: \$0002

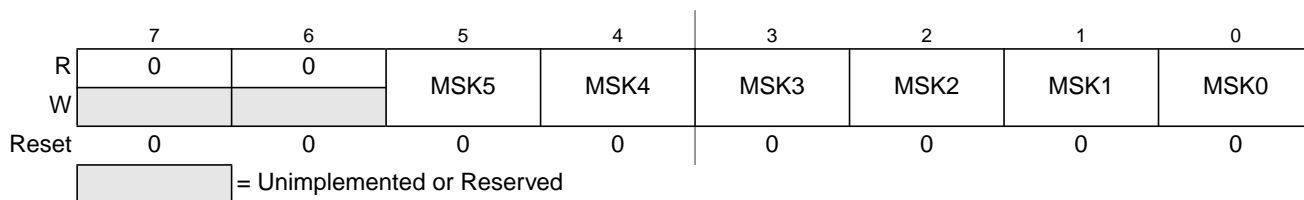

Figure 11-6. PMF Configure 2 Register (PMFCFG2)

Read and write anytime.

Table 11-5. PMFCFG2 Field Descriptions

Field	Description
5–0 MSK[5:0]	Mask PWMx 0 PWMx is unmasked. 1 PWMx is masked and the channel is set to a value of 0 percent duty cycle. where x is 0, 1, 2, 3, 4, and 5

CAUTION

When using the TOPNEG/BOTNEG bits and the MSKx bits at the same time, when in complementary mode, it is possible to have both PMF channel outputs of a channel pair set to one.

11.3.2.4 PMF Configure 3 Register (PMFCFG3)

Address: \$0003

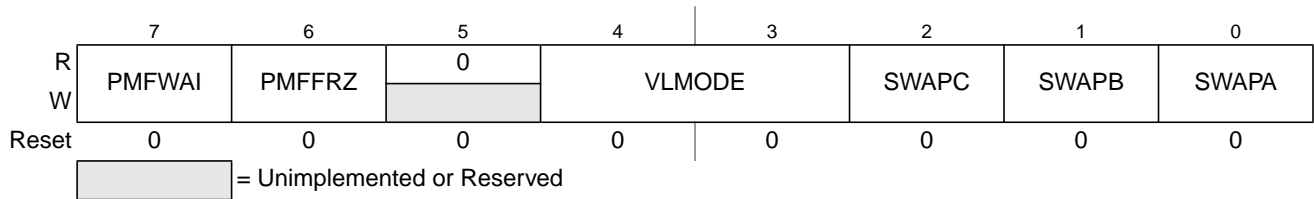

Figure 11-7. PMF Configure 3 Register (PMFCFG3)

Read and write anytime.

Table 11-6. PMFCFG3 Field Descriptions

Field	Description
7 PMFWAI	PMF Stops While in WAIT Mode — When set to zero, the PWM generators will continue to run while the chip is in WAIT mode. In this mode, the peripheral clock continues to run but the CPU clock does not. If the device enters WAIT mode and this bit is one, then the PWM outputs will be switched to their inactive state until WAIT mode is exited. At that point the PWM pins will resume operation as programmed in the PWM registers. 0 PMF continues to run in WAIT mode. 1 PMF is disabled in WAIT mode.
6 PMFFRZ	PMF Stops While in FREEZE Mode — When set to zero, the PWM generators will continue to run while the chip is in FREEZE mode. If the device enters FREEZE mode and this bit is one, then the PWM outputs will be switched to their inactive state until FREEZE mode is exited. At that point the PWM pins will resume operation as programmed in the PWM registers. 0 PMF continues to run in FREEZE mode. 1 PMF is disabled in FREEZE mode.
4–3 VLMODE	Value Register Load Mode — This field determines the way the value registers are being loaded. This field can only be written if ENHA is set. 00 Each value register is accessed independently 01 Writing to value register zero also writes to value registers one to five 10 Writing to value register zero also writes to value registers one to three 11 Reserved (defaults to independent access)

Table 11-6. PMFCFG3 Field Descriptions (continued)

Field	Description
2 SWAPC	Swap Pair C — This bit can only be written if ENHA is set. 0 No swap. 1 PWM4 and PWM5 are swapped only in complementary mode.
1 SWAPB	Swap Pair B — This bit can only be written if ENHA is set. 0 No swap. 1 PWM2 and PWM3 are swapped only in complementary mode.
0 SWAPA	Swap Pair A — This bit can only be written if ENHA is set. 0 No swap. 1 PWM0 and PWM1 are swapped only in complementary mode.

11.3.2.5 PMF Fault Control Register (PMFFCTL)

Address: \$0004

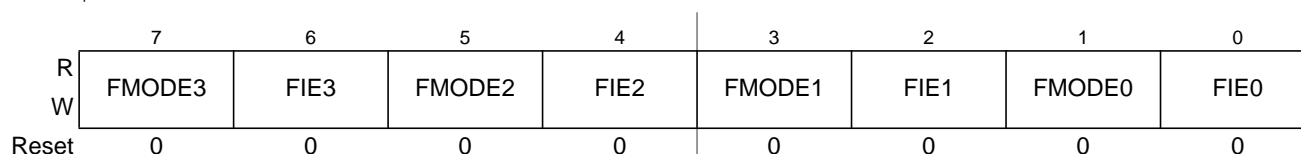

Figure 11-8. PMF Fault Control Register (PMFFCTL)

Read and write anytime.

Table 11-7. PMFFCTL Field Descriptions

Field	Description
7, 5, 3, 1 FMODE[3:0]	Fault x Pin Clearing Mode — This bit selects automatic or manual clearing of FAULTx pin faults. See Section 11.4.8.2, “Automatic Fault Clearing” and Section 11.4.8.3, “Manual Fault Clearing” for more details. 0 Manual fault clearing of FAULTx pin faults. 1 Automatic fault clearing of FAULTx pin faults. where x is 0, 1, 2 and 3.
6, 4, 2, 0 FIE[3:0]	Fault x Pin Interrupt Enable — This bit enables CPU interrupt requests to be generated by the FAULTx pin. The fault protection circuit is independent of the FIE _x bit and is active when FPIN _x is set. If a fault is detected, the PWM pins are disabled according to the PMF Disable Mapping registers. 0 Fault x CPU interrupt requests disabled. 1 Fault x CPU interrupt requests enabled. where x is 0, 1, 2 and 3.

11.3.2.6 PMF Fault Pin Enable Register (PMFFPIN)

Address: \$0005

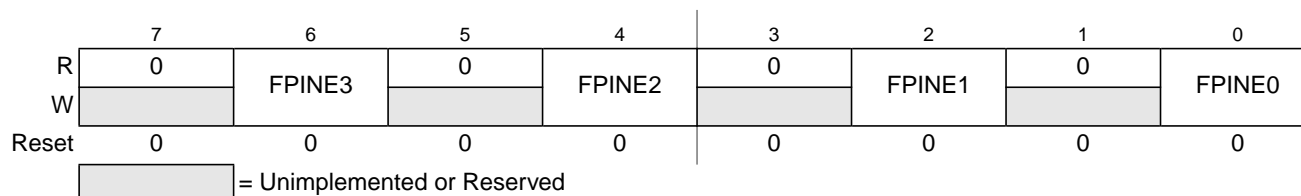

Figure 11-9. PMF Fault Pin Enable Register (PMFFPIN)

Read anytime. This register cannot be modified after the WP bit is set.

Table 11-8. PMFFPIN Field Descriptions

Field	Description
6, 4, 2, 0 FPINE[3:0]	Fault x Pin Enable 0 FAULTx pin is disabled for fault protection. 1 FAULTx pin is enabled for fault protection. where x is 0, 1, 2 and 3

11.3.2.7 PMF Fault Status Register (PMFFSTA)

Address: \$0006

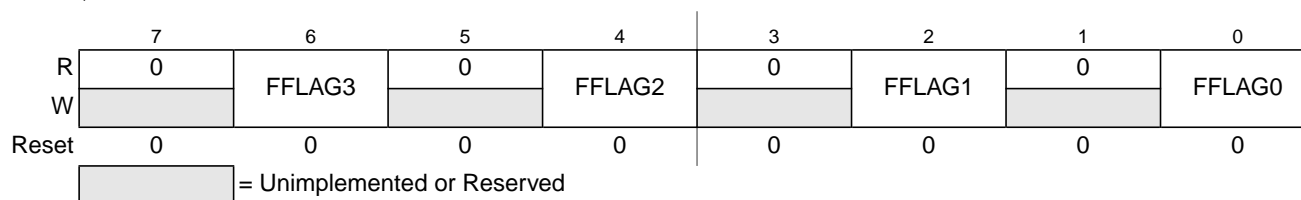

Figure 11-10. PMF Fault Flag Register (PMFFSTA)

Read and write anytime.

Table 11-9. PMFFSTA Field Descriptions

Field	Description
6, 4, 2, 0 FFLAG[3:0]	Fault x pin Flag — This flag is set after the required number of samples have been detected after a rising edge on the FAULTx pin. Writing a logic one to FFLAGx clears it. Writing a logic zero has no effect. The fault protection is enabled when FPINEx is set even when the PWMs are not enabled; therefore, a fault will be latched in, requiring to be cleared in order to prevent an interrupt. 0 No fault on the FAULTx pin. 1 Fault on the FAULTx pin. Note: Clearing FFLAGx satisfies pending FFLAGx CPU interrupt requests. where x is 0, 1, 2 and 3

11.3.2.8 PMF Fault Qualifying Samples Register (PMFQSMP)

Address: \$0007

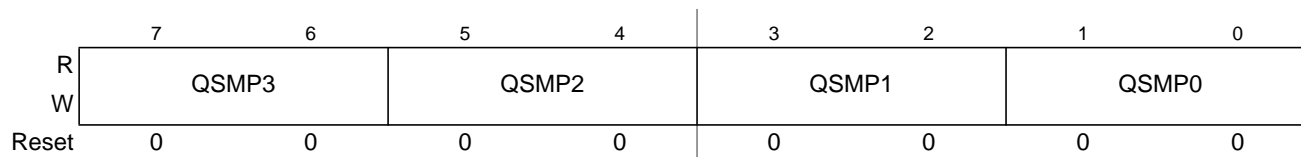

Figure 11-11. PMF Fault Qualifying Samples Register (PMFQSMP)

Read anytime. This register cannot be modified after the WP bit is set.

Table 11-10. PMFQSMP Field Descriptions

Field	Description
7–0 QSMP[3:0]	Fault x Qualifying Samples — This field indicates the number of consecutive samples taken at the FAULTx pin to determine if a fault is detected. The first sample is qualified after two bus cycles from the time the fault is present and each sample after that is taken every four bus cycles. See Table 11-11 , where x is 0, 1, 2 and 3

Table 11-11. Qualifying Samples

QSMPx	Number of Samples
00	1 sample ⁽¹⁾
01	5 samples
10	10 samples
11	15 samples

1. There is an asynchronous path from fault pin to disable PWMs immediately but the fault is qualified in two bus cycles.

11.3.2.9 PMF Disable Mapping Registers

Address: \$0008

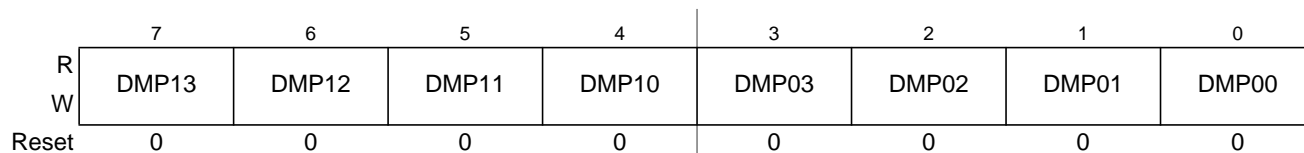

Figure 11-12. PMF Disable Mapping A Register (PMFDMPA)

Address: \$0009

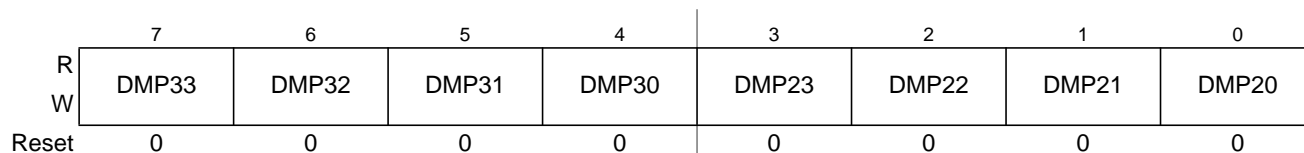

Figure 11-13. PMF Disable Mapping B Register (PMFDMPB)

Address: \$000A

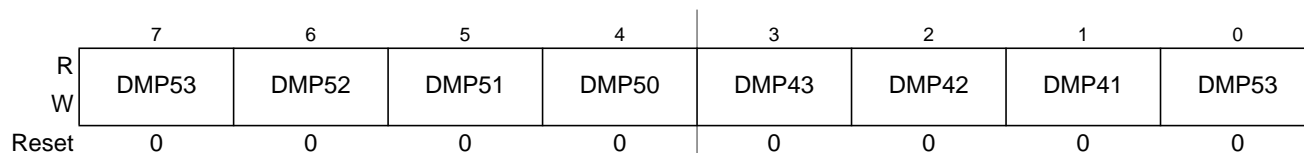

Figure 11-14. PMF Disable Mapping C Register (PMFDMPC)

Read anytime. These registers cannot be modified after the WP bit is set.

The fault decoder disables PWM pins selected by the fault logic and the disable mapping registers. See [Figure 11-15](#). Each bank of four bits in the disable mapping registers control the mapping of a single PWM pin. Refer to [Table 11-12](#).

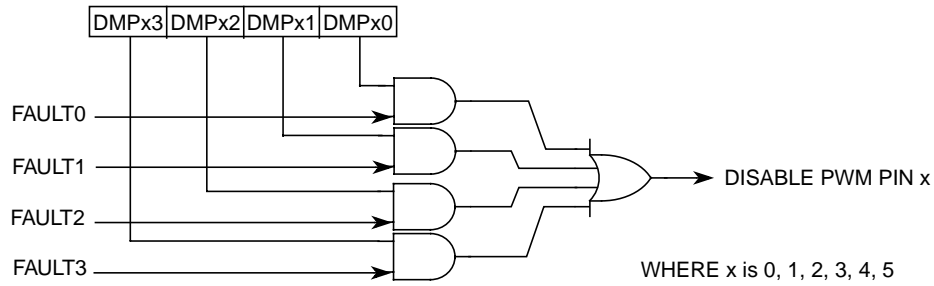

Figure 11-15. Fault Decoder

Table 11-12. Fault Mapping

PWM Pin	Controlling Register Bits
PWM0	DMP03 – DMP00
PWM1	DMP13 – DMP10
PWM2	DMP23 – DMP20
PWM3	DMP33 – DMP30
PWM4	DMP43 – DMP40
PWM5	DMP53 – DMP50

11.3.2.10 PMF Output Control Register (PMFOUTC)

Address: \$000C

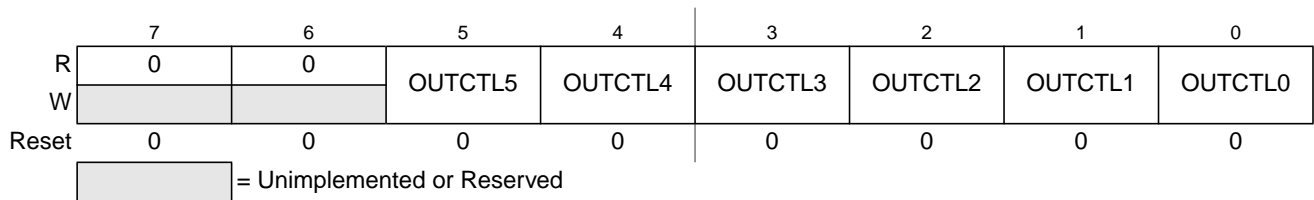

Figure 11-16. PMF Output Control Register (PMFOUTC)

Read and write anytime.

Table 11-13. PMFOUTC Field Descriptions

Field	Description
5–0 OUTCTL[5:0]	<p>OUTCTLx Bits — These bits enable software control of their corresponding PWM pin. When OUTCTLx is set, the OUTx bit activates and deactivates the PWMx output.</p> <p>When operating the PWM in complementary mode, these bits must be switched in pairs for proper operation. That is OUTCTL0 and OUTCTL1 must have the same value; OUTCTL2 and OUTCTL3 must have the same value; and OUTCTL4 and OUTCTL5 must have the same value.</p> <p>0 Software control disabled 1 Software control enabled where X is 0, 1, 2, 3, 4 and 5</p>

11.3.2.11 PMF Output Control Bit Register (PMFOUTB)

Address: \$000D

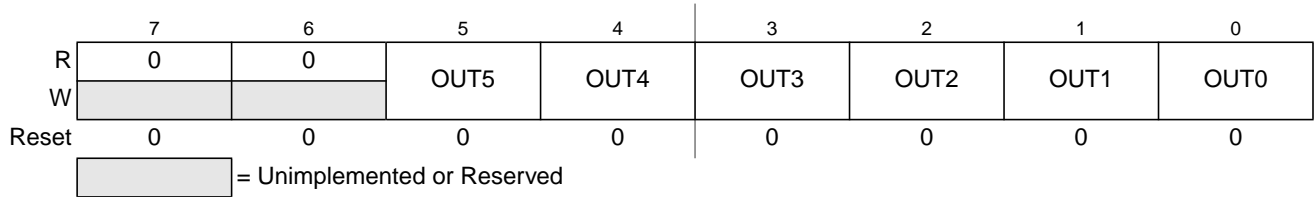

Figure 11-17. PMF Output Control Bit Register (PMFOUTB)

Read and write anytime.

Table 11-14. PMFOUTB Field Descriptions

Field	Description
5-0 OUT[5:0]	OUT Bits — When the corresponding OUTCTL bit is set, these bits control the PWM pins, illustrated in Table 11-15 .

Table 11-15. Software Output Control

OUTx Bit	Complementary Channel Operation	Independent Channel Operation
OUT0	1 — PWM0 is active 0 — PWM0 is inactive	1 — PWM0 is active 0 — PWM0 is inactive
OUT1	1 — PWM1 is complement of PWM0 0 — PWM1 is inactive	1 — PWM1 is active 0 — PWM1 is inactive
OUT2	1 — PWM2 is active 0 — PWM2 is inactive	1 — PWM2 is active 0 — PWM2 is inactive
OUT3	1 — PWM3 is complement of PWM2 0 — PWM3 is inactive	1 — PWM3 is active 0 — PWM3 is inactive
OUT4	1 — PWM4 is active 0 — PWM4 is inactive	1 — PWM4 is active 0 — PWM4 is inactive
OUT5	1 — PWM5 is complement of PWM4 0 — PWM5 is inactive	1 — PWM5 is active 0 — PWM5 is inactive

11.3.2.12 PMF Deadtime Sample Register (PMFDTMS)

Address: \$000E

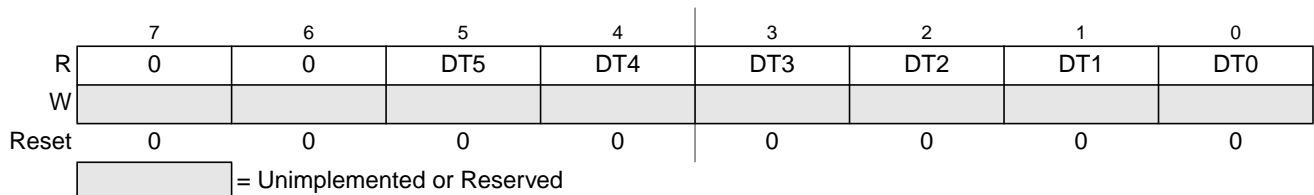

Figure 11-18. PMF Deadtime Sample Register (PMFDTMS)

Read anytime and writes have no effect.

Table 11-16. PMFDTMS Field Descriptions

Field	Description
5–0 DT[5:0]	DTx Bits — The DTx bits are grouped in pairs, DT0 and DT1, DT2 and DT3, DT4 and DT5. Each pair reflects the corresponding \overline{IS}_x pin value as sampled at the end of deadtime.

11.3.2.13 PMF Correction Control Register (PMFCCTL)

Address: \$000F

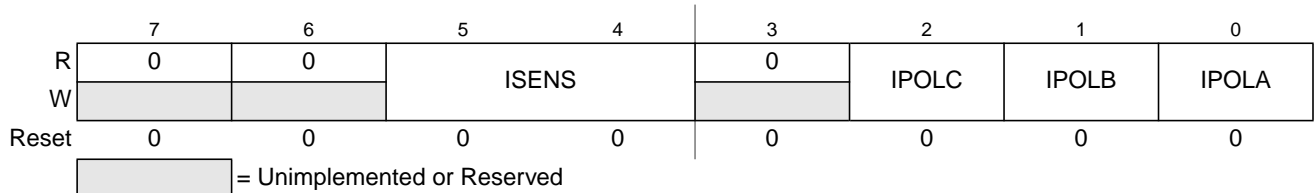
Figure 11-19. PMF Correction Control Register (PMFCCTL)

Read and write anytime.

Table 11-17. PMFCCTL Field Descriptions

Field	Description
5–4 ISENS	Current Status Sensing Method — This field selects the top/bottom correction scheme, illustrated in Table 11-18 . Note: Assume the user will provide current sensing circuitry causing the voltage at the corresponding input pin to be low for positive current and high for negative current. In addition, it assumes the top PWMs are PWM 0, 2, and 4 while the bottom PWMs are PWM 1, 3, and 5. Note: The ISENS bits are not buffered. Changing the current status sensing method can affect the present PWM cycle.
2 IPOLC	Current Polarity — This buffered bit selects the PMF Value register for the PWM4 and PWM5 pins in top/bottom software correction in complementary mode. 0 PMF Value 4 register in next PWM cycle. 1 PMF Value 5 register in next PWM cycle.
1 IPOLB	Current Polarity — This buffered bit selects the PMF Value register for the PWM2 and PWM3 pins in top/bottom software correction in complementary mode. 0 PMF Value 2 register in next PWM cycle. 1 PMF Value 3 register in next PWM cycle.
0 IPOLA	Current Polarity — This buffered bit selects the PMF Value register for the PWM0 and PWM1 pins in top/bottom software correction in complementary mode. 0 PMF Value 0 register in next PWM cycle. 1 PMF Value 1 register in next PWM cycle.

Table 11-18. Correction Method Selection

ISENS	Correction Method
00	No correction ⁽¹⁾
01	Manual correction
10	Current status sample correction on pins \overline{IS}_0 , \overline{IS}_1 , and \overline{IS}_2 during deadtime ⁽²⁾

Table 11-18. Correction Method Selection

ISENS	Correction Method
11	Current status sample on pins $\overline{IS0}$, $\overline{IS1}$, and $\overline{IS2}^{(3)}$ At the half cycle in center-aligned operation At the end of the cycle in edge-aligned operation

1. The current status pins can be used as general purpose input/output ports.
2. The polarity of the \overline{ISx} pin is latched when both the top and bottom PWMs are off. At the 0% and 100% duty cycle boundaries, there is no deadtime, so no new current value is sensed.
3. Current is sensed even with 0% or 100% duty cycle.

NOTE

The IPOLx bits take effect at the beginning of the next load cycle, regardless of the state of the load okay bit, LDOK. Select top/bottom software correction by writing 01 to the current select bits, ISENS[1:0], in the PWM control register. Reading the IPOLx bits read the buffered value and not necessarily the value currently in effect.

11.3.2.14 PMF Value 0 Register (PMFVAL0)

Address: \$0010

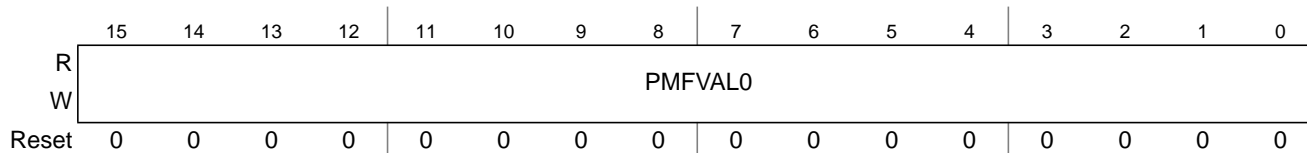

Figure 11-20. PMF Value 0 Register (PMFVAL0)

Read and write anytime.

Table 11-19. PMFVAL0 Field Descriptions

Field	Description
15–0 PMFVAL0	PMF Value 0 Bits — The 16-bit signed value in this buffered register is the pulse width in PWM0 clock period. A value less than or equal to zero deactivates the PWM output for the entire PWM period. A value greater than, or equal to the modulus, activates the PWM output for the entire PWM period. See Table 11-37 . The terms activate and deactivate refer to the high and low logic states of the PWM output. Note: PMFVAL0 is buffered. The value written does not take effect until the LDOK bit is set and the next PWM load cycle begins. Reading PMFVAL0 reads the value in the buffer and not necessarily the value the PWM generator is currently using.

11.3.2.15 PMF Value 1 Register (PMFVAL1)

Address: \$0012

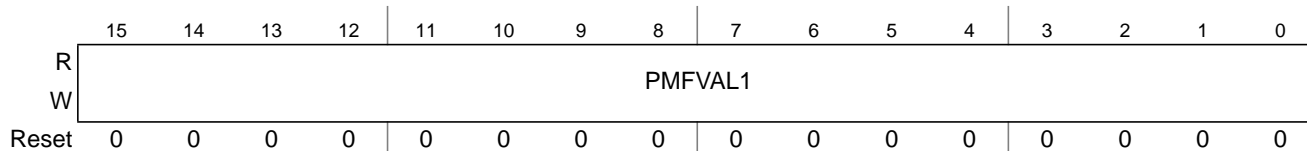

Figure 11-21. PMF Value 1 Register (PMFVAL1)

Read and write anytime.

Table 11-20. PMFVAL1 Field Descriptions

Field	Description
15–0 PMFVAL1	<p>PMF Value 1 Bits — The 16-bit signed value in this buffered register is the pulse width in PWM1 clock period. A value less than or equal to zero deactivates the PWM output for the entire PWM period. A value greater than, or equal to the modulus, activates the PWM output for the entire PWM period. See Table 11-37. The terms activate and deactivate refer to the high and low logic states of the PWM output.</p> <p>Note: PMFVAL1 is buffered. The value written does not take effect until the LDOK bit is set and the next PWM load cycle begins. Reading PMFVAL1 reads the value in the buffer and not necessarily the value the PWM generator is currently using.</p>

11.3.2.16 PMF Value 2 Register (PMFVAL2)

Address: \$0014

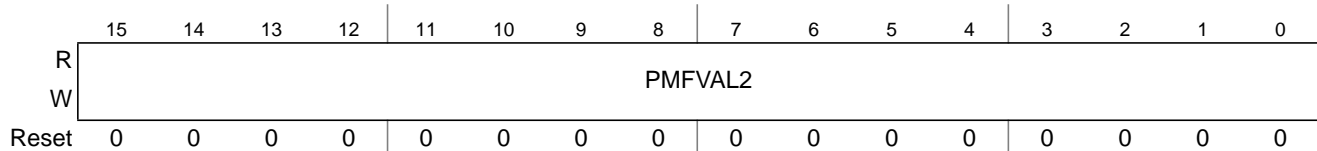

Figure 11-22. PMF Value 2 Register (PMFVAL2)

Read and write anytime.

Table 11-21. PMFVAL2 Field Descriptions

Field	Description
15–0 PMFVAL2	<p>PMF Value 2 Bits — The 16-bit signed value in this buffered register is the pulse width in PWM2 clock period. A value less than or equal to zero deactivates the PWM output for the entire PWM period. A value greater than, or equal to the modulus, activates the PWM output for the entire PWM period. See Table 11-37. The terms activate and deactivate refer to the high and low logic states of the PWM output.</p> <p>Note: PMFVAL2 is buffered. The value written does not take effect until the LDOK bit is set and the next PWM load cycle begins. Reading PMFVAL2 reads the value in the buffer and not necessarily the value the PWM generator is currently using.</p>

11.3.2.17 PMF Value 3 Register (PMFVAL3)

Address: \$0016

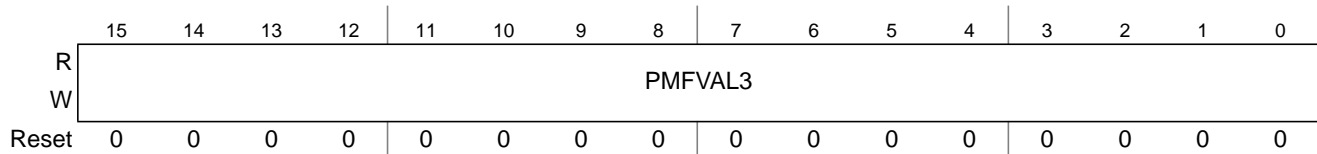

Figure 11-23. PMF Value 3 Register (PMFVAL3)

Read and write anytime.

Table 11-22. PMFVAL3 Field Descriptions

Field	Description
15–0 PMFVAL3	<p>PMF Value 3 Bits — The 16-bit signed value in this buffered register is the pulse width in PWM3 clock period. A value less than or equal to zero deactivates the PWM output for the entire PWM period. A value greater than, or equal to the modulus, activates the PWM output for the entire PWM period. See Table 11-37. The terms activate and deactivate refer to the high and low logic states of the PWM output.</p> <p>Note: PMFVAL3 is buffered. The value written does not take effect until the LDOK bit is set and the next PWM load cycle begins. Reading PMFVAL3 reads the value in the buffer and not necessarily the value the PWM generator is currently using.</p>

11.3.2.18 PMF Value 4 Register (PMFVAL4)

Address: \$0018

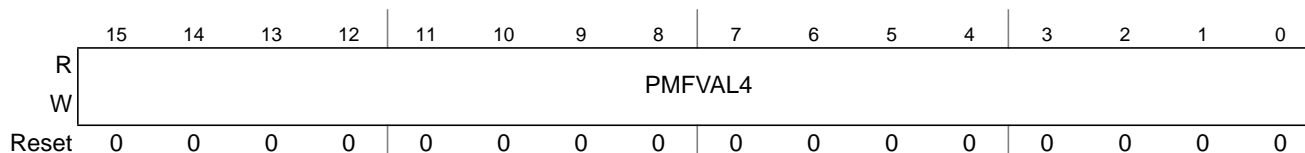

Figure 11-24. PMF Value 4 Register (PMFVAL4)

Read and write anytime.

Table 11-23. PMFVAL4 Field Descriptions

Field	Description
15–0 PMFVAL4	<p>PMF Value 4 Bits — The 16-bit signed value in this buffered register is the pulse width in PWM4 clock period. A value less than or equal to zero deactivates the PWM output for the entire PWM period. A value greater than, or equal to the modulus, activates the PWM output for the entire PWM period. See Table 11-37. The terms activate and deactivate refer to the high and low logic states of the PWM output.</p> <p>Note: PMFVAL4 is buffered. The value written does not take effect until the LDOK bit is set and the next PWM load cycle begins. Reading PMFVAL4 reads the value in the buffer and not necessarily the value the PWM generator is currently using.</p>

11.3.2.19 PMF Value 5 Register (PMFVAL5)

Address: \$001A

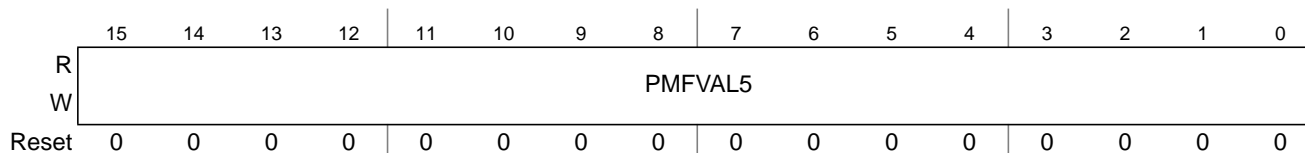

Figure 11-25. PMF Value 5 Register (PMFVAL5)

Read and write anytime.

Table 11-24. PMFVAL5 Field Descriptions

Field	Description
15–0 PMFVAL5	<p>PMF Value 5 Bits — The 16-bit signed value in this buffered register is the pulse width in PWM5 clock period. A value less than or equal to zero deactivates the PWM output for the entire PWM period. A value greater than, or equal to the modulus, activates the PWM output for the entire PWM period. See Table 11-37. The terms activate and deactivate refer to the high and low logic states of the PWM output.</p> <p>Note: PMFVAL5 is buffered. The value written does not take effect until the LDOK bit is set and the next PWM load cycle begins. Reading PMFVAL5 reads the value in the buffer and not necessarily the value the PWM generator is currently using.</p>

11.3.2.20 PMF Enable Control A Register (PMFENCA)

Address: \$0020

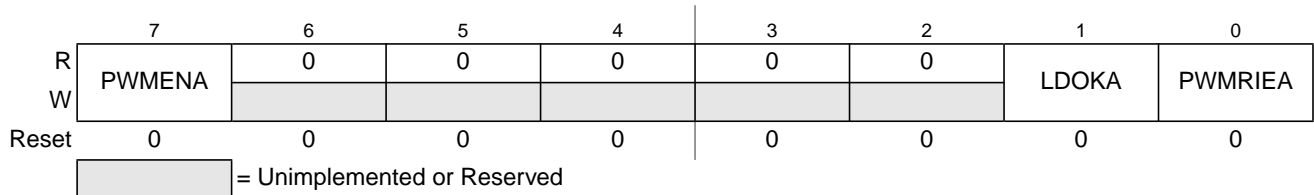

Figure 11-26. PMF Enable Control A Register (PMFENCA)

Read and write anytime.

Table 11-25. PMFENCA Field Descriptions

Field	Description
7 PWMENA	<p>PWM Generator A Enable — When MTG is clear, this bit when set enables the PWM generators A, B and C and the PWM0–5 pins. When PWMENA is clear, PWM generators A, B and C are disabled, and the PWM0–5 pins are in their inactive states unless the corresponding OUTCTLx bits are set.</p> <p>When MTG is set, this bit when set enables the PWM generator A and the PWM0 and PWM1 pins. When PWMENA is clear, the PWM generator A is disabled and PWM0 and PWM1 pins are in their inactive states unless the OUTCTL0 and OUTCTL1 bits are set.</p> <p>0 PWM generator A and PWM0-1 (2–5 if MTG = 0) pins disabled unless the respective OUTCTL bit is set. 1 PWM generator A and PWM0-1 (2–5 if MTG = 0) pins enabled.</p>
1 LDOKA	<p>Load Okay A — When MTG is clear, this bit allows loads of the PRSCA bits, the PMFMODA register and the PWMVAL0-5 registers into a set of buffers. The buffered prescaler A divisor, PWM counter modulus A value, and all PWM pulse widths take effect at the next PWM reload.</p> <p>When MTG is set, this bit allows loads of the PRSCA bits, the PMFMODA register and the PWMVAL0–1 registers into a set of buffers. The buffered prescaler divisor A, PWM counter modulus A value, PWM0–1 pulse widths take effect at the next PWM reload.</p> <p>Set LDOKA by reading it when it is logic zero and then writing a logic one to it. LDOKA is automatically cleared after the new values are loaded, or can be manually cleared before a reload by writing a logic zero to it. Reset clears LDOKA.</p> <p>0 Do not load new modulus A, prescaler A, and PWM0–1 (2–5 if MTG = 0) values 1 Load prescaler A, modulus A, and PWM0–1 (2–5 if MTG = 0) values</p> <p>Note: Do not set PWMENA bit before setting the LDOKA bit and do not clear the LDOKA bit at the same time as setting the PWMENA bit.</p>
0 PWMRIEA	<p>PWM Reload Interrupt Enable A — This bit enables the PWMRFA flag to generate CPU interrupt requests.</p> <p>0 PWMRFA CPU interrupt requests disabled 1 PWMRFA CPU interrupt requests enabled</p>

11.3.2.21 PMF Frequency Control A Register (PMFFQCA)

Address: \$0021

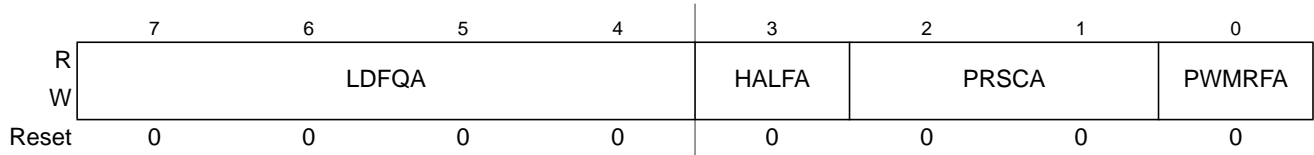

Figure 11-27. PMF Frequency Control A Register (PMFFQCA)

Read and write anytime.

Table 11-26. PMFFQCA Field Descriptions

Field	Description
7–4 LDFQA	<p>Load Frequency A — This field selects the PWM load frequency according to Table 11-27. See Section 11.4.7.2, “Load Frequency” for more details.</p> <p>Note: The LDFQA field takes effect when the current load cycle is complete, regardless of the state of the load okay bit, LDOKA. Reading the LDFQA field reads the buffered value and not necessarily the value currently in effect.</p>
3 HALFA	<p>Half Cycle Reload A — This bit enables half-cycle reloads in center-aligned PWM mode. This bit has no effect on edge-aligned PWMs.</p> <p>0 Half-cycle reloads disabled 1 Half-cycle reloads enabled</p>
2–1 PRSCA	<p>Prescaler A — This buffered field selects the PWM clock frequency illustrated in Table 11-28.</p> <p>Note: Reading the PRSCA field reads the buffered value and not necessarily the value currently in effect. The PRSCA field takes effect at the beginning of the next PWM cycle and only when the load okay bit, LDOKA, is set.</p>
0 PWMRFA	<p>PWM Reload Flag A — This flag is set at the beginning of every reload cycle regardless of the state of the LDOKA bit. Clear PWMRFA by reading PMFFQCA with PWMRFA set and then writing a logic one to the PWMRFA bit. If another reload occurs before the clearing sequence is complete, writing logic one to PWMRFA has no effect.</p> <p>0 No new reload cycle since last PWMRFA clearing 1 New reload cycle since last PWMRFA clearing</p> <p>Note: Clearing PWMRFA satisfies pending PWMRFA CPU interrupt requests.</p>

Table 11-27. PWM Reload Frequency A

LDFQA	PWM Reload Frequency	LDFQ[3:0]	PWM Reload Frequency
0000	Every PWM opportunity	1000	Every 9 PWM opportunities
0001	Every 2 PWM opportunities	1001	Every 10 PWM opportunities
0010	Every 3 PWM opportunities	1010	Every 11 PWM opportunities
0011	Every 4 PWM opportunities	1011	Every 12 PWM opportunities
0100	Every 5 PWM opportunities	1100	Every 13 PWM opportunities
0101	Every 6 PWM opportunities	1101	Every 14 PWM opportunities
0110	Every 7 PWM opportunities	1110	Every 15 PWM opportunities
0111	Every 8 PWM opportunities	1111	Every 16 PWM opportunities

Table 11-28. PWM Prescaler A

PRSCA	PWM Clock Frequency
00	f_{bus}
01	$f_{bus}/2$
10	$f_{bus}/4$
11	$f_{bus}/8$

11.3.2.22 PMF Counter A Register (PMFCNTA)

Address: \$0022

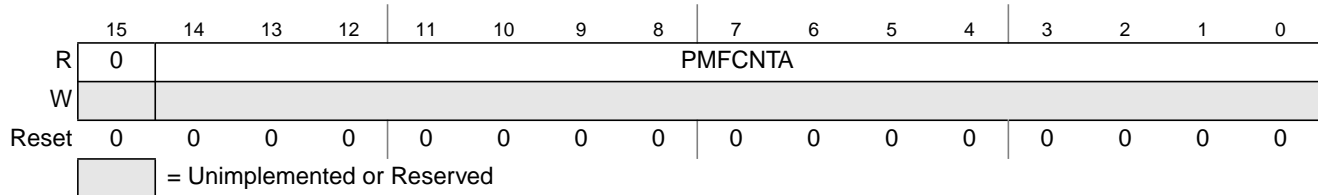

Figure 11-28. PMF Counter A Register (PMFCNTA)

Read anytime and writes have no effect.

This register displays the state of the 15-bit PWM A counter.

11.3.2.23 PMF Counter Modulo A Register (PMFMODA)

Address: \$0024

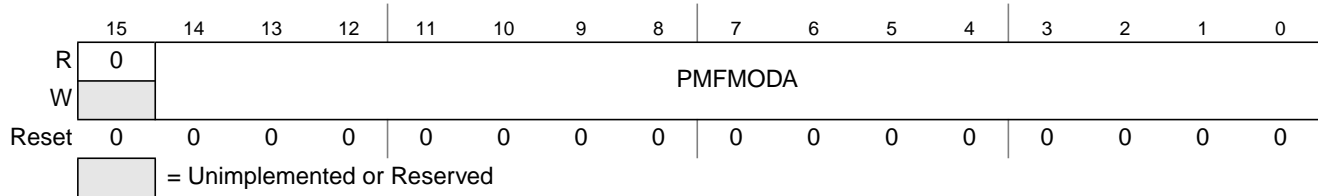

Figure 11-29. PMF Counter Modulo A Register (PMFMODA)

Read and write anytime.

The 15-bit unsigned value written to this register is the PWM period in PWM clock periods. Do not write a modulus value of zero.

NOTE

The PWM counter modulo register is buffered. The value written does not take effect until the LDOKA bit is set and the next PWM load cycle begins. Reading PMFMODA reads the value in the buffer. It is not necessarily the value the PWM generator A is currently using.

11.3.2.24 PMF Deadtime A Register (PMFDTMA)

Address: \$0026

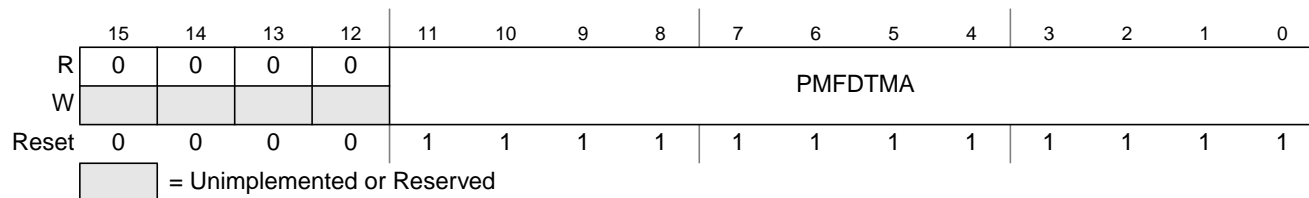

Figure 11-30. PMF Deadtime A Register (PMFDTMA)

Read anytime. This register cannot be modified after the WP bit is set.

The 12-bit value written to this register is the number of PWM clock cycles in complementary channel operation. A reset sets the PWM deadtime register to a default value of 0x0FFF, selecting a deadtime of 4096-PWM clock cycles minus one bus clock cycle.

NOTE

Deadtime is affected by changes to the prescaler value. The deadtime duration is determined as follows: $DT = P \cdot PMFDTMA - 1$, where DT is deadtime, P is the prescaler value, PMFDTMA is the programmed value of dead time. For example: if the prescaler is programmed for a divide-by-two and the PMFDTMA is set to five, then $P = 2$ and the deadtime value is equal to $DT = 2 \cdot 5 - 1 = 9$ IPbus clock cycles. A special case exists when the $P = 1$, then $DT = PMFDTMA$.

11.3.2.25 PMF Enable Control B Register (PMFENCB)

Address: \$0028

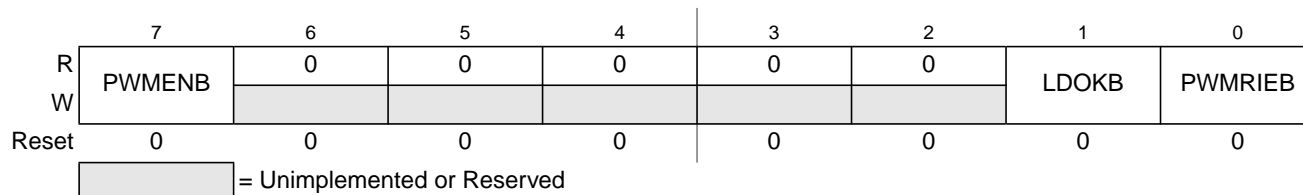

Figure 11-31. PMF Enable Control B Register (PMFENCB)

Read anytime and write only if MTG is set.

Table 11-29. PMFENCB Field Descriptions

Field	Description
7 PWMENB	<p>PWM Generator B Enable — If MTG is clear, this bit reads zero and cannot be written. If MTG is set, this bit when set enables the PWM generator B and the PWM2 and PWM3 pins. When PWMENB is clear, PWM generator B is disabled, and the PWM2 and PWM3 pins are in their inactive states unless the OUTCTL2 and OUTCTL3 bits are set.</p> <p>0 PWM generator B and PWM2–3 pins disabled unless the respective OUTCTL bit is set. 1 PWM generator B and PWM2–3 pins enabled.</p>

Table 11-29. PMFENCB Field Descriptions (continued)

Field	Description
1 LDOKB	<p>Load Okay B — If MTG is clear, this bit reads zero and cannot be written.</p> <p>If MTG is set, this bit loads the PRSCB bits, the PMFMODB register and the PWMVAL2-3 registers into a set of buffers. The buffered prescaler divisor B, PWM counter modulus B value, PWM2–3 pulse widths take effect at the next PWM reload.</p> <p>Set LDOKB by reading it when it is logic zero and then writing a logic one to it. LDOKB is automatically cleared after the new values are loaded, or can be manually cleared before a reload by writing a logic zero to it. Reset clears LDOKB.</p> <p>0 Do not load new modulus B, prescaler B, and PWM2–3 values. 1 Load prescaler B, modulus B, and PWM2–3 values.</p> <p>Note: Do not set PWMENB bit before setting the LDOKB bit and do not clear the LDOKB bit at the same time as setting the PWMENB bit.</p>
0 PWMRIEB	<p>PWM Reload Interrupt Enable B — If MTG is clear, this bit reads zero and cannot be written.</p> <p>If MTG is set, this bit enables the PWMRFB flag to generate CPU interrupt requests.</p> <p>0 PWMRFB CPU interrupt requests disabled 1 PWMRFB CPU interrupt requests enabled</p>

11.3.2.26 PMF Frequency Control B Register (PMFFQCB)

Address: \$0029

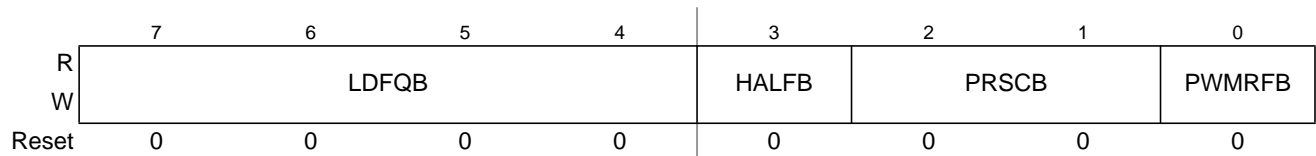
Figure 11-32. PMF Frequency Control B Register (PMFFQCB)

Read anytime and write only if MTG is set.

Table 11-30. PMFFQCB Field Descriptions

Field	Description
7–4 LDFQB	<p>Load Frequency B — This field selects the PWM load frequency according to Table 11-31. See Section 11.4.7.2, “Load Frequency” for more details.</p> <p>Note: The LDFQB field takes effect when the current load cycle is complete, regardless of the state of the load okay bit, LDOKB. Reading the LDFQB field reads the buffered value and not necessarily the value currently in effect.</p>
3 HALFB	<p>Half Cycle Reload B — This bit enables half-cycle reloads in center-aligned PWM mode. This bit has no effect on edge-aligned PWMs.</p> <p>0 Half-cycle reloads disabled 1 Half-cycle reloads enabled</p>
2–1 PRSCB	<p>Prescaler B — This buffered field selects the PWM clock frequency illustrated in Table 11-32.</p> <p>Note: Reading the PRSCB field reads the buffered value and not necessarily the value currently in effect. The PRSCB field takes effect at the beginning of the next PWM cycle and only when the load okay bit, LDOKB, is set.</p>

Table 11-30. PMFFQCB Field Descriptions (continued)

Field	Description
0 PWMRFB	<p>PWM Reload Flag B — This flag is set at the beginning of every reload cycle regardless of the state of the LDOKB bit. Clear PWMRFB by reading PMFFQCB with PWMRFB set and then writing a logic one to the PWMRFB bit. If another reload occurs before the clearing sequence is complete, writing logic one to PWMRFB has no effect.</p> <p>0 No new reload cycle since last PWMRFB clearing 1 New reload cycle since last PWMRFB clearing</p> <p>Note: Clearing PWMRFB satisfies pending PWMRFB CPU interrupt requests.</p>

Table 11-31. PWM Reload Frequency B

LDFQB	PWM Reload Frequency	LDFQ[3:0]	PWM Reload Frequency
0000	Every PWM opportunity	1000	Every 9 PWM opportunities
0001	Every 2 PWM opportunities	1001	Every 10 PWM opportunities
0010	Every 3 PWM opportunities	1010	Every 11 PWM opportunities
0011	Every 4 PWM opportunities	1011	Every 12 PWM opportunities
0100	Every 5 PWM opportunities	1100	Every 13 PWM opportunities
0101	Every 6 PWM opportunities	1101	Every 14 PWM opportunities
0110	Every 7 PWM opportunities	1110	Every 15 PWM opportunities
0111	Every 8 PWM opportunities	1111	Every 16 PWM opportunities

Table 11-32. PWM Prescaler B

PRSCB	PWM Clock Frequency
00	f_{bus}
01	$f_{bus}/2$
10	$f_{bus}/4$
11	$f_{bus}/8$

11.3.2.27 PMF Counter B Register (PMFCNTB)

Address: \$002A

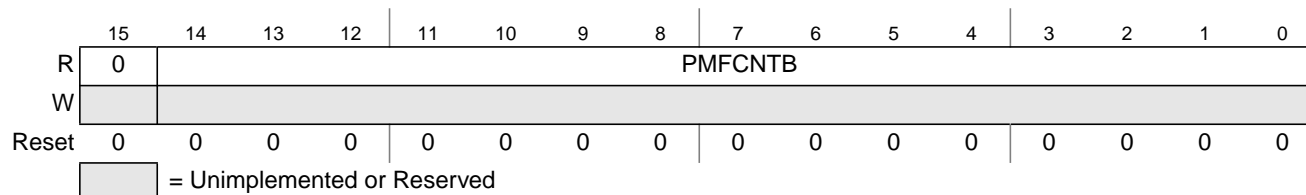

Figure 11-33. PMF Counter B Register (PMFCNTB)

Read anytime and writes have no effect.

This register displays the state of the 15-bit PWM B counter.

11.3.2.28 PMF Counter Modulo B Register (PMFMODB)

Address: \$002C

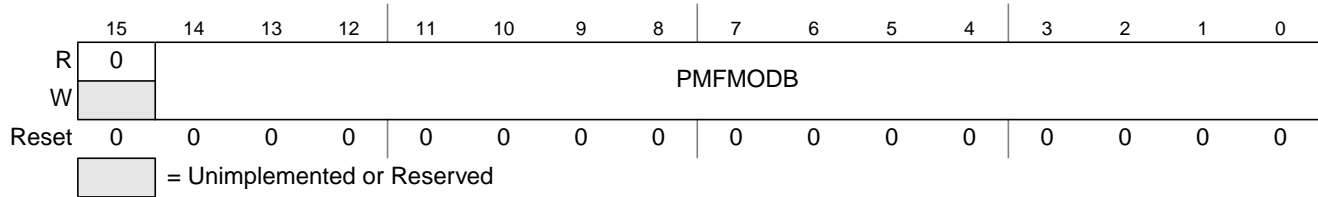
Figure 11-34. PMF Counter Modulo B Register (PMFMODB)

Read anytime and write only if MTG is set.

The 15-bit unsigned value written to this register is the PWM period in PWM clock periods. Do not write a modulus value of zero.

NOTE

The PWM counter modulo register is buffered. The value written does not take effect until the LDOKB bit is set and the next PWM load cycle begins. Reading PMFMODB reads the value in the buffer. It is not necessarily the value the PWM generator B is currently using.

11.3.2.29 PMF Deadtime B Register (PMFDTMB)

Address: \$002E

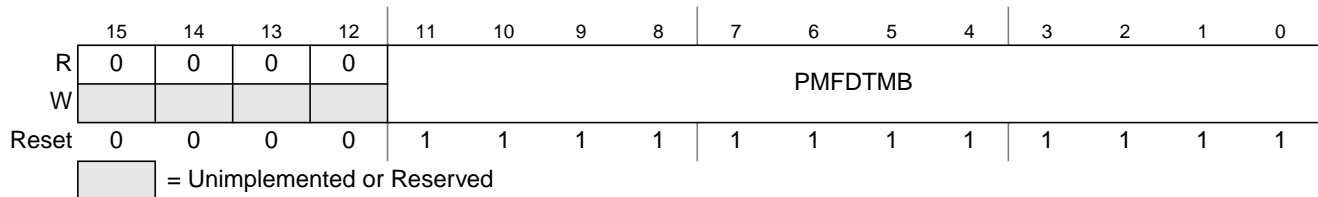
Figure 11-35. PMF Deadtime B Register (PMFDTMB)

Read anytime and write only if MTG is set. This register cannot be modified after the WP bit is set.

The 12-bit value written to this register is the number of PWM clock cycles in complementary channel operation. A reset sets the PWM deadtime register to a default value of 0x0FFF, selecting a deadtime of 4096-PWM clock cycles minus one bus clock cycle.

NOTE

Deadtime is affected by changes to the prescaler value. The deadtime duration is determined as follows: $DT = P \cdot PMFDTMB - 1$, where DT is deadtime, P is the prescaler value, PMFDTMB is the programmed value of dead time. For example: if the prescaler is programmed for a divide-by-two and the PMFDTMB is set to five, then $P = 2$ and the deadtime value is equal to $DT = 2 \cdot 5 - 1 = 9$ IPbus clock cycles. A special case exists when the $P = 1$, then $DT = PMFDTMB$.

11.3.2.30 PMF Enable Control C Register (PMFENCC)

Address: \$0030

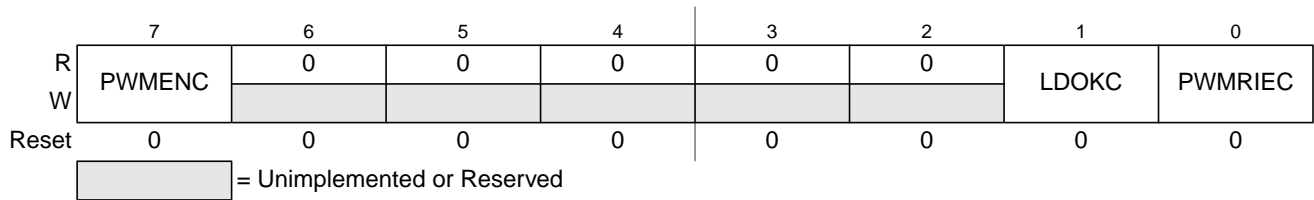

Figure 11-36. PMF Enable Control C Register (PMFENCC)

Read anytime and write only if MTG is set.

Table 11-33. PMFENCC Field Descriptions

Field	Description
7 PWMENC	<p>PWM Generator C Enable — If MTG is clear, this bit reads zero and cannot be written.</p> <p>If MTG is set, this bit when set enables the PWM generator C and the PWM4 and PWM5 pins. When PWMENC is clear, PWM generator C is disabled, and the PWM4 and PWM5 pins are in their inactive states unless the OUTCTL4 and OUTCTL5 bits are set.</p> <p>0 PWM generator C and PWM4–5 pins disabled unless the respective OUTCTL bit is set. 1 PWM generator C and PWM4–5 pins enabled.</p>
1 LDOKC	<p>Load Okay C — If MTG is clear, this bit reads zero and can not be written.</p> <p>If MTG is set, this bit loads the PRSCC bits, the PMFMODEC register and the PWMVAL4–5 registers into a set of buffers. The buffered prescaler divisor C, PWM counter modulus C value, PWM4–5 pulse widths take effect at the next PWM reload.</p> <p>Set LDOKC by reading it when it is logic zero and then writing a logic one to it. LDOKC is automatically cleared after the new values are loaded, or can be manually cleared before a reload by writing a logic zero to it. Reset clears LDOKC.</p> <p>0 Do not load new modulus C, prescaler C, and PWM4–5 values. 1 Load prescaler C, modulus C, and PWM4–5 values.</p> <p>Note: Do not set PWMENC bit before setting the LDOKC bit and do not clear the LDOKC bit at the same time as setting the PWMENC bit.</p>
0 PWMRIEC	<p>PWM Reload Interrupt Enable C — If MTG is clear, this bit reads zero and cannot be written.</p> <p>If MTG is set, this bit enables the PWMRFC flag to generate CPU interrupt requests.</p> <p>0 PWMRFC CPU interrupt requests disabled 1 PWMRFC CPU interrupt requests enabled</p>

11.3.2.31 PMF Frequency Control C Register (PMFFQCC)

Address: \$0031

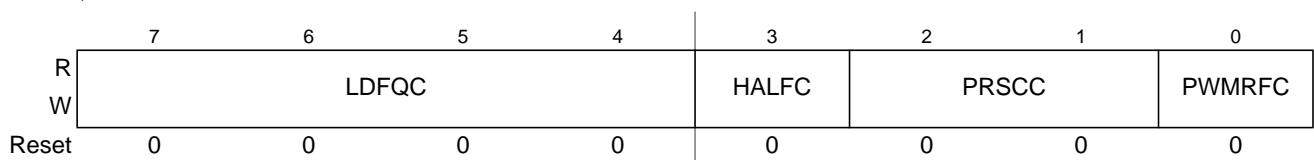

Figure 11-37. PMF Frequency Control C Register (PMFFQCC)

Read anytime and write only if MTG is set.

Table 11-34. PMFFQCC Field Descriptions

Field	Description
7–4 LDFQC	<p>Load Frequency C — This field selects the PWM load frequency according to Table 11-35. See Section 11.4.7.2, “Load Frequency” for more details.</p> <p>Note: The LDFQC field takes effect when the current load cycle is complete, regardless of the state of the load okay bit, LDOKC. Reading the LDFQC field reads the buffered value and not necessarily the value currently in effect.</p>
3 HALFC	<p>Half Cycle Reload C — This bit enables half-cycle reloads in center-aligned PWM mode. This bit has no effect on edge-aligned PWMs.</p> <p>0 Half-cycle reloads disabled 1 Half-cycle reloads enabled</p>
2–1 PRSCC	<p>Prescaler C — This buffered field selects the PWM clock frequency illustrated in Table 11-36.</p> <p>Note: Reading the PRSCC field reads the buffered value and not necessarily the value currently in effect. The PRSCC field takes effect at the beginning of the next PWM cycle and only when the load okay bit, LDOKC, is set.</p>
0 PWMRFC	<p>PWM Reload Flag C — This flag is set at the beginning of every reload cycle regardless of the state of the LDOKC bit. Clear PWMRFC by reading PMFFQCC with PWMRFC set and then writing a logic one to the PWMRFC bit. If another reload occurs before the clearing sequence is complete, writing logic one to PWMRFC has no effect.</p> <p>0 No new reload cycle since last PWMRFC clearing 1 New reload cycle since last PWMRFC clearing</p> <p>Note: Clearing PWMRFC satisfies pending PWMRFC CPU interrupt requests.</p>

Table 11-35. PWM Reload Frequency C

LDFQC	PWM Reload Frequency	LDFQ[3:0]	PWM Reload Frequency
0000	Every PWM opportunity	1000	Every 9 PWM opportunities
0001	Every 2 PWM opportunities	1001	Every 10 PWM opportunities
0010	Every 3 PWM opportunities	1010	Every 11 PWM opportunities
0011	Every 4 PWM opportunities	1011	Every 12 PWM opportunities
0100	Every 5 PWM opportunities	1100	Every 13 PWM opportunities
0101	Every 6 PWM opportunities	1101	Every 14 PWM opportunities
0110	Every 7 PWM opportunities	1110	Every 15 PWM opportunities
0111	Every 8 PWM opportunities	1111	Every 16 PWM opportunities

Table 11-36. PWM Prescaler C

PRSCC	PWM Clock Frequency
00	f_{bus}
01	$f_{bus}/2$
10	$f_{bus}/4$
11	$f_{bus}/8$

11.3.2.32 PMF Counter C Register (PMFCNTC)

Address: \$0032

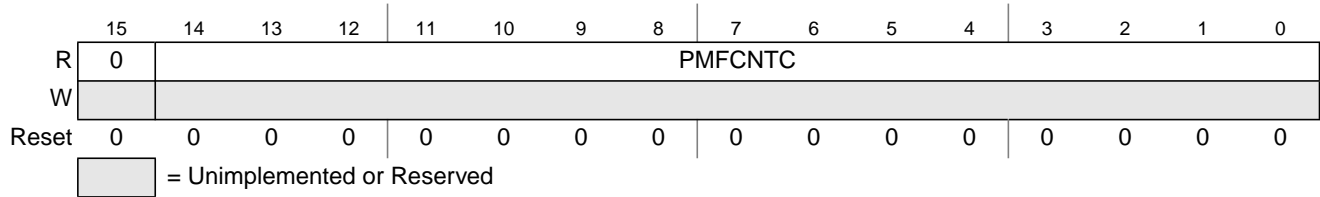

Figure 11-38. PMF Counter C Register (PMFCNTC)

Read anytime and writes have no effect.

This register displays the state of the 15-bit PWM C counter.

11.3.2.33 PMF Counter Modulo C Register (PMFMODC)

Address: \$0034

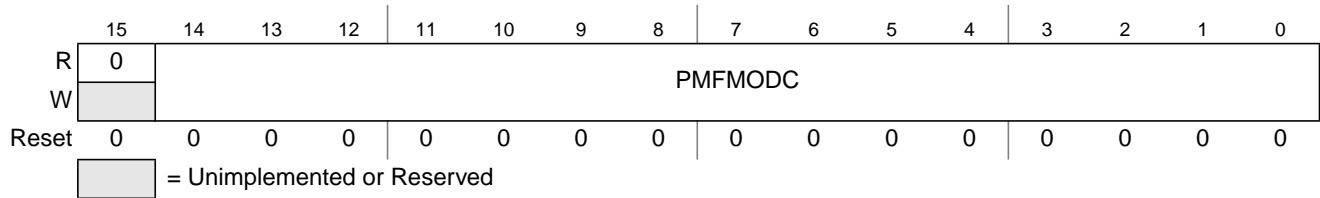

Figure 11-39. PMF Counter Modulo C Register (PMFMODC)

Read anytime and write only if MTG is set.

The 15-bit unsigned value written to this register is the PWM period in PWM clock periods. Do not write a modulus value of zero.

NOTE

The PWM counter modulo register is buffered. The value written does not take effect until the LDOKC bit is set and the next PWM load cycle begins. Reading PMFMODC reads the value in the buffer. It is not necessarily the value the PWM generator A is currently using.

11.3.2.34 PMF Deadtime C Register (PMFDTMC)

Address: \$0036

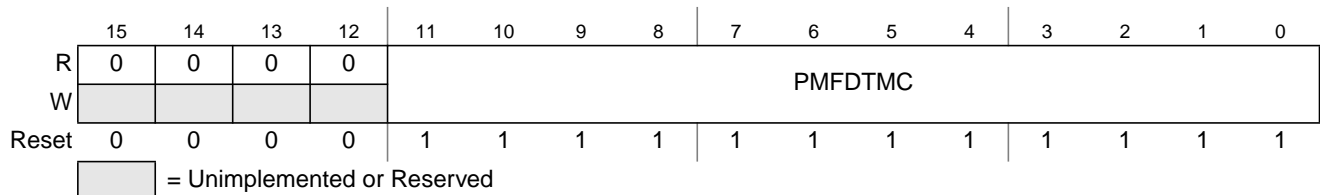

Figure 11-40. PMF Deadtime C Register (PMFDTMC)

Read anytime and write only if MTG is set. This register cannot be modified after the WP bit is set.

The 12-bit value written to this register is the number of PWM clock cycles in complementary channel operation. A reset sets the PWM deadtime register to a default value of 0x0FFF, selecting a deadtime of 4096-PWM clock cycles minus one bus clock cycle.

NOTE

Deadtime is affected by changes to the prescaler value. The deadtime duration is determined as follows: $DT = P \cdot PMFDTMC - 1$, where DT is deadtime, P is the prescaler value, PMFDTMC is the programmed value of dead time. For example: if the prescaler is programmed for a divide-by-two and the PMFDTMC is set to five, then $P = 2$ and the deadtime value is equal to $DT = 2 \cdot 5 - 1 = 9$ IPbus clock cycles. A special case exists when the $P = 1$, then $DT = PMFDTMC$.

11.4 Functional Description

11.4.1 Block Diagram

A block diagram of the PMF is shown in [Figure 11-1](#). The MTG bit allows the use of multiple PWM generators (A, B, and C) or just a single generator (A). PWM0 and PWM1 constitute Pair A, PWM2 and PWM3 constitute Pair B, and PWM4 and PWM5 constitute Pair C.

11.4.2 Prescaler

To permit lower PWM frequencies, the prescaler produces the PWM clock frequency by dividing the bus clock frequency by one, two, four, and eight. Each PWM generator has its own prescaler divisor. Each prescaler is buffered and will not be used by its PWM generator until the corresponding Load OK bit is set and a new PWM reload cycle begins.

11.4.3 PWM Generator

Each PWM generator contains a 15-bit up/down PWM counter producing output signals with software-selectables:

- Alignment — The logic state of each pair EDGE bit determines whether the PWM pair outputs are edge-aligned or center-aligned
- Period — The value written to each pair PWM counter modulo register is used to determine the PWM pair period. The period can also be varied by using the prescaler
- With edge-aligned output, the modulus is the period of the PWM output in clock cycles
- With center-aligned output, the modulus is one-half of the PWM output period in clock cycles
- Pulse width — The number written to the PWM value register determines the pulse width duty cycle of the PWM output in clock cycles
 - With center-aligned output, the pulse width is twice the value written to the PWM value register
 - With edge-aligned output, the pulse width is the value written to the PWM value register

11.4.3.1 Alignment

Each edge-align bit, EDGEx, selects either center-aligned or edge-aligned PWM generator outputs.

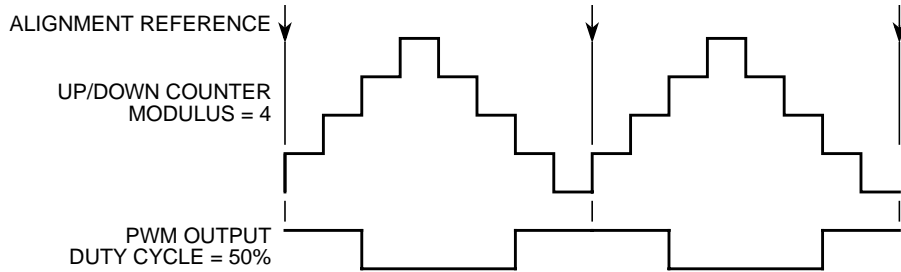

Figure 11-41. Center-Aligned PWM Output

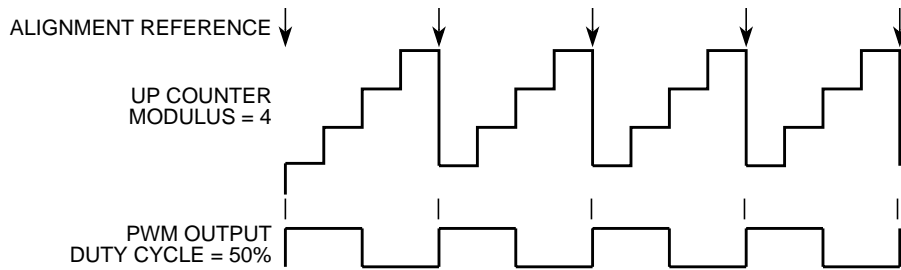

Figure 11-42. Edge-Aligned PWM Output

NOTE

Because of the equals-comparator architecture of this PMF, the modulus equals zero case is considered illegal. Therefore, the modulus register does not return to zero, and a modulus value of zero will result in waveforms inconsistent with the other modulus waveforms. If a modulus of zero is loaded, the counter will continually count down from \$7FFF. This operation will not be tested or guaranteed. Consider it illegal. However, the dead-time constraints and fault conditions will still be guaranteed.

11.4.3.2 Period

A PWM period is determined by the value written to the PWM counter modulo register.

The PWM counter is an up/down counter in a center-aligned operation. In this mode the PWM highest output resolution is two bus clock cycles.

$$\text{PWM period} = (\text{PWM modulus}) \cdot (\text{PWM clock period}) \cdot 2$$

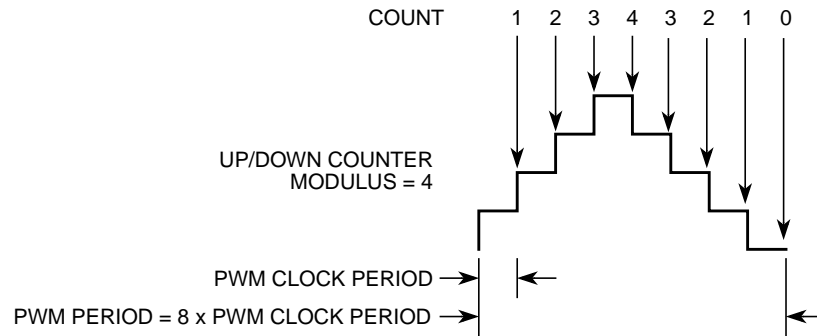

Figure 11-43. Center-Aligned PWM Period

In an edge-aligned operation, the PWM counter is an up counter. The PWM output resolution is one bus clock cycle.

$$\text{PWM period} = \text{PWM modulus} \cdot \text{PWM clock period}$$

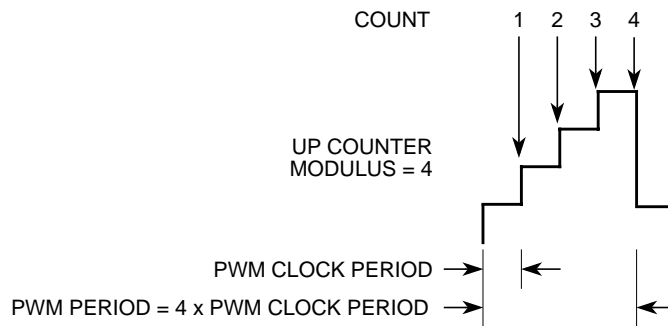

Figure 11-44. Edge-Aligned PWM Period

11.4.3.3 Duty Cycle

The signed 16-bit number written to the PMF value registers is the pulse width in PWM clock periods of the PWM generator output.

$$\text{Duty cycle} = \frac{\text{PMFVAL}}{\text{MODULUS}} \cdot 100$$

NOTE

A PWM value less than or equal to zero deactivates the PWM output for the entire PWM period. A PWM value greater than or equal to the modulus activates the PWM output for the entire PWM period.

Table 11-37. PWM Value and Underflow Conditions

PMFVALx	Condition	PWM Value Used
\$0000–\$7FFF	Normal	Value in registers
\$8000–\$FFFF	Underflow	\$0000

Center-aligned operation is illustrated in [Figure 11-45](#).

$$\text{PWM pulse width} = (\text{PWM value}) \cdot (\text{PWM clock period}) \cdot 2$$

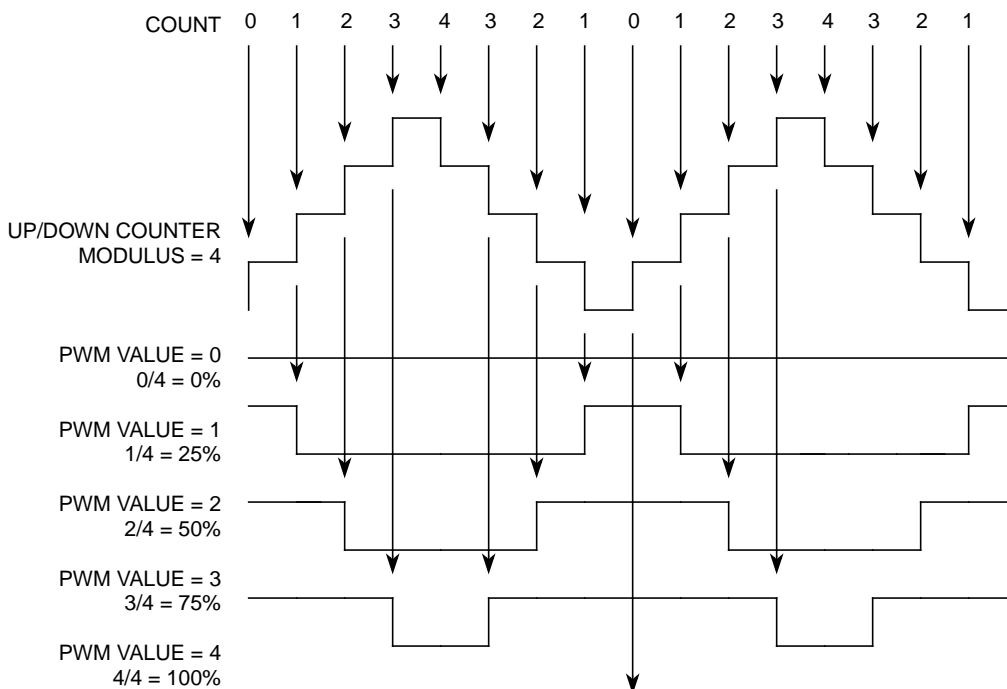

Figure 11-45. Center-Aligned PWM Pulse Width

Edge-aligned operation is illustrated in [Figure 11-46](#).

$$\text{PWM pulse width} = (\text{PWM value}) \cdot (\text{PWM clock period})$$

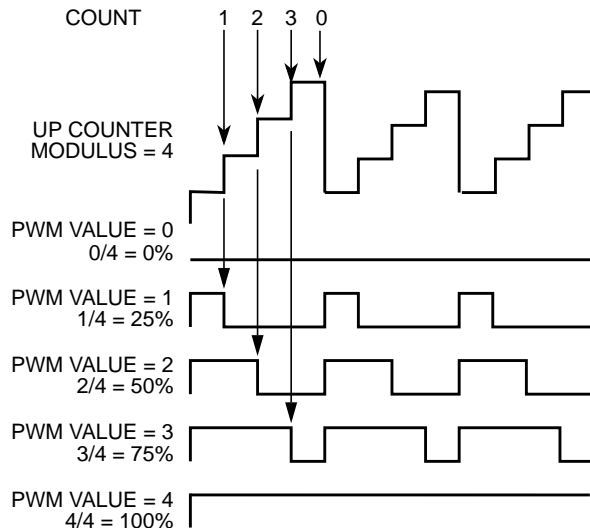

Figure 11-46. Edge-Aligned PWM Pulse Width

11.4.4 Independent or Complementary Channel Operation

Writing a logic one to a INDEPx bit configures a pair of the PWM outputs as two independent PWM channels. Each PWM output has its own PWM value register operating independently of the other channels in independent channel operation.

Writing a logic zero to a INDEPx bit configures the PWM output as a pair of complementary channels. The PWM pins are paired as shown in [Figure 11-47](#) in complementary channel operation.

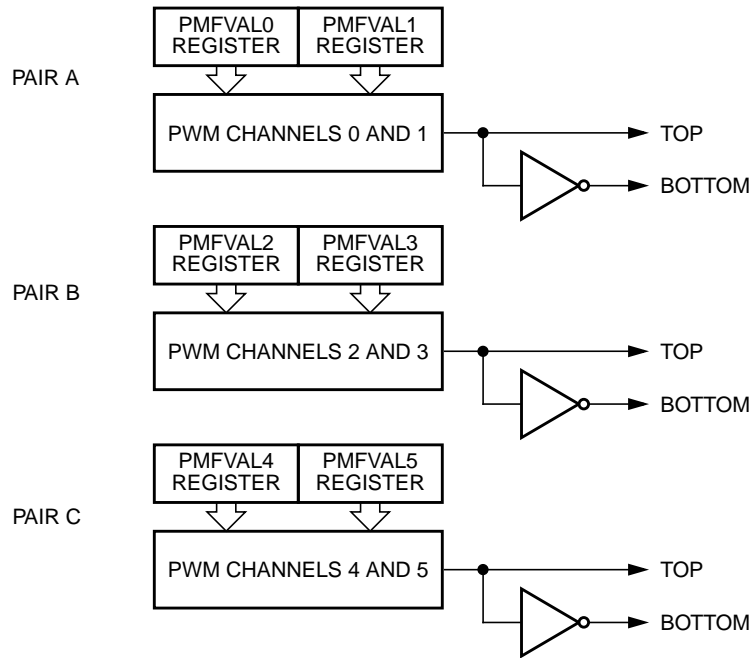

Figure 11-47. Complementary Channel Pairs

The complementary channel operation is for driving top and bottom transistors in a motor drive circuit, such as the one in [Figure 11-48](#).

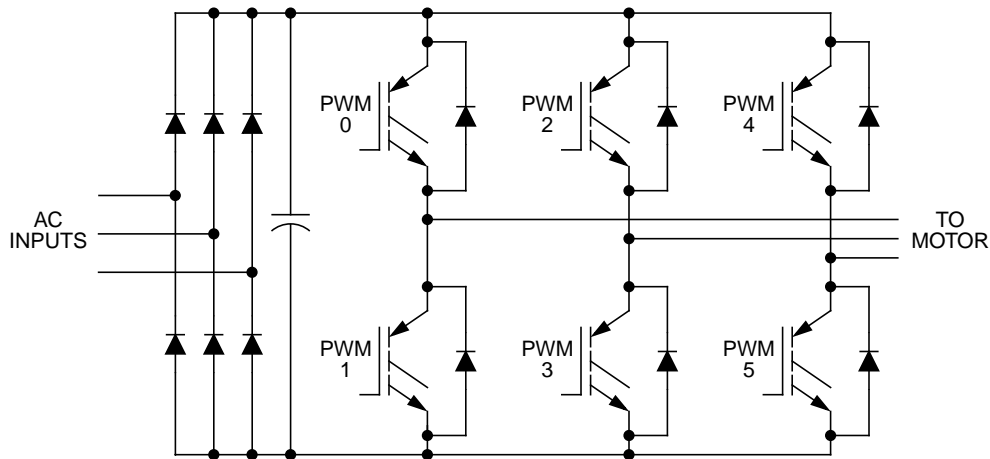

Figure 11-48. Typical 3 Phase AC Motor Drive

In complementary channel operation, there are three additional features:

- Deadtime insertion
- Separate top and bottom pulse width correction for distortions are caused by deadtime inserted and the motor drive characteristics
- Separate top and bottom output polarity control

- Swap functionality

11.4.5 Deadtime Generators

While in the complementary mode, each PWM pair can be used to drive top/bottom transistors, as shown in Figure 11-49. Ideally, the PWM pairs are an inversion of each other. When the top PWM channel is active, the bottom PWM channel is inactive, and vice versa.

NOTE

To avoid a short-circuit on the DC bus and endangering the transistor, there must be no overlap of conducting intervals between top and bottom transistor. But the transistor’s characteristics make its switching-off time longer than switching-on time. To avoid the conducting overlap of top and bottom transistors, deadtime needs to be inserted in the switching period.

Deadtime generators automatically insert software-selectable activation delays into each pair of PWM outputs. The deadtime register (PMFDTMx) specifies the number of PWM clock cycles to use for deadtime delay. Every time the deadtime generator input changes state, deadtime is inserted. Deadtime forces both PWM outputs in the pair to the inactive state.

A method of correcting this, adding to or subtracting from the PWM value used, is discussed next.

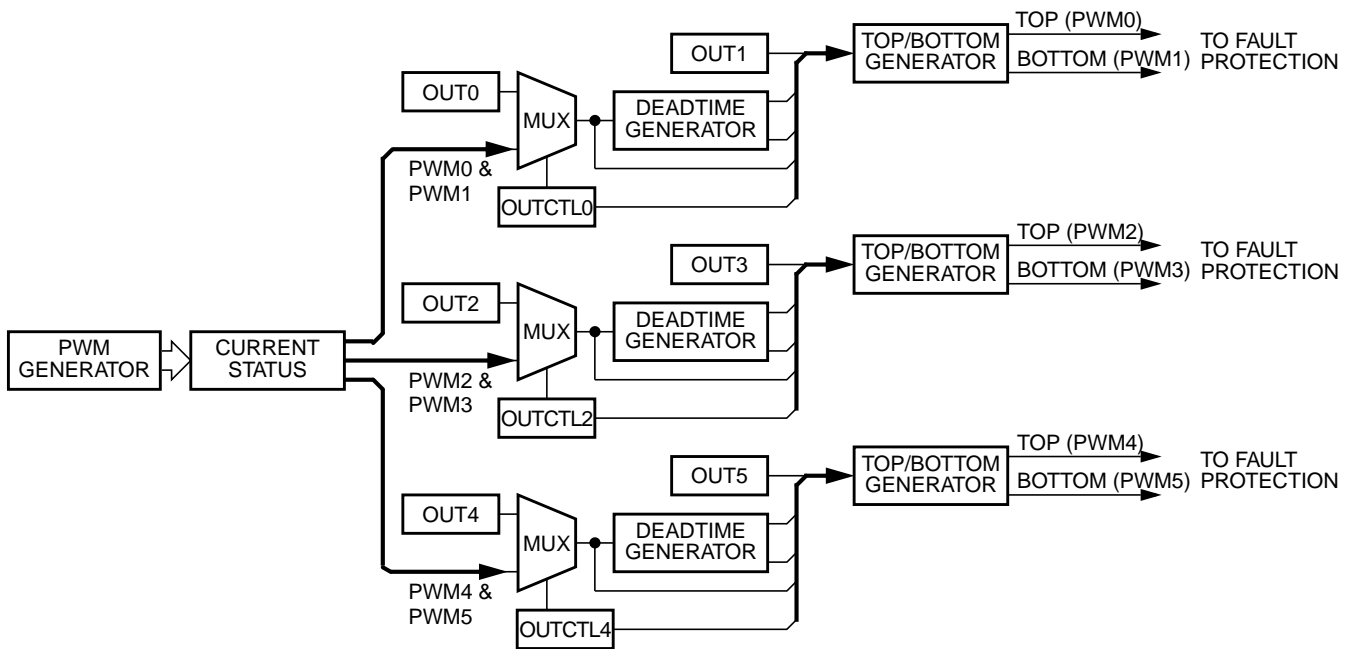

Figure 11-49. Deadtime Generators

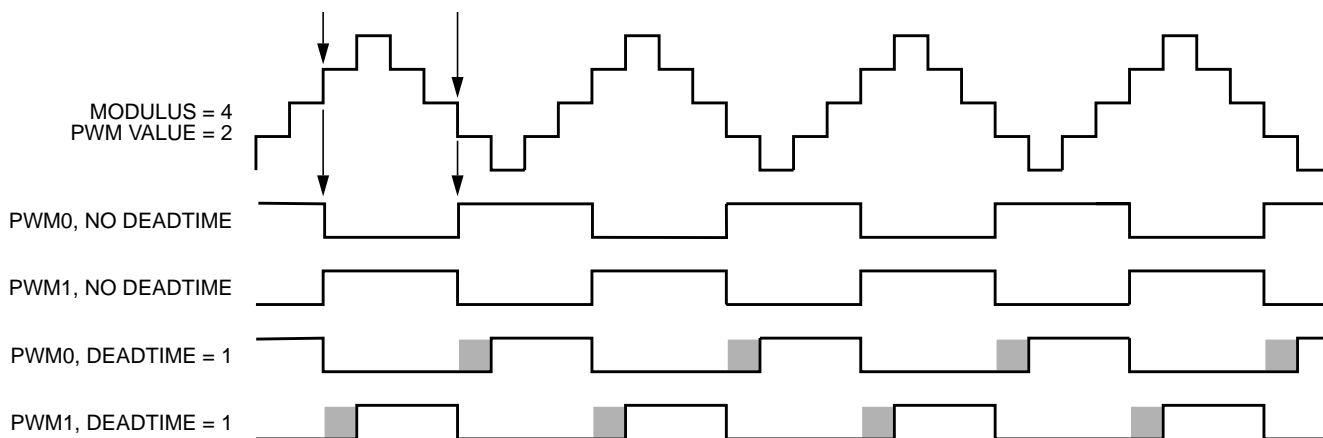

Figure 11-50. Deadtime Insertion, Center Alignment

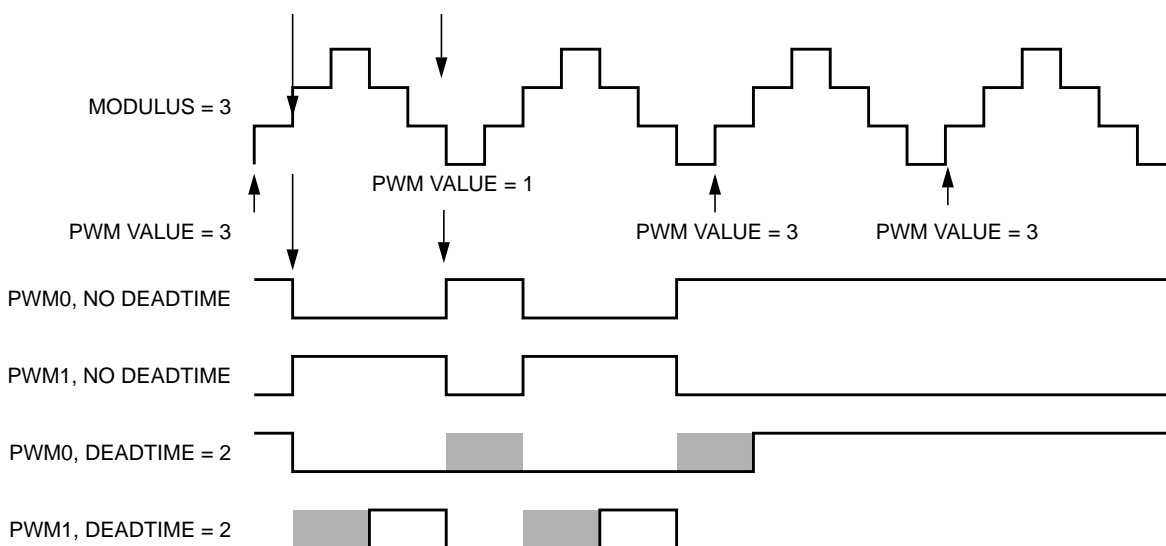

Figure 11-51. Deadtime at Duty Cycle Boundaries

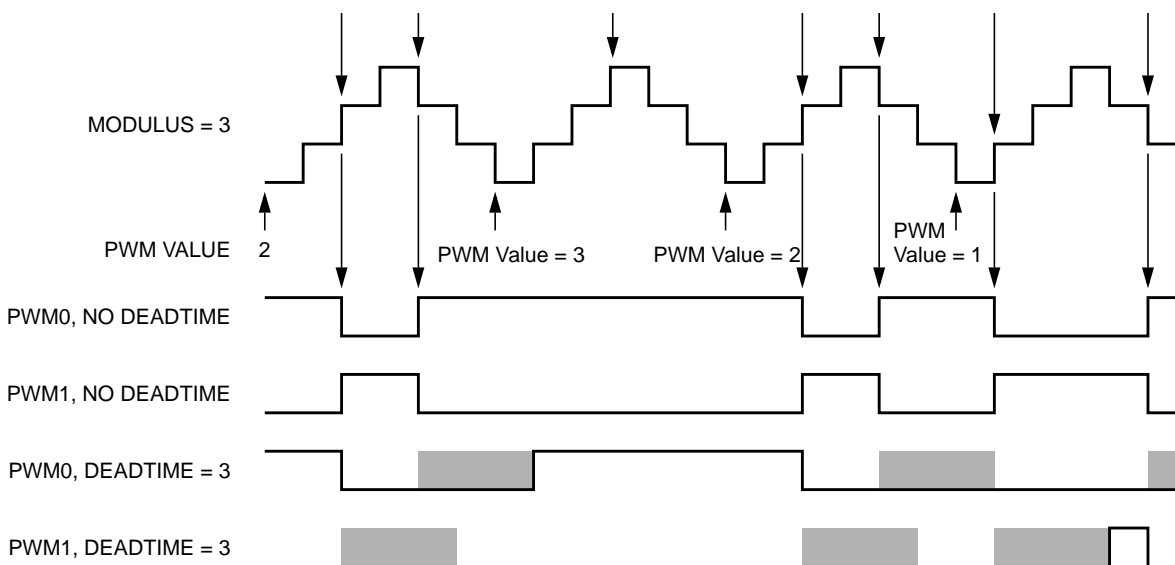

Figure 11-52. Deadtime and Small Pulse Widths

NOTE

The waveform at the pad is delayed by two bus clock cycles for deadtime insertion.

11.4.5.1 Top/Bottom Correction

In complementary mode, either the top or the bottom transistor controls the output voltage. However, deadtime has to be inserted to avoid overlap of conducting interval between the top and bottom transistor. Both transistors in complementary mode are off during deadtime, allowing the output voltage to be determined by the current status of load and introduce distortion in the output voltage. See [Figure 11-53](#). On AC induction motors running open-loop, the distortion typically manifests itself as poor low-speed performance, such as torque ripple and rough operation.

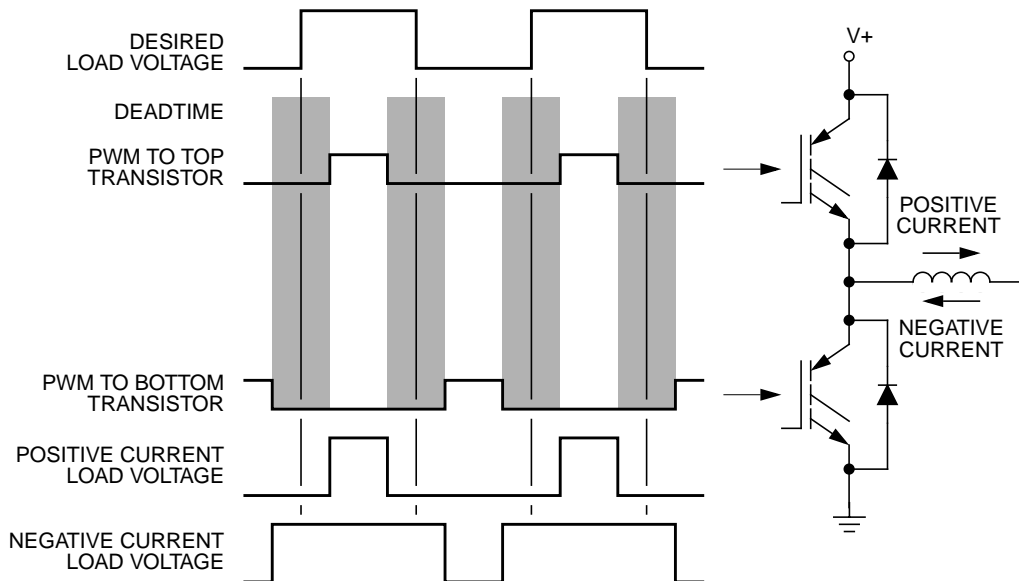

Figure 11-53. Deadtime Distortion

During deadtime, load inductance distorts output voltage by keeping current flowing through the diodes. This deadtime current flow creates a load voltage that varies with current direction. With a positive current flow, the load voltage during deadtime is equal to the bottom supply, putting the top transistor in control. With a negative current flow, the load voltage during deadtime is equal to the top supply putting the bottom transistor in control.

Remembering that the original PWM pulse widths were shortened by deadtime insertion, the averaged sinusoidal output will be less than desired value. However, when deadtime is inserted, it creates a distortion in motor current waveform. This distortion is aggravated by dissimilar turn-on and turn-off delays of each of the transistors. By giving the PWM module information on which transistor is controlling at a given time this distortion can be corrected.

For a typical circuit in complementary channel operation, only one of the transistors will be effective in controlling the output voltage at any given time. This depends on the direction of the motor current for that pair. See [Figure 11-53](#). To correct distortion one of two different factors must be added to the desired PWM value, depending on whether the top or bottom transistor is controlling the output voltage. Therefore, the

software is responsible for calculating both compensated PWM values prior to placing them in an odd-numbered/even numbered PWM register pair. Either the odd or the even PMFVAL register controls the pulse width at any given time. For a given PWM pair, whether the odd or even PMFVAL register is active depends on either:

- The state of the current status pin, \overline{IS}_x , for that driver
- The state of the odd/even correction bit, IPOLx, for that driver
- To correct deadtime distortion, software can decrease or increase the value in the appropriate PMFVAL register.
- In edge-aligned operation, decreasing or increasing the PWM value by a correction value equal to the deadtime typically compensates for deadtime distortion.
- In center-aligned operation, decreasing or increasing the PWM value by a correction value equal to one-half the deadtime typically compensates for deadtime distortion.
- In the complementary channel operation, ISENS selects one of three correction methods:
- Manual correction
- Automatic current status correction during deadtime
- Automatic current status correction when the PWM counter value equals the value in the PWM counter modulus registers

Table 11-38. Correction Method Selection

ISENS	Correction Method
00	No correction ⁽¹⁾
01	Manual correction
10	Current status sample correction on pins \overline{IS}_0 , \overline{IS}_1 , and \overline{IS}_2 during deadtime ⁽²⁾
11	Current status sample on pins \overline{IS}_0 , \overline{IS}_1 , and \overline{IS}_2 ⁽³⁾ At the half cycle in center-aligned operation At the end of the cycle in edge-aligned operation

1. The current status pins can be used as general purpose input/output ports.
2. The polarity of the \overline{IS}_x pin is latched when both the top and bottom PWMs are off. At the 0% and 100% duty cycle boundaries, there is no deadtime, so no new current value is sensed.
3. Current is sensed even with 0% or 100% duty cycle.

NOTE

Assume the user will provide current status sensing circuitry causing the voltage at the corresponding input pin to be low for positive current and high for negative current. In addition, it assumes the top PWMs are PWM 0, 2, and 4 while the bottom PWMS are PWM 1, 3, and 5.

11.4.5.2 Manual Correction

The IPOLx bits select either the odd or the even PWM value registers to use in the next PWM cycle.

Table 11-39. Top/Bottom Manual Correction

Bit	Logic state	Output Control
IPOLA	0	PMFVAL0 controls PWM0/PWM1 pair
	1	PMFVAL1 controls PWM0/PWM1 pair
IPOLB	0	PMFVAL2 controls PWM2/PWM3 pair
	1	PMFVAL3 controls PWM2/PWM3 pair
IPOLC	0	PMFVAL4 controls PWM4/PWM5 pair
	1	PMFVAL5 controls PWM4/PWM5 pair

NOTE

IPOLx bits are buffered so only one PWM register is used per PWM cycle. If an IPOLx bit changes during a PWM period, the new value does not take effect until the next PWM period.

IPOLx bits take effect at the end of each PWM cycle regardless of the state of the load okay bit, LDOK.

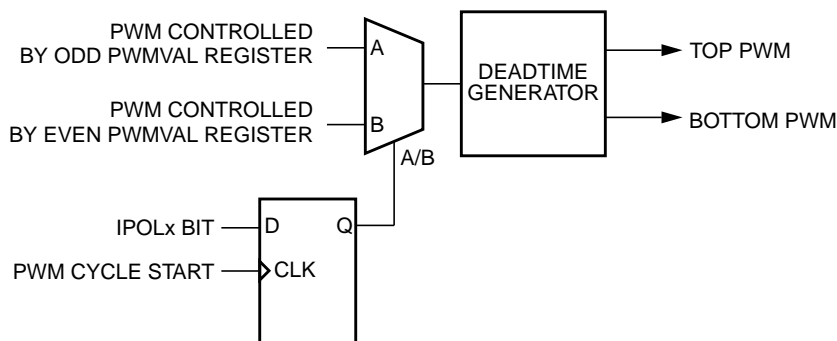

Figure 11-54. Internal Correction Logic when ISENS = 01

To detect the current status, the voltage on each \overline{ISx} pin is sampled twice in a PWM period, at the end of each deadtime. The value is stored in the DTx bits in the PMF Deadtime Sample register (PMFDTMS). The DTx bits are a timing marker especially indicating when to toggle between PWM value registers. Software can then set the IPOLx bit to toggle PMFVAL registers according to DTx values.

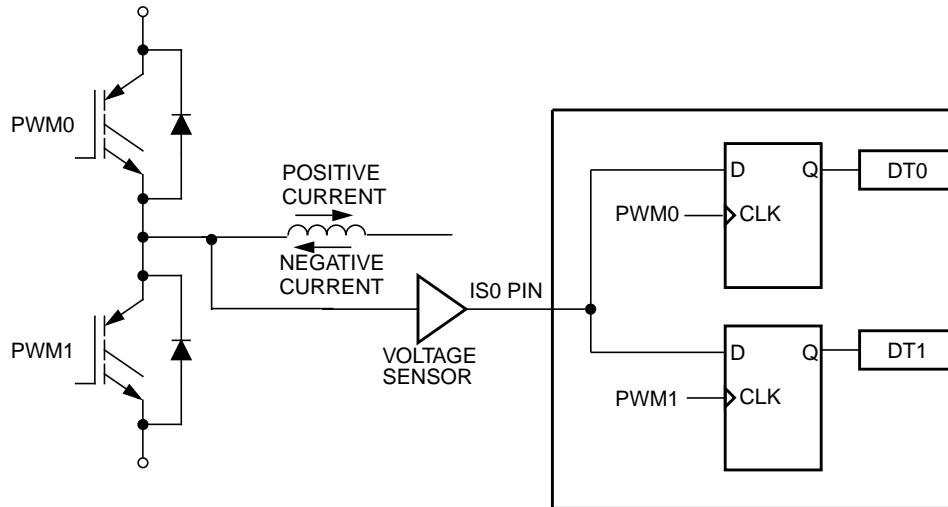

Figure 11-55. Current Status Sense Scheme for Deadtime Correction

If both D flip-flops latch low, $DT0 = 0$, $DT1 = 0$, during deadtime periods if current is large and flowing out of the complementary circuit. See [Figure 11-55](#). If both D flip-flops latch the high, $DT0 = 1$, $DT1 = 1$, during deadtime periods if current is also large and flowing into the complementary circuit. However, under low-current, the output voltage of the complementary circuit during deadtime is somewhere between the high and low levels. The current cannot free-wheel throughout the opposition anti-body diode, regardless of polarity, giving additional distortion when the current crosses zero. Sampled results will be $DT0 = 0$ and $DT1 = 1$. Thus, the best time to change one PWM value register to another is just before the current zero crossing.

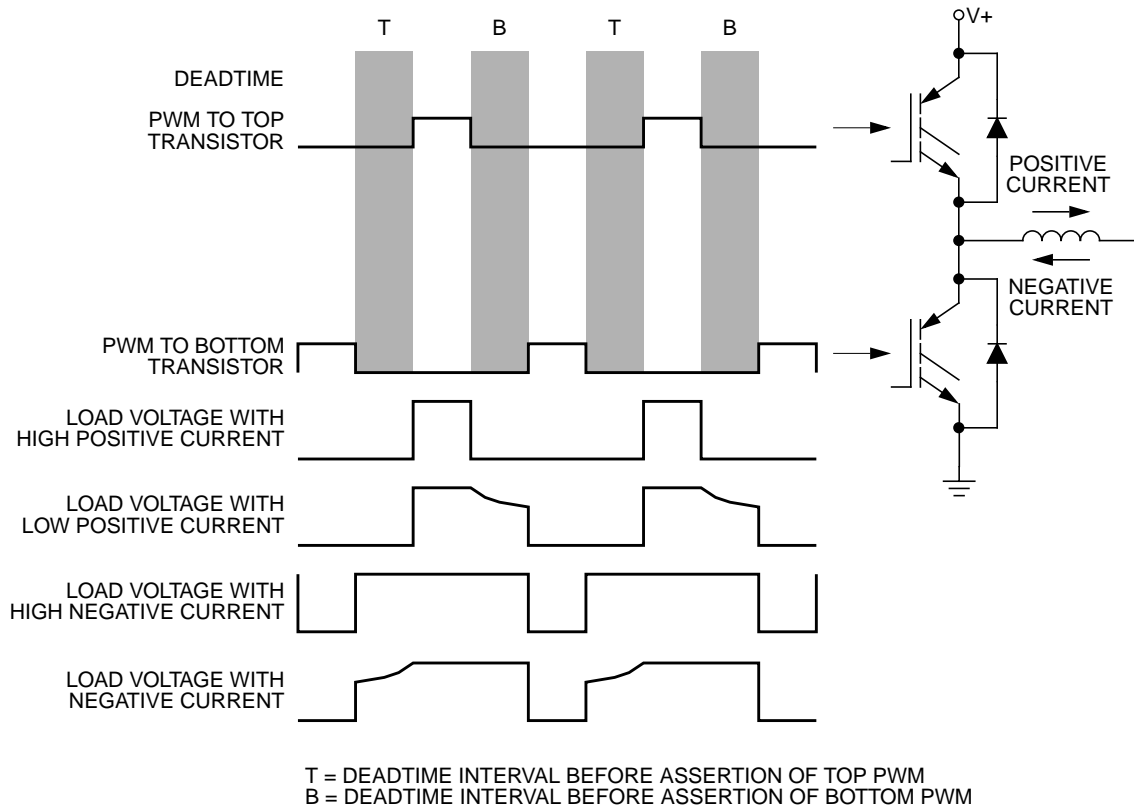

Figure 11-56. Output Voltage Waveforms

11.4.5.3 Current-Sensing Correction

A current sense pin, \overline{ISx} , for a PWM pair selects either the odd or the even PWM value registers to use in the next PWM cycle. The selection is based on user-provided current sense circuitry driving the \overline{ISx} pin high for negative current and low for positive current.

Table 11-40. Top/Bottom Current Sense Correction

Pin	Logic State	Output Control
IS0	0	PMFVAL0 controls PWM0/PWM1 pair
	1	PMFVAL1 controls PWM0/PWM1 pair
IS1	0	PMFVAL2 controls PWM2/PWM3 pair
	1	PMFVAL3 controls PWM2/PWM3 pair
IS2	0	PMFVAL4 controls PWM4/PWM5 pair
	1	PMFVAL5 controls PWM4/PWM5 pair

Previously shown, the current direction can be determined by the output voltage during deadtime. Thus, a simple external voltage sensor can be used when current status is completed during deadtime, $ISENS = 10$. Deadtime does not exist at the 100 percent and zero percent duty cycle boundaries. Therefore, the second automatic mode must be used for correction, $ISENS = 11$, where current status is sampled at the half cycle in center-aligned operation and at the end of cycle in edge-aligned operation. Using this mode requires external circuitry. It actually senses current direction.

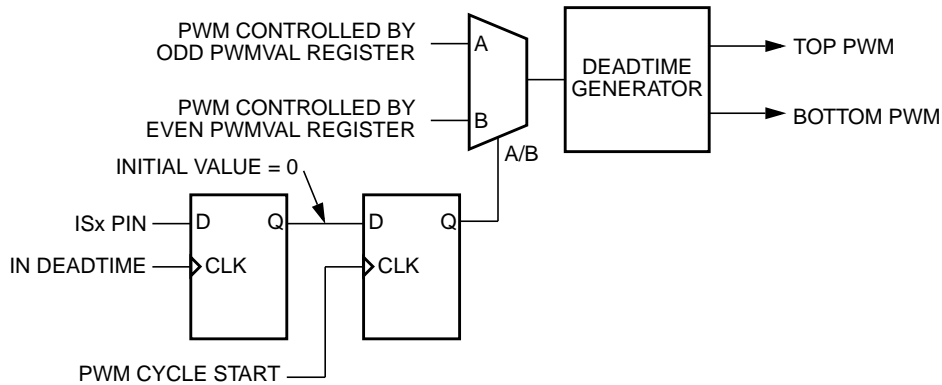

Figure 11-57. Internal Correction Logic when ISENS = 10

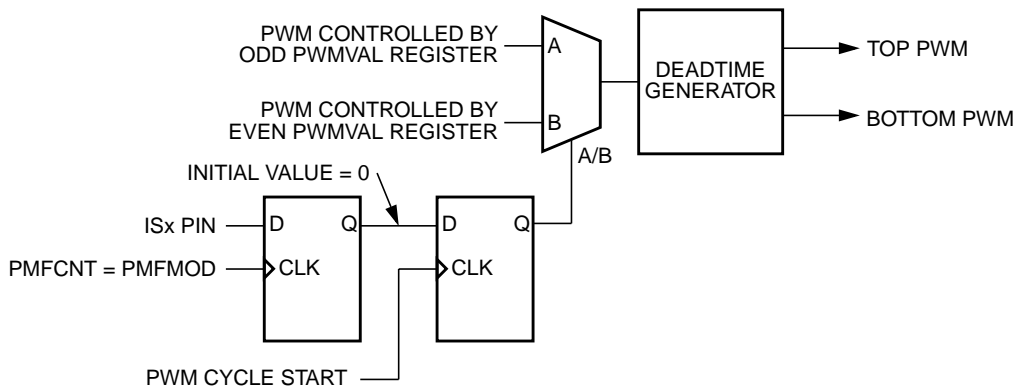

Figure 11-58. Internal Correction Logic when ISENS = 11

NOTE

Values latched on the \overline{ISx} pins are buffered so only one PWM register is used per PWM cycle. If a current status changes during a PWM period, the new value does not take effect until the next PWM period.

When initially enabled by setting the PWMEN bit, no current status has previously been sampled. PWM value registers one, three, and five initially control the three PWM pairs when configured for current status correction.

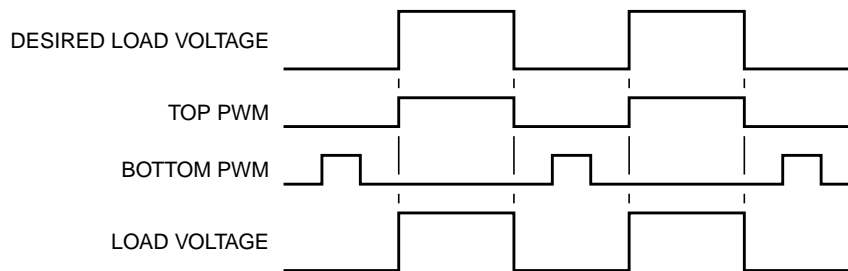

Figure 11-59. Correction with Positive Current

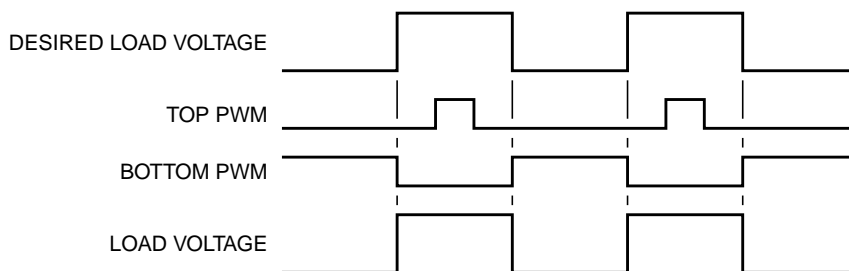

Figure 11-60. Correction with Negative Current

11.4.5.4 Output Polarity

Output polarity of the PWMs is determined by two options: TOPNEG and BOTNEG. The top polarity option, TOPNEG, controls the polarity of PWM0, PWM2 and PWM4. The bottom polarity option, BOTNEG, controls the polarity of PWM1, PWM3 and PWM5. *Positive* polarity means when the PWM is active its output is high. Conversely, *negative* polarity means when the PWM is active its output is low.

The TOPNEG and BOTNEG are in the configure register. TOPNEG is the output of PWM0, PWM2 and PWM4. They are active low. If TOPNEG is set, PWM0, PWM2, and PWM4 outputs become *active-low*. When BOTNEG is set, PWM1, PWM3, and PWM5 outputs are *active-low*. When these bits are clear, their respective PWM pins are *active-high*. See Figure 11-59 and Figure 11-60.

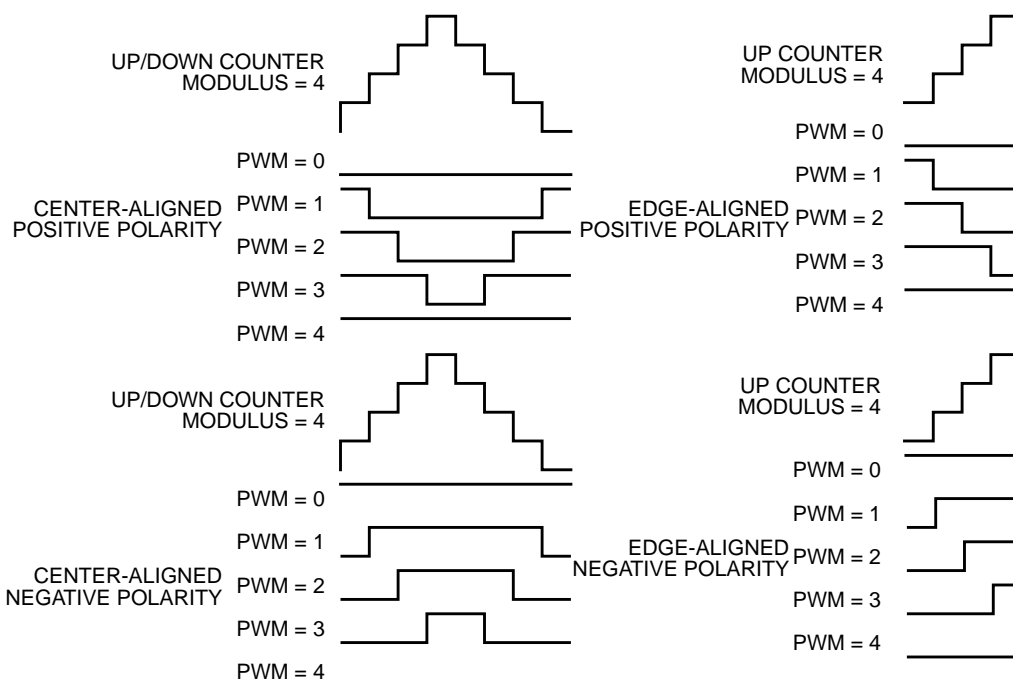

Figure 11-61. PWM Polarity

11.4.6 Software Output Control

Setting output control enable bit, OUTCTLx, enables software to drive the PWM outputs rather than the PWM generator. In an independent mode, with OUTCTLx = 1, the output bit OUTx, controls the PWMx

channel. In a complementary channel operation the even OUTCTL bit is used to enable software output control for the pair. But the OUTCTL bits must be switched in pairs for proper operation. The OUTCTLx and OUTx bits are in the PWM output control register.

NOTE

During software output control, TOPNEG and BOTNEG still control output polarity. It will take up to 3 clock cycles to see the effect of output control on the PWM output pins.

In independent PWM operation, setting or clearing the OUTx bit activates or deactivates the PWMx output.

In complementary channel operation, the even-numbered OUTx bits replace the PWM generator outputs as inputs to the deadtime generators. Complementary channel pairs still cannot be active simultaneously, and the deadtime generators continue to insert deadtime in both channels of that pair, whenever an even OUTx bit toggles. Even OUTx bits control the top PWM signals while the odd OUTx bits control the bottom PWM signals with respect to the even OUTx bits. Setting the odd OUTx bit makes its corresponding PWMx the complement of its even pair, while clearing the odd OUTx bit deactivates the odd PWMx.

Setting the OUTCTLx bits do not disable the PWM generators and current status sensing circuitry. They continue to run, but no longer control the output pins. When the OUTCTLx bits are cleared, the outputs of the PWM generator become the inputs to the deadtime generators at the beginning of the next PWM cycle. Software can drive the PWM outputs even when PWM enable bit (PWMEN) is set to zero.

NOTE

Avoid an unexpected deadtime insertion by clearing the OUTx bits before setting and after clearing the OUTCTLx bits.

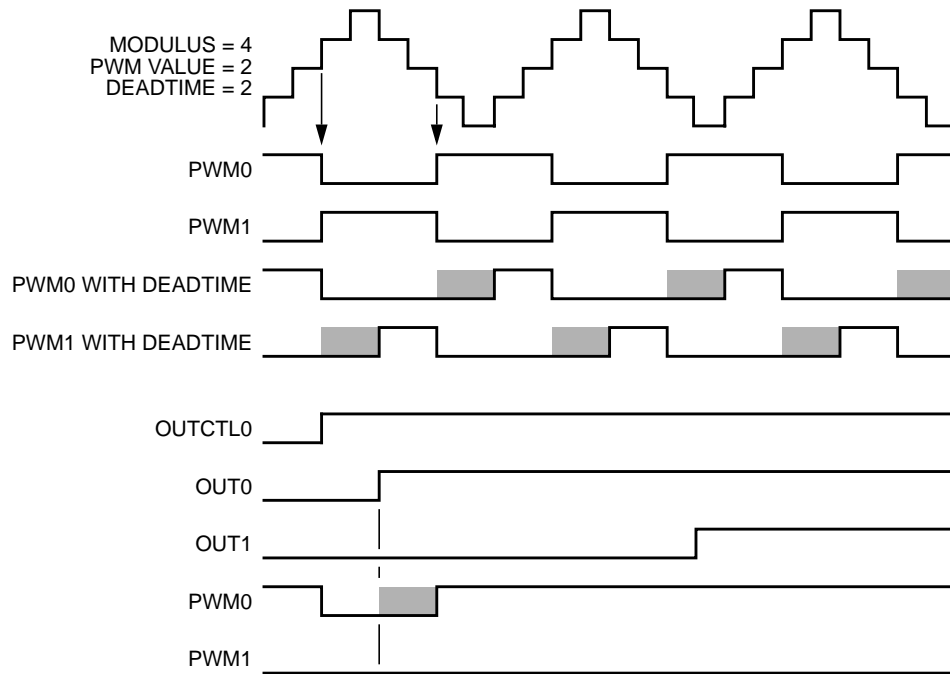

Figure 11-62. Setting OUT0 with OUTCTL Set in Complementary Mode

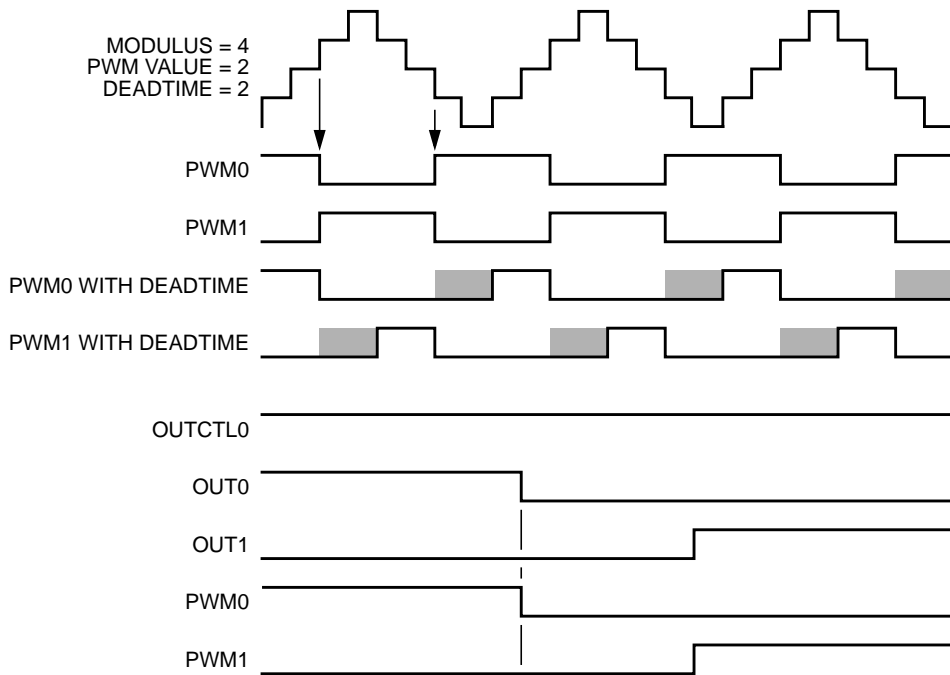

Figure 11-63. Clearing OUT0 with OUTCTL Set In Complementary Mode

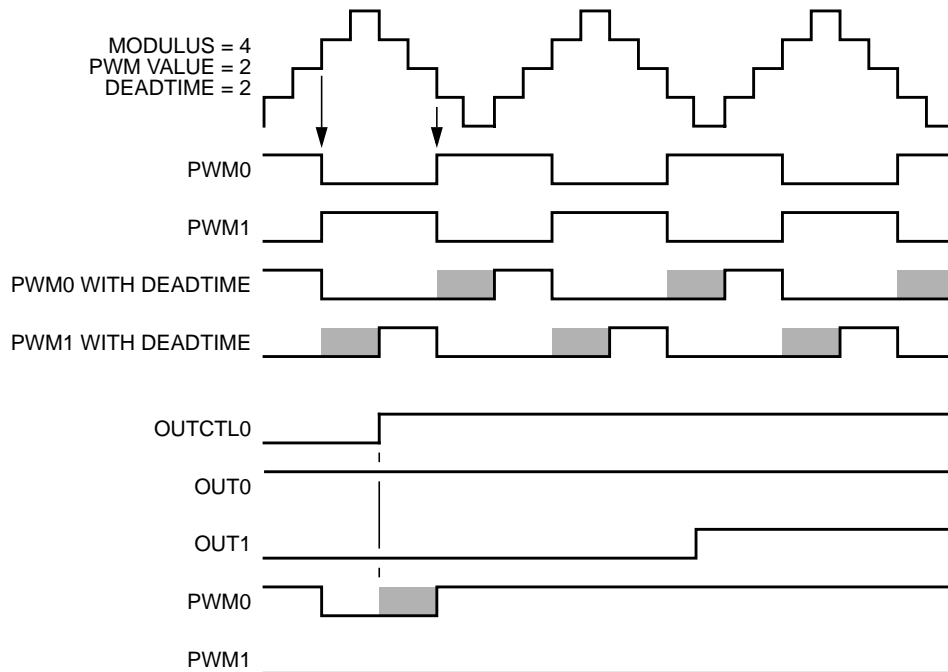

Figure 11-64. Setting OUTCTL with OUT0 Set in Complementary Mode

11.4.7 PWM Generator Loading

11.4.7.1 Load Enable

The load okay bit, LDOK, enables loading the PWM generator with:

- A prescaler divisor—from the PRSC1 and PRSC0 bits in PWM control register
- A PWM period—from the PWM counter modulus registers
- A PWM pulse width—from the PWM value registers

LDOK prevents reloading of these PWM parameters before software is finished calculating them. Setting LDOK allows the prescaler bits, PMFMOD and PMFVALx registers to be loaded into a set of buffers. The loaded buffers use the PWM generator at the beginning of the next PWM reload cycle. Set LDOK by reading it when it is a logic zero and then writing a logic one to it. After loading, LDOK is automatically cleared.

11.4.7.2 Load Frequency

The LDFQ3, LDFQ2, LDFQ1, and LDFQ0 bits in the PWM control register (PWMCTL) select an integral loading frequency of one to 16-PWM reload opportunities. The LDFQ bits take effect at every PWM reload opportunity, regardless the state of the load okay bit, LDOK. The *half* bit in the PWMCTL register controls half-cycle reloads for center-aligned PWMs. If the *half* bit is set, a reload opportunity occurs at the beginning of every PWM cycle and half cycle when the count equals the modulus. If the half bit is not set, a reload opportunity occurs only at the beginning of every cycle. Reload opportunities can only occur at the beginning of a PWM cycle in edge-aligned mode.

NOTE

Loading a new modulus on a half cycle will force the count to the new modulus value minus one on the next clock cycle. Half cycle reloads are possible only in center-aligned mode. Enabling or disabling half-cycle reloads in edge-aligned mode will have no effect on the reload rate.

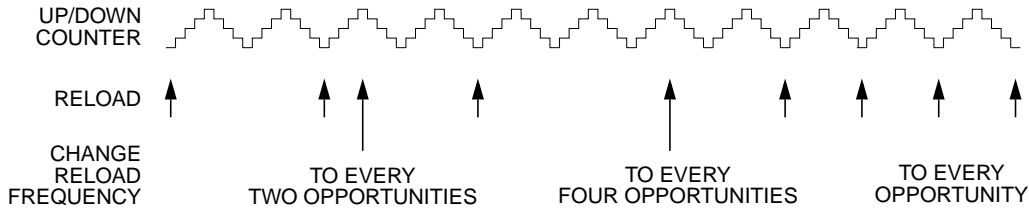

Figure 11-65. Full Cycle Reload Frequency Change

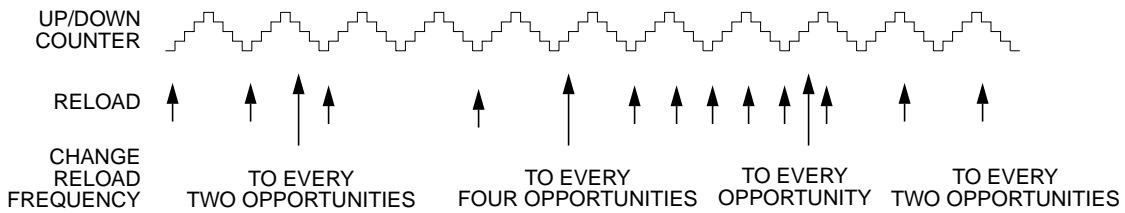

Figure 11-66. Half Cycle Reload Frequency Change

11.4.7.3 Reload Flag

With a reload opportunity, regardless an actual reload occurs as determined by LDOK bit, the PWMF reload flag is set. If the PWM reload interrupt enable bit, PWMRIE is set, the PWMF flag generates CPU interrupt requests allowing software to calculate new PWM parameters in real time. When PWMRIE is not set, reloads still occur at the selected reload rate without generating CPU interrupt requests.

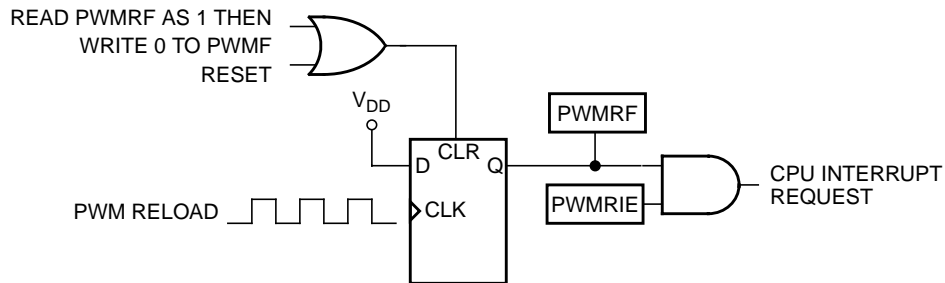

Figure 11-67. PWMRF Reload Interrupt Request

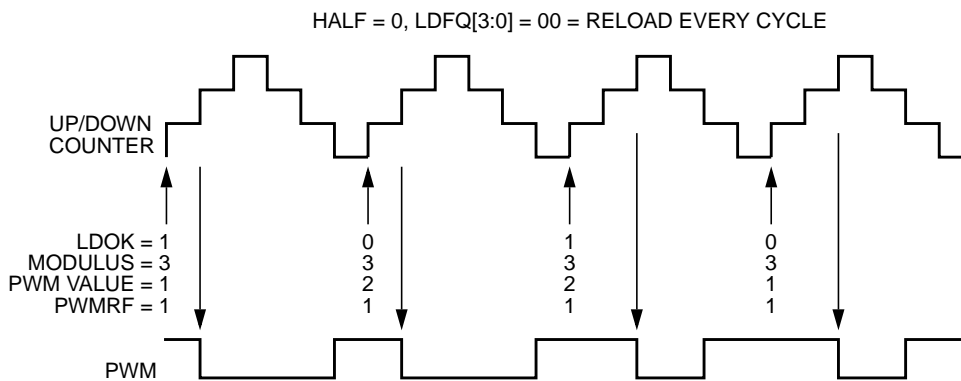

Figure 11-68. Full-Cycle Center-Aligned PWM Value Loading

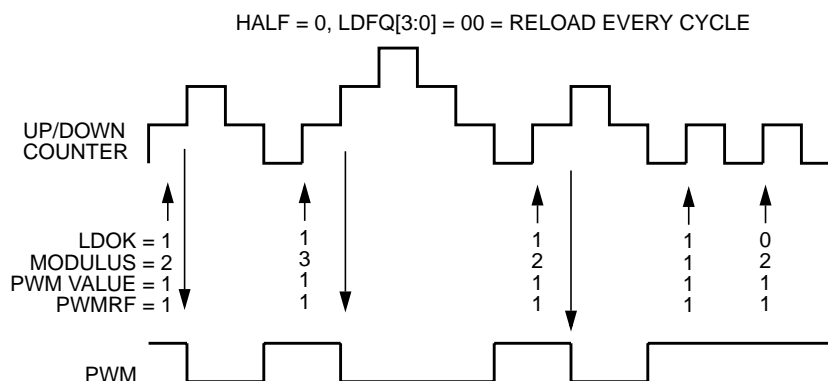

Figure 11-69. Full-Cycle Center-Aligned Modulus Loading

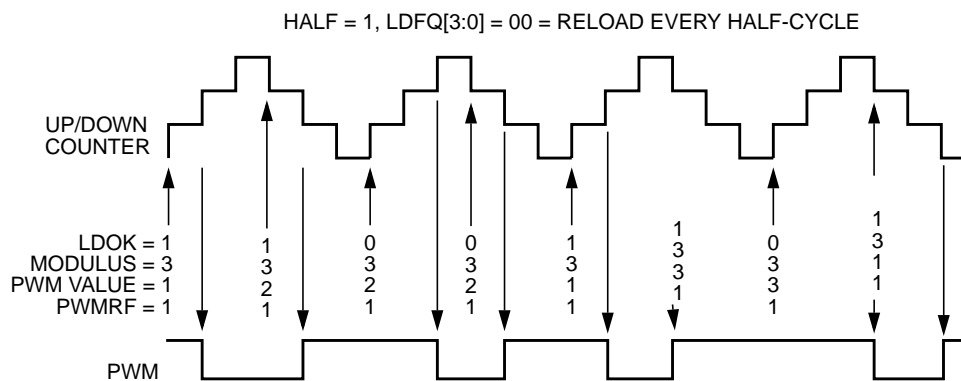

Figure 11-70. Half-Cycle Center-Aligned PWM Value Loading

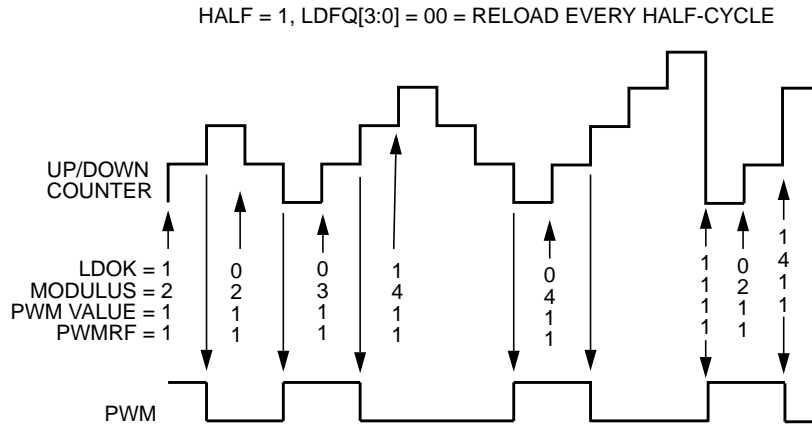

Figure 11-71. Half-Cycle Center-Aligned Modulus Loading

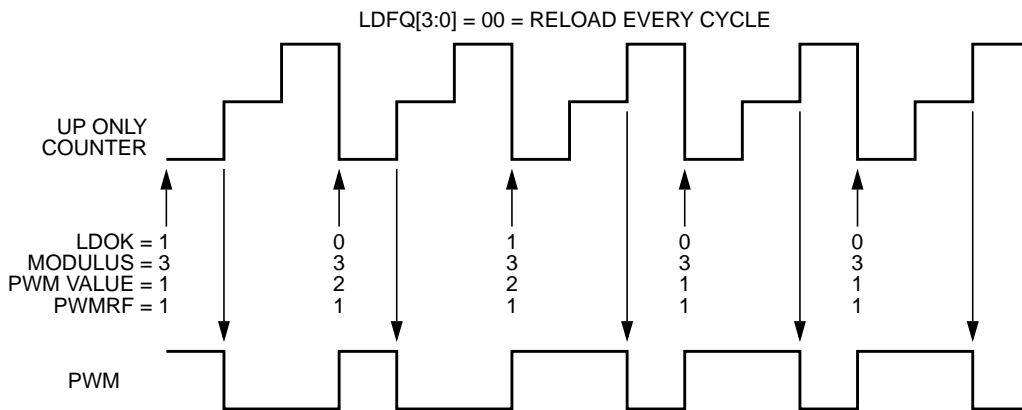

Figure 11-72. Edge-Aligned PWM Value Loading

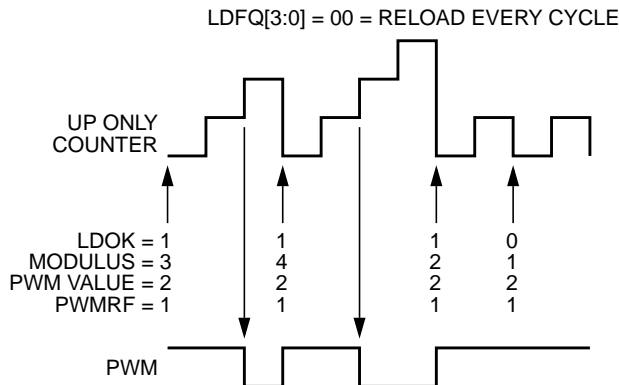

Figure 11-73. Untitled Figure

11.4.7.4 Initialization

Initialize all registers and set the LDOK bit before setting the PWMEN bit. With LDOK set, setting PWMEN for the first time after reset, immediately loads the PWM generator thereby setting the PWMRF flag. PWMRF generates a CPU interrupt request if the PWMRIE bit is set. In complementary channel

operation with current-status correction selected, PWM value registers one, three, and five control the outputs for the first PWM cycle.

NOTE

Even if LDOK is not set, setting PWMEN also sets the PWMRF flag. To prevent a CPU interrupt request, clear the PWMRIE bit before setting PWMEN.

Setting PWMEN for the first time after reset without first setting LDOK loads a prescaler divisor of one, a PWM value of \$0000, and an unknown modulus.

The PWM generator uses the last values loaded if PWMEN is cleared and then set while LDOK equals zero.

Initializing the deadtime register, after setting PWMEN or OUTCTLx, can cause an improper deadtime insertion. However, the deadtime can never be shorter than the specified value.

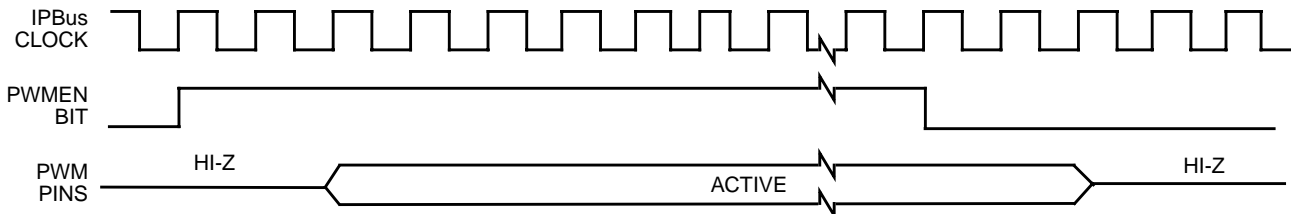

Figure 11-74. PWMEN and PWM Pins in Independent Operation

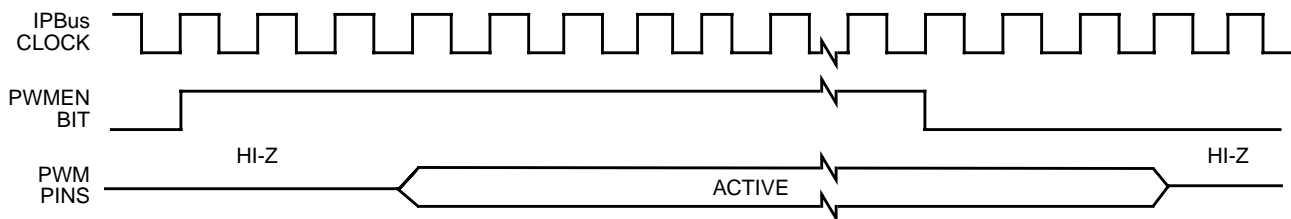

Figure 11-75. PWMEN and PWM Pins in Complementary Operation

When the PWMEN bit is cleared:

- The PWMx outputs will be tri-stated unless $OUTCTLx = 1$
- The PWM counter is cleared and does not count
- The PWM generator forces its outputs to zero
- The PWMRF flag and pending CPU interrupt requests are not cleared
- All fault circuitry remains active unless $FPINEx = 0$
- Software output control remains active
- Deadtime insertion continues during software output control

11.4.8 Fault Protection

Fault protection can disable any combination of PWM pins. Faults are generated by a logic one on any of the FAULT pins. Each FAULT pin can be mapped arbitrarily to any of the PWM pins.

When fault protection hardware disables PWM pins, the PWM generator continues to run, only the output pins are deactivated.

The fault decoder disables PWM pins selected by the fault logic and the disable mapping register. See [Figure 11-15](#). Each bank of four bits in the disable mapping register control the mapping for a single PWM pin. Refer to [Table 11-12](#).

The fault protection is enabled even when the PWM is not enabled; therefore, a fault will be latched in and will be cleared in order to prevent an interrupt when the PWM is enabled.

11.4.8.1 Fault Pin Sample Filter

Each fault pin has a sample filter to test for fault conditions. After every bus cycle setting the FAULTx pin at logic zero, the filter synchronously samples the pin once every four bus cycles. QSMP determines the number of consecutive samples that must be logic one for a fault to be detected. When a fault is detected, the corresponding FAULTx pin flag, FFLAGx, is set. Clear FFLAGx by writing a logic one to it.

If the FIEx, FAULTx pin interrupt enable bit is set, the FFLAGx flag generates a CPU interrupt request. The interrupt request latch remains set until:

- Software clears the FFLAGx flag by writing a logic one to it
- Software clears the FIEx bit by writing a logic zero to it
- A reset occurs

11.4.8.2 Automatic Fault Clearing

Setting a fault mode bit, FMODEx, configures faults from the FAULTx pin for automatic clearing.

When FMODEx is set, disabled PWM pins are enabled when the FAULTx pin returns to logic zero and a new PWM half cycle begins. See [Figure 11-76](#). Clearing the FFLAGx flag does not affect disabled PWM pins when FMODEx is set.

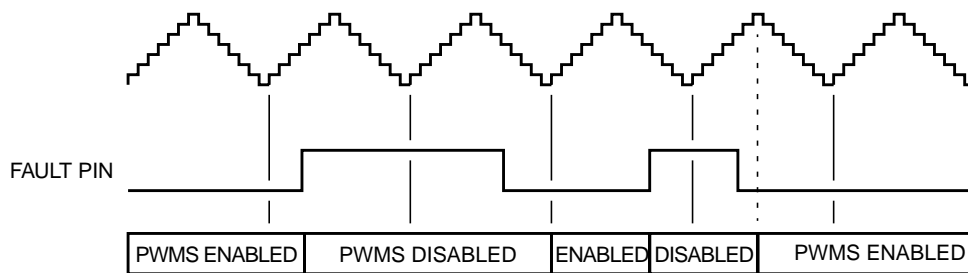

Figure 11-76. Automatic Fault Clearing

11.4.8.3 Manual Fault Clearing

Clearing a fault mode bit, FMODEx, configures faults from the FAULTx pin for manual clearing:

- PWM pins disabled by the FAULT0 pin or the FAULT2 pin are enabled by clearing the corresponding FFLAGx flag. The time at which the PWM pins are enabled depends on the corresponding QSMPx bit setting. If QSMPx = 00, the PWM pins are enabled on the next IP bus cycle when the logic level detected by the filter at the fault pin is logic zero. If QSMPx = 01, 10 or

11, the PWMs are enabled when the next PWM half cycle begins regardless of the state of the logic level detected by the filter at the fault. See [Figure 11-77](#) and [Figure 11-78](#).

- PWM pins disabled by the FAULT1 pin or the FAULT3 pin are enabled when
 - Software clears the corresponding FFLAGx flag
 - The filter detects a logic zero on the fault pin at the start of the next PWM half cycle boundary. See [Figure 11-79](#).

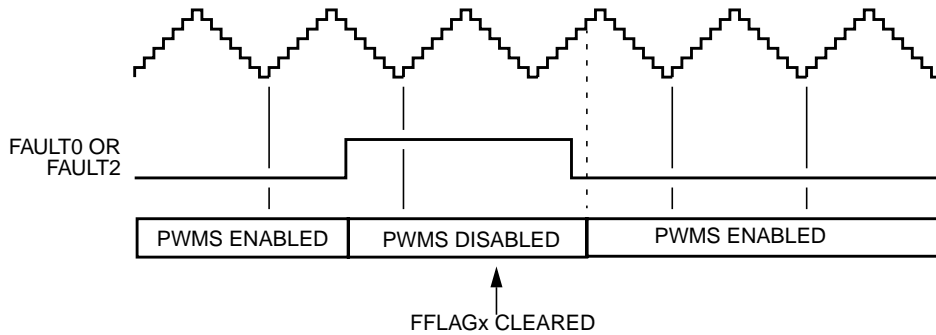

Figure 11-77. Manual Fault Clearing (Faults 0 and 2) — Q SMP = 00

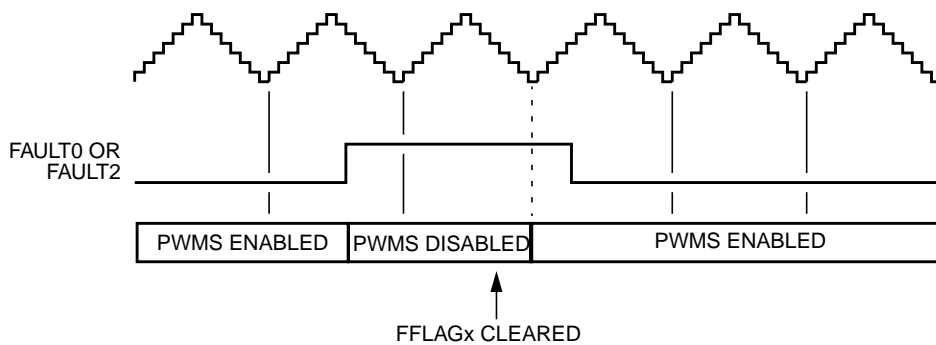

Figure 11-78. Manual Fault Clearing (Faults 0 and 2) — Q SMP = 01, 10, or 11

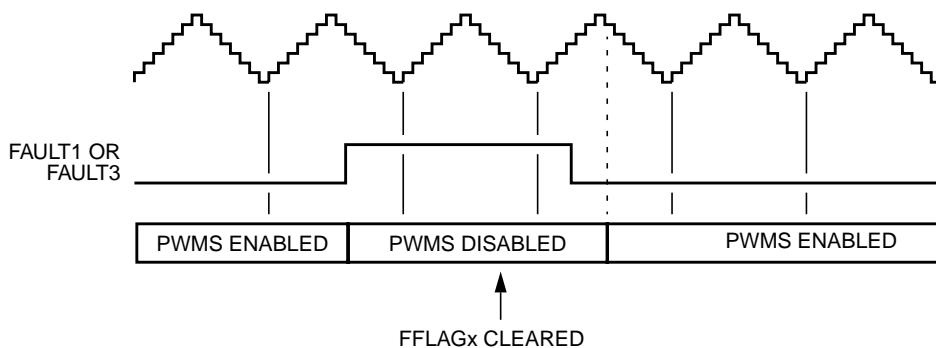

Figure 11-79. Manual Fault Clearing (Faults 1 and 3)

NOTE

PWM half-cycle boundaries occur at both the PWM cycle start and when the counter equals the modulus, so in edge-aligned operation full-cycles and half-cycles are equal.

NOTE

Fault protection also applies during software output control when the OUTCTLx bits are set. Fault clearing still occurs at half PWM cycle boundaries while the PWM generator is engaged, PWMEN equals one. But the OUTx bits can control the PWM pins while the PWM generator is off, PWMEN equals zero. Thus, fault clearing occurs at IPbus cycles while the PWM generator is off and at the start of PWM cycles when the generator is engaged.

11.5 Resets

All PWM registers are reset to their default values upon any system reset.

11.6 Clocks

The system bus clock is the only clock required by this module.

11.7 Interrupts

Seven PWM sources can generate CPU interrupt requests:

- Reload flag x (PWMRFx)—PWMRFx is set at the beginning of every PWM Generator x reload cycle. The reload interrupt enable bit, PWMRIEx, enables PWMRFx to generate CPU interrupt requests.
where x is A, B and C.
- Fault flag x (FFLAGx)—The FFLAGx bit is set when a logic one occurs on the FAULTx pin. The fault pin interrupt enable x bit, FIEEx, enables the FFLAGx flag to generate CPU interrupt requests.
where x is 0, 1, 2 and 3.

11.8 Electrical Specifications

In general, electrical specifications may vary a bit from chip to chip. This section illustrates typical parameters. Refer to the chip specification electrical and timing specifications for details of a specific implementation.

Table 11-41. DC Electrical Characteristics

Characteristic	Symbol	Min	Typ	Max	Unit
Input high voltage	V_{IH}	2.0	—	5.5	V
Input low voltage	V_{IL}	-0.3	—	0.8	V
Input hysteresis on Schmitt trigger inputs (Fault pins)	V_{HYS}	—	0.3	—	V
Input pullup current	I_{PU}	-50	-100	-170	∞ A
Input current low (pullups disabled)	I_{IL}	-10	—	10	∞ A
Input current high (pullups disabled)	I_{IH}	-10	—	10	∞ A
Output tri-state current low	I_{OZL}	-10	—	10	∞ A

Table 11-41. DC Electrical Characteristics (continued)

Characteristic	Symbol	Min	Typ	Max	Unit
Output tri-state current high	I_{OZH}	-10	—	10	∞ A
Output voltage high (at I_{OHP})	V_{OH}	$V_{DD} - 0.7$	—	—	V
Output voltage low (at I_{OLP})	V_{OL}	—	—	0.4	V
Input capacitance	C_{IN}	—	8	—	pF
Output capacitance	C_{OUT}	—	12	—	pF
PWM pin output high Current ⁽¹⁾ (at V_{OH-min})	I_{OHP}	-10	—	—	mA
PWM pin output low current ⁽²⁾ (at V_{OL-min})	I_{OLP}	16	—	—	mA

1. PWM pin output high current measured with 50% duty cycle.

2. PWM pin output low current measured with 50% duty cycle.



Chapter 12

Pulse-Width Modulator (PWM8B6CV1) Block Description

12.1 Introduction

The pulse width modulation (PWM) definition is based on the HC12 PWM definitions. The PWM8B6CV1 module contains the basic features from the HC11 with some of the enhancements incorporated on the HC12, that is center aligned output mode and four available clock sources. The PWM8B6CV1 module has six channels with independent control of left and center aligned outputs on each channel.

Each of the six PWM channels has a programmable period and duty cycle as well as a dedicated counter. A flexible clock select scheme allows a total of four different clock sources to be used with the counters. Each of the modulators can create independent continuous waveforms with software-selectable duty rates from 0% to 100%. The PWM outputs can be programmed as left aligned outputs or center aligned outputs

12.1.1 Features

- Six independent PWM channels with programmable period and duty cycle
- Dedicated counter for each PWM channel
- Programmable PWM enable/disable for each channel
- Software selection of PWM duty pulse polarity for each channel
- Period and duty cycle are double buffered. Change takes effect when the end of the effective period is reached (PWM counter reaches 0) or when the channel is disabled.
- Programmable center or left aligned outputs on individual channels
- Six 8-bit channel or three 16-bit channel PWM resolution
- Four clock sources (A, B, SA, and SB) provide for a wide range of frequencies.
- Programmable clock select logic
- Emergency shutdown

12.1.2 Modes of Operation

There is a software programmable option for low power consumption in wait mode that disables the input clock to the prescaler.

In freeze mode there is a software programmable option to disable the input clock to the prescaler. This is useful for emulation.

12.1.3 Block Diagram

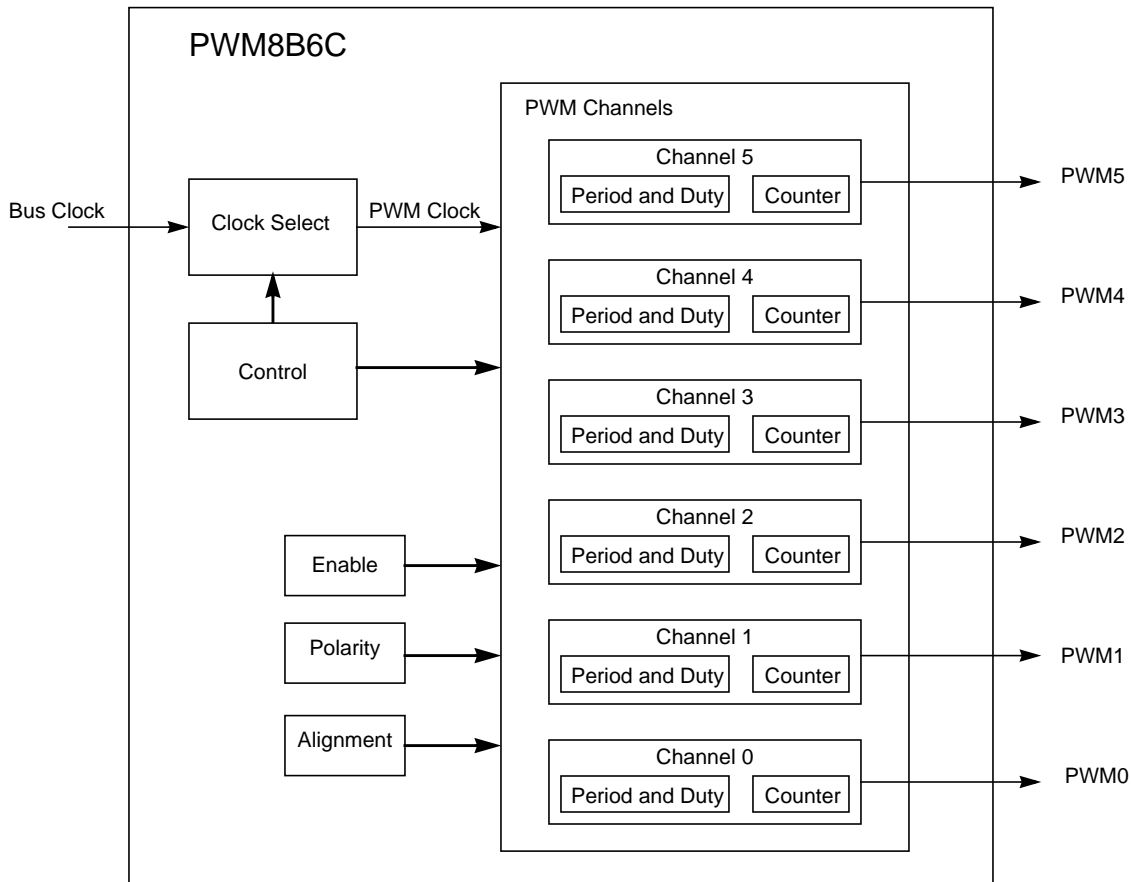

Figure 12-1. PWM8B6CV1 Block Diagram

12.2 External Signal Description

The PWM8B6CV1 module has a total of six external pins.

12.2.1 PWM5 — Pulse Width Modulator Channel 5 Pin

This pin serves as waveform output of PWM channel 5 and as an input for the emergency shutdown feature.

12.2.2 PWM4 — Pulse Width Modulator Channel 4 Pin

This pin serves as waveform output of PWM channel 4.

12.2.3 PWM3 — Pulse Width Modulator Channel 3 Pin

This pin serves as waveform output of PWM channel 3.

12.2.4 PWM2 — Pulse Width Modulator Channel 2 Pin

This pin serves as waveform output of PWM channel 2.

12.2.5 PWM1 — Pulse Width Modulator Channel 1 Pin

This pin serves as waveform output of PWM channel 1.

12.2.6 PWM0 — Pulse Width Modulator Channel 0 Pin

This pin serves as waveform output of PWM channel 0.

12.3 Memory Map and Register Definition

This subsection describes in detail all the registers and register bits in the PWM8B6CV1 module.

The special-purpose registers and register bit functions that would not normally be made available to device end users, such as factory test control registers and reserved registers are clearly identified by means of shading the appropriate portions of address maps and register diagrams. Notes explaining the reasons for restricting access to the registers and functions are also explained in the individual register descriptions.

12.3.1 Module Memory Map

The following paragraphs describe the content of the registers in the PWM8B6CV1 module. The base address of the PWM8B6CV1 module is determined at the MCU level when the MCU is defined. The register decode map is fixed and begins at the first address of the module address offset. [Table 12-1](#) shows the registers associated with the PWM and their relative offset from the base address. The register detail description follows the order in which they appear in the register map.

Reserved bits within a register will always read as 0 and the write will be unimplemented. Unimplemented functions are indicated by shading the bit.

[Table 12-1](#) shows the memory map for the PWM8B6CV1 module.

NOTE

Register address = base address + address offset, where the base address is defined at the MCU level and the address offset is defined at the module level.

Table 12-1. PWM8B6CV1 Memory Map

Address Offset	Register	Access
0x0000	PWM Enable Register (PWME)	R/W
0x0001	PWM Polarity Register (PWMPOL)	R/W
0x0002	PWM Clock Select Register (PWMCLK)	R/W
0x0003	PWM Prescale Clock Select Register (PWMPRCLK)	R/W
0x0004	PWM Center Align Enable Register (PWMCAE)	R/W
0x0005	PWM Control Register (PWMCTL)	R/W
0x0006	PWM Test Register (PWMTST) ¹	R/W
0x0007	PWM Prescale Counter Register (PWMPRSC) ²	R/W
0x0008	PWM Scale A Register (PWMSCLA)	R/W
0x0009	PWM Scale B Register (PWMSCLB)	R/W
0x000A	PWM Scale A Counter Register (PWMSCNTA) ³	R/W
0x000B	PWM Scale B Counter Register (PWMSCNTB) ⁴	R/W
0x000C	PWM Channel 0 Counter Register (PWMCNT0)	R/W
0x000D	PWM Channel 1 Counter Register (PWMCNT1)	R/W
0x000E	PWM Channel 2 Counter Register (PWMCNT2)	R/W
0x000F	PWM Channel 3 Counter Register (PWMCNT3)	R/W
0x0010	PWM Channel 4 Counter Register (PWMCNT4)	R/W
0x0011	PWM Channel 5 Counter Register (PWMCNT5)	R/W
0x0012	PWM Channel 0 Period Register (PWMPER0)	R/W
0x0013	PWM Channel 1 Period Register (PWMPER1)	R/W
0x0014	PWM Channel 2 Period Register (PWMPER2)	R/W
0x0015	PWM Channel 3 Period Register (PWMPER3)	R/W
0x0016	PWM Channel 4 Period Register (PWMPER4)	R/W
0x0017	PWM Channel 5 Period Register (PWMPER5)	R/W
0x0018	PWM Channel 0 Duty Register (PWMDTY0)	R/W
0x0019	PWM Channel 1 Duty Register (PWMDTY1)	R/W
0x001A	PWM Channel 2 Duty Register (PWMDTY2)	R/W
0x001B	PWM Channel 3 Duty Register (PWMDTY3)	R/W
0x001C	PWM Channel 4 Duty Register (PWMDTY4)	R/W
0x001D	PWM Channel 5 Duty Register (PWMDTY5)	R/W
0x001E	PWM Shutdown Register (PWMSDN)	R/W

¹ PWMTST is intended for factory test purposes only.

² PWMPRSC is intended for factory test purposes only.

³ PWMSCNTA is intended for factory test purposes only.

⁴ PWMSCNTB is intended for factory test purposes only.

12.3.2 Register Descriptions

The following paragraphs describe in detail all the registers and register bits in the PWM8B6CV1 module.

Register Name		Bit 7	6	5	4	3	2	1	Bit 0
0x0000 PWME	R	0	0	PWME5	PWME4	PWME3	PWME2	PWME1	PWME0
	W								
0x0001 PWMPOL	R	0	0	PPOL5	PPOL4	PPOL3	PPOL2	PPOL1	PPOL0
	W								
0x0002 PWMCLK	R	0	0	PCLK5	PCLK4	PCLK3	PCLK2	PCLK1	PCLK0
	W								
0x0003 PWMPRCLK	R	0	PCKB2	PCKB1	PCKB0	0	PCKA2	PCKA1	PCKA0
	W								
0x0004 PWMCAE	R	0	0	CAE5	CAE4	CAE2	CAE2	CAE1	CAE0
	W								
0x0005 PWMCTL	R	0	CON45	CON23	CON01	PSWAI	PFRZ	0	0
	W								
0x0006 PWMTST	R	0	0	0	0	0	0	0	0
	W								
0x0007 PWMPRSC	R	0	0	0	0	0	0	0	0
	W								
0x0008 PWMSCLA	R	Bit 7	6	5	4	3	2	1	Bit 0
	W								
0x0009 PWMSCLB	R	Bit 7	6	5	4	3	2	1	Bit 0
	W								
0x000A PWMSCNTA	R	0	0	0	0	0	0	0	0
	W								
0x000B PWMSCNTB	R	0	0	0	0	0	0	0	0
	W								
0x000C PWMCNT0	R	Bit 7	6	5	4	3	2	1	Bit 0
	W	0	0	0	0	0	0	0	0
0x000D PWMCNT1	R	Bit 7	6	5	4	3	2	1	Bit 0
	W	0	0	0	0	0	0	0	0
0x000E PWMCNT2	R	Bit 7	6	5	4	3	2	1	Bit 0
	W	0	0	0	0	0	0	0	0

= Unimplemented or Reserved

Figure 12-2. PWM Register Summary

Register Name		Bit 7	6	5	4	3	2	1	Bit 0
0x000F PWMCNT3	R	Bit 7	6	5	4	3	2	1	Bit 0
	W	0	0	0	0	0	0	0	0
0x0010 PWMCNT4	R	Bit 7	6	5	4	3	2	1	Bit 0
	W	0	0	0	0	0	0	0	0
0x0011 PWMCNT5	R	Bit 7	6	5	4	3	2	1	Bit 0
	W	0	0	0	0	0	0	0	0
0x0012 PWMPER0	R	Bit 7	6	5	4	3	2	1	Bit 0
	W	Bit 7	6	5	4	3	2	1	Bit 0
0x0013 PWMPER1	R	Bit 7	6	5	4	3	2	1	Bit 0
	W	Bit 7	6	5	4	3	2	1	Bit 0
0x0014 PWMPER2	R	Bit 7	6	5	4	3	2	1	Bit 0
	W	Bit 7	6	5	4	3	2	1	Bit 0
0x0015 PWMPER3	R	Bit 7	6	5	4	3	2	1	Bit 0
	W	Bit 7	6	5	4	3	2	1	Bit 0
0x0016 PWMPER4	R	Bit 7	6	5	4	3	2	1	Bit 0
	W	Bit 7	6	5	4	3	2	1	Bit 0
0x0017 PWMPER5	R	Bit 7	6	5	4	3	2	1	Bit 0
	W	Bit 7	6	5	4	3	2	1	Bit 0
0x0018 PWMDTY0	R	Bit 7	6	5	4	3	2	1	Bit 0
	W	Bit 7	6	5	4	3	2	1	Bit 0
0x0019 PWMPER1	R	Bit 7	6	5	4	3	2	1	Bit 0
	W	Bit 7	6	5	4	3	2	1	Bit 0
0x001A PWMPER2	R	Bit 7	6	5	4	3	2	1	Bit 0
	W	Bit 7	6	5	4	3	2	1	Bit 0
0x001B PWMPER3	R	Bit 7	6	5	4	3	2	1	Bit 0
	W	Bit 7	6	5	4	3	2	1	Bit 0
0x001C PWMPER4	R	Bit 7	6	5	4	3	2	1	Bit 0
	W	Bit 7	6	5	4	3	2	1	Bit 0
0x001D PWMPER5	R	Bit 7	6	5	4	3	2	1	Bit 0
	W	Bit 7	6	5	4	3	2	1	Bit 0
0x001E PWMSDB	R	PWMIF	PWMIE	0	PWMLVL	0	PWM5IN	PWM5INL	PWM5ENA
	W			PWMRSTR					

= Unimplemented or Reserved

Figure 12-2. PWM Register Summary (continued)

12.3.2.1 PWM Enable Register (PWME)

Each PWM channel has an enable bit (PWME_x) to start its waveform output. When any of the PWME_x bits are set (PWME_x = 1), the associated PWM output is enabled immediately. However, the actual PWM waveform is not available on the associated PWM output until its clock source begins its next cycle due to the synchronization of PWME_x and the clock source.

NOTE

The first PWM cycle after enabling the channel can be irregular.

An exception to this is when channels are concatenated. After concatenated mode is enabled (CON_{xx} bits set in PWMCTL register), enabling/disabling the corresponding 16-bit PWM channel is controlled by the low-order PWME_x bit. In this case, the high-order bytes PWME_x bits have no effect and their corresponding PWM output lines are disabled.

While in run mode, if all six PWM channels are disabled (PWME₅–PWME₀ = 0), the prescaler counter shuts off for power savings.

Module Base + 0x0000

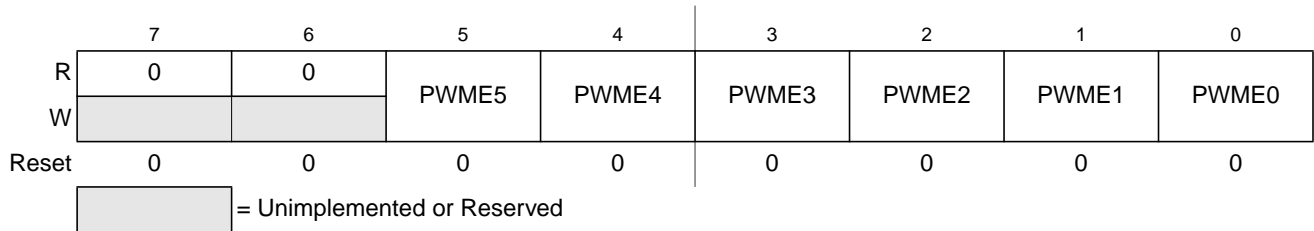

Figure 12-3. PWM Enable Register (PWME)

Read: anytime

Write: anytime

Table 12-2. PWME Field Descriptions

Field	Description
5 PWME5	Pulse Width Channel 5 Enable 0 Pulse width channel 5 is disabled. 1 Pulse width channel 5 is enabled. The pulse modulated signal becomes available at PWM, output bit 5 when its clock source begins its next cycle.
4 PWME4	Pulse Width Channel 4 Enable 0 Pulse width channel 4 is disabled. 1 Pulse width channel 4 is enabled. The pulse modulated signal becomes available at PWM, output bit 4 when its clock source begins its next cycle. If CON45 = 1, then bit has no effect and PWM output line 4 is disabled.
3 PWME3	Pulse Width Channel 3 Enable 0 Pulse width channel 3 is disabled. 1 Pulse width channel 3 is enabled. The pulse modulated signal becomes available at PWM, output bit 3 when its clock source begins its next cycle.
2 PWME2	Pulse Width Channel 2 Enable 0 Pulse width channel 2 is disabled. 1 Pulse width channel 2 is enabled. The pulse modulated signal becomes available at PWM, output bit 2 when its clock source begins its next cycle. If CON23 = 1, then bit has no effect and PWM output line 2 is disabled.

Table 12-2. PWME Field Descriptions (continued)

Field	Description
1 PWME1	Pulse Width Channel 1 Enable 0 Pulse width channel 1 is disabled. 1 Pulse width channel 1 is enabled. The pulse modulated signal becomes available at PWM, output bit 1 when its clock source begins its next cycle.
0 PWME0	Pulse Width Channel 0 Enable 0 Pulse width channel 0 is disabled. 1 Pulse width channel 0 is enabled. The pulse modulated signal becomes available at PWM, output bit 0 when its clock source begins its next cycle. If CON01 = 1, then bit has no effect and PWM output line 0 is disabled.

12.3.2.2 PWM Polarity Register (PWMPOL)

The starting polarity of each PWM channel waveform is determined by the associated PPOLx bit in the PWMPOL register. If the polarity bit is 1, the PWM channel output is high at the beginning of the cycle and then goes low when the duty count is reached. Conversely, if the polarity bit is 0 the output starts low and then goes high when the duty count is reached.

Module Base + 0x0001

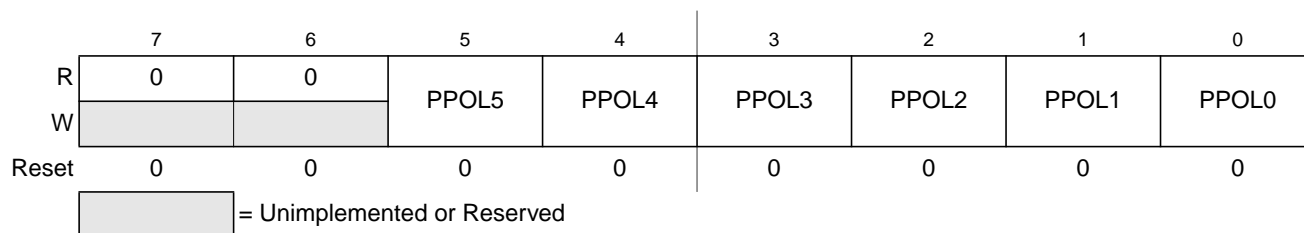
Figure 12-4. PWM Polarity Register (PWMPOL)

Read: anytime

Write: anytime

NOTE

PPOLx register bits can be written anytime. If the polarity is changed while a PWM signal is being generated, a truncated or stretched pulse can occur during the transition

Table 12-3. PWMPOL Field Descriptions

Field	Description
5 PPOL5	Pulse Width Channel 5 Polarity 0 PWM channel 5 output is low at the beginning of the period, then goes high when the duty count is reached. 1 PWM channel 5 output is high at the beginning of the period, then goes low when the duty count is reached.
4 PPOL4	Pulse Width Channel 4 Polarity 0 PWM channel 4 output is low at the beginning of the period, then goes high when the duty count is reached. 1 PWM channel 4 output is high at the beginning of the period, then goes low when the duty count is reached.

Table 12-3. PWMPOL Field Descriptions (continued)

Field	Description
3 PPOL3	Pulse Width Channel 3 Polarity 0 PWM channel 3 output is low at the beginning of the period, then goes high when the duty count is reached. 1 PWM channel 3 output is high at the beginning of the period, then goes low when the duty count is reached.
2 PPOL2	Pulse Width Channel 2 Polarity 0 PWM channel 2 output is low at the beginning of the period, then goes high when the duty count is reached. 1 PWM channel 2 output is high at the beginning of the period, then goes low when the duty count is reached.
1 PPOL1	Pulse Width Channel 1 Polarity 0 PWM channel 1 output is low at the beginning of the period, then goes high when the duty count is reached. 1 PWM channel 1 output is high at the beginning of the period, then goes low when the duty count is reached.
0 PPOL0	Pulse Width Channel 0 Polarity 0 PWM channel 0 output is low at the beginning of the period, then goes high when the duty count is reached. 1 PWM channel 0 output is high at the beginning of the period, then goes low when the duty count is reached.

12.3.2.3 PWM Clock Select Register (PWMCLK)

Each PWM channel has a choice of two clocks to use as the clock source for that channel as described below.

Module Base + 0x0002

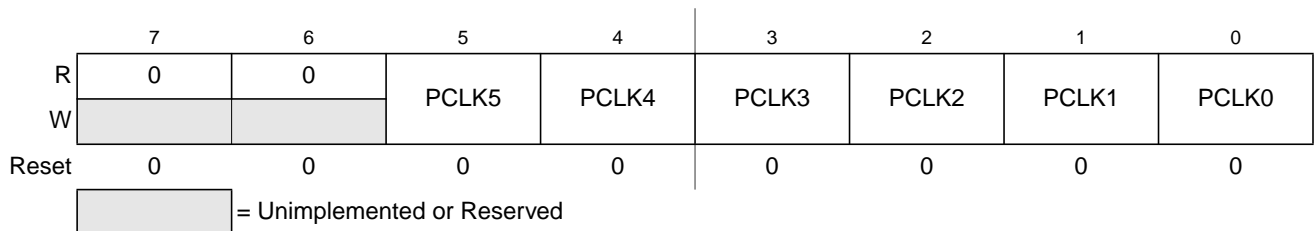

Figure 12-5. PWM Clock Select Register (PWMCLK)

Read: anytime

Write: anytime

NOTE

Register bits PCLK0 to PCLK5 can be written anytime. If a clock select is changed while a PWM signal is being generated, a truncated or stretched pulse can occur during the transition.

Table 12-4. PWMCLK Field Descriptions

Field	Description
5 PCLK5	Pulse Width Channel 5 Clock Select 0 Clock A is the clock source for PWM channel 5. 1 Clock SA is the clock source for PWM channel 5.
4 PCLK4	Pulse Width Channel 4 Clock Select 0 Clock A is the clock source for PWM channel 4. 1 Clock SA is the clock source for PWM channel 4.
3 PCLK3	Pulse Width Channel 3 Clock Select 0 Clock B is the clock source for PWM channel 3. 1 Clock SB is the clock source for PWM channel 3.
2 PCLK2	Pulse Width Channel 2 Clock Select 0 Clock B is the clock source for PWM channel 2. 1 Clock SB is the clock source for PWM channel 2.
1 PCLK1	Pulse Width Channel 1 Clock Select 0 Clock A is the clock source for PWM channel 1. 1 Clock SA is the clock source for PWM channel 1.
0 PCLK0	Pulse Width Channel 0 Clock Select 0 Clock A is the clock source for PWM channel 0. 1 Clock SA is the clock source for PWM channel 0.

12.3.2.4 PWM Prescale Clock Select Register (PWMPRCLK)

This register selects the prescale clock source for clocks A and B independently.

Module Base + 0x0003

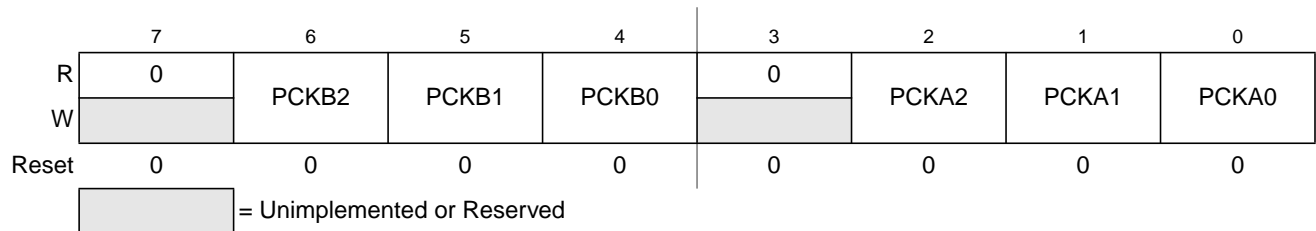

Figure 12-6. PWM Prescaler Clock Select Register (PWMPRCLK)

Read: anytime

Write: anytime

NOTE

PCKB2–PCKB0 and PCKA2–PCKA0 register bits can be written anytime. If the clock prescale is changed while a PWM signal is being generated, a truncated or stretched pulse can occur during the transition.

Table 12-5. PWMPRCLK Field Descriptions

Field	Description
6:5 PCKB[2:0]	Prescaler Select for Clock B — Clock B is 1 of two clock sources which can be used for channels 2 or 3. These three bits determine the rate of clock B, as shown in Table 12-6 .
2:0 PCKA[2:0]	Prescaler Select for Clock A — Clock A is 1 of two clock sources which can be used for channels 0, 1, 4, or 5. These three bits determine the rate of clock A, as shown in Table 12-7 .

Table 12-6. Clock B Prescaler Selects

PCKB2	PCKB1	PCKB0	Value of Clock B
0	0	0	Bus Clock
0	0	1	Bus Clock / 2
0	1	0	Bus Clock / 4
0	1	1	Bus Clock / 8
1	0	0	Bus Clock / 16
1	0	1	Bus Clock / 32
1	1	0	Bus Clock / 64
1	1	1	Bus Clock / 128

Table 12-7. Clock A Prescaler Selects

PCKA2	PCKA1	PCKA0	Value of Clock A
0	0	0	Bus Clock
0	0	1	Bus Clock / 2
0	1	0	Bus Clock / 4
0	1	1	Bus Clock / 8
1	0	0	Bus Clock / 16
1	0	1	Bus Clock / 32
1	1	0	Bus Clock / 64
1	1	1	Bus Clock / 128

12.3.2.5 PWM Center Align Enable Register (PWMCAE)

The PWMCAE register contains six control bits for the selection of center aligned outputs or left aligned outputs for each PWM channel. If the CAEx bit is set to a 1, the corresponding PWM output will be center aligned. If the CAEx bit is cleared, the corresponding PWM output will be left aligned. Reference [Section 12.4.2.5, “Left Aligned Outputs,”](#) and [Section 12.4.2.6, “Center Aligned Outputs,”](#) for a more detailed description of the PWM output modes.

Module Base + 0x0004

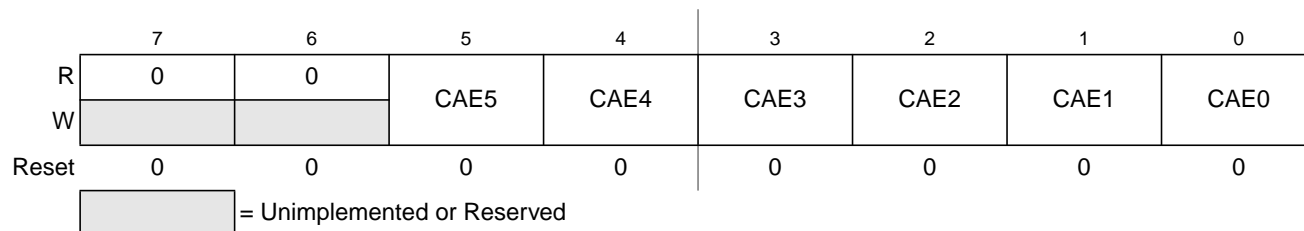

Figure 12-7. PWM Center Align Enable Register (PWMCAE)

Read: anytime

Write: anytime

NOTE

Write these bits only when the corresponding channel is disabled.

Table 12-8. PWMCAE Field Descriptions

Field	Description
5 CAE5	Center Aligned Output Mode on Channel 5 0 Channel 5 operates in left aligned output mode. 1 Channel 5 operates in center aligned output mode.
4 CAE4	Center Aligned Output Mode on Channel 4 0 Channel 4 operates in left aligned output mode. 1 Channel 4 operates in center aligned output mode.
3 CAE3	Center Aligned Output Mode on Channel 3 1 Channel 3 operates in left aligned output mode. 1 Channel 3 operates in center aligned output mode.
2 CAE2	Center Aligned Output Mode on Channel 2 0 Channel 2 operates in left aligned output mode. 1 Channel 2 operates in center aligned output mode.
1 CAE1	Center Aligned Output Mode on Channel 1 0 Channel 1 operates in left aligned output mode. 1 Channel 1 operates in center aligned output mode.
0 CAE0	Center Aligned Output Mode on Channel 0 0 Channel 0 operates in left aligned output mode. 1 Channel 0 operates in center aligned output mode.

12.3.2.6 PWM Control Register (PWMCTL)

The PWMCTL register provides for various control of the PWM module.

Module Base + 0x0005

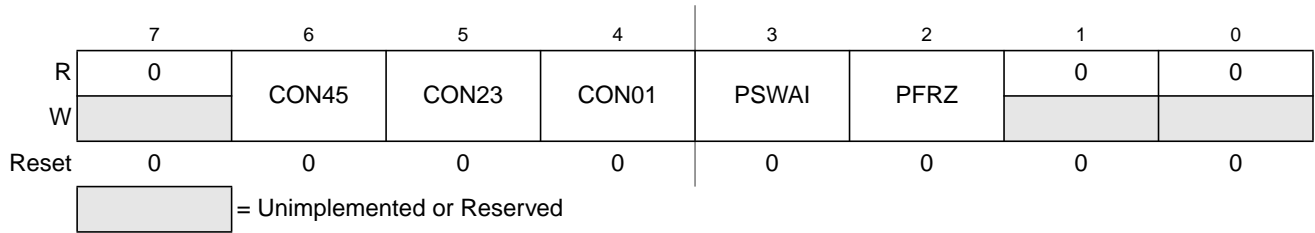

Figure 12-8. PWM Control Register (PWMCTL)

Read: anytime

Write: anytime

There are three control bits for concatenation, each of which is used to concatenate a pair of PWM channels into one 16-bit channel. When channels 4 and 5 are concatenated, channel 4 registers become the high-order bytes of the double-byte channel. When channels 2 and 3 are concatenated, channel 2 registers become the high-order bytes of the double-byte channel. When channels 0 and 1 are concatenated, channel 0 registers become the high-order bytes of the double-byte channel.

Reference [Section 12.4.2.7, “PWM 16-Bit Functions,”](#) for a more detailed description of the concatenation PWM function.

NOTE

Change these bits only when both corresponding channels are disabled.

Table 12-9. PWMCTL Field Descriptions

Field	Description
6 CON45	<p>Concatenate Channels 4 and 5</p> <p>0 Channels 4 and 5 are separate 8-bit PWMs.</p> <p>1 Channels 4 and 5 are concatenated to create one 16-bit PWM channel. Channel 4 becomes the high-order byte and channel 5 becomes the low-order byte. Channel 5 output pin is used as the output for this 16-bit PWM (bit 5 of port PWMP). Channel 5 clock select control bit determines the clock source, channel 5 polarity bit determines the polarity, channel 5 enable bit enables the output and channel 5 center aligned enable bit determines the output mode.</p>
5 CON23	<p>Concatenate Channels 2 and 3</p> <p>0 Channels 2 and 3 are separate 8-bit PWMs.</p> <p>1 Channels 2 and 3 are concatenated to create one 16-bit PWM channel. Channel 2 becomes the high-order byte and channel 3 becomes the low-order byte. Channel 3 output pin is used as the output for this 16-bit PWM (bit 3 of port PWMP). Channel 3 clock select control bit determines the clock source, channel 3 polarity bit determines the polarity, channel 3 enable bit enables the output and channel 3 center aligned enable bit determines the output mode.</p>
4 CON01	<p>Concatenate Channels 0 and 1</p> <p>0 Channels 0 and 1 are separate 8-bit PWMs.</p> <p>1 Channels 0 and 1 are concatenated to create one 16-bit PWM channel. Channel 0 becomes the high-order byte and channel 1 becomes the low-order byte. Channel 1 output pin is used as the output for this 16-bit PWM (bit 1 of port PWMP). Channel 1 clock select control bit determines the clock source, channel 1 polarity bit determines the polarity, channel 1 enable bit enables the output and channel 1 center aligned enable bit determines the output mode.</p>
3 PSWAI	<p>PWM Stops in Wait Mode — Enabling this bit allows for lower power consumption in wait mode by disabling the input clock to the prescaler.</p> <p>0 Allow the clock to the prescaler to continue while in wait mode.</p> <p>1 Stop the input clock to the prescaler whenever the MCU is in wait mode.</p>
2 PFRZ	<p>PWM Counters Stop in Freeze Mode — In freeze mode, there is an option to disable the input clock to the prescaler by setting the PFRZ bit in the PWMCTL register. If this bit is set, whenever the MCU is in freeze mode the input clock to the prescaler is disabled. This feature is useful during emulation as it allows the PWM function to be suspended. In this way, the counters of the PWM can be stopped while in freeze mode so that after normal program flow is continued, the counters are re-enabled to simulate real-time operations. Because the registers remain accessible in this mode, to re-enable the prescaler clock, either disable the PFRZ bit or exit freeze mode.</p> <p>0 Allow PWM to continue while in freeze mode.</p> <p>1 Disable PWM input clock to the prescaler whenever the part is in freeze mode. This is useful for emulation.</p>

12.3.2.7 Reserved Register (PWMTST)

This register is reserved for factory testing of the PWM module and is not available in normal modes.

Module Base + 0x0006

	7	6	5	4	3	2	1	0
R	0	0	0	0	0	0	0	0
W								
Reset	0	0	0	0	0	0	0	0

= Unimplemented or Reserved

Figure 12-9. Reserved Register (PWMTST)

Read: always read 0x0000 in normal modes

Write: unimplemented in normal modes

NOTE

Writing to this register when in special modes can alter the PWM functionality.

12.3.2.8 Reserved Register (PWMPRSC)

This register is reserved for factory testing of the PWM module and is not available in normal modes.

Module Base + 0x0007

	7	6	5	4	3	2	1	0
R	0	0	0	0	0	0	0	0
W								
Reset	0	0	0	0	0	0	0	0

= Unimplemented or Reserved

Figure 12-10. Reserved Register (PWMPRSC)

Read: always read 0x0000 in normal modes

Write: unimplemented in normal modes

NOTE

Writing to this register when in special modes can alter the PWM functionality.

12.3.2.9 PWM Scale A Register (PWMSCLA)

PWMSCLA is the programmable scale value used in scaling clock A to generate clock SA. Clock SA is generated by taking clock A, dividing it by the value in the PWMSCLA register and dividing that by two.

$$\text{Clock SA} = \text{Clock A} / (2 * \text{PWMSCLA})$$

NOTE

When PWMSCLA = 0x0000, PWMSCLA value is considered a full scale value of 256. Clock A is thus divided by 512.

Any value written to this register will cause the scale counter to load the new scale value (PWMSCLA).

Module Base + 0x0008

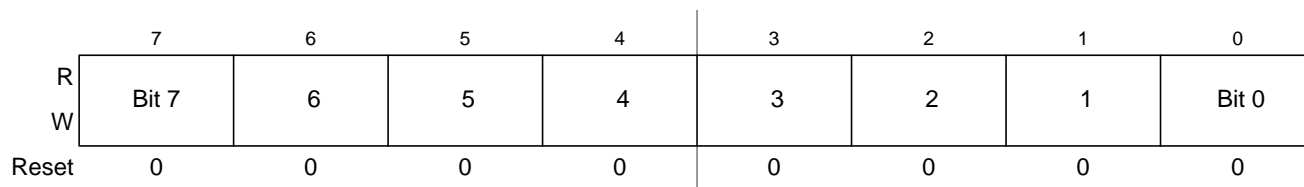

Figure 12-11. PWM Scale A Register (PWMSCLA)

Read: anytime

Write: anytime (causes the scale counter to load the PWMSCLA value)

12.3.2.10 PWM Scale B Register (PWMSCLB)

PWMSCLB is the programmable scale value used in scaling clock B to generate clock SB. Clock SB is generated by taking clock B, dividing it by the value in the PWMSCLB register and dividing that by two.

$$\text{Clock SB} = \text{Clock B} / (2 * \text{PWMSCLB})$$

NOTE

When PWMSCLB = 0x0000, PWMSCLB value is considered a full scale value of 256. Clock B is thus divided by 512.

Any value written to this register will cause the scale counter to load the new scale value (PWMSCLB).

Module Base + 0x0009

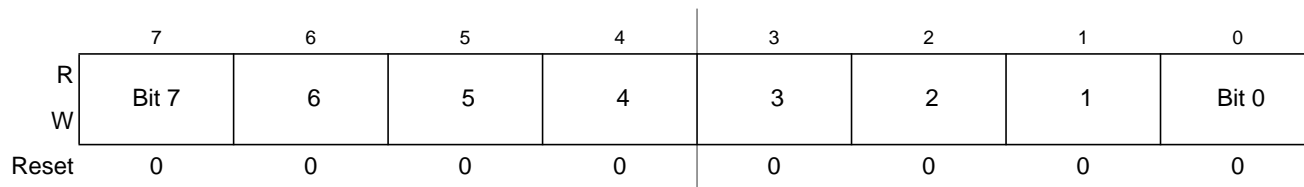

Figure 12-12. PWM Scale B Register (PWMSCLB)

Read: anytime

Write: anytime (causes the scale counter to load the PWMSCLB value).

12.3.2.11 Reserved Registers (PWMSCNTx)

The registers PWMSCNTA and PWMSCNTB are reserved for factory testing of the PWM module and are not available in normal modes.

Module Base + 0x000A

	7	6	5	4	3	2	1	0
R	0	0	0	0	0	0	0	0
W								
Reset	0	0	0	0	0	0	0	0

= Unimplemented or Reserved

Figure 12-13. Reserved Register (PWMSCNTA)

Module Base + 0x000B

	7	6	5	4	3	2	1	0
R	0	0	0	0	0	0	0	0
W								
Reset	0	0	0	0	0	0	0	0

= Unimplemented or Reserved

Figure 12-14. Reserved Register (PWMSCNTB)

Read: always read 0x0000 in normal modes

Write: unimplemented in normal modes

NOTE

Writing to these registers when in special modes can alter the PWM functionality.

12.3.2.12 PWM Channel Counter Registers (PWMCNTx)

Each channel has a dedicated 8-bit up/down counter which runs at the rate of the selected clock source. The counter can be read at any time without affecting the count or the operation of the PWM channel. In left aligned output mode, the counter counts from 0 to the value in the period register – 1. In center aligned output mode, the counter counts from 0 up to the value in the period register and then back down to 0.

Any value written to the counter causes the counter to reset to 0x0000, the counter direction to be set to up, the immediate load of both duty and period registers with values from the buffers, and the output to change according to the polarity bit. The counter is also cleared at the end of the effective period (see Section 12.4.2.5, “Left Aligned Outputs,” and Section 12.4.2.6, “Center Aligned Outputs,” for more details). When the channel is disabled (PWME_x = 0), the PWMCNT_x register does not count. When a channel becomes enabled (PWME_x = 1), the associated PWM counter starts at the count in the PWMCNT_x register. For more detailed information on the operation of the counters, reference Section 12.4.2.4, “PWM Timer Counters.”

In concatenated mode, writes to the 16-bit counter by using a 16-bit access or writes to either the low- or high-order byte of the counter will reset the 16-bit counter. Reads of the 16-bit counter must be made by 16-bit access to maintain data coherency.

NOTE

Writing to the counter while the channel is enabled can cause an irregular PWM cycle to occur.

Module Base + 0x000C

	7	6	5	4	3	2	1	0
R	Bit 7	6	5	4	3	2	1	Bit 0
W	0	0	0	0	0	0	0	0
Reset	0	0	0	0	0	0	0	0

Figure 12-15. PWM Channel Counter Registers (PWMCNT0)

Module Base + 0x000D

	7	6	5	4	3	2	1	0
R	Bit 7	6	5	4	3	2	1	Bit 0
W	0	0	0	0	0	0	0	0
Reset	0	0	0	0	0	0	0	0

Figure 12-16. PWM Channel Counter Registers (PWMCNT1)

Module Base + 0x000E

	7	6	5	4	3	2	1	0
R	Bit 7	6	5	4	3	2	1	Bit 0
W	0	0	0	0	0	0	0	0
Reset	0	0	0	0	0	0	0	0

Figure 12-17. PWM Channel Counter Registers (PWMCNT2)

Module Base + 0x000F

	7	6	5	4	3	2	1	0
R	Bit 7	6	5	4	3	2	1	Bit 0
W	0	0	0	0	0	0	0	0
Reset	0	0	0	0	0	0	0	0

Figure 12-18. PWM Channel Counter Registers (PWMCNT3)

Module Base + 0x00010

	7	6	5	4	3	2	1	0
R	Bit 7	6	5	4	3	2	1	Bit 0
W	0	0	0	0	0	0	0	0
Reset	0	0	0	0	0	0	0	0

Figure 12-19. PWM Channel Counter Registers (PWMCNT4)

Module Base + 0x00011

	7	6	5	4	3	2	1	0
R	Bit 7	6	5	4	3	2	1	Bit 0
W	0	0	0	0	0	0	0	0
Reset	0	0	0	0	0	0	0	0

Figure 12-20. PWM Channel Counter Registers (PWMCNT5)

Read: anytime

Write: anytime (any value written causes PWM counter to be reset to 0x0000).

12.3.2.13 PWM Channel Period Registers (PWMPERx)

There is a dedicated period register for each channel. The value in this register determines the period of the associated PWM channel.

The period registers for each channel are double buffered so that if they change while the channel is enabled, the change will NOT take effect until one of the following occurs:

- The effective period ends
- The counter is written (counter resets to 0x0000)

- The channel is disabled

In this way, the output of the PWM will always be either the old waveform or the new waveform, not some variation in between. If the channel is not enabled, then writes to the period register will go directly to the latches as well as the buffer.

NOTE

Reads of this register return the most recent value written. Reads do not necessarily return the value of the currently active period due to the double buffering scheme.

Reference [Section 12.4.2.3, “PWM Period and Duty,”](#) for more information.

To calculate the output period, take the selected clock source period for the channel of interest (A, B, SA, or SB) and multiply it by the value in the period register for that channel:

- Left aligned output (CAEx = 0)
- PWMx period = channel clock period * PWMPERx center aligned output (CAEx = 1)
- PWMx period = channel clock period * (2 * PWMPERx)

For boundary case programming values, please refer to [Section 12.4.2.8, “PWM Boundary Cases.”](#)

Module Base + 0x0012

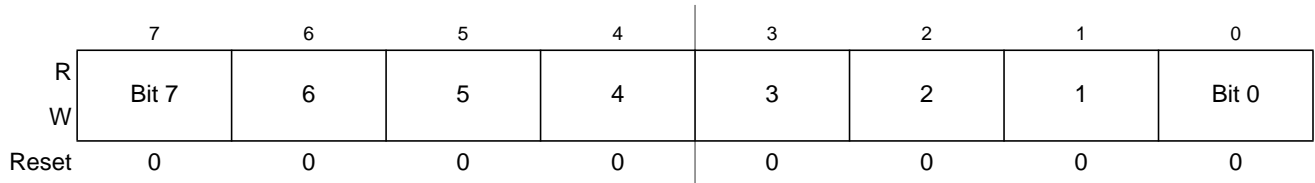

Figure 12-21. PWM Channel Period Registers (PWMPER0)

Module Base + 0x0013

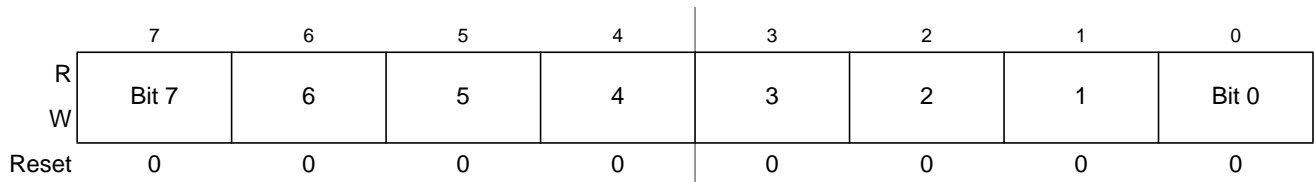

Figure 12-22. PWM Channel Period Registers (PWMPER1)

Module Base + 0x0014

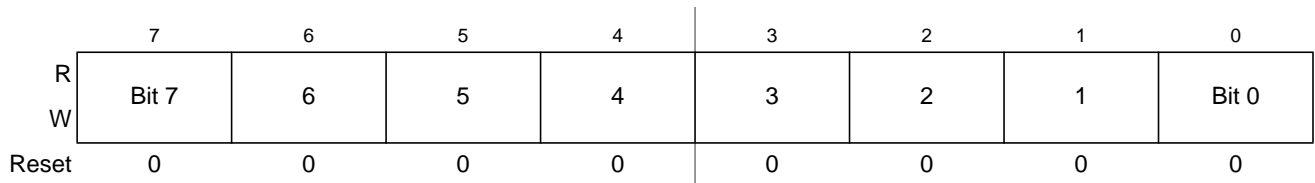

Figure 12-23. PWM Channel Period Registers (PWMPER2)

Module Base + 0x0015

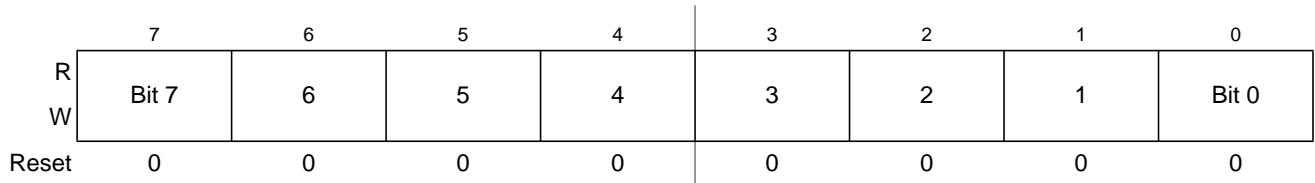

Figure 12-24. PWM Channel Period Registers (PWMPER3)

Module Base + 0x0016

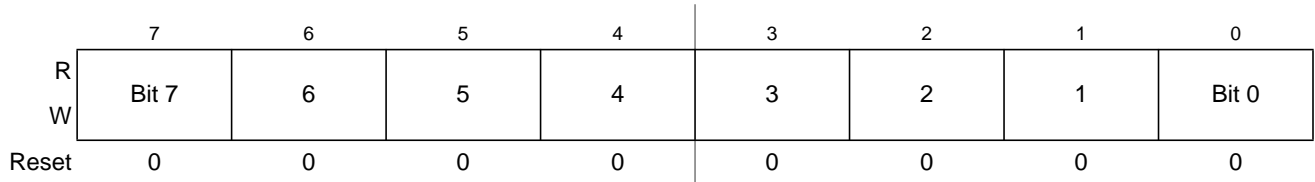

Figure 12-25. PWM Channel Period Registers (PWMPER4)

Module Base + 0x0017

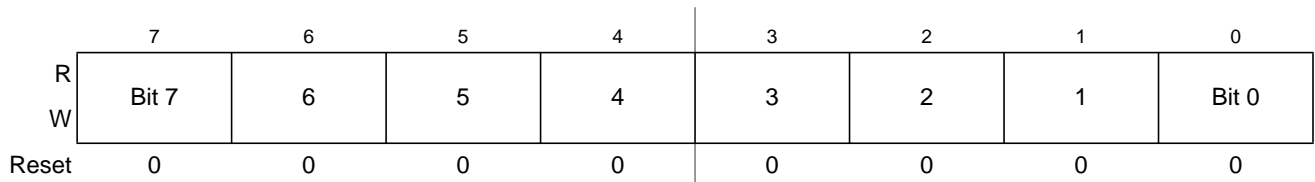

Figure 12-26. PWM Channel Period Registers (PWMPER5)

Read: anytime

Write: anytime

12.3.2.14 PWM Channel Duty Registers (PWMDTYx)

There is a dedicated duty register for each channel. The value in this register determines the duty of the associated PWM channel. The duty value is compared to the counter and if it is equal to the counter value a match occurs and the output changes state.

The duty registers for each channel are double buffered so that if they change while the channel is enabled, the change will NOT take effect until one of the following occurs:

- The effective period ends
- The counter is written (counter resets to 0x0000)
- The channel is disabled

In this way, the output of the PWM will always be either the old duty waveform or the new duty waveform, not some variation in between. If the channel is not enabled, then writes to the duty register will go directly to the latches as well as the buffer.

NOTE

Reads of this register return the most recent value written. Reads do not necessarily return the value of the currently active duty due to the double buffering scheme.

Reference [Section 12.4.2.3, “PWM Period and Duty,”](#) for more information.

NOTE

Depending on the polarity bit, the duty registers will contain the count of either the high time or the low time. If the polarity bit is 1, the output starts high and then goes low when the duty count is reached, so the duty registers contain a count of the high time. If the polarity bit is 0, the output starts low and then goes high when the duty count is reached, so the duty registers contain a count of the low time.

To calculate the output duty cycle (high time as a % of period) for a particular channel:

- Polarity = 0 (PPOL_x = 0)

$$\text{Duty cycle} = [(PWMPER_x \text{ PWMDTY}_x) / PWMPER_x] * 100\%$$
- Polarity = 1 (PPOL_x = 1)

$$\text{Duty cycle} = [PWMDTY_x / PWMPER_x] * 100\%$$
- For boundary case programming values, please refer to [Section 12.4.2.8, “PWM Boundary Cases.”](#)

Module Base + 0x0018

	7	6	5	4	3	2	1	0
R	Bit 7	6	5	4	3	2	1	Bit 0
W								
Reset	1	1	1	1	1	1	1	1

Figure 12-27. PWM Channel Duty Registers (PWMDTY0)

Module Base + 0x0019

	7	6	5	4	3	2	1	0
R	Bit 7	6	5	4	3	2	1	Bit 0
W								
Reset	1	1	1	1	1	1	1	1

Figure 12-28. PWM Channel Duty Registers (PWMDTY1)

Module Base + 0x001A

	7	6	5	4	3	2	1	0
R	Bit 7	6	5	4	3	2	1	Bit 0
W								
Reset	1	1	1	1	1	1	1	1

Figure 12-29. PWM Channel Duty Registers (PWMDTY2)

Module Base + 0x001B

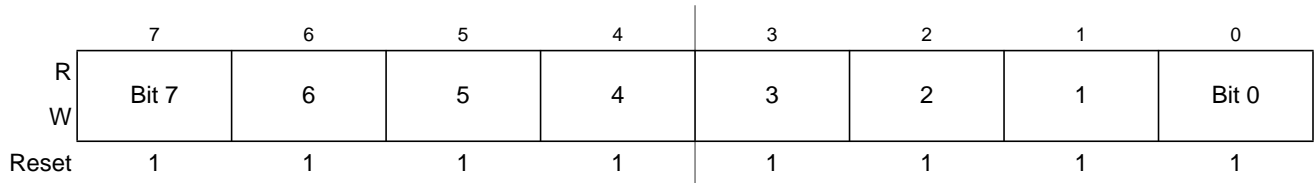

Figure 12-30. PWM Channel Duty Registers (PWMDTY3)

Module Base + 0x001C

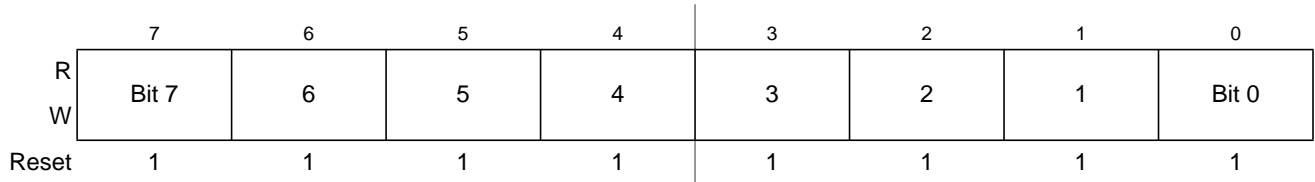

Figure 12-31. PWM Channel Duty Registers (PWMDTY4)

Module Base + 0x001D

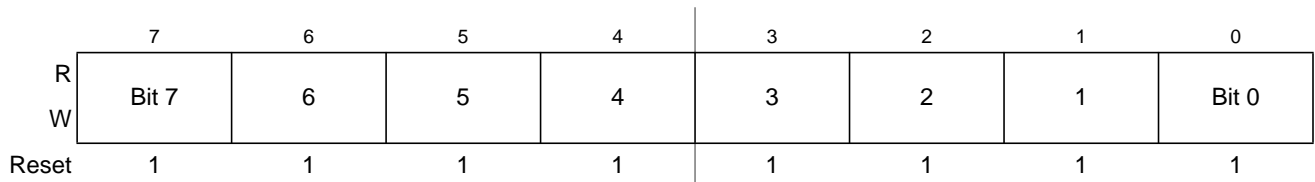

Figure 12-32. PWM Channel Duty Registers (PWMDTY5)

Read: anytime

Write: anytime

12.3.2.15 PWM Shutdown Register (PWMSDN)

The PWMSDN register provides for the shutdown functionality of the PWM module in the emergency cases.

Module Base + 0x00E

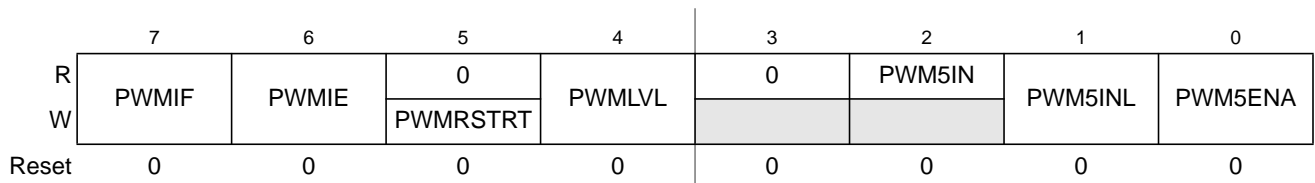

= Unimplemented or Reserved

Figure 12-33. PWM Shutdown Register (PWMSDN)

Read: anytime

Write: anytime

Table 12-10. PWMSDN Field Descriptions

Field	Description
7 PWMIF	PWM Interrupt Flag — Any change from passive to asserted (active) state or from active to passive state will be flagged by setting the PWMIF flag = 1. The flag is cleared by writing a logic 1 to it. Writing a 0 has no effect. 0 No change on PWM5IN input. 1 Change on PWM5IN input
6 PWMIE	PWM Interrupt Enable — If interrupt is enabled an interrupt to the CPU is asserted. 0 PWM interrupt is disabled. 1 PWM interrupt is enabled.
5 PWMRSTRT	PWM Restart — The PWM can only be restarted if the PWM channel input 5 is deasserted. After writing a logic 1 to the PWMRSTRT bit (trigger event) the PWM channels start running after the corresponding counter passes next “counter = 0” phase. Also, if the PWM5ENA bit is reset to 0, the PWM do not start before the counter passes 0x0000. The bit is always read as 0.
4 PWMLVL	PWM Shutdown Output Level — If active level as defined by the PWM5IN input, gets asserted all enabled PWM channels are immediately driven to the level defined by PWMLVL. 0 PWM outputs are forced to 0 1 PWM outputs are forced to 1.
2 PWM5IN	PWM Channel 5 Input Status — This reflects the current status of the PWM5 pin.
1 PWM5INL	PWM Shutdown Active Input Level for Channel 5 — If the emergency shutdown feature is enabled (PWM5ENA = 1), this bit determines the active level of the PWM5 channel. 0 Active level is low 1 Active level is high
0 PWM5ENA	PWM Emergency Shutdown Enable — If this bit is logic 1 the pin associated with channel 5 is forced to input and the emergency shutdown feature is enabled. All the other bits in this register are meaningful only if PWM5ENA = 1. 0 PWM emergency feature disabled. 1 PWM emergency feature is enabled.

12.4 Functional Description

12.4.1 PWM Clock Select

There are four available clocks called clock A, clock B, clock SA (scaled A), and clock SB (scaled B). These four clocks are based on the bus clock.

Clock A and B can be software selected to be 1, 1/2, 1/4, 1/8, ..., 1/64, 1/128 times the bus clock. Clock SA uses clock A as an input and divides it further with a reloadable counter. Similarly, clock SB uses clock B as an input and divides it further with a reloadable counter. The rates available for clock SA are software selectable to be clock A divided by 2, 4, 6, 8, ..., or 512 in increments of divide by 2. Similar rates are available for clock SB. Each PWM channel has the capability of selecting one of two clocks, either the pre-scaled clock (clock A or B) or the scaled clock (clock SA or SB).

The block diagram in [Figure 12-34](#) shows the four different clocks and how the scaled clocks are created.

12.4.1.1 Prescale

The input clock to the PWM prescaler is the bus clock. It can be disabled whenever the part is in freeze mode by setting the PFRZ bit in the PWMCTL register. If this bit is set, whenever the MCU is in freeze mode the input clock to the prescaler is disabled. This is useful for emulation in order to freeze the PWM. The input clock can also be disabled when all six PWM channels are disabled ($PWME5-PWME0 = 0$). This is useful for reducing power by disabling the prescale counter.

Clock A and clock B are scaled values of the input clock. The value is software selectable for both clock A and clock B and has options of 1, 1/2, 1/4, 1/8, 1/16, 1/32, 1/64, or 1/128 times the bus clock. The value selected for clock A is determined by the PCKA2, PCKA1, and PCKA0 bits in the PWMPRCLK register. The value selected for clock B is determined by the PCKB2, PCKB1, and PCKB0 bits also in the PWMPRCLK register.

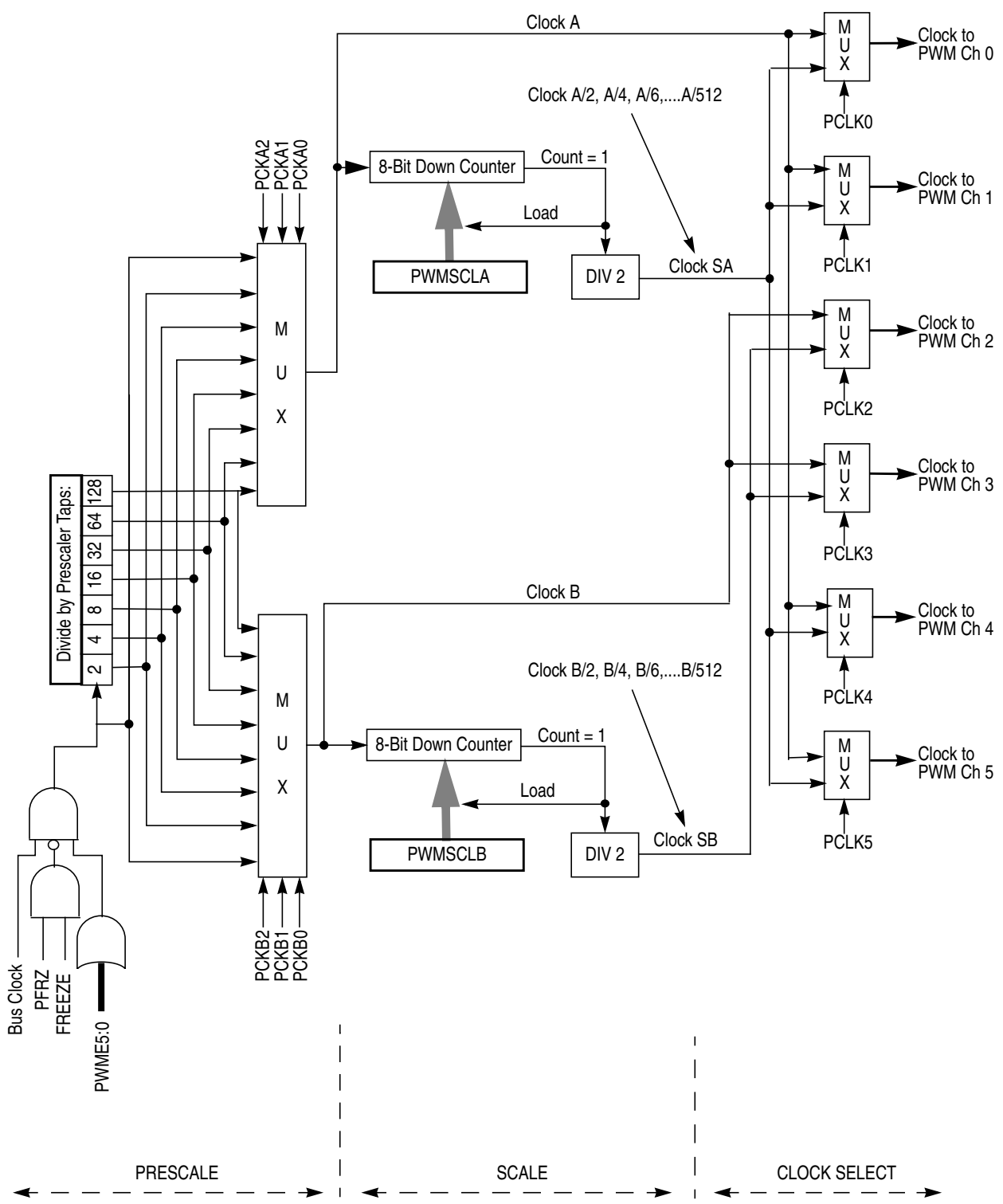

Figure 12-34. PWM Clock Select Block Diagram

12.4.1.2 Clock Scale

The scaled A clock uses clock A as an input and divides it further with a user programmable value and then divides this by 2. The scaled B clock uses clock B as an input and divides it further with a user programmable value and then divides this by 2. The rates available for clock SA are software selectable to be clock A divided by 2, 4, 6, 8, ..., or 512 in increments of divide by 2. Similar rates are available for clock SB.

Clock A is used as an input to an 8-bit down counter. This down counter loads a user programmable scale value from the scale register (PWMSCLA). When the down counter reaches 1, two things happen; a pulse is output and the 8-bit counter is re-loaded. The output signal from this circuit is further divided by two.

This gives a greater range with only a slight reduction in granularity. Clock SA equals clock A divided by two times the value in the PWMSCLA register.

NOTE

$$\text{Clock SA} = \text{Clock A} / (2 * \text{PWMSCLA})$$

When PWMSCLA = 0x0000, PWMSCLA value is considered a full scale value of 256. Clock A is thus divided by 512.

Similarly, clock B is used as an input to an 8-bit down counter followed by a divide by two producing clock SB. Thus, clock SB equals clock B divided by two times the value in the PWMSCLB register.

NOTE

$$\text{Clock SB} = \text{Clock B} / (2 * \text{PWMSCLB})$$

When PWMSCLB = 0x0000, PWMSCLB value is considered a full scale value of 256. Clock B is thus divided by 512.

As an example, consider the case in which the user writes 0x00FF into the PWMSCLA register. Clock A for this case will be bus clock divided by 4. A pulse will occur at a rate of once every 255 x 4 bus cycles. Passing this through the divide by two circuit produces a clock signal at a bus clock divided by 2040 rate. Similarly, a value of 0x0001 in the PWMSCLA register when clock A is bus clock divided by 4 will produce a bus clock divided by 8 rate.

Writing to PWMSCLA or PWMSCLB causes the associated 8-bit down counter to be re-loaded. Otherwise, when changing rates the counter would have to count down to 0x0001 before counting at the proper rate. Forcing the associated counter to re-load the scale register value every time PWMSCLA or PWMSCLB is written prevents this.

NOTE

Writing to the scale registers while channels are operating can cause irregularities in the PWM outputs.

12.4.1.3 Clock Select

Each PWM channel has the capability of selecting one of two clocks. For channels 0, 1, 4, and 5 the clock choices are clock A or clock SA. For channels 2 and 3 the choices are clock B or clock SB. The clock selection is done with the PCLKx control bits in the PWMCLK register.

NOTE

Changing clock control bits while channels are operating can cause irregularities in the PWM outputs.

12.4.2 PWM Channel Timers

The main part of the PWM module are the actual timers. Each of the timer channels has a counter, a period register and a duty register (each are 8 bit). The waveform output period is controlled by a match between the period register and the value in the counter. The duty is controlled by a match between the duty register and the counter value and causes the state of the output to change during the period. The starting polarity of the output is also selectable on a per channel basis. [Figure 12-35](#) shows a block diagram for PWM timer.

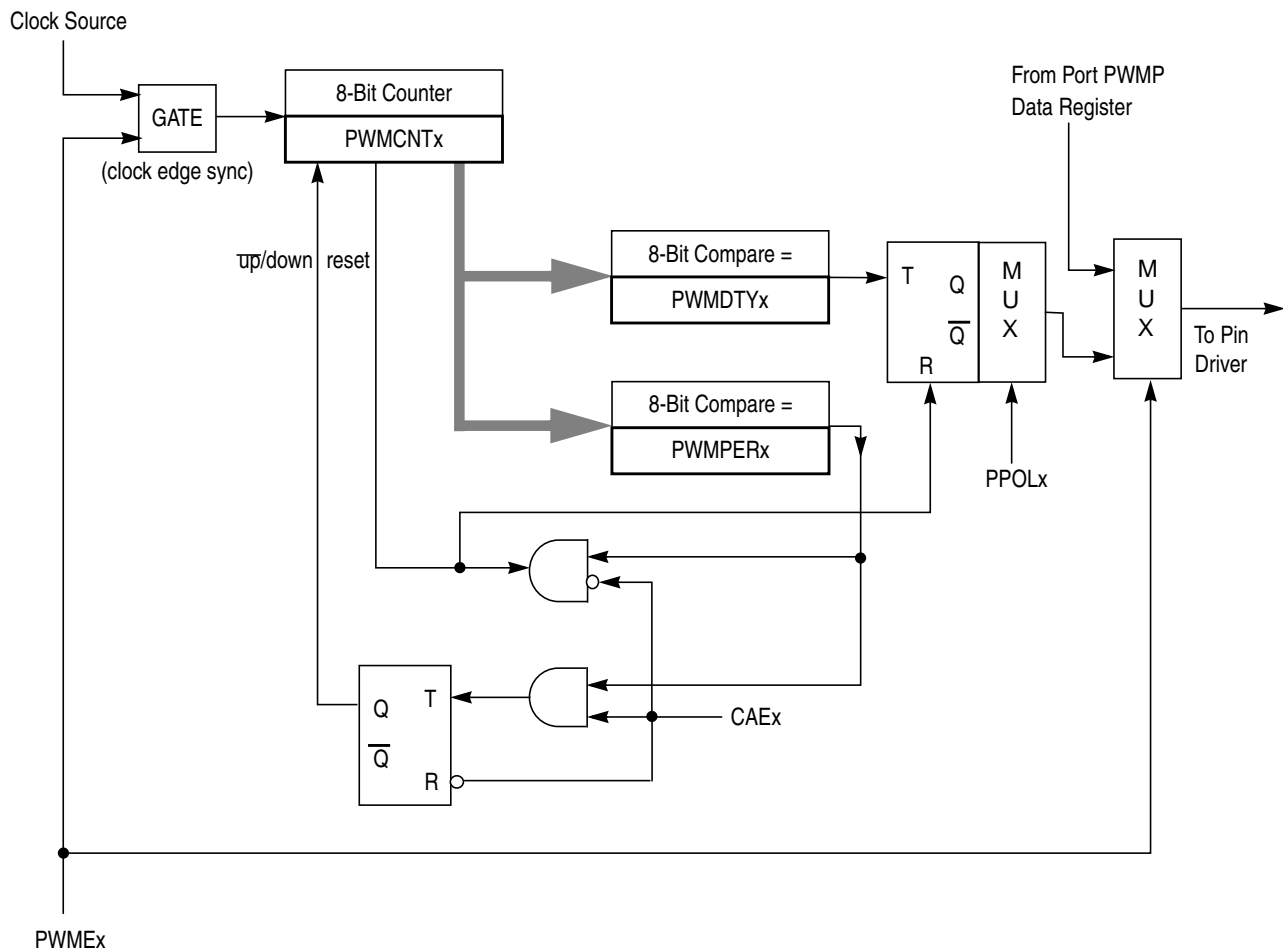

Figure 12-35. PWM Timer Channel Block Diagram

12.4.2.1 PWM Enable

Each PWM channel has an enable bit (PWME_x) to start its waveform output. When any of the PWME_x bits are set (PWME_x = 1), the associated PWM output signal is enabled immediately. However, the actual PWM waveform is not available on the associated PWM output until its clock source begins its next cycle due to the synchronization of PWME_x and the clock source. An exception to this is when channels are concatenated. Refer to [Section 12.4.2.7, “PWM 16-Bit Functions,”](#) for more detail.

NOTE

The first PWM cycle after enabling the channel can be irregular.

On the front end of the PWM timer, the clock is enabled to the PWM circuit by the PWME_x bit being high. There is an edge-synchronizing circuit to guarantee that the clock will only be enabled or disabled at an edge. When the channel is disabled (PWME_x = 0), the counter for the channel does not count.

12.4.2.2 PWM Polarity

Each channel has a polarity bit to allow starting a waveform cycle with a high or low signal. This is shown on the block diagram as a mux select of either the Q output or the \bar{Q} output of the PWM output flip-flop. When one of the bits in the PWMPOL register is set, the associated PWM channel output is high at the beginning of the waveform, then goes low when the duty count is reached. Conversely, if the polarity bit is 0, the output starts low and then goes high when the duty count is reached.

12.4.2.3 PWM Period and Duty

Dedicated period and duty registers exist for each channel and are double buffered so that if they change while the channel is enabled, the change will NOT take effect until one of the following occurs:

- The effective period ends
- The counter is written (counter resets to 0x0000)
- The channel is disabled

In this way, the output of the PWM will always be either the old waveform or the new waveform, not some variation in between. If the channel is not enabled, then writes to the period and duty registers will go directly to the latches as well as the buffer.

A change in duty or period can be forced into effect “immediately” by writing the new value to the duty and/or period registers and then writing to the counter. This forces the counter to reset and the new duty and/or period values to be latched. In addition, because the counter is readable it is possible to know where the count is with respect to the duty value and software can be used to make adjustments.

NOTE

When forcing a new period or duty into effect immediately, an irregular PWM cycle can occur.

Depending on the polarity bit, the duty registers will contain the count of either the high time or the low time.

12.4.2.4 PWM Timer Counters

Each channel has a dedicated 8-bit up/down counter which runs at the rate of the selected clock source (reference [Figure 12-34](#) for the available clock sources and rates). The counter compares to two registers, a duty register and a period register as shown in [Figure 12-35](#). When the PWM counter matches the duty register the output flip-flop changes state causing the PWM waveform to also change state. A match between the PWM counter and the period register behaves differently depending on what output mode is selected as shown in [Figure 12-35](#) and described in [Section 12.4.2.5, “Left Aligned Outputs,”](#) and [Section 12.4.2.6, “Center Aligned Outputs.”](#)

Each channel counter can be read at anytime without affecting the count or the operation of the PWM channel.

Any value written to the counter causes the counter to reset to 0x0000, the counter direction to be set to up, the immediate load of both duty and period registers with values from the buffers, and the output to change according to the polarity bit. When the channel is disabled ($PWME_x = 0$), the counter stops. When a channel becomes enabled ($PWME_x = 1$), the associated PWM counter continues from the count in the $PWMCNT_x$ register. This allows the waveform to resume when the channel is re-enabled. When the channel is disabled, writing 0 to the period register will cause the counter to reset on the next selected clock.

NOTE

If the user wants to start a new “clean” PWM waveform without any “history” from the old waveform, the user must write to channel counter ($PWMCNT_x$) prior to enabling the PWM channel ($PWME_x = 1$).

Generally, writes to the counter are done prior to enabling a channel to start from a known state. However, writing a counter can also be done while the PWM channel is enabled (counting). The effect is similar to writing the counter when the channel is disabled except that the new period is started immediately with the output set according to the polarity bit.

NOTE

Writing to the counter while the channel is enabled can cause an irregular PWM cycle to occur.

The counter is cleared at the end of the effective period (see [Section 12.4.2.5, “Left Aligned Outputs,”](#) and [Section 12.4.2.6, “Center Aligned Outputs,”](#) for more details).

Table 12-11. PWM Timer Counter Conditions

Counter Clears (0x0000)	Counter Counts	Counter Stops
When $PWMCNT_x$ register written to any value	When PWM channel is enabled ($PWME_x = 1$). Counts from last value in $PWMCNT_x$.	When PWM channel is disabled ($PWME_x = 0$)
Effective period ends		

12.4.2.5 Left Aligned Outputs

The PWM timer provides the choice of two types of outputs, left aligned or center aligned outputs. They are selected with the CAEx bits in the PWMCAE register. If the CAEx bit is cleared (CAEx = 0), the corresponding PWM output will be left aligned.

In left aligned output mode, the 8-bit counter is configured as an up counter only. It compares to two registers, a duty register and a period register as shown in the block diagram in Figure 12-35. When the PWM counter matches the duty register the output flip-flop changes state causing the PWM waveform to also change state. A match between the PWM counter and the period register resets the counter and the output flip-flop as shown in Figure 12-35 as well as performing a load from the double buffer period and duty register to the associated registers as described in Section 12.4.2.3, “PWM Period and Duty.” The counter counts from 0 to the value in the period register – 1.

NOTE

Changing the PWM output mode from left aligned output to center aligned output (or vice versa) while channels are operating can cause irregularities in the PWM output. It is recommended to program the output mode before enabling the PWM channel.

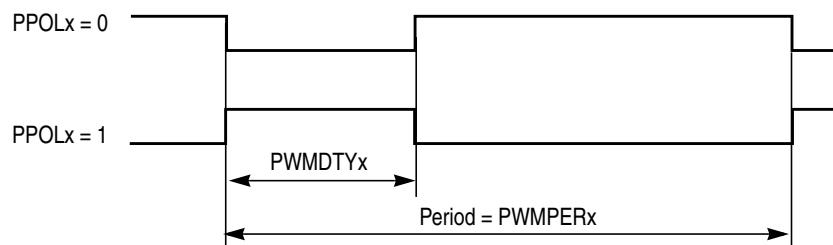

Figure 12-36. PWM Left Aligned Output Waveform

To calculate the output frequency in left aligned output mode for a particular channel, take the selected clock source frequency for the channel (A, B, SA, or SB) and divide it by the value in the period register for that channel.

- PWMx frequency = clock (A, B, SA, or SB) / PWMPERx
- PWMx duty cycle (high time as a% of period):
 - Polarity = 0 (PPOLx = 0)
Duty cycle = [(PWMPERx-PWMDTYx)/PWMPERx] * 100%
 - Polarity = 1 (PPOLx = 1)
Duty cycle = [PWMDTYx / PWMPERx] * 100%

As an example of a left aligned output, consider the following case:

Clock source = bus clock, where bus clock = 10 MHz (100 ns period)

PPOLx = 0

PWMPERx = 4

PWMDTYx = 1

PWMx frequency = 10 MHz/4 = 2.5 MHz

PWMx period = 400 ns

PWMx duty cycle = 3/4 * 100% = 75%

Shown below is the output waveform generated.

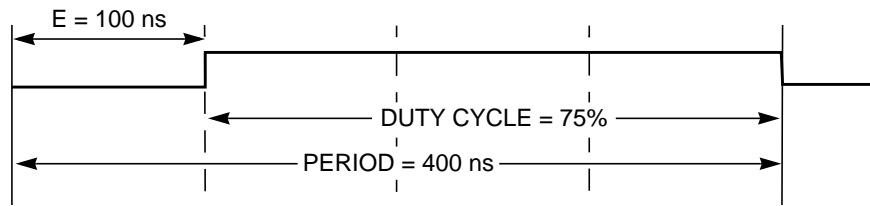

Figure 12-37. PWM Left Aligned Output Example Waveform

12.4.2.6 Center Aligned Outputs

For center aligned output mode selection, set the CAEx bit (CAEx = 1) in the PWMCAE register and the corresponding PWM output will be center aligned.

The 8-bit counter operates as an up/down counter in this mode and is set to up whenever the counter is equal to 0x0000. The counter compares to two registers, a duty register and a period register as shown in the block diagram in Figure 12-35. When the PWM counter matches the duty register the output flip-flop changes state causing the PWM waveform to also change state. A match between the PWM counter and the period register changes the counter direction from an up-count to a down-count. When the PWM counter decrements and matches the duty register again, the output flip-flop changes state causing the PWM output to also change state. When the PWM counter decrements and reaches 0, the counter direction changes from a down-count back to an up-count and a load from the double buffer period and duty registers to the associated registers is performed as described in Section 12.4.2.3, “PWM Period and Duty.” The counter counts from 0 up to the value in the period register and then back down to 0. Thus the effective period is $PWMPER_x * 2$.

NOTE

Changing the PWM output mode from left aligned output to center aligned output (or vice versa) while channels are operating can cause irregularities in the PWM output. It is recommended to program the output mode before enabling the PWM channel.

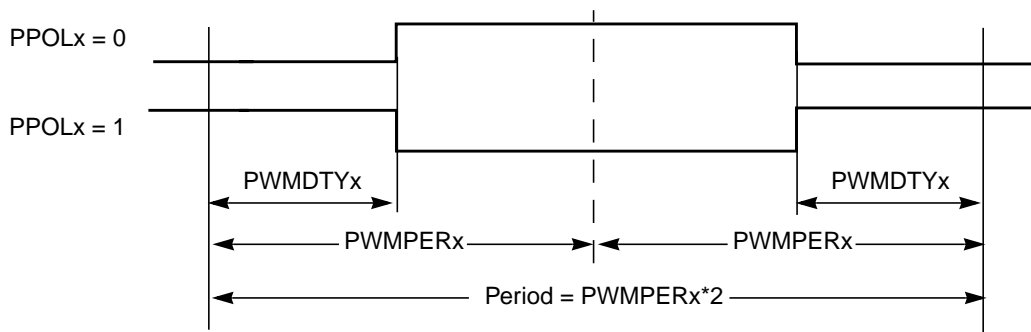

Figure 12-38. PWM Center Aligned Output Waveform

To calculate the output frequency in center aligned output mode for a particular channel, take the selected clock source frequency for the channel (A, B, SA, or SB) and divide it by twice the value in the period register for that channel.

- $PWMx \text{ frequency} = \text{clock (A, B, SA, or SB)} / (2 * PWMPERx)$
- PWMx duty cycle (high time as a% of period):
 - Polarity = 0 (PPOLx = 0)
 $Duty \text{ cycle} = [(PWMPERx - PWMDTYx) / PWMPERx] * 100\%$
 - Polarity = 1 (PPOLx = 1)
 $Duty \text{ cycle} = [PWMDTYx / PWMPERx] * 100\%$

As an example of a center aligned output, consider the following case:

Clock source = bus clock, where bus clock = 10 MHz (100 ns period)

PPOLx = 0

PWMPERx = 4

PWMDTYx = 1

PWMx frequency = $10 \text{ MHz} / 8 = 1.25 \text{ MHz}$

PWMx period = 800 ns

PWMx duty cycle = $3/4 * 100\% = 75\%$

Shown below is the output waveform generated.

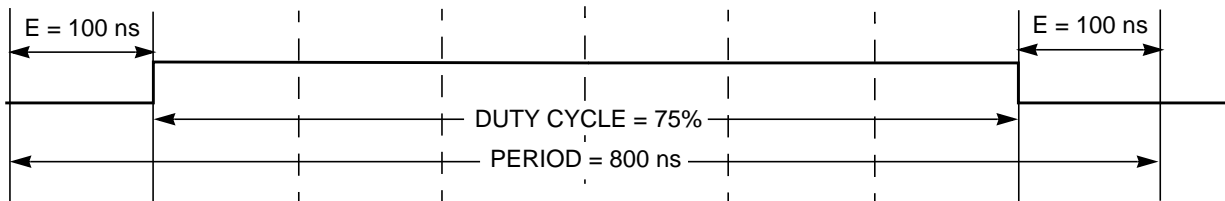

Figure 12-39. PWM Center Aligned Output Example Waveform

12.4.2.7 PWM 16-Bit Functions

The PWM timer also has the option of generating 6-channels of 8-bits or 3-channels of 16-bits for greater PWM resolution}. This 16-bit channel option is achieved through the concatenation of two 8-bit channels.

The PWMCTL register contains three control bits, each of which is used to concatenate a pair of PWM channels into one 16-bit channel. Channels 4 and 5 are concatenated with the CON45 bit, channels 2 and 3 are concatenated with the CON23 bit, and channels 0 and 1 are concatenated with the CON01 bit.

NOTE

Change these bits only when both corresponding channels are disabled.

When channels 4 and 5 are concatenated, channel 4 registers become the high-order bytes of the double byte channel as shown in Figure 12-40. Similarly, when channels 2 and 3 are concatenated, channel 2 registers become the high-order bytes of the double byte channel. When channels 0 and 1 are concatenated, channel 0 registers become the high-order bytes of the double byte channel.

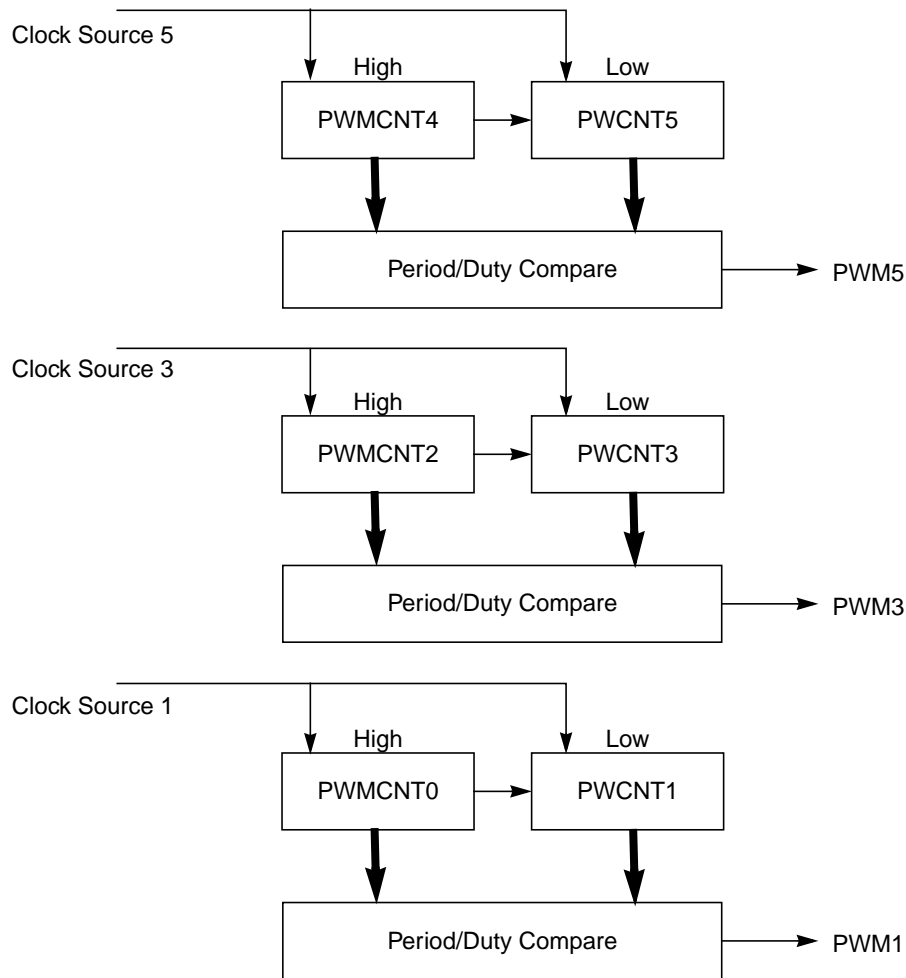

Figure 12-40. PWM 16-Bit Mode

When using the 16-bit concatenated mode, the clock source is determined by the low-order 8-bit channel clock select control bits. That is channel 5 when channels 4 and 5 are concatenated, channel 3 when channels 2 and 3 are concatenated, and channel 1 when channels 0 and 1 are concatenated. The resulting PWM is output to the pins of the corresponding low-order 8-bit channel as also shown in [Figure 12-40](#). The polarity of the resulting PWM output is controlled by the PPOLx bit of the corresponding low-order 8-bit channel as well.

After concatenated mode is enabled (CONxx bits set in PWMCTL register), enabling/disabling the corresponding 16-bit PWM channel is controlled by the low-order PWME_x bit. In this case, the high-order bytes PWME_x bits have no effect and their corresponding PWM output is disabled.

In concatenated mode, writes to the 16-bit counter by using a 16-bit access or writes to either the low or high-order byte of the counter will reset the 16-bit counter. Reads of the 16-bit counter must be made by 16-bit access to maintain data coherency.

Either left aligned or center aligned output mode can be used in concatenated mode and is controlled by the low-order CAEx bit. The high-order CAEx bit has no effect.

Table 12-12 is used to summarize which channels are used to set the various control bits when in 16-bit mode.

Table 12-12. 16-bit Concatenation Mode Summary

CONxx	PWMEx	PPOLx	PCLKx	CAEx	PWMx Output
CON45	PWME5	PPOL5	PCLK5	CAE5	PWM5
CON23	PWME3	PPOL3	PCLK3	CAE3	PWM3
CON01	PWME1	PPOL1	PCLK1	CAE1	PWM1

12.4.2.8 PWM Boundary Cases

Table 12-13 summarizes the boundary conditions for the PWM regardless of the output mode (left aligned or center aligned) and 8-bit (normal) or 16-bit (concatenation):

Table 12-13. PWM Boundary Cases

PWMDTYx	PWMPERx	PPOLx	PWMx Output
0x0000 (indicates no duty)	>0x0000	1	Always Low
0x0000 (indicates no duty)	>0x0000	0	Always High
XX	0x0000 ¹ (indicates no period)	1	Always High
XX	0x0000 ¹ (indicates no period)	0	Always Low
>= PWMPERx	XX	1	Always High
>= PWMPERx	XX	0	Always Low

¹ Counter = 0x0000 and does not count.

12.5 Resets

The reset state of each individual bit is listed within the register description section (see [Section 12.3, “Memory Map and Register Definition,”](#) which details the registers and their bit-fields. All special functions or modes which are initialized during or just following reset are described within this section.

- The 8-bit up/down counter is configured as an up counter out of reset.
- All the channels are disabled and all the counters don't count.

12.6 Interrupts

The PWM8B6CV1 module has only one interrupt which is generated at the time of emergency shutdown, if the corresponding enable bit (PWMIE) is set. This bit is the enable for the interrupt. The interrupt flag PWMIF is set whenever the input level of the PWM5 channel changes while PWM5ENA=1 or when PWMENA is being asserted while the level at PWM5 is active.

A description of the registers involved and affected due to this interrupt is explained in [Section 12.3.2.15, “PWM Shutdown Register \(PWMSDN\).”](#)

Chapter 13

Timer (S12TIM16B4CV1) Block Description

13.1 Introduction

The basic timer consists of a 16-bit, software-programmable counter driven by a seven-stage programmable prescaler.

This timer can be used for many purposes, including input waveform measurements while simultaneously generating an output waveform. Pulse widths can vary from microseconds to many seconds.

This timer contains 4 complete input capture/output compare channels [IOC 7:4] and one pulse accumulator. The input capture function is used to detect a selected transition edge and record the time. The output compare function is used for generating output signals or for timer software delays. The 16-bit pulse accumulator is used to operate as a simple event counter or a gated time accumulator. The pulse accumulator shares timer channel 7 pin when in event mode.

A full access for the counter registers or the input capture/output compare registers should take place in one clock cycle. Accessing high byte and low byte separately for all of these registers may not yield the same result as accessing them in one word.

13.1.1 Features

The S12TIM16B4C includes these distinctive features:

- Four input capture/output compare channels.
- Clock prescaling.
- 16-bit counter.
- 16-bit pulse accumulator.

13.1.2 Modes of Operation

STOP: Timer is off since clocks are stopped.

FREEZE: Timer counter keeps running, unless TSFRZ in TSCR (\$06) is set to one.

WAIT: Counters keeps running, unless TSWAI in TSCR (\$06) is set to one.

NORMAL: Timer counter keeps running, unless TEN in TSCR (\$06) is cleared.

13.1.3 Block Diagram

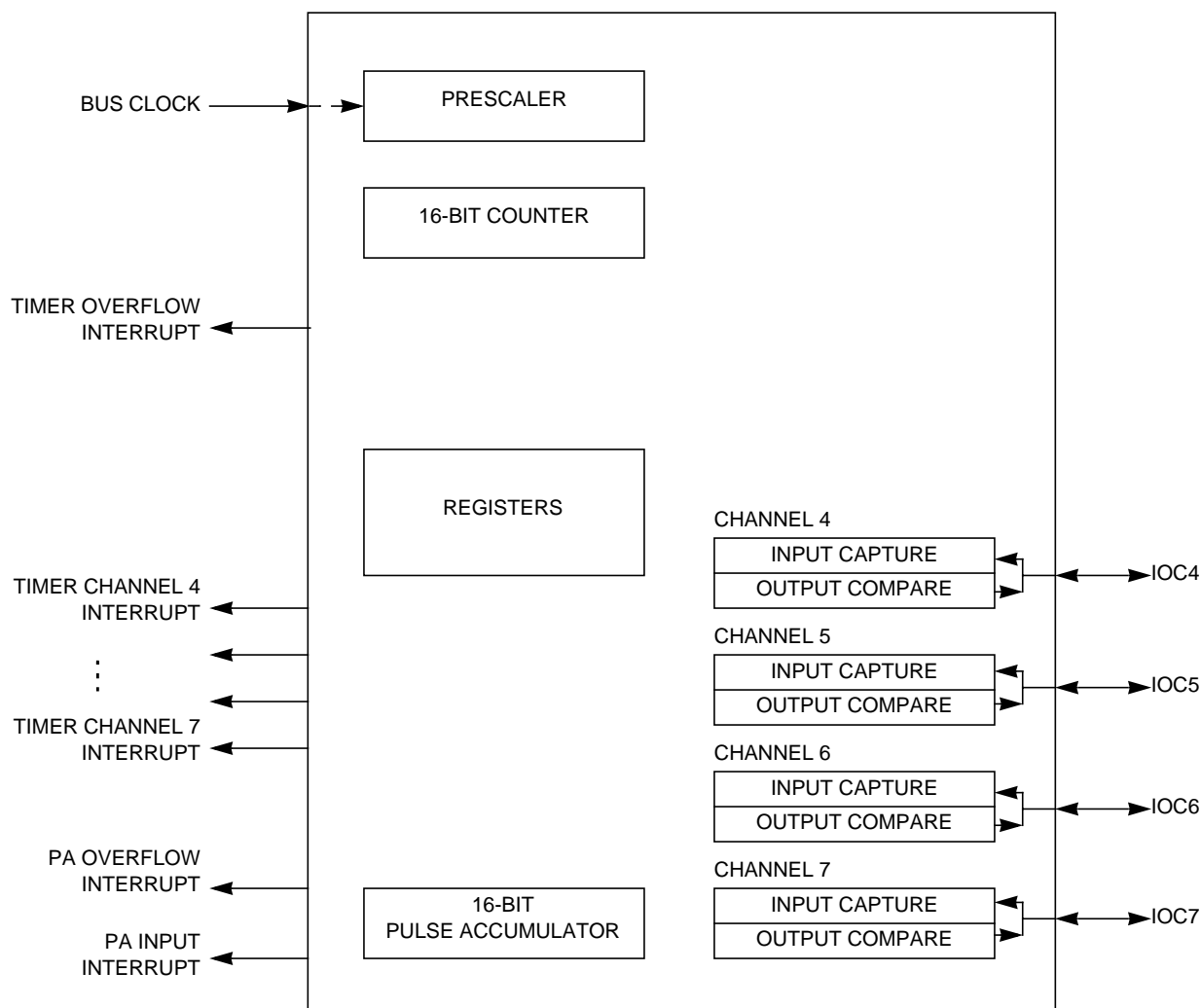

Figure 13-1. Timer Block Diagram

For more information see the respective functional descriptions in [Section 13.4, “Functional Description”](#) of this document.

13.2 Signal Description

The S12TIM16B4C module has a total four external pins.

13.2.1 Detailed Signal Descriptions

13.2.1.1 IOC7 — Input Capture and Output Compare Channel 7

This pin serves as input capture or output compare for channel 7. This pin can also be configured as pulse accumulator input.

13.2.1.2 IOC6 — Input Capture and Output Compare Channel 6

This pin serves as input capture or output compare for channel 6.

13.2.1.3 IOC5 — Input Capture and Output Compare Channel 5

This pin serves as input capture or output compare for channel 5.

13.2.1.4 IOC4 — Input Capture and Output Compare Channel 4

This pin serves as input capture or output compare for channel 4.

NOTE

For the description of interrupts see [Section 13.6, “Interrupts”](#).

13.3 Memory Map and Registers

13.3.1 Overview

This section provides a detailed description of all memory and registers.

13.3.2 Module Memory Map

A register summary for the S12TIM16B4C module is given below in [Figure 13-2](#). The address listed for each register is the address offset. The total address for each register is the sum of the base address for the S12TIM16B4C module and the address offset for each register.

Chapter 13 Timer (S12TIM16B4CV1) Block Description

Address	Name		Bit 7	6	5	4	3	2	1	Bit 0
0x0000	TIOS	R	IOS7	IOS6	IOS5	IOS4	0	0	0	0
		W								
0x0001	CFORC	R	0	0	0	0	0	0	0	0
		W	FOC7	FOC6	FOC5	FOC4				
0x0002	OC7M	R	OC7M7	OC7M6	OC7M5	OC7M4	0	0	0	0
		W								
0x0003	OC7D	R	OC7D7	OC7D6	OC7D5	OC7D4	0	0	0	0
		W								
0x0004	TCNT (High)	R	tcnt 15	tcnt 14	tcnt 13	tcnt 12	tcnt 11	tcnt 10	tcnt 9	tcnt 8
		W								
0x0005	TCNT (Low)	R	tcnt 7	tcnt 6	tcnt 5	tcnt 4	tcnt 3	tcnt 2	tcnt 1	tcnt 0
		W								
0x0006	TSCR1	R	TEN	TSWAI	TSFRZ	TFFCA	0	0	0	0
		W								
0x0007	TTOV	R	TOV7	TOV6	TOV5	TOV4	0	0	0	0
		W								
0x0008	TCTL1	R	OM7	OL7	OM6	OL6	OM5	OL5	OM4	OL4
		W								
0x0009	Reserved	R								
		W								
0x000A	TCTL3	R	EDG7B	EDG7A	EDG6B	EDG6A	EDG5B	EDG5A	EDG4B	EDG4A
		W								
0x000B	Reserved	R								
		W								
0x000C	TIE	R	C7I	C6I	C5I	C4I	0	0	0	0
		W								
0x000D	TSCR2	R	TOI	0	0	0	TCRE	PR2	PR1	PR0
		W								
0x000E	TFLG1	R	C7F	C6F	C5F	C4F	0	0	0	0
		W								
0x000F	TFLG2	R	TOF	0	0	0	0	0	0	0
		W								
0x0010 ↓ 0x0017	Reserved	R								
		W								
0x0018	TC4 (High)	R								
		W								
0x0019	TC4 (Low)	R								
		W								

= Unimplemented or Reserved

Figure 13-2. TIM16B4CV1 Register Summary (Sheet 1 of 2)

Address	Name		Bit 7	6	5	4	3	2	1	Bit 0
0x001A	TC5 (High)	R	tc5	tc5	tc5	tc5	tc5	tc5	tc5	tc5
		W	15	14	13	12	11	10	9	8
0x001B	TC5 (Low)	R	tc5	tc5	tc5	tc5	tc5	tc5	tc5	tc5
		W	7	6	5	4	3	2	1	0
0x001C	TC6 (High)	R	tc6	tc6	tc6	tc6	tc6	tc6	tc6	tc6
		W	15	14	13	12	11	10	9	8
0x001D	TC6(Low)	R	tc6	tc6	tc6	tc6	tc6	tc6	tc6	tc6
		W	7	6	5	4	3	2	1	0
0x001E	TC7 (High)	R	tc7	tc7	tc7	tc7	tc7	tc7	tc7	tc7
		W	15	14	13	12	11	10	9	8
0x001F	TC7 (Low)	R	tc7	tc7	tc7	tc7	tc7	tc7	tc7	tc7
		W	7	6	5	4	3	2	1	0
0x0020	PACTL	R	0	PAEN	PAMOD	PEDGE	CLK1	CLK0	PAOVI	PAI
		W								
0x0021	PAFLG	R	0	0	0	0	0	0	PAOVF	PAIF
		W								
0x0022	PACNT (High)	R	pacnt	pacnt	pacnt	pacnt	pacnt	pacnt	pacnt	pacnt
		W	15	14	13	12	11	10	9	8
0x0023	PACNT (Low)	R	pacnt	pacnt	pacnt	pacnt	pacnt	pacnt	pacnt	pacnt
		W	7	6	5	4	3	2	1	0
0x0024	Reserved	R								
0x002C		W								
0x002D	TIMTST	R	Timer Test Register							
		W								
0x002E	Reserved	R								
0x002F		W								

= Unimplemented or Reserved

Figure 13-2. TIM16B4CV1 Register Summary (Sheet 2 of 2)

13.3.3 Register Descriptions

This section consists of register descriptions in address order. Each description includes a standard register diagram with an associated figure number. Details of register bit and field function follow the register diagrams, in bit order.

13.3.3.1 Timer Input Capture/Output Compare Select (TIOS)

Module Base + 0x0000

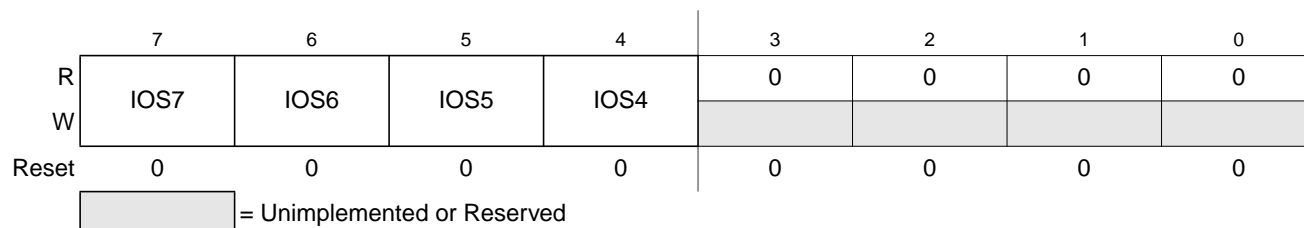

Figure 13-3. Timer Input Capture/Output Compare Select (TIOS)

Read or write anytime.

Table 13-1. TIOS Field Descriptions

Field	Description
7–4 IOS[7:4]	Input Capture or Output Compare Channel Configuration 0 The corresponding channel acts as an input capture. 1 The corresponding channel acts as an output compare.

13.3.3.2 Timer Compare Force Register (CFORC)

Module Base + 0x0001

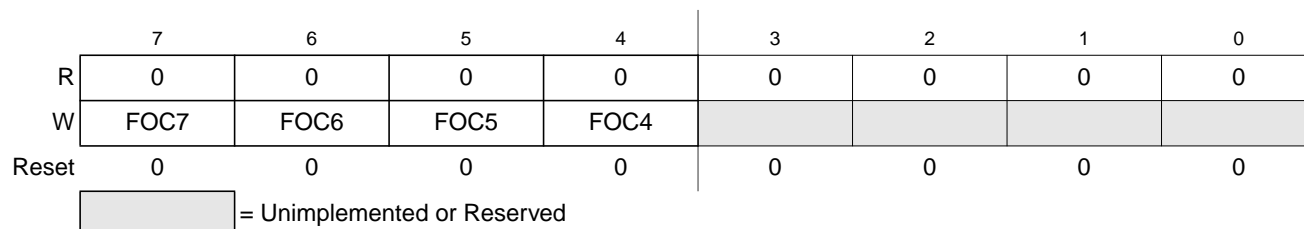

Figure 13-4. Timer Compare Force Register (CFORC)

Read anytime but will always return \$00. Write anytime.

Table 13-2. CFORC Field Descriptions

Field	Description
7–4 FOC[7:4]	Force Output Compare Action for Channel 7-4 — A write to this register with the corresponding (FOC 7:4) data bit(s) set causes the action programmed for output compare on channel “n” to occur immediately. The action taken is the same as if a successful comparison had just taken place with the TCn register except the interrupt flag does not get set. 0 Force Output Compare Action disabled 1 Force Output Compare Action enabled Note: A successful channel 7 output compare overrides any channel 6:4 compares. If forced output compare on any channel occurs at the same time as the successful output compare then forced output compare action will take precedence and interrupt flag will not get set.

13.3.3.3 Output Compare 7 Mask Register (OC7M)

Module Base + 0x0002

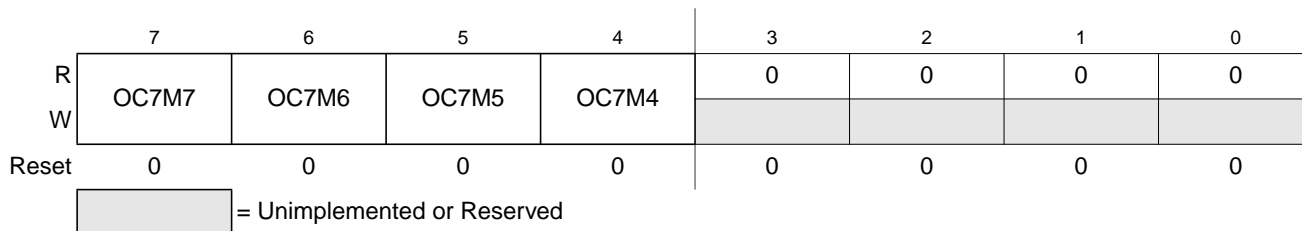

Figure 13-5. Output Compare 7 Mask Register (OC7M)

Read or write anytime.

Table 13-3. OC7M Field Descriptions

Field	Description
7–4 OC7M[7:4]	<p>Output Compare 7 Mask "n" Channel Bits — Setting the OC7Mn (n ranges from 4 to 6) will set the corresponding port to be an output port when the corresponding TIOSn (n ranges from 4 to 6) bit is set to be an output compare.</p> <p>0 Does not set the corresponding port to be an output port</p> <p>1 Sets the corresponding port to be an output port when this corresponding TIOS bit is set to be an output compare</p> <p>Note: A successful channel 7 output compare overrides any channel 6:4 compares. For each OC7M bit that is set, the output compare action reflects the corresponding OC7D bit.</p>

13.3.3.4 Output Compare 7 Data Register (OC7D)

Module Base + 0x0003

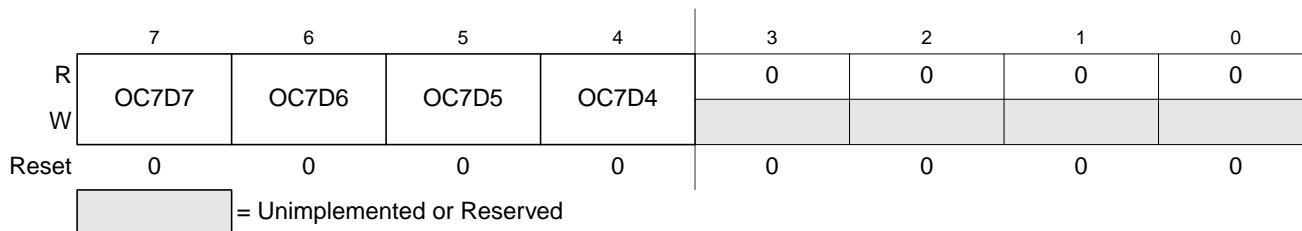

Figure 13-6. Output Compare 7 Data Register (OC7D)

Read or write anytime.

Table 13-4. OC7D Field Descriptions

Field	Description
7–4 OC7D[7:4]	<p>Output Compare 7 Data for Channel "n" — A channel 7 output compare will cause bits in the output compare 7 data register to transfer to the timer port data register if the corresponding output compare 7 mask register bits are set.</p>

13.3.3.5 Timer Count Register (TCNT)

Module Base + 0x0004–0x0005

	15	14	13	12	11	10	9	8	7	6	5	4	3	2	1	0
R	tcnt	tcnt	tcnt	tcnt	tcnt	tcnt	tcnt	tcnt	tcnt	tcnt	tcnt	tcnt	tcnt	tcnt	tcnt	tcnt
W	15	14	13	12	11	10	9	8	7	6	5	4	3	2	1	0
Reset	0	0	0	0	0	0	0	0	0	0	0	0	0	0	0	0

Figure 13-7. Timer Count Register (TCNT)

Read anytime. Writable only in special mode (refer for SOC guide for special modes).

The 16-bit main timer is an up counter. A full access for the counter register should take place in one clock cycle. A separate read/write for high byte and low byte will give a different result than accessing them as a word. The period of the first count after a write to the TCNT registers may be a different length because the write is not synchronized with the prescaler clock.

13.3.3.6 Timer System Control Register 1 (TSCR1)

Module Base + 0x0006

	7	6	5	4	3	2	1	0
R	TEN	TSWAI	TSFRZ	TFFCA	0	0	0	0
W								
Reset	0	0	0	0	0	0	0	0

= Unimplemented or Reserved

Figure 13-8. Timer System Control Register 1 (TSCR1)

Read or write anytime.

Table 13-5. TSCR1 Field Descriptions

Field	Description
7 TEN	Timer Enable — If for any reason the timer is not active, there is no divide by 64 clock for the pulse accumulator since the divide by 64 clock is generated by the timer prescaler. 0 Disables the timer. (Used for reducing power consumption). 1 Enables the timer.
6 TSWAI	Timer Module Stops While in Wait 0 Allows the timer and the pulse accumulator to continue running during the wait1 mode. 1 Disables the timer and pulse accumulator when the MCU is in the wait mode. Timer interrupts cannot be used to get the MCU out of wait mode.
5 TSFRZ	Timer Stops While in Freeze Mode — TSFRZ does not stop the pulse accumulator. 0 Allows the timer counter to continue running while in freeze mode. 1 Disables the timer counter whenever the MCU is in freeze mode. This is useful for emulation.

Table 13-5. TSCR1 Field Descriptions (continued)

Field	Description
4 TFFCA	<p>Timer Fast Flag Clear All</p> <p>0 Allows the timer flag clearing.</p> <p>1 For TFLG1 register, a read from an input capture or a write to the output compare channel [TC 7:4] causes the corresponding channel flag, CnF, to be cleared. For TFLG2 register, any access to the TCNT register clears the TOF flag. Any access to the PACNT registers clears the PAOVF and PAIF bits in the PAFLG register. This has the advantage of eliminating software overhead in a separate clear sequence. Extra care is required to avoid accidental flag clearing due to unintended accesses.</p>

13.3.3.7 Timer Toggle On Overflow Register 1 (TTOV)

Module Base + 0x0007

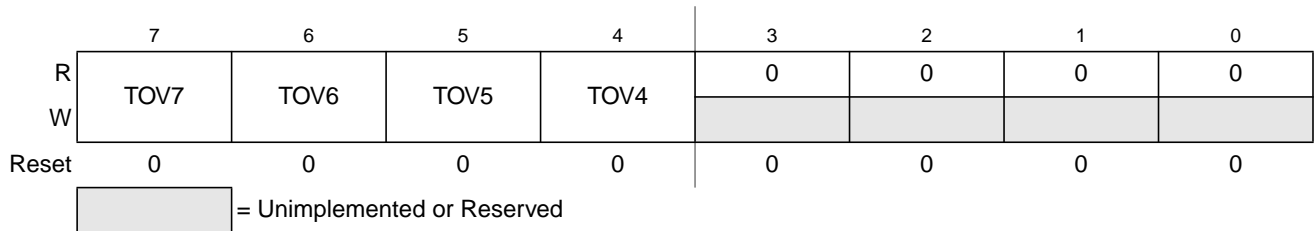

Figure 13-9. Timer Toggle On Overflow Register 1 (TTOV)

Read or write anytime.

Table 13-6. TTOV Field Descriptions

Field	Description
7-4 TOV[7:4]	<p>Toggle On Overflow Bits — TOVn toggles output compare pin on overflow. This feature only takes effect when the corresponding channel is configured for an output compare mode. When set, an overflow toggle on the output compare pin takes precedence over forced output compare but not channel 7 override events.</p> <p>0 Toggle output compare pin on overflow feature disabled.</p> <p>1 Toggle output compare pin on overflow feature enabled.</p>

13.3.3.8 Timer Control Register 1 (TCTL1)

Module Base + 0x0008

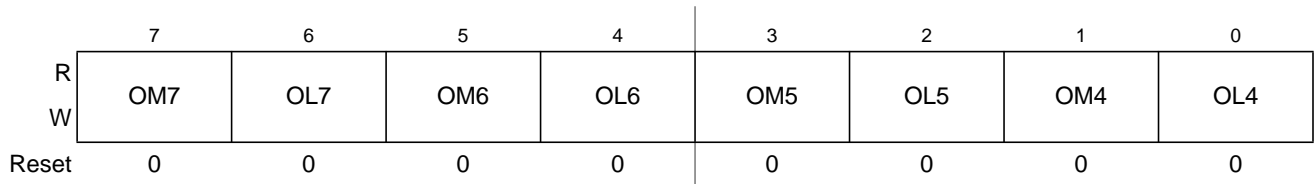

Figure 13-10. Timer Control Register 1 (TCTL1)

Read or write anytime.

Table 13-7. TCTL1 Field Descriptions

Field	Description
7, 5, 3, 1 OM[7:4] 6, 4, 3, 0 OL[7:4]	<p>OMn — Output Mode Bit OLn — Output Level Bit</p> <p>These four pairs of control bits are encoded to specify the output action to be taken as a result of a successful Output Compare on "n" channel. When either OMn or OLn is one, the pin associated with the corresponding channel becomes an output tied to its IOC. To enable output action by OMn and OLn bits on timer port, the corresponding bit in OC7M should be cleared.</p> <p>To operate the 16-bit pulse accumulator independently of input capture or output compare 7 and 4 respectively the user must set the corresponding bits IOSn = 1, OMn = 0, OLn = 0 and OC7M7 = 0</p> <p>See Table 13-8.</p> <p>To enable output action using the OM7 and OL7 bits on the timer port, the corresponding bit OC7M7 in the OC7M register must also be cleared. The settings for these bits can be seen in Table 13-9</p>

Table 13-8. Compare Result Output Action

OMn	OLn	Action
0	0	Timer disconnected from output pin logic
0	1	Toggle OCn output line
1	0	Clear OCn output line to zero
1	1	Set OCn output line to one

Table 13-9. The OC7 and OCx event priority

OC7M7=0				OC7M7=1			
OC7Mx=1		OC7Mx=0		OC7Mx=1		OC7Mx=0	
TC7=TCx	TC7>TCx	TC7=TCx	TC7>TCx	TC7=TCx	TC7>TCx	TC7=TCx	TC7>TCx
IOCx=OC7Dx IOC7=OM7/O L7	IOCx=OC7Dx +OMx/OLx IOC7=OM7/O L7	IOCx=OMx/OLx IOC7=OM7/OL7		IOCx=OC7Dx IOC7=OC7D7	IOCx=OC7Dx +OMx/OLx IOC7=OC7D7	IOCx=OMx/OLx IOC7=OC7D7	

Note: in [Table 13-9](#), the IOS7 and IOSx should be set to 1

IOSx is the register TIOS bit x,

OC7Mx is the register OC7M bit x,

TCx is timer Input Capture/Output Compare register,

IOCx is channel x,

OMx/OLx is the register TCTL1/TCTL2,

OC7Dx is the register OC7D bit x.

IOCx = OC7Dx + OMx/OLx, means that both OC7 event and OCx event will change channel x value.

13.3.3.9 Timer Control Register 3 (TCTL3)

Module Base + 0x000A

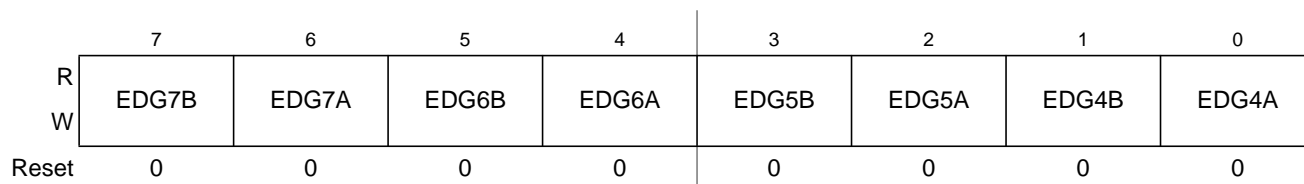

Figure 13-11. Timer Control Register 3 (TCTL3)

Read or write anytime.

Table 13-10. TCTL3 Field Descriptions

Field	Description
7, 5, 3, 1 EDG[7:4]B 6, 4, 2, 0 EDG[7:4]A	Input Capture Edge Control — These four pairs of control bits configure the input capture edge detector circuits. See Table 13-11.

Table 13-11. Edge Detector Circuit Configuration

EDGnB	EDGnA	Configuration
0	0	Capture disabled
0	1	Capture on rising edges only
1	0	Capture on falling edges only
1	1	Capture on any edge (rising or falling)

13.3.3.10 Timer Interrupt Enable Register (TIE)

Module Base + 0x000C

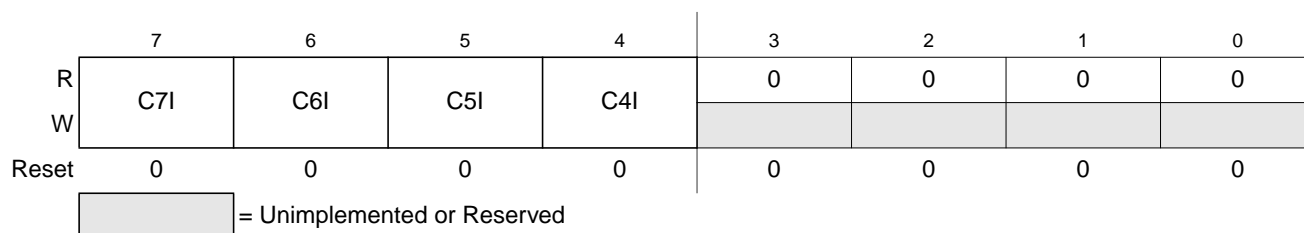

Figure 13-12. Timer Interrupt Enable Register (TIE)

Read or write anytime.

Table 13-12. TIE Field Descriptions

Field	Description
7–4 C[7:4]I	Input Capture/Output Compare Interrupt Enable. 0 Disables corresponding Interrupt flag (CnF of TFLG1 register) from causing a hardware interrupt 1 Enables corresponding Interrupt flag (CnF of TFLG1 register) to cause a hardware interrupt

13.3.3.11 Timer System Control Register 2 (TSCR2)

Module Base + 0x000D

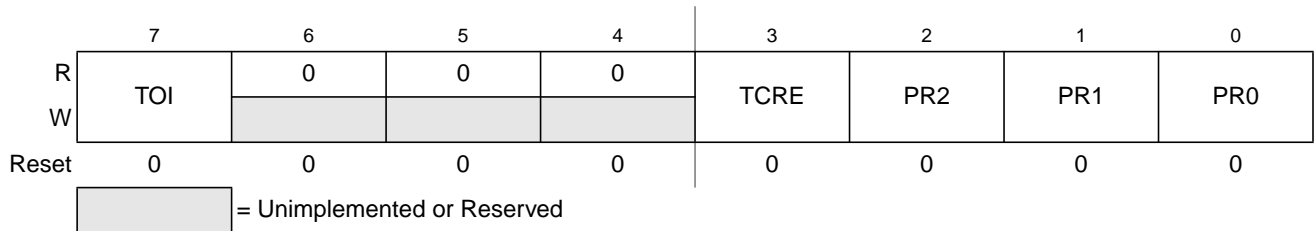
Figure 13-13. Timer System Control Register 2 (TSCR2)

Read or write anytime.

Table 13-13. TSCR2 Field Descriptions

Field	Description
7 TOI	Timer Overflow Interrupt Enable 0 Hardware Interrupt request inhibited. 1 Hardware interrupt requested when TOF flag set in TFLG2 register.
3 TCRE	Timer Counter Reset Enable — This mode of operation is similar to an up-counting modulus counter. If register TC7 = \$0000 and TCRE = 1, the timer counter register (TCNT) will stay at \$0000 continuously. If register TC7 = \$FFFF and TCRE = 1, TOF will not be set when the timer counter register (TCNT) is reset from \$FFFF to \$0000. TCRE=1 and TC7!=0,the TCNT cycle period will be TC7 x "prescaler counter width"+"1 Bus Clock",for a more detail explanation please refer to (1.4.4 Output Compare). 0 Inhibits Timer Counter reset and counter continues to run. 1 Enables Timer Counter reset by a successful output compare on channel 7
2–0 PR[2:0]	Timer Prescaler Select — These three bits select the frequency of the timer prescaler clock derived from the Bus Clock as shown in Table 13-14 . The newly selected prescale factor will not take effect until the next synchronized edge where all prescale counter stages equal zero.

Table 13-14. Timer Clock Selection

PR2	PR1	PR0	Timer Clock
0	0	0	Bus Clock / 1
0	0	1	Bus Clock / 2
0	1	0	Bus Clock / 4
0	1	1	Bus Clock / 8
1	0	0	Bus Clock / 16
1	0	1	Bus Clock / 32
1	1	0	Bus Clock / 64
1	1	1	Bus Clock / 128

13.3.3.12 Main Timer Interrupt Flag 1 (TFLG1)

Module Base + 0x000E

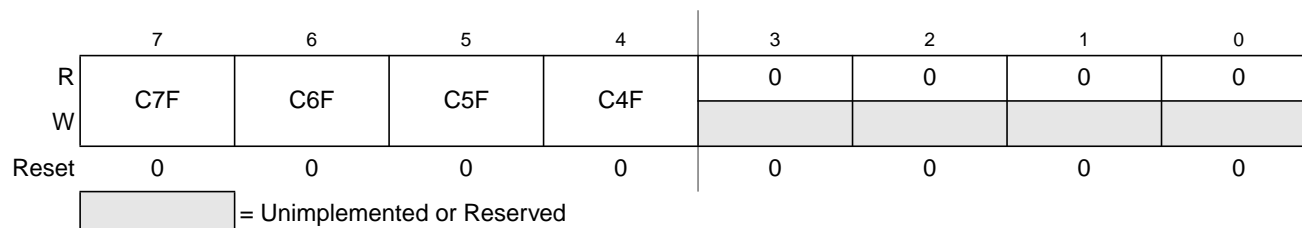

Figure 13-14. Main Timer Interrupt Flag 1 (TFLG1)

Read anytime.

Table 13-15. TFLG1 Field Descriptions

Field	Description
7-4 C[7:4]F	Input Capture/Output Compare Channel Flag — These flags are set when an input capture or output compare event occurs. Flag set on a particular channel is cleared by writing a one to that corresponding CnF bit. Writing a zero to CnF bit has no effect on its status. When TFFCA bit in TSCR register is set, a read from an input capture or a write into an output compare channel will cause the corresponding channel flag CnF to be cleared. 0 No event (Input Capture or Output Compare event) occurred. 1 Input Capture or Output Compare event occurred

13.3.3.13 Main Timer Interrupt Flag 2 (TFLG2)

Module Base + 0x000F

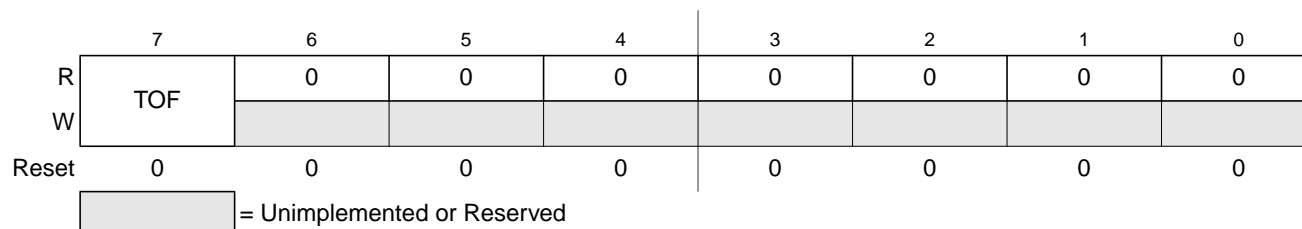

Figure 13-15. Main Timer Interrupt Flag 2 (TFLG2)

Read anytime.

Table 13-16. TFLG2 Field Descriptions

Field	Description
7 TOF	Timer Overflow Flag — The TFLG2 register indicates when an interrupt has occurred. Writing a one to the TOF bit will clear it. Any access to TCNT will clear TOF bit of TFLG2 register if the TFFCA bit in TSCR register is set. 0 Flag indicates an Interrupt has not occurred. 1 Flag indicates that an Interrupt has occurred (Set when 16-bit free-running timer counter overflows from \$FFFF to \$0000)

13.3.3.14 Timer Input Capture/Output Compare Registers (TC4–TC7)

TC4 Module Base + 0x0018–0x0019

	15	14	13	12	11	10	9	8	7	6	5	4	3	2	1	0
R	tc4	tc4	tc4	tc4	tc4	tc4	tc4	tc4	tc4	tc4	tc4	tc4	tc4	tc4	tc4	tc4
W	15	14	13	12	11	10	9	8	7	6	5	4	3	2	1	0
Reset	0	0	0	0	0	0	0	0	0	0	0	0	0	0	0	0

TC5 Module Base + 0x001A–0x001B

	15	14	13	12	11	10	9	8	7	6	5	4	3	2	1	0
R	tc5	tc5	tc5	tc5	tc5	tc5	tc5	tc5	tc5	tc5	tc5	tc5	tc5	tc5	tc5	tc5
W	15	14	13	12	11	10	9	8	7	6	5	4	3	2	1	0
Reset	0	0	0	0	0	0	0	0	0	0	0	0	0	0	0	0

TC6 Module Base + 0x001C–0x001D

	15	14	13	12	11	10	9	8	7	6	5	4	3	2	1	0
R	tc6	tc6	tc6	tc6	tc6	tc6	tc6	tc6	tc6	tc6	tc6	tc6	tc6	tc6	tc6	tc6
W	15	14	13	12	11	10	9	8	7	6	5	4	3	2	1	0
Reset	0	0	0	0	0	0	0	0	0	0	0	0	0	0	0	0

TC7 Module Base + 0x001E–0x001F

	15	14	13	12	11	10	9	8	7	6	5	4	3	2	1	0
R	tc7	tc7	tc7	tc7	tc7	tc7	tc7	tc7	tc7	tc7	tc7	tc7	tc7	tc7	tc7	tc7
W	15	14	13	12	11	10	9	8	7	6	5	4	3	2	1	0
Reset	0	0	0	0	0	0	0	0	0	0	0	0	0	0	0	0

Figure 13-16. Timer Input Capture/Output Compare Registers (TC4–TC7)

Read anytime. Write anytime for output compare function. Writes to these registers have no effect during input capture.

Depending on the TIOS bit for the corresponding channel, these registers are used to latch the value of the free-running counter when a defined transition is sensed by the corresponding input capture edge detector or to trigger an output action for output compare.

NOTE

Read/Write access in byte mode for high byte should take place before low byte otherwise it will give a different result.

13.3.3.15 16-Bit Pulse Accumulator Control Register (PACTL)

Module Base + 0x0020

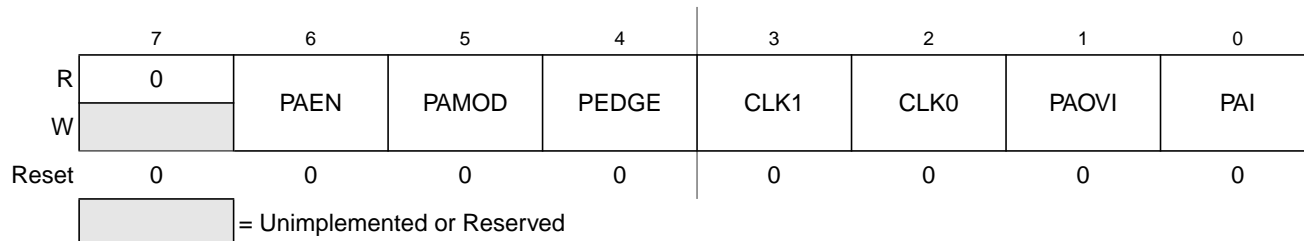

Figure 13-17. 16-Bit Pulse Accumulator Control Register (PACTL)

Read: any time

Write: any time

Table 13-17. PACTL Field Descriptions

Field	Description
6 PAEN	Pulse Accumulator System Enable — PAEN is independent from TEN. With timer disabled, the pulse accumulator can still function unless pulse accumulator is disabled. When PAEN is set, the PACT is enabled. The PACT shares the input pin with IOC7. 0 Pulse Accumulator system disabled 1 Pulse Accumulator system enabled
5 PAMOD	Pulse Accumulator Mode — This bit is active only when the Pulse Accumulator is enabled (PAEN = 1). See Table 13-18 . 0 Event counter mode 1 Gated time accumulation mode
4 PEDGE	Pulse Accumulator Edge Control — This bit is active only when the Pulse Accumulator is enabled (PAEN = 1). For PAMOD bit = 0 (event counter mode). 0 Falling edges on IOC7 pin cause the count to be incremented. 1 Rising edges on IOC7 pin cause the count to be incremented. For PAMOD bit = 1 (gated time accumulation mode). 0 IOC7 input pin high enables M (bus clock) divided by 64 clock to Pulse Accumulator and the trailing falling edge on IOC7 sets the PAIF flag. 1 IOC7 input pin low enables M (bus clock) divided by 64 clock to Pulse Accumulator and the trailing rising edge on IOC7 sets the PAIF flag. If the timer is not active (TEN = 0 in TSCR), there is no divide-by-64 since the divide by 64 clock is generated by the timer prescaler. See Table 13-18 .
3–2 CLK[1:0]	Clock Select Bits — For the description of PACTL please refer to Figure 13-22 . If the pulse accumulator is disabled (PAEN = 0), the prescaler clock from the timer is always used as an input clock to the timer counter. The change from one selected clock to the other happens immediately after these bits are written. See Table 13-19 .
1 PAOVI	Pulse Accumulator Overflow Interrupt Enable 0 Interrupt inhibited. 1 Interrupt requested if PAOVF bit of PFLG register is set.
0 PAI	Pulse Accumulator Input Interrupt Enable 0 Interrupt inhibited. 1 Interrupt requested if PAIF bit of PAFLG register is set.

Table 13-18. Pin Action

PAMOD	PEDGE	Pin Action
0	0	Falling edge
0	1	Rising edge
1	0	Divide by 64 clock enabled with pin high level
1	1	Divide by 64 clock enabled with pin low level

Table 13-19. Timer Clock Selection

CLK1	CLK0	Timer Clock
0	0	Use timer prescaler clock as timer counter clock
0	1	Use PCLK as input to timer counter clock
1	0	Use PCLK/256 as timer counter clock frequency
1	1	Use PCLK/65536 as timer counter clock frequency

13.3.3.16 Pulse Accumulator Flag Register (PAFLG)

Module Base + 0x0021

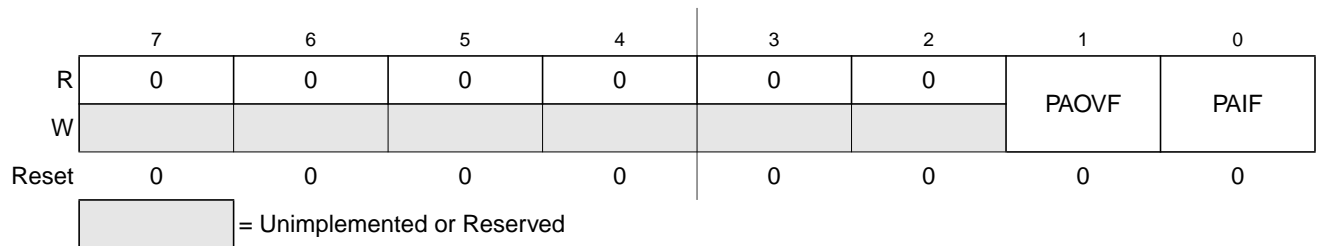

Figure 13-18. Pulse Accumulator Flag Register (PAFLG)

Read or write anytime.

Table 13-20. PAFLG Field Descriptions

Field	Description
1 PAOVF	Pulse Accumulator Overflow Flag — Writing a one to this bit clears it, writing a zero has not effect. 0 Flag indicates that there is no overflow condition of pulse accumulator counter. 1 Flag indicates overflow condition of pulse accumulator counter from \$FFFF to \$0000.
0 PAIF	Pulse Accumulator Input Edge Flag — In event mode the event edge triggers PAIF and in gated time accumulation mode the trailing edge of the gate signal at the IOC7 input pin triggers PAIF. Writing a one to this bit clears it, writing a zero has not effect. Any access to the PACNT register will clear all the flags in this register when TFFCA bit of TSCR register is set. 0 Flag indicates that no selected edge has been detected on the IOC7 input pin. 1 Flag indicates that the selected edge is detected on the IOC7 input pin.

13.3.3.17 Pulse Accumulators Count Registers (PACNT)

Module Base + 0x0022–0x0023

	15	14	13	12	11	10	9	8	7	6	5	4	3	2	1	0
R	pacnt	pacnt	pacnt	pacnt	pacnt	pacnt	pacnt	pacnt	pacnt	pacnt	pacnt	pacnt	pacnt	pacnt	pacnt	pacnt
W	15	14	13	12	11	10	9	8	7	6	5	4	3	2	1	0
Reset	0	0	0	0	0	0	0	0	0	0	0	0	0	0	0	0

Figure 13-19. Pulse Accumulators Count Registers (PACNT)

Read or write any time.

When PACNT overflows from \$FFFF to \$0000, the PAOVF bit of PAFLG register is set.

These registers contain the number of active input edges on TOC7 input pin since the last reset. Full count register access should take place in one clock cycle. A separate read/write for high byte and low byte will give a different result than accessing them as a word.

NOTE

Reading the pulse accumulator counter registers immediately after an active edge on the pulse accumulator input pin may miss the last count since the input has to be synchronized with the bus clock first.

13.4 Functional Description

13.4.1 General

This section provides a complete functional description of the timer S12TIM16B4C block. Please refer to the detailed timer block diagram in [Figure 13-20](#) as necessary.

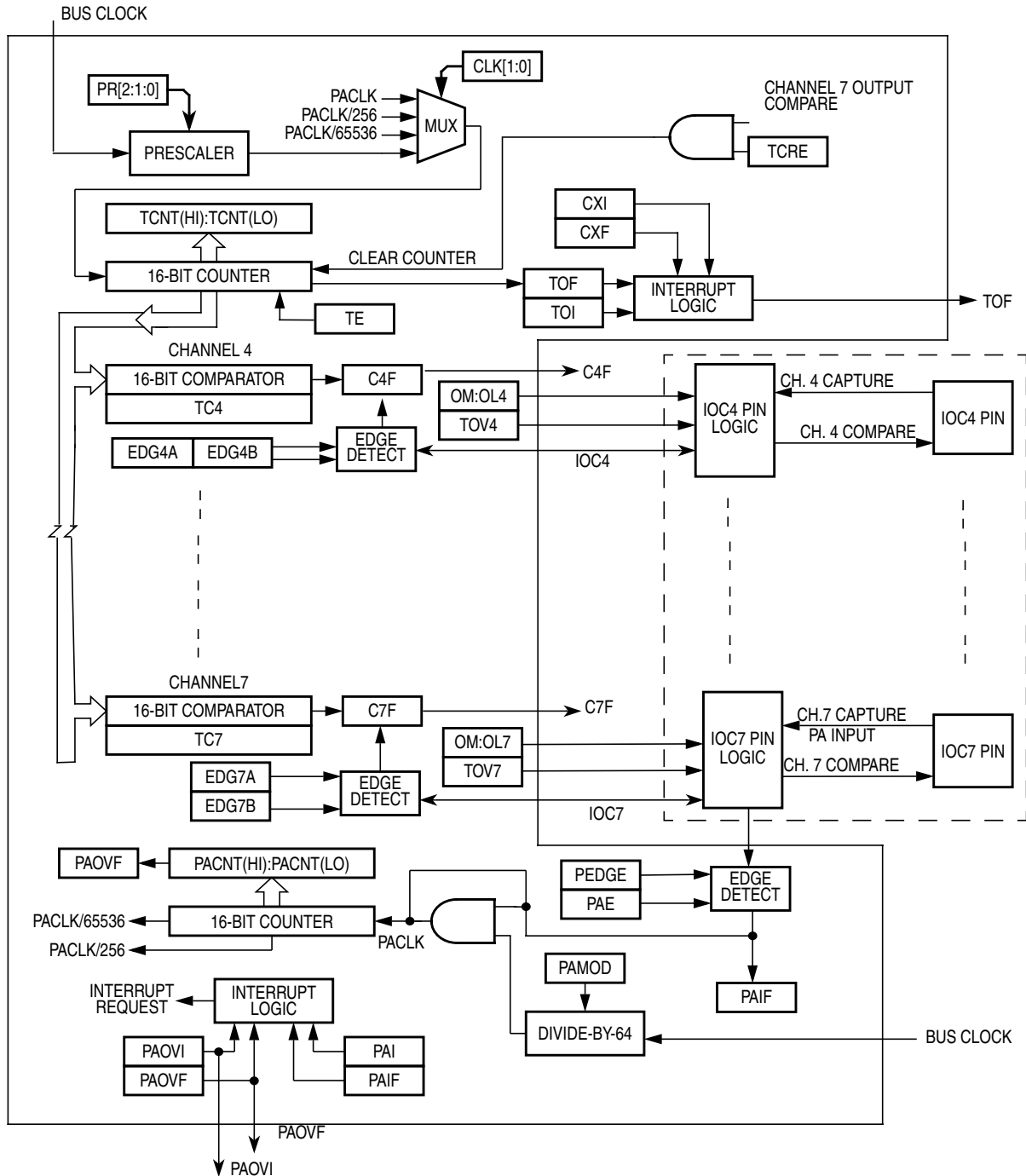

Figure 13-20. Detailed Timer Block Diagram

13.4.2 Prescaler

The prescaler divides the bus clock by 1, 2, 4, 8, 16, 32, 64, or 128. The prescaler select bits, PR[2:0], select the prescaler divisor. PR[2:0] are in timer system control register 2 (TSCR2).

13.4.3 Input Capture

Clearing the I/O (input/output) select bit, IOS_n, configures channel n as an input capture channel. The input capture function captures the time at which an external event occurs. When an active edge occurs on the pin of an input capture channel, the timer transfers the value in the timer counter into the timer channel registers, TC_n.

The minimum pulse width for the input capture input is greater than two bus clocks.

An input capture on channel n sets the CnF flag. The CnI bit enables the CnF flag to generate interrupt requests.

13.4.4 Output Compare

Setting the I/O select bit, IOS_n, configures channel n as an output compare channel. The output compare function can generate a periodic pulse with a programmable polarity, duration, and frequency. When the timer counter reaches the value in the channel registers of an output compare channel, the timer can set, clear, or toggle the channel pin. An output compare on channel n sets the CnF flag. The CnI bit enables the CnF flag to generate interrupt requests.

The output mode and level bits, OM_n and OL_n, select set, clear, toggle on output compare. Clearing both OM_n and OL_n disconnects the pin from the output logic.

Setting a force output compare bit, FOC_n, causes an output compare on channel n. A forced output compare does not set the channel flag.

A successful output compare on channel 7 overrides output compares on all other output compare channels. The output compare 7 mask register masks the bits in the output compare 7 data register. The timer counter reset enable bit, TC_{CRE}, enables channel 7 output compares to reset the timer counter. A channel 7 output compare can reset the timer counter even if the IOC₇ pin is being used as the pulse accumulator input.

Writing to the timer port bit of an output compare pin does not affect the pin state. The value written is stored in an internal latch. When the pin becomes available for general-purpose output, the last value written to the bit appears at the pin.

When TC_{CRE} is set and TC₇ is not equal to 0, then TC_{NT} will cycle from 0 to TC₇. When TC_{NT} reaches TC₇ value, it will last only one bus cycle then reset to 0.

Note: in [Figure 13-21](#), if PR[2:0] is equal to 0, one prescaler counter equal to one bus clock

Figure 13-21. The TCNT cycle diagram under TC_{CRE}=1 condition

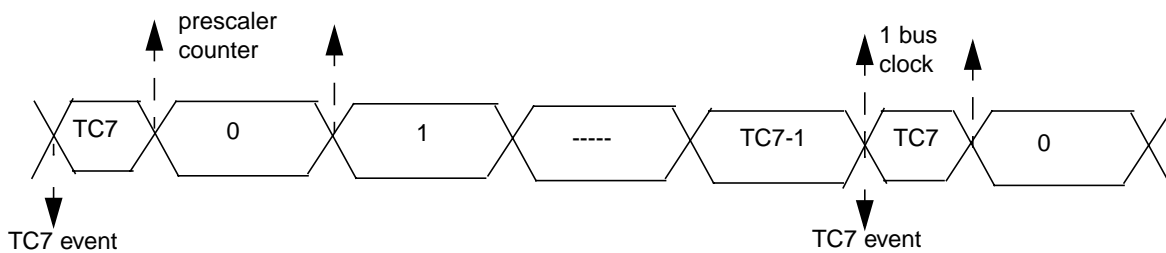

13.4.5 Pulse Accumulator

The pulse accumulator (PACNT) is a 16-bit counter that can operate in two modes:

- Event counter mode — Counting edges of selected polarity on the pulse accumulator input pin, IOC7.
- Gated time accumulation mode — Counting pulses from a divide-by-64 clock. The PAMOD bit selects the mode of operation.

The minimum pulse width for the PAI input is greater than two bus clocks. The maximum input frequency on the pulse accumulator channel is one half the bus frequency or Eclk.

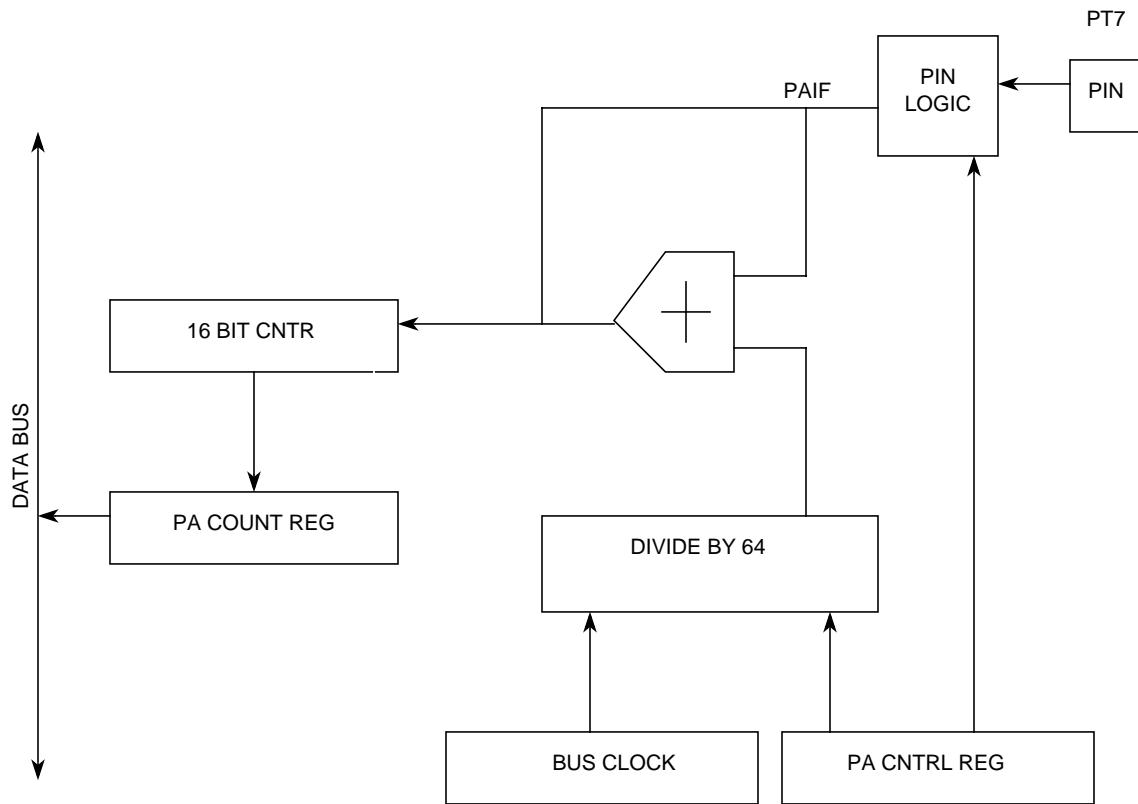

Figure 13-22. Pulse Accumulator System Block Diagram

13.4.5.1 Event Counter Mode

Clearing the PAMOD bit configures the PACNT for event counter operation. An active edge on the IOC7 pin increments the pulse accumulator counter. The PEDGE bit selects falling edges or rising edges to increment the count.

NOTE

The PACNT input and timer channel 7 use the same pin IOC7. To use the IOC7, disconnect it from the output logic by clearing the channel 7 output mode and output level bits, OM7 and OL7. Also clear the channel 7 output compare 7 mask bit, OC7M7.

The Pulse Accumulator counter register reflect the number of active input edges on the PACNT input pin, IOC7 since the last reset.

The PAOVF bit is set when the accumulator rolls over from \$FFFF to \$0000. The pulse accumulator overflow interrupt enable bit, PAOVI, enables the PAOVF flag to generate interrupt requests.

NOTE

The pulse accumulator counter can operate in event counter mode even when the timer enable bit, TEN, is clear.

13.4.5.2 Gated Time Accumulation Mode

Setting the PAMOD bit configures the pulse accumulator for gated time accumulation operation. An active level on the PACNT input pin enables a divided-by-64 clock to drive the pulse accumulator. The PEDGE bit selects low levels or high levels to enable the divided-by-64 clock.

The trailing edge of the active level at the IOC7 pin sets the PAIF. The PAI bit enables the PAIF flag to generate interrupt requests.

The pulse accumulator counter register reflect the number of pulses from the divided-by-64 clock since the last reset.

NOTE

The timer prescaler generates the divided-by-64 clock. If the timer is not active, there is no divided-by-64 clock.

13.5 Resets

13.5.1 General

The reset state of each individual bit is listed within the Register Description section (see [Section 13.3, “Memory Map and Registers”](#)) which details the registers and their bit-fields.

13.6 Interrupts

13.6.1 General

This section describes interrupts originated by the S12TIM16B4C block. [Table 13-21](#) lists the interrupts generated by the S12TIM16B4C to communicate with the MCU.

Table 13-21. S12TIM16B4C Interrupts

Interrupt	Offset ¹	Vector ¹	Priority ¹	Source	Description
C[7:4]F	—	—	—	Timer Channel 7-4	Active high timer channel interrupts 7-4
PAOVI	—	—	—	Pulse Accumulator Input	Active high pulse accumulator input interrupt
PAOVF	—	—	—	Pulse Accumulator Overflow	Pulse accumulator overflow interrupt
TOF	—	—	—	Timer Overflow	Timer Overflow interrupt

¹ Refer to the SoC Guide for information regarding offset, vector and priority.

13.6.2 Description of Interrupt Operation

The S12TIM16B4C uses a total of 7 interrupt vectors. The interrupt vector offsets and interrupt numbers are chip dependent. More information on interrupt vector offsets and interrupt numbers can be found in the System on Chip Guide.

13.6.2.1 Channel [7:4] Interrupt

These active high outputs is asserted by the module to request a timer channel 7 – 4 interrupt following an input capture or output compare event on these channels [7-4]. For the interrupt to be asserted on a specific channel, the enable, CnI bit of TIE register should be set. These interrupts are serviced by the system controller.

13.6.2.2 Pulse Accumulator Input Interrupt

This active high output is asserted by the module to request a timer pulse accumulator input interrupt following the configured event on IOC7 input pin (in either modes, event mode and time accumulation mode) when pulse accumulator input interrupt enable, PAI bit in PACTL register is set. This interrupt is serviced by the system controller.

NOTE

For more information about event mode operation and gated time accumulation operation of the timers refer to [Section 13.4, “Functional Description”](#). Further details can be found in creation guide of this module.

13.6.2.3 Pulse Accumulator Overflow Interrupt

This active high output will be asserted by the module to request a timer pulse accumulator overflow interrupt, following the timer pulse accumulator counter overflow, when the pulse accumulator overflow enable bit, PAOVI of PACTL register is set. This interrupt is serviced by the system controller.

NOTE

For more information about event mode operation and gated time accumulation operation of the timers refer to [Section 13.4, “Functional Description”](#). Further details can be found in creation guide of this module.

13.6.2.4 Timer Overflow Interrupt (TOF)

This active high output will be asserted by the module to request a timer overflow interrupt, following the timer counter overflow when the overflow enable bit (TOI) bit of TFLG2 register is set. This interrupt is serviced by the system controller.

Chapter 14

Dual Output Voltage Regulator (VREG3V3V2)

Block Description

14.1 Introduction

The VREG3V3V2 is a dual output voltage regulator providing two separate 2.5 V (typical) supplies differing in the amount of current that can be sourced. The regulator input voltage range is from 3.3 V up to 5 V (typical).

14.1.1 Features

The block VREG3V3V2 includes these distinctive features:

- Two parallel, linear voltage regulators
 - Bandgap reference
- Low-voltage detect (LVD) with low-voltage interrupt (LVI)
- Power-on reset (POR)
- Low-voltage reset (LVR)

14.1.2 Modes of Operation

There are three modes VREG3V3V2 can operate in:

- Full-performance mode (FPM) (MCU is not in stop mode)

The regulator is active, providing the nominal supply voltage of 2.5 V with full current sourcing capability at both outputs. Features LVD (low-voltage detect), LVR (low-voltage reset), and POR (power-on reset) are available.
- Reduced-power mode (RPM) (MCU is in stop mode)

The purpose is to reduce power consumption of the device. The output voltage may degrade to a lower value than in full-performance mode, additionally the current sourcing capability is substantially reduced. Only the POR is available in this mode, LVD and LVR are disabled.
- Shutdown mode

Controlled by V_{REGEN} (see device overview chapter for connectivity of V_{REGEN}).

This mode is characterized by minimum power consumption. The regulator outputs are in a high impedance state, only the POR feature is available, LVD and LVR are disabled.

This mode must be used to disable the chip internal regulator VREG3V3V2, i.e., to bypass the VREG3V3V2 to use external supplies.

14.1.3 Block Diagram

Figure 14-1 shows the function principle of VREG3V3V2 by means of a block diagram. The regulator core REG consists of two parallel sub-blocks, REG1 and REG2, providing two independent output voltages.

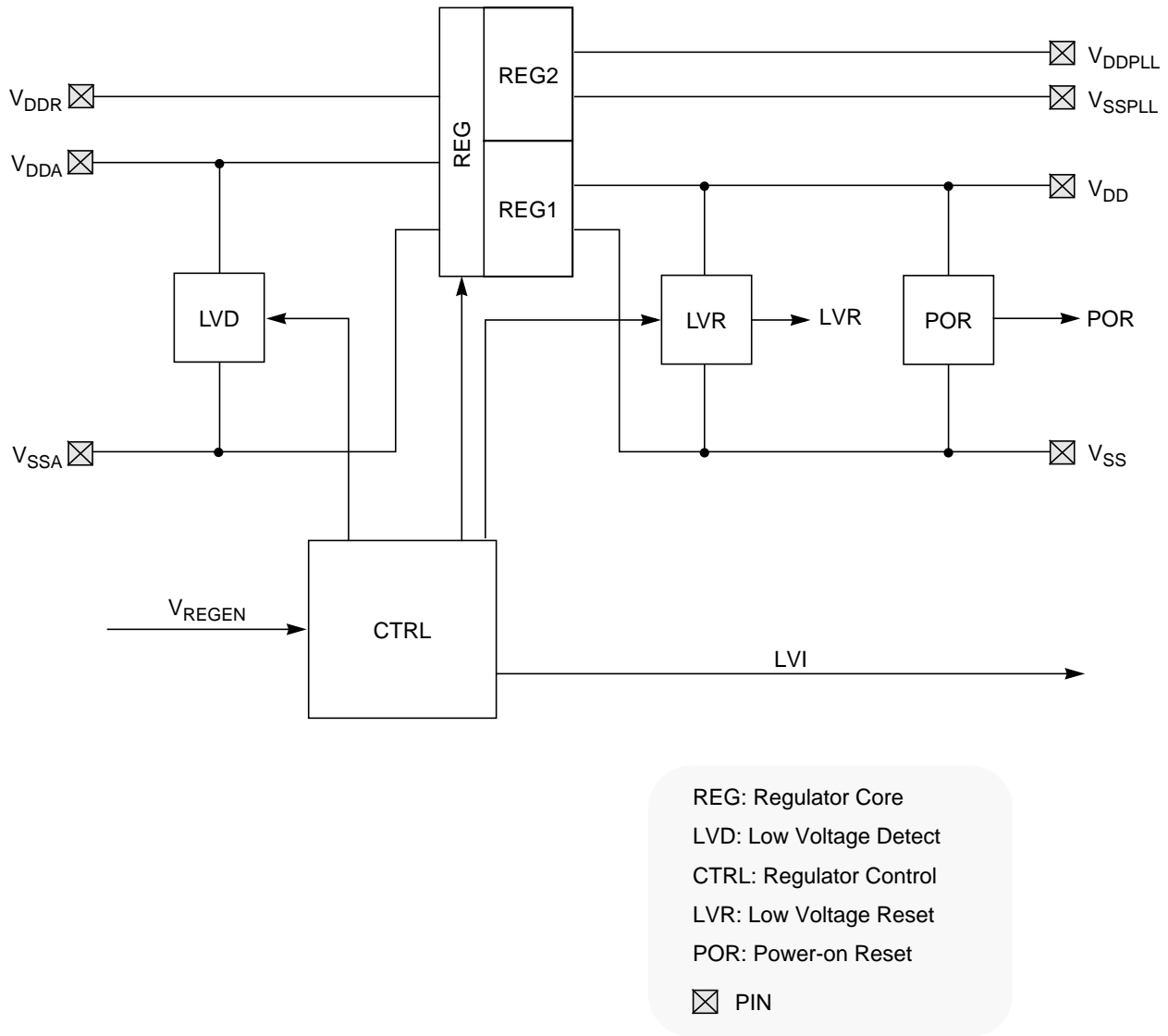

Figure 14-1. VREG3V3 Block Diagram

14.2 External Signal Description

Due to the nature of VREG3V3V2 being a voltage regulator providing the chip internal power supply voltages most signals are power supply signals connected to pads.

Table 14-1 shows all signals of VREG3V3V2 associated with pins.

Table 14-1. VREG3V3V2 — Signal Properties

Name	Port	Function	Reset State	Pull Up
V_{DDR}	—	VREG3V3V2 power input (positive supply)	—	—
V_{DDA}	—	VREG3V3V2 quiet input (positive supply)	—	—
V_{SSA}	—	VREG3V3V2 quiet input (ground)	—	—
V_{DD}	—	VREG3V3V2 primary output (positive supply)	—	—
V_{SS}	—	VREG3V3V2 primary output (ground)	—	—
V_{DDPLL}	—	VREG3V3V2 secondary output (positive supply)	—	—
V_{SSPLL}	—	VREG3V3V2 secondary output (ground)	—	—
V_{REGEN} (optional)	—	VREG3V3V2 (Optional) Regulator Enable	—	—

NOTE

Check device overview chapter for connectivity of the signals.

14.2.1 V_{DDR} — Regulator Power Input

Signal V_{DDR} is the power input of VREG3V3V2. All currents sourced into the regulator loads flow through this pin. A chip external decoupling capacitor (100 nF...220 nF, X7R ceramic) between V_{DDR} and V_{SSR} can smoothen ripple on V_{DDR} .

For entering shutdown mode, pin V_{DDR} should also be tied to ground on devices without a V_{REGEN} pin.

14.2.2 V_{DDA} , V_{SSA} — Regulator Reference Supply

Signals V_{DDA}/V_{SSA} which are supposed to be relatively quiet are used to supply the analog parts of the regulator. Internal precision reference circuits are supplied from these signals. A chip external decoupling capacitor (100 nF...220 nF, X7R ceramic) between V_{DDA} and V_{SSA} can further improve the quality of this supply.

14.2.3 V_{DD} , V_{SS} — Regulator Output1 (Core Logic)

Signals V_{DD}/V_{SS} are the primary outputs of VREG3V3V2 that provide the power supply for the core logic. These signals are connected to device pins to allow external decoupling capacitors (100 nF...220 nF, X7R ceramic).

In shutdown mode an external supply at V_{DD}/V_{SS} can replace the voltage regulator.

14.2.4 V_{DDPLL} , V_{SSPLL} — Regulator Output2 (PLL)

Signals V_{DDPLL}/V_{SSPLL} are the secondary outputs of VREG3V3V2 that provide the power supply for the PLL and oscillator. These signals are connected to device pins to allow external decoupling capacitors (100 nF...220 nF, X7R ceramic).

In shutdown mode an external supply at V_{DDPLL}/V_{SSPLL} can replace the voltage regulator.

14.2.5 V_{REGEN} — Optional Regulator Enable

This optional signal is used to shutdown VREG3V3V2. In that case V_{DD}/V_{SS} and V_{DDPLL}/V_{SSPLL} must be provided externally. shutdown mode is entered with V_{REGEN} being low. If V_{REGEN} is high, the VREG3V3V2 is either in full-performance mode or in reduced-power mode.

For the connectivity of V_{REGEN} see device overview chapter.

NOTE

Switching from FPM or RPM to shutdown of VREG3V3V2 and vice versa is not supported while the MCU is powered.

14.3 Memory Map and Register Definition

This subsection provides a detailed description of all registers accessible in VREG3V3V2.

14.3.1 Module Memory Map

Figure 14-2 provides an overview of all used registers.

Table 14-2. VREG3V3V2 Memory Map

Address Offset	Use	Access
0x0000	VREG3V3V2 Control Register (VREGCTRL)	R/W

14.3.2 Register Descriptions

The following paragraphs describe, in address order, all the VREG3V3V2 registers and their individual bits.

14.3.2.1 VREG3V3V2 — Control Register (VREGCTRL)

The VREGCTRL register allows to separately enable features of VREG3V3V2.

Module Base + 0x0000

	7	6	5	4	3	2	1	0
R	0	0	0	0	0	LVDS	LVIE	LVIF
W								
Reset	0	0	0	0	0	0	0	0

 = Unimplemented or Reserved

Figure 14-2. VREG3V3 — Control Register (VREGCTRL)

Table 14-3. MCCTL1 Field Descriptions

Field	Description
2 LVDS	Low-Voltage Detect Status Bit — This read-only status bit reflects the input voltage. Writes have no effect. 0 Input voltage V_{DDA} is above level V_{LVID} or RPM or shutdown mode. 1 Input voltage V_{DDA} is below level V_{LVIA} and FPM.
1 LVIE	Low-Voltage Interrupt Enable Bit 0 Interrupt request is disabled. 1 Interrupt will be requested whenever LVIF is set.
0 LVIF	Low-Voltage Interrupt Flag — LVIF is set to 1 when LVDS status bit changes. This flag can only be cleared by writing a 1. Writing a 0 has no effect. If enabled (LVIE = 1), LVIF causes an interrupt request. 0 No change in LVDS bit. 1 LVDS bit has changed.

NOTE

On entering the reduced-power mode the LVIF is not cleared by the VREG3V3V2.

14.4 Functional Description

Block VREG3V3V2 is a voltage regulator as depicted in [Figure 14-1](#). The regulator functional elements are the regulator core (REG), a low-voltage detect module (LVD), a power-on reset module (POR) and a low-voltage reset module (LVR). There is also the regulator control block (CTRL) which represents the interface to the digital core logic but also manages the operating modes of VREG3V3V2.

14.4.1 REG — Regulator Core

VREG3V3V2, respectively its regulator core has two parallel, independent regulation loops (REG1 and REG2) that differ only in the amount of current that can be sourced to the connected loads. Therefore, only REG1 providing the supply at V_{DD}/V_{SS} is explained. The principle is also valid for REG2.

The regulator is a linear series regulator with a bandgap reference in its full-performance mode and a voltage clamp in reduced-power mode. All load currents flow from input V_{DDR} to V_{SS} or V_{SSPLL} , the reference circuits are connected to V_{DDA} and V_{SSA} .

14.4.2 Full-Performance Mode

In full-performance mode, a fraction of the output voltage (V_{DD}) and the bandgap reference voltage are fed to an operational amplifier. The amplified input voltage difference controls the gate of an output driver which basically is a large NMOS transistor connected to the output.

14.4.3 Reduced-Power Mode

In reduced-power mode, the driver gate is connected to a buffered fraction of the input voltage (V_{DDR}). The operational amplifier and the bandgap are disabled to reduce power consumption.

14.4.4 LVD — Low-Voltage Detect

sub-block LVD is responsible for generating the low-voltage interrupt (LVI). LVD monitors the input voltage ($V_{DDA}-V_{SSA}$) and continuously updates the status flag LVDS. Interrupt flag LVIF is set whenever status flag LVDS changes its value. The LVD is available in FPM and is inactive in reduced-power mode and shutdown mode.

14.4.5 POR — Power-On Reset

This functional block monitors output V_{DD} . If V_{DD} is below V_{POR} , signal POR is high, if it exceeds V_{POR} , the signal goes low. The transition to low forces the CPU in the power-on sequence.

Due to its role during chip power-up this module must be active in all operating modes of VREG3V3V2.

14.4.6 LVR — Low-Voltage Reset

Block LVR monitors the primary output voltage V_{DD} . If it drops below the assertion level (V_{LVRA}) signal LVR asserts and when rising above the deassertion level (V_{LVRD}) signal LVR negates again. The LVR function is available only in full-performance mode.

14.4.7 CTRL — Regulator Control

This part contains the register block of VREG3V3V2 and further digital functionality needed to control the operating modes. CTRL also represents the interface to the digital core logic.

14.5 Resets

This subsection describes how VREG3V3V2 controls the reset of the MCU. The reset values of registers and signals are provided in [Section 14.3, “Memory Map and Register Definition”](#). Possible reset sources are listed in [Table 14-4](#).

Table 14-4. VREG3V3V2 — Reset Sources

Reset Source	Local Enable
Power-on reset	Always active
Low-voltage reset	Available only in full-performance mode

14.5.1 Power-On Reset

During chip power-up the digital core may not work if its supply voltage V_{DD} is below the POR deassertion level (V_{POR}). Therefore, signal POR which forces the other blocks of the device into reset is kept high until V_{DD} exceeds V_{POR} . Then POR becomes low and the reset generator of the device continues the start-up sequence. The power-on reset is active in all operation modes of VREG3V3V2.

14.5.2 Low-Voltage Reset

For details on low-voltage reset see [Section 14.4.6, “LVR — Low-Voltage Reset”](#).

14.6 Interrupts

This subsection describes all interrupts originated by VREG3V3V2.

The interrupt vectors requested by VREG3V3V2 are listed in [Table 14-5](#). Vector addresses and interrupt priorities are defined at MCU level.

Table 14-5. VREG3V3V2 — Interrupt Vectors

Interrupt Source	Local Enable
Low Voltage Interrupt (LVI)	LVIE = 1; Available only in full-performance mode

14.6.1 LVI — Low-Voltage Interrupt

In FPM VREG3V3V2 monitors the input voltage V_{DDA} . Whenever V_{DDA} drops below level V_{LVIA} the status bit LVDS is set to 1. Vice versa, LVDS is reset to 0 when V_{DDA} rises above level V_{LVID} . An interrupt, indicated by flag LVIF = 1, is triggered by any change of the status bit LVDS if interrupt enable bit LVIE = 1.

NOTE

On entering the reduced-power mode, the LVIF is not cleared by the VREG3V3V2.

Chapter 15

Background Debug Module (BDMV4) Block Description

15.1 Introduction

This section describes the functionality of the background debug module (BDM) sub-block of the HCS12 core platform.

A block diagram of the BDM is shown in [Figure 15-1](#).

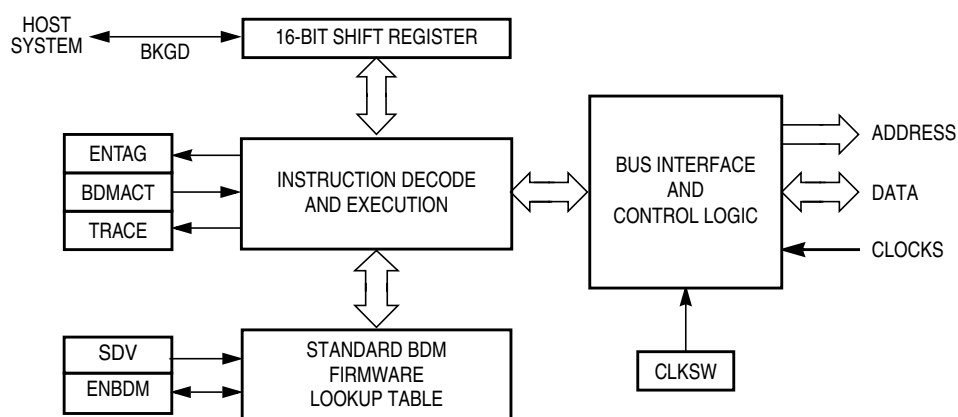

Figure 15-1. BDM Block Diagram

The background debug module (BDM) sub-block is a single-wire, background debug system implemented in on-chip hardware for minimal CPU intervention. All interfacing with the BDM is done via the BKGD pin.

BDMV4 has enhanced capability for maintaining synchronization between the target and host while allowing more flexibility in clock rates. This includes a sync signal to show the clock rate and a handshake signal to indicate when an operation is complete. The system is backwards compatible with older external interfaces.

15.1.1 Features

- Single-wire communication with host development system
- BDMV4 (and BDM2): Enhanced capability for allowing more flexibility in clock rates
- BDMV4: SYNC command to determine communication rate
- BDMV4: GO_UNTIL command
- BDMV4: Hardware handshake protocol to increase the performance of the serial communication
- Active out of reset in special single-chip mode

- Nine hardware commands using free cycles, if available, for minimal CPU intervention
- Hardware commands not requiring active BDM
- 15 firmware commands execute from the standard BDM firmware lookup table
- Instruction tagging capability
- Software control of BDM operation during wait mode
- Software selectable clocks
- When secured, hardware commands are allowed to access the register space in special single-chip mode, if the FLASH and EEPROM erase tests fail.

15.1.2 Modes of Operation

BDM is available in all operating modes but must be enabled before firmware commands are executed. Some system peripherals may have a control bit which allows suspending the peripheral function during background debug mode.

15.1.2.1 Regular Run Modes

All of these operations refer to the part in run mode. The BDM does not provide controls to conserve power during run mode.

- Normal operation
General operation of the BDM is available and operates the same in all normal modes.
- Special single-chip mode
In special single-chip mode, background operation is enabled and active out of reset. This allows programming a system with blank memory.
- Special peripheral mode
BDM is enabled and active immediately out of reset. BDM can be disabled by clearing the BDMACT bit in the BDM status (BDMSTS) register. The BDM serial system should not be used in special peripheral mode.
- Emulation modes
General operation of the BDM is available and operates the same as in normal modes.

15.1.2.2 Secure Mode Operation

If the part is in secure mode, the operation of the BDM is reduced to a small subset of its regular run mode operation. Secure operation prevents access to FLASH or EEPROM other than allowing erasure.

15.2 External Signal Description

A single-wire interface pin is used to communicate with the BDM system. Two additional pins are used for instruction tagging. These pins are part of the multiplexed external bus interface (MEBI) sub-block and all interfacing between the MEBI and BDM is done within the core interface boundary. Functional descriptions of the pins are provided below for completeness.

- BKGD — Background interface pin
- $\overline{\text{TAGHI}}$ — High byte instruction tagging pin
- $\overline{\text{TAGLO}}$ — Low byte instruction tagging pin
- BKGD and $\overline{\text{TAGHI}}$ share the same pin.
- $\overline{\text{TAGLO}}$ and $\overline{\text{LSTRB}}$ share the same pin.

NOTE

Generally these pins are shared as described, but it is best to check the device overview chapter to make certain. All MCUs at the time of this writing have followed this pin sharing scheme.

15.2.1 BKGD — Background Interface Pin

Debugging control logic communicates with external devices serially via the single-wire background interface pin (BKGD). During reset, this pin is a mode select input which selects between normal and special modes of operation. After reset, this pin becomes the dedicated serial interface pin for the background debug mode.

15.2.2 $\overline{\text{TAGHI}}$ — High Byte Instruction Tagging Pin

This pin is used to tag the high byte of an instruction. When instruction tagging is on, a logic 0 at the falling edge of the external clock (ECLK) tags the high half of the instruction word being read into the instruction queue.

15.2.3 $\overline{\text{TAGLO}}$ — Low Byte Instruction Tagging Pin

This pin is used to tag the low byte of an instruction. When instruction tagging is on and low strobe is enabled, a logic 0 at the falling edge of the external clock (ECLK) tags the low half of the instruction word being read into the instruction queue.

15.3 Memory Map and Register Definition

A summary of the registers associated with the BDM is shown in [Figure 15-2](#). Registers are accessed by host-driven communications to the BDM hardware using READ_BD and WRITE_BD commands. Detailed descriptions of the registers and associated bits are given in the subsections that follow.

15.3.1 Module Memory Map

Table 15-1. INT Memory Map

Register Address	Use	Access
0xFF00	Reserved	—
0xFF01	BDM Status Register (BDMSTS)	R/W
0xFF02– 0xFF05	Reserved	—
0xFF06	BDM CCR Holding Register (BDMCCR)	R/W
0xFF07	BDM Internal Register Position (BDMINR)	R
0xFF08– 0xFF0B	Reserved	—

15.3.2 Register Descriptions

Register Name		Bit 7	6	5	4	3	2	1	Bit 0
0xFF00 Reserved	R	X	X	X	X	X	X	0	0
	W								
0xFF01 BDMSTS	R	ENBDM	BDMACT	ENTAG	SDV	TRACE	CLKSW	UNSEC	0
	W								
0xFF02 Reserved	R	X	X	X	X	X	X	X	X
	W								
0xFF03 Reserved	R	X	X	X	X	X	X	X	X
	W								
0xFF04 Reserved	R	X	X	X	X	X	X	X	X
	W								
0xFF05 Reserved	R	X	X	X	X	X	X	X	X
	W								
0xFF06 BDMCCR	R	CCR7	CCR6	CCR5	CCR4	CCR3	CCR2	CCR1	CCR0
	W								
0xFF07 BDMINR	R	0	REG14	REG13	REG12	REG11	0	0	0
	W								
0xFF08 Reserved	R	0	0	0	0	0	0	0	0
	W								
0xFF09 Reserved	R	0	0	0	0	0	0	0	0
	W								
0xFF0A Reserved	R	X	X	X	X	X	X	X	X
	W								
0xFF0B Reserved	R	X	X	X	X	X	X	X	X
	W								

<table border="1" style="display: inline-table; vertical-align: middle;"><tr><td> </td></tr></table>		= Unimplemented, Reserved	<table border="1" style="display: inline-table; vertical-align: middle;"><tr><td> </td></tr></table>		= Implemented (do not alter)
<table border="1" style="display: inline-table; vertical-align: middle;"><tr><td>X</td></tr></table>	X	= Indeterminate	<table border="1" style="display: inline-table; vertical-align: middle;"><tr><td>0</td></tr></table>	0	= Always read zero
X					
0					

Figure 15-2. BDM Register Summary

15.3.2.1 BDM Status Register (BDMSTS)

0xFF01

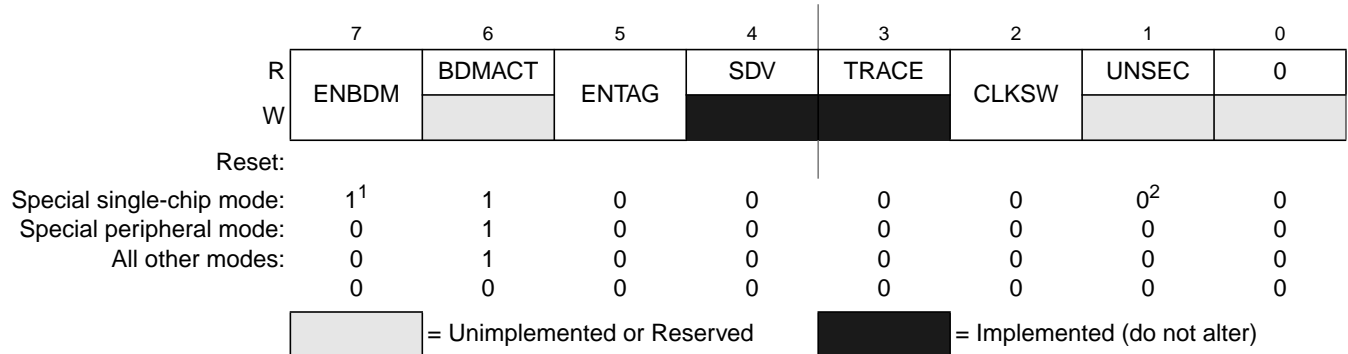

Figure 15-3. BDM Status Register (BDMSTS)

Note:

- ¹ ENBDM is read as "1" by a debugging environment in Special single-chip mode when the device is not secured or secured but fully erased (Flash and EEPROM). This is because the ENBDM bit is set by the standard firmware before a BDM command can be fully transmitted and executed.
- ² UNSEC is read as "1" by a debugging environment in Special single-chip mode when the device is secured and fully erased, else it is "0" and can only be read if not secure (see also bit description).

Read: All modes through BDM operation

Write: All modes but subject to the following:

- BDMACT can only be set by BDM hardware upon entry into BDM. It can only be cleared by the standard BDM firmware lookup table upon exit from BDM active mode.
- CLKSW can only be written via BDM hardware or standard BDM firmware write commands.
- All other bits, while writable via BDM hardware or standard BDM firmware write commands, should only be altered by the BDM hardware or standard firmware lookup table as part of BDM command execution.
- ENBDM should only be set via a BDM hardware command if the BDM firmware commands are needed. (This does not apply in special single-chip mode).

Table 15-2. BDMSTS Field Descriptions

Field	Description
<p>7 ENBDM</p>	<p>Enable BDM — This bit controls whether the BDM is enabled or disabled. When enabled, BDM can be made active to allow firmware commands to be executed. When disabled, BDM cannot be made active but BDM hardware commands are allowed. 0 BDM disabled 1 BDM enabled Note: ENBDM is set by the firmware immediately out of reset in special single-chip mode. In secure mode, this bit will not be set by the firmware until after the EEPROM and FLASH erase verify tests are complete.</p>
<p>6 BDMACT</p>	<p>BDM Active Status — This bit becomes set upon entering BDM. The standard BDM firmware lookup table is then enabled and put into the memory map. BDMACT is cleared by a carefully timed store instruction in the standard BDM firmware as part of the exit sequence to return to user code and remove the BDM memory from the map. 0 BDM not active 1 BDM active</p>
<p>5 ENTAG</p>	<p>Tagging Enable — This bit indicates whether instruction tagging in enabled or disabled. It is set when the TAGGO command is executed and cleared when BDM is entered. The serial system is disabled and the tag function enabled 16 cycles after this bit is written. BDM cannot process serial commands while tagging is active. 0 Tagging not enabled or BDM active 1 Tagging enabled</p>
<p>4 SDV</p>	<p>Shift Data Valid — This bit is set and cleared by the BDM hardware. It is set after data has been transmitted as part of a firmware read command or after data has been received as part of a firmware write command. It is cleared when the next BDM command has been received or BDM is exited. SDV is used by the standard BDM firmware to control program flow execution. 0 Data phase of command not complete 1 Data phase of command is complete</p>
<p>3 TRACE</p>	<p>TRACE1 BDM Firmware Command is Being Executed — This bit gets set when a BDM TRACE1 firmware command is first recognized. It will stay set as long as continuous back-to-back TRACE1 commands are executed. This bit will get cleared when the next command that is not a TRACE1 command is recognized. 0 TRACE1 command is not being executed 1 TRACE1 command is being executed</p>

Table 15-2. BDMSTS Field Descriptions (continued)

Field	Description
2 CLKSW	<p>Clock Switch — The CLKSW bit controls which clock the BDM operates with. It is only writable from a hardware BDM command. A 150 cycle delay at the clock speed that is active during the data portion of the command will occur before the new clock source is guaranteed to be active. The start of the next BDM command uses the new clock for timing subsequent BDM communications.</p> <p>Table 15-3 shows the resulting BDM clock source based on the CLKSW and the PLLSEL (PII select from the clock and reset generator) bits.</p> <p>Note: The BDM alternate clock source can only be selected when CLKSW = 0 and PLLSEL = 1. The BDM serial interface is now fully synchronized to the alternate clock source, when enabled. This eliminates frequency restriction on the alternate clock which was required on previous versions. Refer to the device overview section to determine which clock connects to the alternate clock source input.</p> <p>Note: If the acknowledge function is turned on, changing the CLKSW bit will cause the ACK to be at the new rate for the write command which changes it.</p>
1 UNSEC	<p>Unsecure — This bit is only writable in special single-chip mode from the BDM secure firmware and always gets reset to zero. It is in a zero state as secure mode is entered so that the secure BDM firmware lookup table is enabled and put into the memory map along with the standard BDM firmware lookup table.</p> <p>The secure BDM firmware lookup table verifies that the on-chip EEPROM and FLASH EEPROM are erased. This being the case, the UNSEC bit is set and the BDM program jumps to the start of the standard BDM firmware lookup table and the secure BDM firmware lookup table is turned off. If the erase test fails, the UNSEC bit will not be asserted.</p> <p>0 System is in a secured mode 1 System is in a unsecured mode</p> <p>Note: When UNSEC is set, security is off and the user can change the state of the secure bits in the on-chip FLASH EEPROM. Note that if the user does not change the state of the bits to “unsecured” mode, the system will be secured again when it is next taken out of reset.</p>

Table 15-3. BDM Clock Sources

PLLSEL	CLKSW	BDMCLK
0	0	Bus clock
0	1	Bus clock
1	0	Alternate clock (refer to the device overview chapter to determine the alternate clock source)
1	1	Bus clock dependent on the PLL

15.3.2.2 BDM CCR Holding Register (BDMCCR)

0xFF06

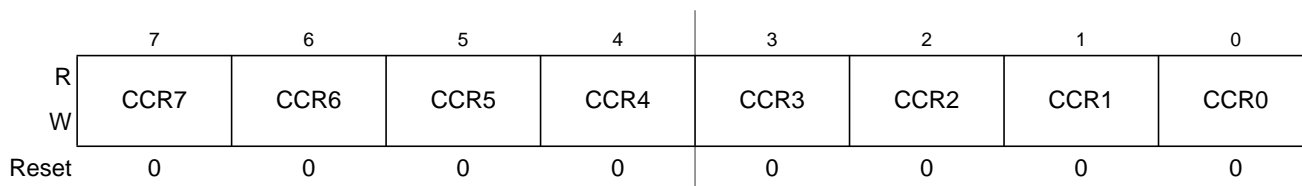

Figure 15-4. BDM CCR Holding Register (BDMCCR)

Read: All modes

Write: All modes

NOTE

When BDM is made active, the CPU stores the value of the CCR register in the BDMCCR register. However, out of special single-chip reset, the BDMCCR is set to 0xD8 and not 0xD0 which is the reset value of the CCR register.

When entering background debug mode, the BDM CCR holding register is used to save the contents of the condition code register of the user’s program. It is also used for temporary storage in the standard BDM firmware mode. The BDM CCR holding register can be written to modify the CCR value.

15.3.2.3 BDM Internal Register Position Register (BDMINR)

0xFF07

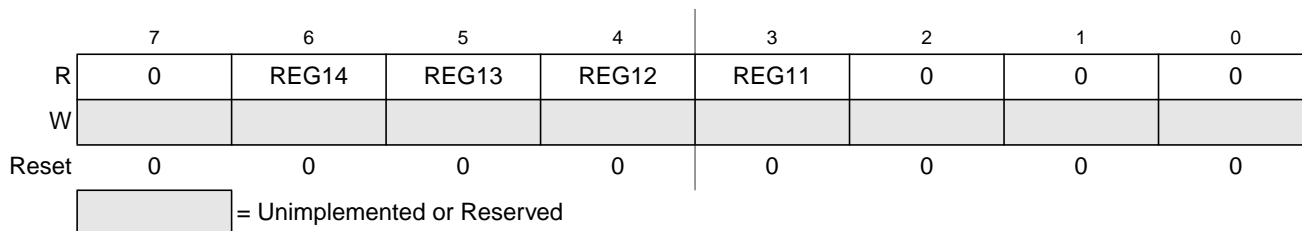

Figure 15-5. BDM Internal Register Position (BDMINR)

Read: All modes

Write: Never

Table 15-4. BDMINR Field Descriptions

Field	Description
6:3 REG[14:11]	Internal Register Map Position — These four bits show the state of the upper five bits of the base address for the system’s relocatable register block. BDMINR is a shadow of the INITRG register which maps the register block to any 2K byte space within the first 32K bytes of the 64K byte address space.

15.4 Functional Description

The BDM receives and executes commands from a host via a single wire serial interface. There are two types of BDM commands, namely, hardware commands and firmware commands.

Hardware commands are used to read and write target system memory locations and to enter active background debug mode, see [Section 15.4.3, “BDM Hardware Commands.”](#) Target system memory includes all memory that is accessible by the CPU.

Firmware commands are used to read and write CPU resources and to exit from active background debug mode, see [Section 15.4.4, “Standard BDM Firmware Commands.”](#) The CPU resources referred to are the accumulator (D), X index register (X), Y index register (Y), stack pointer (SP), and program counter (PC).

Hardware commands can be executed at any time and in any mode excluding a few exceptions as highlighted, see [Section 15.4.3, “BDM Hardware Commands.”](#) Firmware commands can only be executed when the system is in active background debug mode (BDM).

15.4.1 Security

If the user resets into special single-chip mode with the system secured, a secured mode BDM firmware lookup table is brought into the map overlapping a portion of the standard BDM firmware lookup table. The secure BDM firmware verifies that the on-chip EEPROM and FLASH EEPROM are erased. This being the case, the UNSEC bit will get set. The BDM program jumps to the start of the standard BDM firmware and the secured mode BDM firmware is turned off and all BDM commands are allowed. If the EEPROM or FLASH do not verify as erased, the BDM firmware sets the ENBDM bit, without asserting UNSEC, and the firmware enters a loop. This causes the BDM hardware commands to become enabled, but does not enable the firmware commands. This allows the BDM hardware to be used to erase the EEPROM and FLASH. After execution of the secure firmware, regardless of the results of the erase tests, the CPU registers, INITEE and PPAGE, will no longer be in their reset state.

15.4.2 Enabling and Activating BDM

The system must be in active BDM to execute standard BDM firmware commands. BDM can be activated only after being enabled. BDM is enabled by setting the ENBDM bit in the BDM status (BDMSTS) register. The ENBDM bit is set by writing to the BDM status (BDMSTS) register, via the single-wire interface, using a hardware command such as WRITE_BD_BYTE.

After being enabled, BDM is activated by one of the following¹:

- Hardware BACKGROUND command
- BDM external instruction tagging mechanism
- CPU BGND instruction
- Breakpoint sub-block's force or tag mechanism²

When BDM is activated, the CPU finishes executing the current instruction and then begins executing the firmware in the standard BDM firmware lookup table. When BDM is activated by the breakpoint

1. BDM is enabled and active immediately out of special single-chip reset.

2. This method is only available on systems that have a breakpoint or a debug sub-block.

sub-block, the type of breakpoint used determines if BDM becomes active before or after execution of the next instruction.

NOTE

If an attempt is made to activate BDM before being enabled, the CPU resumes normal instruction execution after a brief delay. If BDM is not enabled, any hardware BACKGROUND commands issued are ignored by the BDM and the CPU is not delayed.

In active BDM, the BDM registers and standard BDM firmware lookup table are mapped to addresses 0xFF00 to 0xFFFF. BDM registers are mapped to addresses 0xFF00 to 0xFF07. The BDM uses these registers which are readable anytime by the BDM. However, these registers are not readable by user programs.

15.4.3 BDM Hardware Commands

Hardware commands are used to read and write target system memory locations and to enter active background debug mode. Target system memory includes all memory that is accessible by the CPU such as on-chip RAM, EEPROM, FLASH EEPROM, I/O and control registers, and all external memory.

Hardware commands are executed with minimal or no CPU intervention and do not require the system to be in active BDM for execution, although they can continue to be executed in this mode. When executing a hardware command, the BDM sub-block waits for a free CPU bus cycle so that the background access does not disturb the running application program. If a free cycle is not found within 128 clock cycles, the CPU is momentarily frozen so that the BDM can steal a cycle. When the BDM finds a free cycle, the operation does not intrude on normal CPU operation provided that it can be completed in a single cycle. However, if an operation requires multiple cycles the CPU is frozen until the operation is complete, even though the BDM found a free cycle.

The BDM hardware commands are listed in [Table 15-5](#).

Table 15-5. Hardware Commands

Command	Opcode (hex)	Data	Description
BACKGROUND	90	None	Enter background mode if firmware is enabled. If enabled, an ACK will be issued when the part enters active background mode.
ACK_ENABLE	D5	None	Enable handshake. Issues an ACK pulse after the command is executed.
ACK_DISABLE	D6	None	Disable handshake. This command does not issue an ACK pulse.
READ_BD_BYTE	E4	16-bit address 16-bit data out	Read from memory with standard BDM firmware lookup table in map. Odd address data on low byte; even address data on high byte.
READ_BD_WORD	EC	16-bit address 16-bit data out	Read from memory with standard BDM firmware lookup table in map. Must be aligned access.
READ_BYTE	E0	16-bit address 16-bit data out	Read from memory with standard BDM firmware lookup table out of map. Odd address data on low byte; even address data on high byte.
READ_WORD	E8	16-bit address 16-bit data out	Read from memory with standard BDM firmware lookup table out of map. Must be aligned access.
WRITE_BD_BYTE	C4	16-bit address 16-bit data in	Write to memory with standard BDM firmware lookup table in map. Odd address data on low byte; even address data on high byte.
WRITE_BD_WORD	CC	16-bit address 16-bit data in	Write to memory with standard BDM firmware lookup table in map. Must be aligned access.
WRITE_BYTE	C0	16-bit address 16-bit data in	Write to memory with standard BDM firmware lookup table out of map. Odd address data on low byte; even address data on high byte.
WRITE_WORD	C8	16-bit address 16-bit data in	Write to memory with standard BDM firmware lookup table out of map. Must be aligned access.

NOTE:

If enabled, ACK will occur when data is ready for transmission for all BDM READ commands and will occur after the write is complete for all BDM WRITE commands.

The READ_BD and WRITE_BD commands allow access to the BDM register locations. These locations are not normally in the system memory map but share addresses with the application in memory. To distinguish between physical memory locations that share the same address, BDM memory resources are enabled just for the READ_BD and WRITE_BD access cycle. This allows the BDM to access BDM locations unobtrusively, even if the addresses conflict with the application memory map.

15.4.4 Standard BDM Firmware Commands

Firmware commands are used to access and manipulate CPU resources. The system must be in active BDM to execute standard BDM firmware commands, see [Section 15.4.2, “Enabling and Activating BDM.”](#) Normal instruction execution is suspended while the CPU executes the firmware located in the standard BDM firmware lookup table. The hardware command BACKGROUND is the usual way to activate BDM.

As the system enters active BDM, the standard BDM firmware lookup table and BDM registers become visible in the on-chip memory map at 0xFF00–0xFFFF, and the CPU begins executing the standard BDM

firmware. The standard BDM firmware watches for serial commands and executes them as they are received.

The firmware commands are shown in [Table 15-6](#).

Table 15-6. Firmware Commands

Command ¹	Opcode (hex)	Data	Description
READ_NEXT	62	16-bit data out	Increment X by 2 ($X = X + 2$), then read word X points to.
READ_PC	63	16-bit data out	Read program counter.
READ_D	64	16-bit data out	Read D accumulator.
READ_X	65	16-bit data out	Read X index register.
READ_Y	66	16-bit data out	Read Y index register.
READ_SP	67	16-bit data out	Read stack pointer.
WRITE_NEXT	42	16-bit data in	Increment X by 2 ($X = X + 2$), then write word to location pointed to by X.
WRITE_PC	43	16-bit data in	Write program counter.
WRITE_D	44	16-bit data in	Write D accumulator.
WRITE_X	45	16-bit data in	Write X index register.
WRITE_Y	46	16-bit data in	Write Y index register.
WRITE_SP	47	16-bit data in	Write stack pointer.
GO	08	None	Go to user program. If enabled, ACK will occur when leaving active background mode.
GO_UNTIL ²	0C	None	Go to user program. If enabled, ACK will occur upon returning to active background mode.
TRACE1	10	None	Execute one user instruction then return to active BDM. If enabled, ACK will occur upon returning to active background mode.
TAGGO	18	None	Enable tagging and go to user program. There is no ACK pulse related to this command.

¹ If enabled, ACK will occur when data is ready for transmission for all BDM READ commands and will occur after the write is complete for all BDM WRITE commands.

² Both WAIT (with clocks to the S12 CPU core disabled) and STOP disable the ACK function. The GO_UNTIL command will not get an Acknowledge if one of these two CPU instructions occurs before the "UNTIL" instruction. This can be a problem for any instruction that uses ACK, but GO_UNTIL is a lot more difficult for the development tool to time-out.

15.4.5 BDM Command Structure

Hardware and firmware BDM commands start with an 8-bit opcode followed by a 16-bit address and/or a 16-bit data word depending on the command. All the read commands return 16 bits of data despite the byte or word implication in the command name.

NOTE

8-bit reads return 16-bits of data, of which, only one byte will contain valid data. If reading an even address, the valid data will appear in the MSB. If reading an odd address, the valid data will appear in the LSB.

NOTE

16-bit misaligned reads and writes are not allowed. If attempted, the BDM will ignore the least significant bit of the address and will assume an even address from the remaining bits.

For hardware data read commands, the external host must wait 150 bus clock cycles after sending the address before attempting to obtain the read data. This is to be certain that valid data is available in the BDM shift register, ready to be shifted out. For hardware write commands, the external host must wait 150 bus clock cycles after sending the data to be written before attempting to send a new command. This is to avoid disturbing the BDM shift register before the write has been completed. The 150 bus clock cycle delay in both cases includes the maximum 128 cycle delay that can be incurred as the BDM waits for a free cycle before stealing a cycle.

For firmware read commands, the external host should wait 44 bus clock cycles after sending the command opcode and before attempting to obtain the read data. This includes the potential of an extra 7 cycles when the access is external with a narrow bus access (+1 cycle) and / or a stretch (+1, 2, or 3 cycles), (7 cycles could be needed if both occur). The 44 cycle wait allows enough time for the requested data to be made available in the BDM shift register, ready to be shifted out.

NOTE

This timing has increased from previous BDM modules due to the new capability in which the BDM serial interface can potentially run faster than the bus. On previous BDM modules this extra time could be hidden within the serial time.

For firmware write commands, the external host must wait 32 bus clock cycles after sending the data to be written before attempting to send a new command. This is to avoid disturbing the BDM shift register before the write has been completed.

The external host should wait 64 bus clock cycles after a TRACE1 or GO command before starting any new serial command. This is to allow the CPU to exit gracefully from the standard BDM firmware lookup table and resume execution of the user code. Disturbing the BDM shift register prematurely may adversely affect the exit from the standard BDM firmware lookup table.

NOTE

If the bus rate of the target processor is unknown or could be changing, it is recommended that the ACK (acknowledge function) be used to indicate when an operation is complete. When using ACK, the delay times are automated.

Figure 15-6 represents the BDM command structure. The command blocks illustrate a series of eight bit times starting with a falling edge. The bar across the top of the blocks indicates that the BKGD line idles in the high state. The time for an 8-bit command is $8 \cdot 16$ target clock cycles.¹

1. Target clock cycles are cycles measured using the target MCU's serial clock rate. See [Section 15.4.6, "BDM Serial Interface,"](#) and [Section 15.3.2.1, "BDM Status Register \(BDMSTS\),"](#) for information on how serial clock rate is selected.

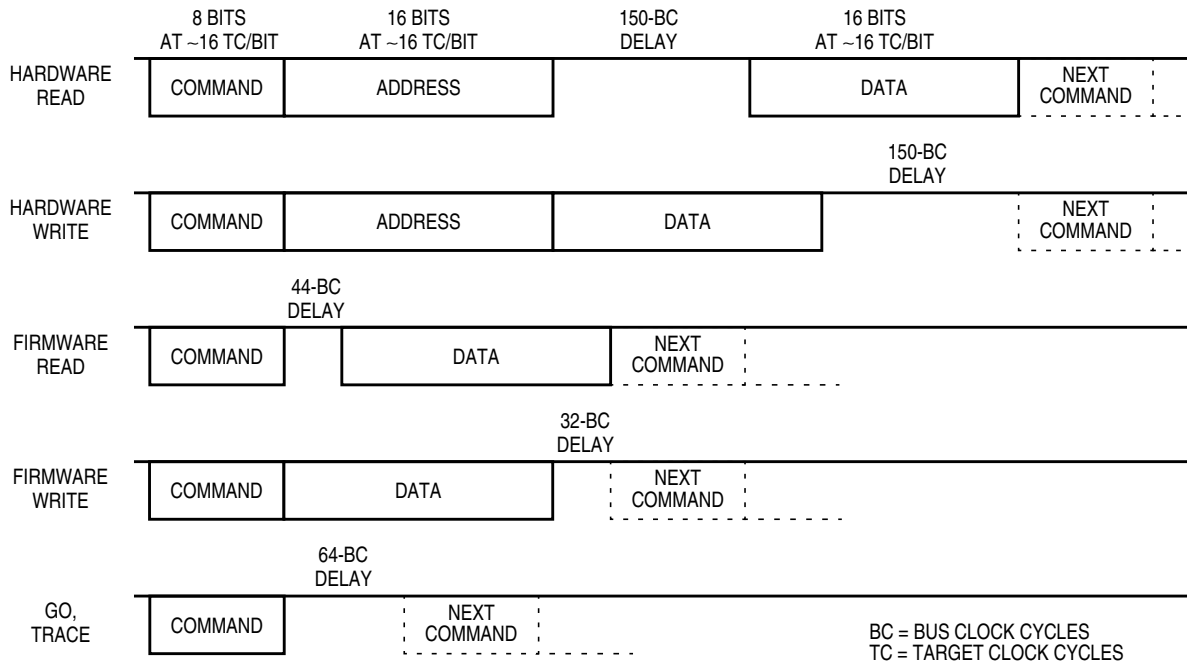

Figure 15-6. BDM Command Structure

15.4.6 BDM Serial Interface

The BDM communicates with external devices serially via the BKGD pin. During reset, this pin is a mode select input which selects between normal and special modes of operation. After reset, this pin becomes the dedicated serial interface pin for the BDM.

The BDM serial interface is timed using the clock selected by the CLKS_W bit in the status register see [Section 15.3.2.1, “BDM Status Register \(BDMSTS\).”](#) This clock will be referred to as the target clock in the following explanation.

The BDM serial interface uses a clocking scheme in which the external host generates a falling edge on the BKGD pin to indicate the start of each bit time. This falling edge is sent for every bit whether data is transmitted or received. Data is transferred most significant bit (MSB) first at 16 target clock cycles per bit. The interface times out if 512 clock cycles occur between falling edges from the host.

The BKGD pin is a pseudo open-drain pin and has an weak on-chip active pull-up that is enabled at all times. It is assumed that there is an external pull-up and that drivers connected to BKGD do not typically drive the high level. Because R-C rise time could be unacceptably long, the target system and host provide brief driven-high (speedup) pulses to drive BKGD to a logic 1. The source of this speedup pulse is the host for transmit cases and the target for receive cases.

The timing for host-to-target is shown in [Figure 15-7](#) and that of target-to-host in [Figure 15-8](#) and [Figure 15-9](#). All four cases begin when the host drives the BKGD pin low to generate a falling edge. Because the host and target are operating from separate clocks, it can take the target system up to one full clock cycle to recognize this edge. The target measures delays from this perceived start of the bit time while the host measures delays from the point it actually drove BKGD low to start the bit up to one target

clock cycle earlier. Synchronization between the host and target is established in this manner at the start of every bit time.

Figure 15-7 shows an external host transmitting a logic 1 and transmitting a logic 0 to the BKGD pin of a target system. The host is asynchronous to the target, so there is up to a one clock-cycle delay from the host-generated falling edge to where the target recognizes this edge as the beginning of the bit time. Ten target clock cycles later, the target senses the bit level on the BKGD pin. Internal glitch detect logic requires the pin be driven high no later that eight target clock cycles after the falling edge for a logic 1 transmission.

Because the host drives the high speedup pulses in these two cases, the rising edges look like digitally driven signals.

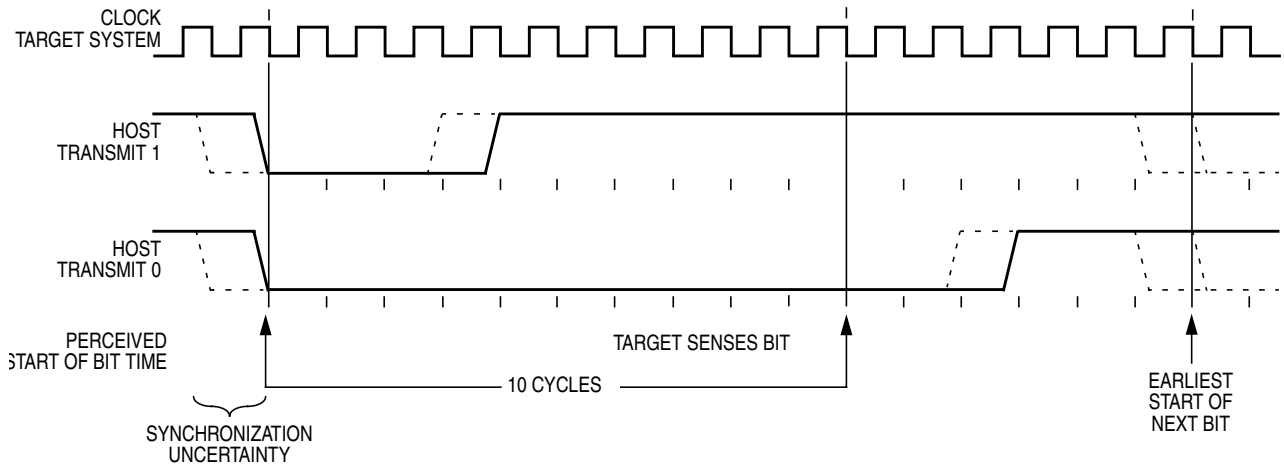

Figure 15-7. BDM Host-to-Target Serial Bit Timing

The receive cases are more complicated. Figure 15-8 shows the host receiving a logic 1 from the target system. Because the host is asynchronous to the target, there is up to one clock-cycle delay from the host-generated falling edge on BKGD to the perceived start of the bit time in the target. The host holds the BKGD pin low long enough for the target to recognize it (at least two target clock cycles). The host must release the low drive before the target drives a brief high speedup pulse seven target clock cycles after the perceived start of the bit time. The host should sample the bit level about 10 target clock cycles after it started the bit time.

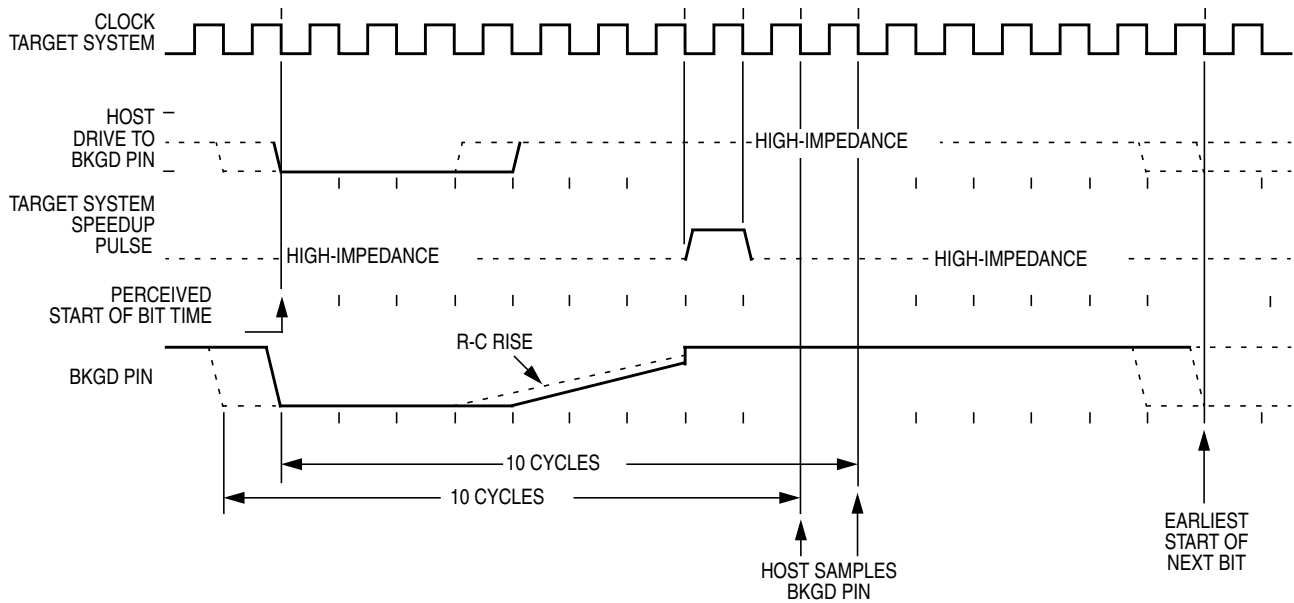

Figure 15-8. BDM Target-to-Host Serial Bit Timing (Logic 1)

Figure 15-9 shows the host receiving a logic 0 from the target. Because the host is asynchronous to the target, there is up to a one clock-cycle delay from the host-generated falling edge on BKGD to the start of the bit time as perceived by the target. The host initiates the bit time but the target finishes it. Because the target wants the host to receive a logic 0, it drives the BKGD pin low for 13 target clock cycles then briefly drives it high to speed up the rising edge. The host samples the bit level about 10 target clock cycles after starting the bit time.

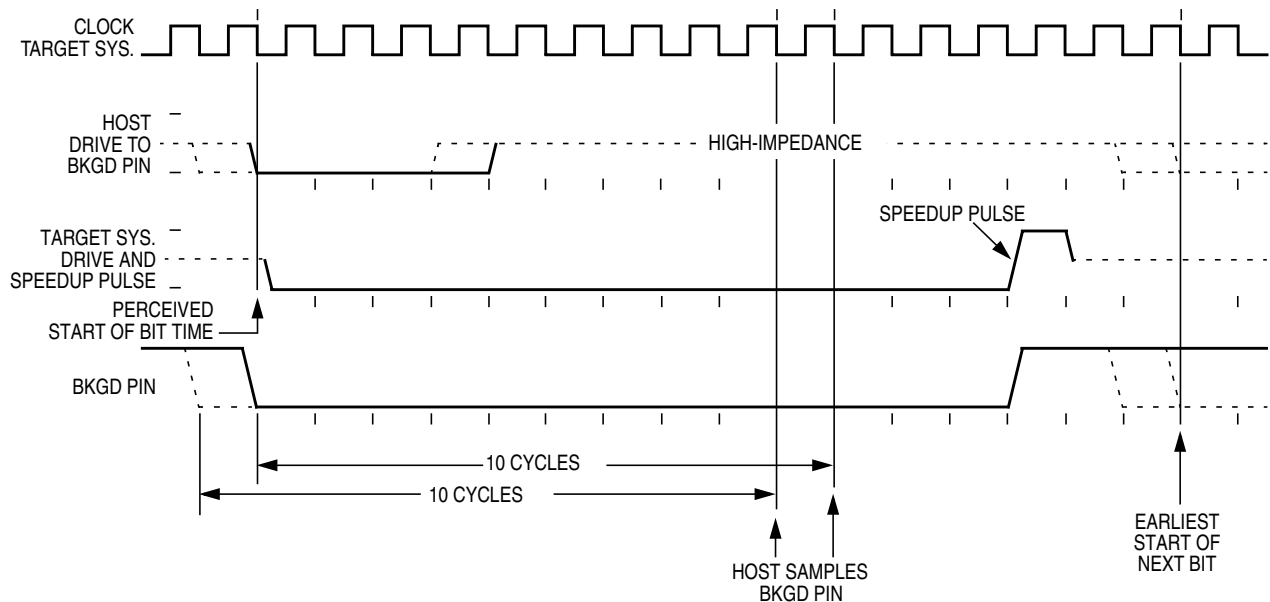

Figure 15-9. BDM Target-to-Host Serial Bit Timing (Logic 0)

15.4.7 Serial Interface Hardware Handshake Protocol

BDM commands that require CPU execution are ultimately treated at the MCU bus rate. Because the BDM clock source can be asynchronously related to the bus frequency, when $CLKSW = 0$, it is very helpful to provide a handshake protocol in which the host could determine when an issued command is executed by the CPU. The alternative is to always wait the amount of time equal to the appropriate number of cycles at the slowest possible rate the clock could be running. This sub-section will describe the hardware handshake protocol.

The hardware handshake protocol signals to the host controller when an issued command was successfully executed by the target. This protocol is implemented by a 16 serial clock cycle low pulse followed by a brief speedup pulse in the BKGD pin. This pulse is generated by the target MCU when a command, issued by the host, has been successfully executed (see Figure 15-10). This pulse is referred to as the ACK pulse. After the ACK pulse has finished: the host can start the bit retrieval if the last issued command was a read command, or start a new command if the last command was a write command or a control command (BACKGROUND, GO, GO_UNTIL, or TRACE1). The ACK pulse is not issued earlier than 32 serial clock cycles after the BDM command was issued. The end of the BDM command is assumed to be the 16th tick of the last bit. This minimum delay assures enough time for the host to perceive the ACK pulse. Note also that, there is no upper limit for the delay between the command and the related ACK pulse, because the command execution depends upon the CPU bus frequency, which in some cases could be very slow compared to the serial communication rate. This protocol allows a great flexibility for the POD designers, because it does not rely on any accurate time measurement or short response time to any event in the serial communication.

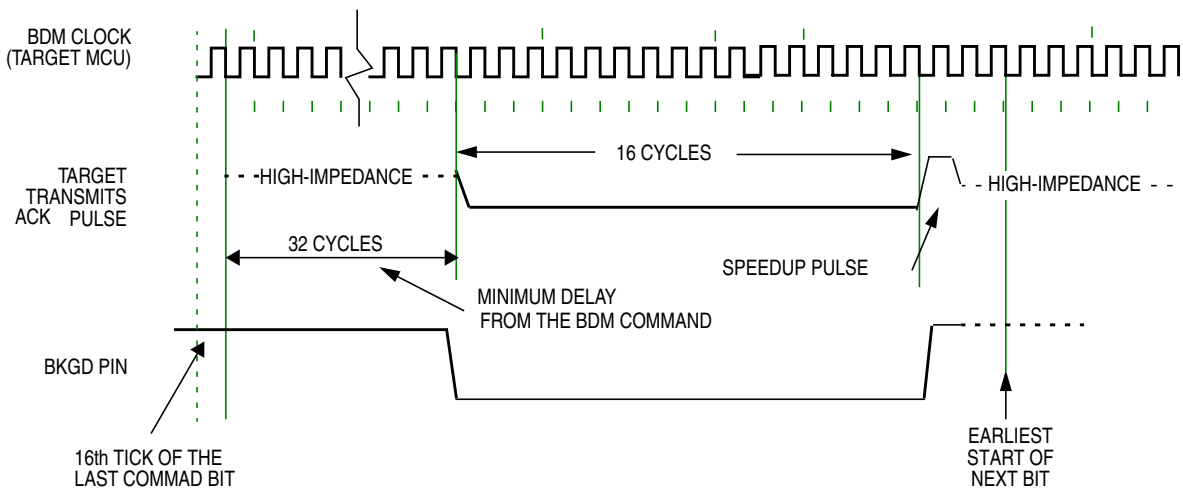

Figure 15-10. Target Acknowledge Pulse (ACK)

NOTE

If the ACK pulse was issued by the target, the host assumes the previous command was executed. If the CPU enters WAIT or STOP prior to executing a hardware command, the ACK pulse will not be issued meaning that the BDM command was not executed. After entering wait or stop mode, the BDM command is no longer pending.

Figure 15-11 shows the ACK handshake protocol in a command level timing diagram. The READ_BYTE instruction is used as an example. First, the 8-bit instruction opcode is sent by the host, followed by the address of the memory location to be read. The target BDM decodes the instruction. A bus cycle is grabbed (free or stolen) by the BDM and it executes the READ_BYTE operation. Having retrieved the data, the BDM issues an ACK pulse to the host controller, indicating that the addressed byte is ready to be retrieved. After detecting the ACK pulse, the host initiates the byte retrieval process. Note that data is sent in the form of a word and the host needs to determine which is the appropriate byte based on whether the address was odd or even.

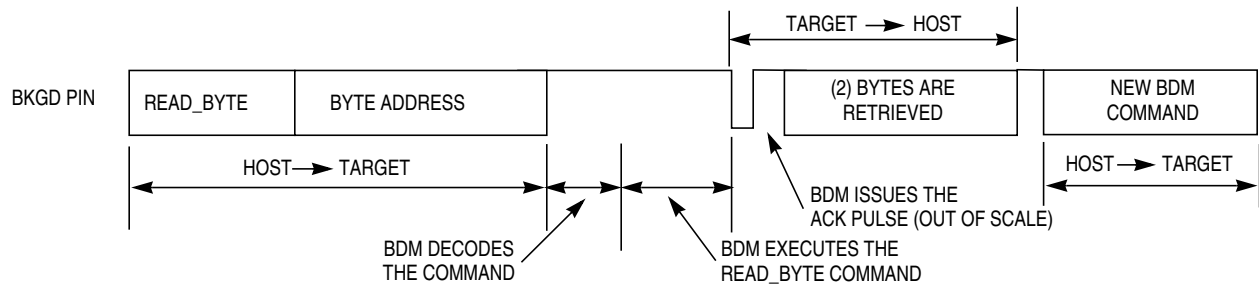

Figure 15-11. Handshake Protocol at Command Level

Differently from the normal bit transfer (where the host initiates the transmission), the serial interface ACK handshake pulse is initiated by the target MCU by issuing a falling edge in the BKGD pin. The hardware handshake protocol in Figure 15-10 specifies the timing when the BKGD pin is being driven, so the host should follow this timing constraint in order to avoid the risk of an electrical conflict in the BKGD pin.

NOTE

The only place the BKGD pin can have an electrical conflict is when one side is driving low and the other side is issuing a speedup pulse (high). Other “highs” are pulled rather than driven. However, at low rates the time of the speedup pulse can become lengthy and so the potential conflict time becomes longer as well.

The ACK handshake protocol does not support nested ACK pulses. If a BDM command is not acknowledge by an ACK pulse, the host needs to abort the pending command first in order to be able to issue a new BDM command. When the CPU enters WAIT or STOP while the host issues a command that requires CPU execution (e.g., WRITE_BYTE), the target discards the incoming command due to the WAIT or STOP being detected. Therefore, the command is not acknowledged by the target, which means that the ACK pulse will not be issued in this case. After a certain time the host should decide to abort the ACK sequence in order to be free to issue a new command. Therefore, the protocol should provide a mechanism in which a command, and therefore a pending ACK, could be aborted.

NOTE

Differently from a regular BDM command, the ACK pulse does not provide a time out. This means that in the case of a WAIT or STOP instruction being executed, the ACK would be prevented from being issued. If not aborted, the ACK would remain pending indefinitely. See the handshake abort procedure described in Section 15.4.8, “Hardware Handshake Abort Procedure.”

15.4.8 Hardware Handshake Abort Procedure

The abort procedure is based on the SYNC command. In order to abort a command, which had not issued the corresponding ACK pulse, the host controller should generate a low pulse in the BKGD pin by driving it low for at least 128 serial clock cycles and then driving it high for one serial clock cycle, providing a speedup pulse. By detecting this long low pulse in the BKGD pin, the target executes the SYNC protocol, see [Section 15.4.9, “SYNC — Request Timed Reference Pulse,”](#) and assumes that the pending command and therefore the related ACK pulse, are being aborted. Therefore, after the SYNC protocol has been completed the host is free to issue new BDM commands.

Although it is not recommended, the host could abort a pending BDM command by issuing a low pulse in the BKGD pin shorter than 128 serial clock cycles, which will not be interpreted as the SYNC command. The ACK is actually aborted when a falling edge is perceived by the target in the BKGD pin. The short abort pulse should have at least 4 clock cycles keeping the BKGD pin low, in order to allow the falling edge to be detected by the target. In this case, the target will not execute the SYNC protocol but the pending command will be aborted along with the ACK pulse. The potential problem with this abort procedure is when there is a conflict between the ACK pulse and the short abort pulse. In this case, the target may not perceive the abort pulse. The worst case is when the pending command is a read command (i.e., READ_BYTE). If the abort pulse is not perceived by the target the host will attempt to send a new command after the abort pulse was issued, while the target expects the host to retrieve the accessed memory byte. In this case, host and target will run out of synchronism. However, if the command to be aborted is not a read command the short abort pulse could be used. After a command is aborted the target assumes the next falling edge, after the abort pulse, is the first bit of a new BDM command.

NOTE

The details about the short abort pulse are being provided only as a reference for the reader to better understand the BDM internal behavior. It is not recommended that this procedure be used in a real application.

Because the host knows the target serial clock frequency, the SYNC command (used to abort a command) does not need to consider the lower possible target frequency. In this case, the host could issue a SYNC very close to the 128 serial clock cycles length. Providing a small overhead on the pulse length in order to assure the SYNC pulse will not be misinterpreted by the target. See [Section 15.4.9, “SYNC — Request Timed Reference Pulse.”](#)

[Figure 15-12](#) shows a SYNC command being issued after a READ_BYTE, which aborts the READ_BYTE command. Note that, after the command is aborted a new command could be issued by the host computer.

NOTE

[Figure 15-12](#) does not represent the signals in a true timing scale

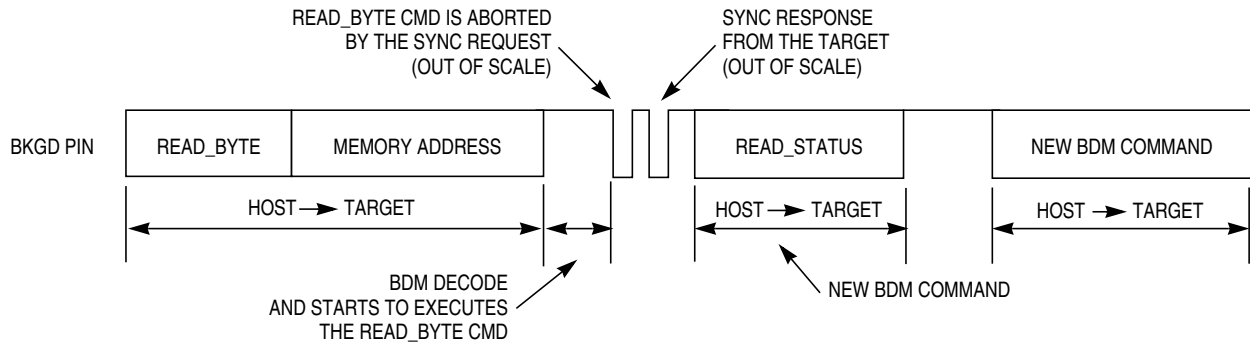

Figure 15-12. ACK Abort Procedure at the Command Level

Figure 15-13 shows a conflict between the ACK pulse and the SYNC request pulse. This conflict could occur if a POD device is connected to the target BKGD pin and the target is already in debug active mode. Consider that the target CPU is executing a pending BDM command at the exact moment the POD is being connected to the BKGD pin. In this case, an ACK pulse is issued along with the SYNC command. In this case, there is an electrical conflict between the ACK speedup pulse and the SYNC pulse. Because this is not a probable situation, the protocol does not prevent this conflict from happening.

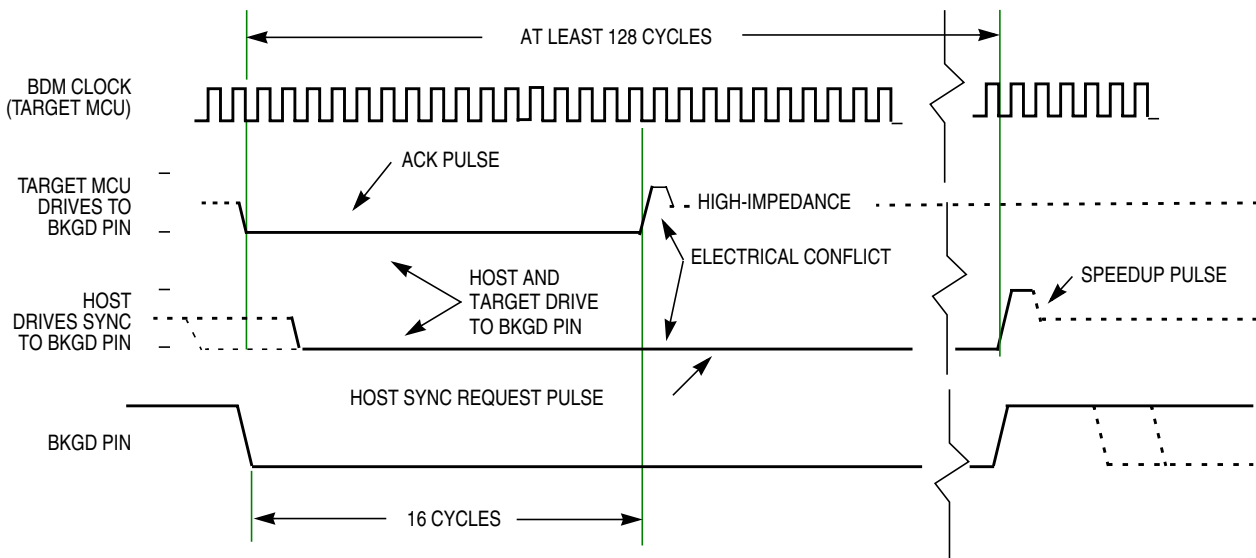

Figure 15-13. ACK Pulse and SYNC Request Conflict

NOTE

This information is being provided so that the MCU integrator will be aware that such a conflict could eventually occur.

The hardware handshake protocol is enabled by the `ACK_ENABLE` and disabled by the `ACK_DISABLE` BDM commands. This provides backwards compatibility with the existing POD devices which are not able to execute the hardware handshake protocol. It also allows for new POD devices, that support the hardware handshake protocol, to freely communicate with the target device. If desired, without the need for waiting for the ACK pulse.

The commands are described as follows:

- **ACK_ENABLE** — enables the hardware handshake protocol. The target will issue the ACK pulse when a CPU command is executed by the CPU. The **ACK_ENABLE** command itself also has the ACK pulse as a response.
- **ACK_DISABLE** — disables the ACK pulse protocol. In this case, the host needs to use the worst case delay time at the appropriate places in the protocol.

The default state of the BDM after reset is hardware handshake protocol disabled.

All the read commands will ACK (if enabled) when the data bus cycle has completed and the data is then ready for reading out by the BKGD serial pin. All the write commands will ACK (if enabled) after the data has been received by the BDM through the BKGD serial pin and when the data bus cycle is complete. See [Section 15.4.3, “BDM Hardware Commands,”](#) and [Section 15.4.4, “Standard BDM Firmware Commands,”](#) for more information on the BDM commands.

The **ACK_ENABLE** sends an ACK pulse when the command has been completed. This feature could be used by the host to evaluate if the target supports the hardware handshake protocol. If an ACK pulse is issued in response to this command, the host knows that the target supports the hardware handshake protocol. If the target does not support the hardware handshake protocol the ACK pulse is not issued. In this case, the **ACK_ENABLE** command is ignored by the target because it is not recognized as a valid command.

The **BACKGROUND** command will issue an ACK pulse when the CPU changes from normal to background mode. The ACK pulse related to this command could be aborted using the **SYNC** command.

The **GO** command will issue an ACK pulse when the CPU exits from background mode. The ACK pulse related to this command could be aborted using the **SYNC** command.

The **GO_UNTIL** command is equivalent to a **GO** command with exception that the ACK pulse, in this case, is issued when the CPU enters into background mode. This command is an alternative to the **GO** command and should be used when the host wants to trace if a breakpoint match occurs and causes the CPU to enter active background mode. Note that the ACK is issued whenever the CPU enters BDM, which could be caused by a breakpoint match or by a **BGND** instruction being executed. The ACK pulse related to this command could be aborted using the **SYNC** command.

The **TRACE1** command has the related ACK pulse issued when the CPU enters background active mode after one instruction of the application program is executed. The ACK pulse related to this command could be aborted using the **SYNC** command.

The **TAGGO** command will not issue an ACK pulse because this would interfere with the tagging function shared on the same pin.

15.4.9 SYNC — Request Timed Reference Pulse

The SYNC command is unlike other BDM commands because the host does not necessarily know the correct communication speed to use for BDM communications until after it has analyzed the response to the SYNC command. To issue a SYNC command, the host should perform the following steps:

1. Drive the BKGD pin low for at least 128 cycles at the lowest possible BDM serial communication frequency (the lowest serial communication frequency is determined by the crystal oscillator or the clock chosen by CLKS_W.)
2. Drive BKGD high for a brief speedup pulse to get a fast rise time (this speedup pulse is typically one cycle of the host clock.)
3. Remove all drive to the BKGD pin so it reverts to high impedance.
4. Listen to the BKGD pin for the sync response pulse.

Upon detecting the SYNC request from the host, the target performs the following steps:

1. Discards any incomplete command received or bit retrieved.
2. Waits for BKGD to return to a logic 1.
3. Delays 16 cycles to allow the host to stop driving the high speedup pulse.
4. Drives BKGD low for 128 cycles at the current BDM serial communication frequency.
5. Drives a one-cycle high speedup pulse to force a fast rise time on BKGD.
6. Removes all drive to the BKGD pin so it reverts to high impedance.

The host measures the low time of this 128 cycle SYNC response pulse and determines the correct speed for subsequent BDM communications. Typically, the host can determine the correct communication speed within a few percent of the actual target speed and the communication protocol can easily tolerate speed errors of several percent.

As soon as the SYNC request is detected by the target, any partially received command or bit retrieved is discarded. This is referred to as a soft-reset, equivalent to a time-out in the serial communication. After the SYNC response, the target will consider the next falling edge (issued by the host) as the start of a new BDM command or the start of new SYNC request.

Another use of the SYNC command pulse is to abort a pending ACK pulse. The behavior is exactly the same as in a regular SYNC command. Note that one of the possible causes for a command to not be acknowledged by the target is a host-target synchronization problem. In this case, the command may not have been understood by the target and so an ACK response pulse will not be issued.

15.4.10 Instruction Tracing

When a TRACE1 command is issued to the BDM in active BDM, the CPU exits the standard BDM firmware and executes a single instruction in the user code. As soon as this has occurred, the CPU is forced to return to the standard BDM firmware and the BDM is active and ready to receive a new command. If the TRACE1 command is issued again, the next user instruction will be executed. This facilitates stepping or tracing through the user code one instruction at a time.

If an interrupt is pending when a TRACE1 command is issued, the interrupt stacking operation occurs but no user instruction is executed. Upon return to standard BDM firmware execution, the program counter points to the first instruction in the interrupt service routine.

15.4.11 Instruction Tagging

The instruction queue and cycle-by-cycle CPU activity are reconstructible in real time or from trace history that is captured by a logic analyzer. However, the reconstructed queue cannot be used to stop the CPU at a specific instruction. This is because execution already has begun by the time an operation is visible outside the system. A separate instruction tagging mechanism is provided for this purpose.

The tag follows program information as it advances through the instruction queue. When a tagged instruction reaches the head of the queue, the CPU enters active BDM rather than executing the instruction.

NOTE

Tagging is disabled when BDM becomes active and BDM serial commands are not processed while tagging is active.

Executing the BDM TAGGO command configures two system pins for tagging. The $\overline{\text{TAGLO}}$ signal shares a pin with the $\overline{\text{LSTRB}}$ signal, and the $\overline{\text{TAGHI}}$ signal shares a pin with the BKGD signal.

Table 15-7 shows the functions of the two tagging pins. The pins operate independently, that is the state of one pin does not affect the function of the other. The presence of logic level 0 on either pin at the fall of the external clock (ECLK) performs the indicated function. High tagging is allowed in all modes. Low tagging is allowed only when low strobe is enabled (LSTRB is allowed only in wide expanded modes and emulation expanded narrow mode).

Table 15-7. Tag Pin Function

$\overline{\text{TAGHI}}$	$\overline{\text{TAGLO}}$	Tag
1	1	No tag
1	0	Low byte
0	1	High byte
0	0	Both bytes

15.4.12 Serial Communication Time-Out

The host initiates a host-to-target serial transmission by generating a falling edge on the BKGD pin. If BKGD is kept low for more than 128 target clock cycles, the target understands that a SYNC command was issued. In this case, the target will keep waiting for a rising edge on BKGD in order to answer the SYNC request pulse. If the rising edge is not detected, the target will keep waiting forever without any time-out limit.

Consider now the case where the host returns BKGD to logic one before 128 cycles. This is interpreted as a valid bit transmission, and not as a SYNC request. The target will keep waiting for another falling edge marking the start of a new bit. If, however, a new falling edge is not detected by the target within 512 clock cycles since the last falling edge, a time-out occurs and the current command is discarded without affecting memory or the operating mode of the MCU. This is referred to as a soft-reset.

If a read command is issued but the data is not retrieved within 512 serial clock cycles, a soft-reset will occur causing the command to be disregarded. The data is not available for retrieval after the time-out has occurred. This is the expected behavior if the handshake protocol is not enabled. However, consider the behavior where the BDC is running in a frequency much greater than the CPU frequency. In this case, the command could time out before the data is ready to be retrieved. In order to allow the data to be retrieved even with a large clock frequency mismatch (between BDC and CPU) when the hardware handshake protocol is enabled, the time out between a read command and the data retrieval is disabled. Therefore, the host could wait for more than 512 serial clock cycles and continue to be able to retrieve the data from an issued read command. However, as soon as the handshake pulse (ACK pulse) is issued, the time-out feature is re-activated, meaning that the target will time out after 512 clock cycles. Therefore, the host needs to retrieve the data within a 512 serial clock cycles time frame after the ACK pulse had been issued. After that period, the read command is discarded and the data is no longer available for retrieval. Any falling edge of the BKGD pin after the time-out period is considered to be a new command or a SYNC request.

Note that whenever a partially issued command, or partially retrieved data, has occurred the time out in the serial communication is active. This means that if a time frame higher than 512 serial clock cycles is observed between two consecutive negative edges and the command being issued or data being retrieved is not complete, a soft-reset will occur causing the partially received command or data retrieved to be disregarded. The next falling edge of the BKGD pin, after a soft-reset has occurred, is considered by the target as the start of a new BDM command, or the start of a SYNC request pulse.

15.4.13 Operation in Wait Mode

The BDM cannot be used in wait mode if the system disables the clocks to the BDM.

There is a clearing mechanism associated with the WAIT instruction when the clocks to the BDM (CPU core platform) are disabled. As the clocks restart from wait mode, the BDM receives a soft reset (clearing any command in progress) and the ACK function will be disabled. This is a change from previous BDM modules.

15.4.14 Operation in Stop Mode

The BDM is completely shutdown in stop mode.

There is a clearing mechanism associated with the STOP instruction. STOP must be enabled and the part must go into stop mode for this to occur. As the clocks restart from stop mode, the BDM receives a soft reset (clearing any command in progress) and the ACK function will be disabled. This is a change from previous BDM modules.

Chapter 16

Debug Module (DBGV1) Block Description

16.1 Introduction

This section describes the functionality of the debug (DBG) sub-block of the HCS12 core platform.

The DBG module is designed to be fully compatible with the existing BKP_HCS12_A module (BKP mode) and furthermore provides an on-chip trace buffer with flexible triggering capability (DBG mode). The DBG module provides for non-intrusive debug of application software. The DBG module is optimized for the HCS12 16-bit architecture.

16.1.1 Features

The DBG module in BKP mode includes these distinctive features:

- Full or dual breakpoint mode
 - Compare on address and data (full)
 - Compare on either of two addresses (dual)
- BDM or SWI breakpoint
 - Enter BDM on breakpoint (BDM)
 - Execute SWI on breakpoint (SWI)
- Tagged or forced breakpoint
 - Break just before a specific instruction will begin execution (TAG)
 - Break on the first instruction boundary after a match occurs (Force)
- Single, range, or page address compares
 - Compare on address (single)
 - Compare on address 256 byte (range)
 - Compare on any 16K page (page)
- At forced breakpoints compare address on read or write
- High and/or low byte data compares
- Comparator C can provide an additional tag or force breakpoint (enhancement for BKP mode)

The DBG in DBG mode includes these distinctive features:

- Three comparators (A, B, and C)
 - Dual mode, comparators A and B used to compare addresses
 - Full mode, comparator A compares address and comparator B compares data
 - Can be used as trigger and/or breakpoint
 - Comparator C used in LOOP1 capture mode or as additional breakpoint
- Four capture modes
 - Normal mode, change-of-flow information is captured based on trigger specification
 - Loop1 mode, comparator C is dynamically updated to prevent redundant change-of-flow storage.
 - Detail mode, address and data for all cycles except program fetch (P) and free (f) cycles are stored in trace buffer
 - Profile mode, last instruction address executed by CPU is returned when trace buffer address is read
- Two types of breakpoint or debug triggers
 - Break just before a specific instruction will begin execution (tag)
 - Break on the first instruction boundary after a match occurs (force)
- BDM or SWI breakpoint
 - Enter BDM on breakpoint (BDM)
 - Execute SWI on breakpoint (SWI)
- Nine trigger modes for comparators A and B
 - A
 - A or B
 - A then B
 - A and B, where B is data (full mode)
 - A and not B, where B is data (full mode)
 - Event only B, store data
 - A then event only B, store data
 - Inside range, $A \leq \text{address} \leq B$
 - Outside range, $\text{address} < A$ or $\text{address} > B$
- Comparator C provides an additional tag or force breakpoint when capture mode is not configured in LOOP1 mode.
- Sixty-four word (16 bits wide) trace buffer for storing change-of-flow information, event only data and other bus information.
 - Source address of taken conditional branches (long, short, bit-conditional, and loop constructs)
 - Destination address of indexed JMP, JSR, and CALL instruction.
 - Destination address of RTI, RTS, and RTC instructions
 - Vector address of interrupts, except for SWI and BDM vectors

- Data associated with event B trigger modes
- Detail report mode stores address and data for all cycles except program (P) and free (f) cycles
- Current instruction address when in profiling mode
- BGND is not considered a change-of-flow (cof) by the debugger

16.1.2 Modes of Operation

There are two main modes of operation: breakpoint mode and debug mode. Each one is mutually exclusive of the other and selected via a software programmable control bit.

In the breakpoint mode there are two sub-modes of operation:

- Dual address mode, where a match on either of two addresses will cause the system to enter background debug mode (BDM) or initiate a software interrupt (SWI).
- Full breakpoint mode, where a match on address and data will cause the system to enter background debug mode (BDM) or initiate a software interrupt (SWI).

In debug mode, there are several sub-modes of operation.

- Trigger modes

There are many ways to create a logical trigger. The trigger can be used to capture bus information either starting from the trigger or ending at the trigger. Types of triggers (A and B are registers):

- A only
- A or B
- A then B
- Event only B (data capture)
- A then event only B (data capture)
- A and B, full mode
- A and not B, full mode
- Inside range
- Outside range

- Capture modes

There are several capture modes. These determine which bus information is saved and which is ignored.

- Normal: save change-of-flow program fetches
- Loop1: save change-of-flow program fetches, ignoring duplicates
- Detail: save all bus operations except program and free cycles
- Profile: poll target from external device

16.1.3 Block Diagram

Figure 16-1 is a block diagram of this module in breakpoint mode. Figure 16-2 is a block diagram of this module in debug mode.

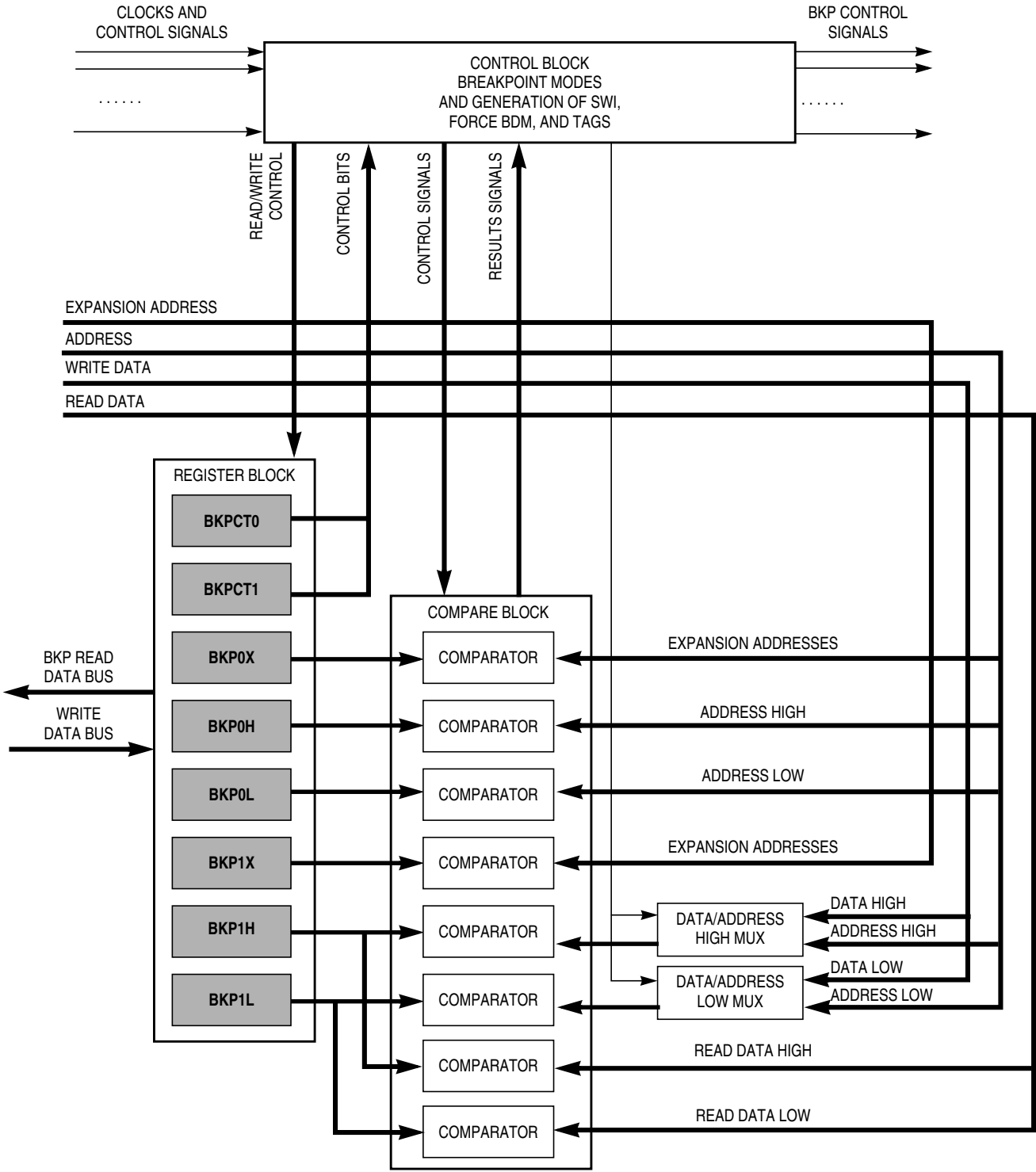

Figure 16-1. DBG Block Diagram in BKP Mode

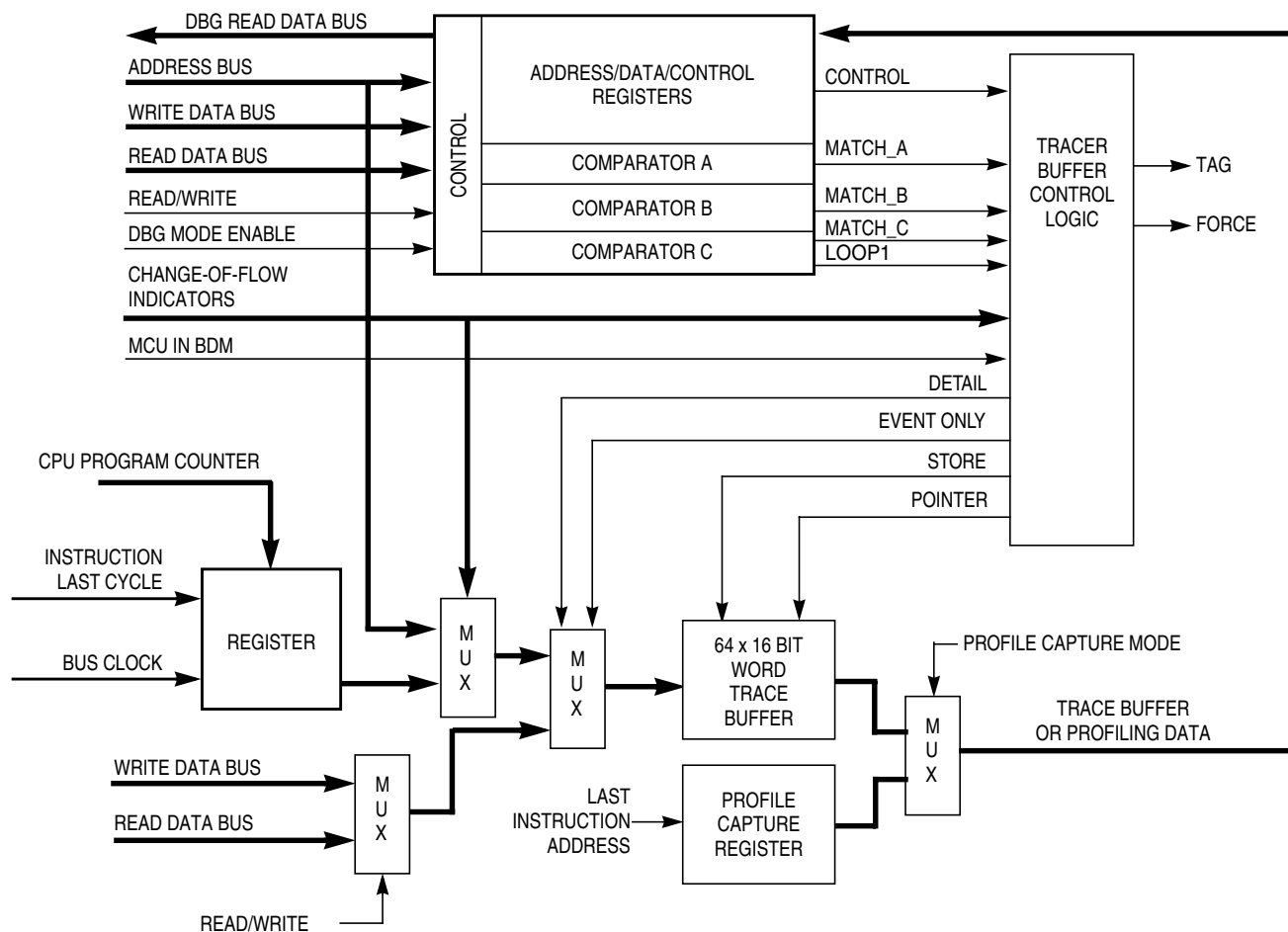

Figure 16-2. DBG Block Diagram in DBG Mode

16.2 External Signal Description

The DBG sub-module relies on the external bus interface (generally the MEBI) when the DBG is matching on the external bus.

The tag pins in [Table 16-1](#) (part of the MEBI) may also be a part of the breakpoint operation.

Table 16-1. External System Pins Associated with DBG and MEBI

Pin Name	Pin Functions	Description
BKGD/MODC/ TAGHI	$\overline{\text{TAGHI}}$	When instruction tagging is on, a 0 at the falling edge of E tags the high half of the instruction word being read into the instruction queue.
PE3/LSTRB/ TAGLO	$\overline{\text{TAGLO}}$	In expanded wide mode or emulation narrow modes, when instruction tagging is on and low strobe is enabled, a 0 at the falling edge of E tags the low half of the instruction word being read into the instruction queue.

16.3 Memory Map and Register Definition

A summary of the registers associated with the DBG sub-block is shown in [Figure 16-3](#). Detailed descriptions of the registers and bits are given in the subsections that follow.

16.3.1 Module Memory Map

Table 16-2. DBGV1 Memory Map

Address Offset	Use	Access
0x0020	Debug Control Register (DBGC1)	R/W
0x0021	Debug Status and Control Register (DBGSC)	R/W
0x0022	Debug Trace Buffer Register High (DBGTBH)	R
0x0023	Debug Trace Buffer Register Low (DBGTBL)	R
0x0024	Debug Count Register (DBGCNT)	R
0x0025	Debug Comparator C Extended Register (DBGCCX)	R/W
0x0026	Debug Comparator C Register High (DBGCCCH)	R/W
0x0027	Debug Comparator C Register Low (DBGCCCL)	R/W
0x0028	Debug Control Register 2 (DBGC2) / (BKPCT0)	R/W
0x0029	Debug Control Register 3 (DBGC3) / (BKPCT1)	R/W
0x002A	Debug Comparator A Extended Register (DBGCAx) / (/BKP0x)	R/W
0x002B	Debug Comparator A Register High (DBGCAH) / (BKP0H)	R/W
0x002C	Debug Comparator A Register Low (DBGCAL) / (BKP0L)	R/W
0x002D	Debug Comparator B Extended Register (DBGCBx) / (BKP1x)	R/W
0x002E	Debug Comparator B Register High (DBGCBH) / (BKP1H)	R/W
0x002F	Debug Comparator B Register Low (DBGCBL) / (BKP1L)	R/W

16.3.2 Register Descriptions

This section consists of the DBG register descriptions in address order. Most of the register bits can be written to in either BKP or DBG mode, although they may not have any effect in one of the modes. However, the only bits in the DBG module that can be written while the debugger is armed (ARM = 1) are DBGEN and ARM

Name ¹	Bit 7	6	5	4	3	2	1	Bit 0
0x0020 DBGC1	R W DBGEN	ARM	TRGSEL	BEGIN	DBGBRK	0		CAPMOD
0x0021 DBGSC	R W AF	BF	CF	0		TRG		

= Unimplemented or Reserved

Figure 16-3. DBG Register Summary

Name ¹		Bit 7	6	5	4	3	2	1	Bit 0
0x0022 DBGTBH	R	Bit 15	Bit 14	Bit 13	Bit 12	Bit 11	Bit 10	Bit 9	Bit 8
	W								
0x0023 DBGTBL	R	Bit 7	Bit 6	Bit 5	Bit 4	Bit 3	Bit 2	Bit 1	Bit 0
	W								
0x0024 DBGCNT	R	TBF	0	CNT					
	W								
0x0025 DBGCCX ⁽²⁾	R	PAGSEL			EXTCMP				
	W								
0x0026 DBGCCCH ⁽²⁾	R	Bit 15	14	13	12	11	10	9	Bit 8
	W								
0x0027 DBGCCCL ⁽²⁾	R	Bit 7	6	5	4	3	2	1	Bit 0
	W								
0x0028 DBGC2 BKPCT0	R	BKABEN	FULL	BDM	TAGAB	BKCEN	TAGC	RWCEN	RWC
	W								
0x0029 DBGC3 BKPCT1	R	BKAMBH	BKAMBL	BKBMBH	BKBMBL	RWAEN	RWA	RWBEN	RWB
	W								
0x002A DBGCA BKP0X	R	PAGSEL			EXTCMP				
	W								
0x002B DBGCAH BKP0H	R	Bit 15	14	13	12	11	10	9	Bit 8
	W								
0x002C DBGCAL BKP0L	R	Bit 7	6	5	4	3	2	1	Bit 0
	W								
0x002D DBGCBX BKP1X	R	PAGSEL			EXTCMP				
	W								
0x002E DBGCBH BKP1H	R	Bit 15	14	13	12	11	10	9	Bit 8
	W								
0x002F DBGCBL BKP1L	R	Bit 7	6	5	4	3	2	1	Bit 0
	W								

= Unimplemented or Reserved

Figure 16-3. DBG Register Summary (continued)

- ¹ The DBG module is designed for backwards compatibility to existing BKP modules. Register and bit names have changed from the BKP module. This column shows the DBG register name, as well as the BKP register name for reference.
- ² Comparator C can be used to enhance the BKP mode by providing a third breakpoint.

16.3.2.1 Debug Control Register 1 (DBGC1)

NOTE

All bits are used in DBG mode only.

Module Base + 0x0020

Starting address location affected by INITRG register setting.

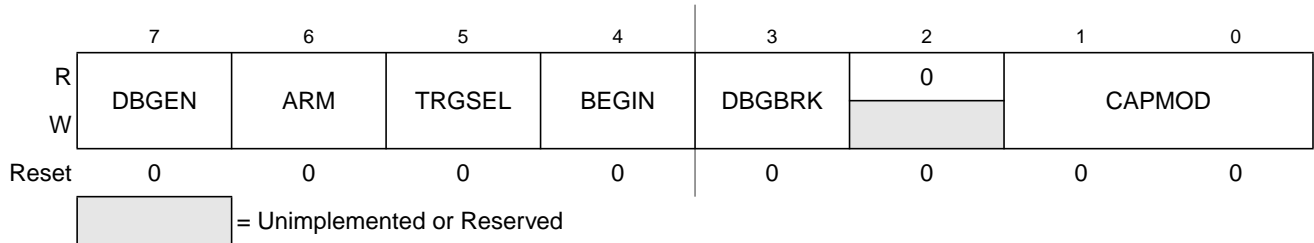

Figure 16-4. Debug Control Register (DBGC1)

NOTE

This register cannot be written if BKP mode is enabled (BKABEN in DBGC2 is set).

Table 16-3. DBGC1 Field Descriptions

Field	Description
7 DBGEN	<p>DBG Mode Enable Bit — The DBGEN bit enables the DBG module for use in DBG mode. This bit cannot be set if the MCU is in secure mode.</p> <p>0 DBG mode disabled 1 DBG mode enabled</p>
6 ARM	<p>Arm Bit — The ARM bit controls whether the debugger is comparing and storing data in the trace buffer. See Section 16.4.2.4, “Arming the DBG Module,” for more information.</p> <p>0 Debugger unarmed 1 Debugger armed</p> <p>Note: This bit cannot be set if the DBGEN bit is not also being set at the same time. For example, a write of 01 to DBGEN[7:6] will be interpreted as a write of 00.</p>
5 TRGSEL	<p>Trigger Selection Bit — The TRGSEL bit controls the triggering condition for comparators A and B in DBG mode. It serves essentially the same function as the TAGAB bit in the DBGC2 register does in BKP mode. See Section 16.4.2.1.2, “Trigger Selection,” for more information. TRGSEL may also determine the type of breakpoint based on comparator A and B if enabled in DBG mode (DBGBRK = 1). Please refer to Section 16.4.3.1, “Breakpoint Based on Comparator A and B.”</p> <p>0 Trigger on any compare address match 1 Trigger before opcode at compare address gets executed (tagged-type)</p>

Table 16-3. DBGC1 Field Descriptions (continued)

Field	Description
4 BEGIN	<p>Begin/End Trigger Bit — The BEGIN bit controls whether the trigger begins or ends storing of data in the trace buffer. See Section 16.4.2.8.1, “Storing with Begin-Trigger,” and Section 16.4.2.8.2, “Storing with End-Trigger,” for more details.</p> <p>0 Trigger at end of stored data 1 Trigger before storing data</p>
3 DBGBRK	<p>DBG Breakpoint Enable Bit — The DBGBRK bit controls whether the debugger will request a breakpoint based on comparator A and B to the CPU upon completion of a tracing session. Please refer to Section 16.4.3, “Breakpoints,” for further details.</p> <p>0 CPU break request not enabled 1 CPU break request enabled</p>
1:0 CAPMOD	<p>Capture Mode Field — See Table 16-4 for capture mode field definitions. In LOOP1 mode, the debugger will automatically inhibit redundant entries into capture memory. In detail mode, the debugger is storing address and data for all cycles except program fetch (P) and free (f) cycles. In profile mode, the debugger is returning the address of the last instruction executed by the CPU on each access of trace buffer address. Refer to Section 16.4.2.6, “Capture Modes,” for more information.</p>

Table 16-4. CAPMOD Encoding

CAPMOD	Description
00	Normal
01	LOOP1
10	DETAIL
11	PROFILE

16.3.2.2 Debug Status and Control Register (DBGSC)

Module Base + 0x0021

Starting address location affected by INITRG register setting.

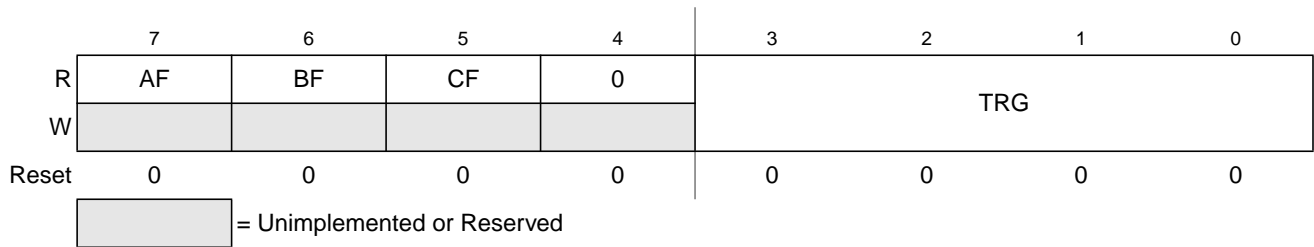

Figure 16-5. Debug Status and Control Register (DBGSC)

Table 16-5. DBGSC Field Descriptions

Field	Description
7 AF	Trigger A Match Flag — The AF bit indicates if trigger A match condition was met since arming. This bit is cleared when ARM in DBGSC1 is written to a 1 or on any write to this register. 0 Trigger A did not match 1 Trigger A match
6 BF	Trigger B Match Flag — The BF bit indicates if trigger B match condition was met since arming. This bit is cleared when ARM in DBGSC1 is written to a 1 or on any write to this register. 0 Trigger B did not match 1 Trigger B match
5 CF	Comparator C Match Flag — The CF bit indicates if comparator C match condition was met since arming. This bit is cleared when ARM in DBGSC1 is written to a 1 or on any write to this register. 0 Comparator C did not match 1 Comparator C match
3:0 TRG	Trigger Mode Bits — The TRG bits select the trigger mode of the DBG module as shown Table 16-6 . See Section 16.4.2.5, "Trigger Modes," for more detail.

Table 16-6. Trigger Mode Encoding

TRG Value	Meaning
0000	A only
0001	A or B
0010	A then B
0011	Event only B
0100	A then event only B
0101	A and B (full mode)
0110	A and Not B (full mode)
0111	Inside range
1000	Outside range
1001 ↓ 1111	Reserved (Defaults to A only)

16.3.2.3 Debug Trace Buffer Register (DBGTB)

Module Base + 0x0022

Starting address location affected by INITRG register setting.

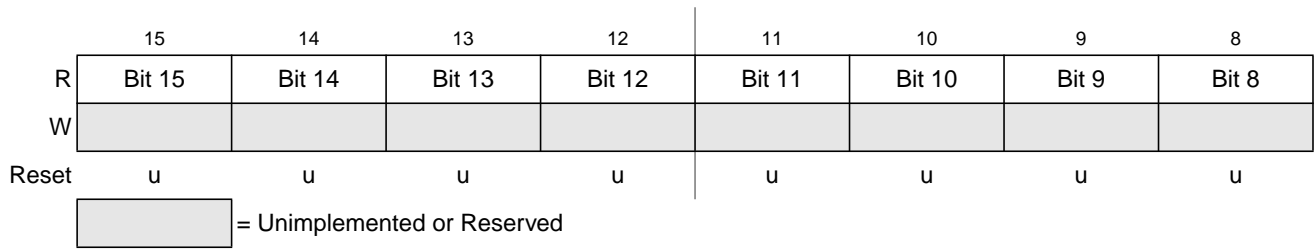

Figure 16-6. Debug Trace Buffer Register High (DBGTBH)

Module Base + 0x0023

Starting address location affected by INITRG register setting.

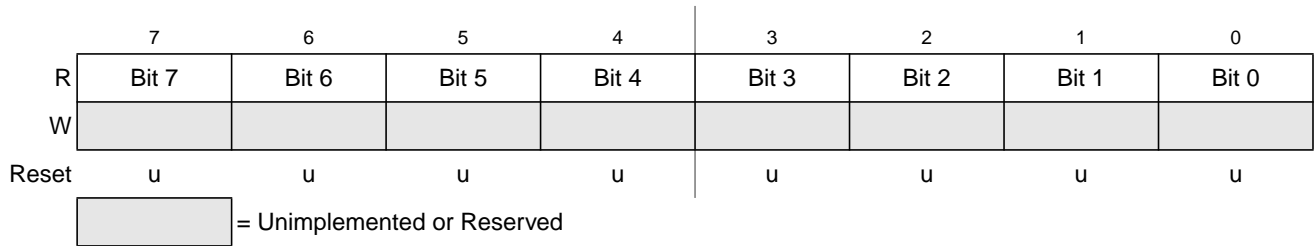

Figure 16-7. Debug Trace Buffer Register Low (DBGTBL)

Table 16-7. DBGTB Field Descriptions

Field	Description
15:0	Trace Buffer Data Bits — The trace buffer data bits contain the data of the trace buffer. This register can be read only as a word read. Any byte reads or misaligned access of these registers will return 0 and will not cause the trace buffer pointer to increment to the next trace buffer address. The same is true for word reads while the debugger is armed. In addition, this register may appear to contain incorrect data if it is not read with the same capture mode bit settings as when the trace buffer data was recorded (See Section 16.4.2.9, “Reading Data from Trace Buffer”). Because reads will reflect the contents of the trace buffer RAM, the reset state is undefined.

16.3.2.4 Debug Count Register (DBGCNT)

Module Base + 0x0024

Starting address location affected by INITRG register setting.

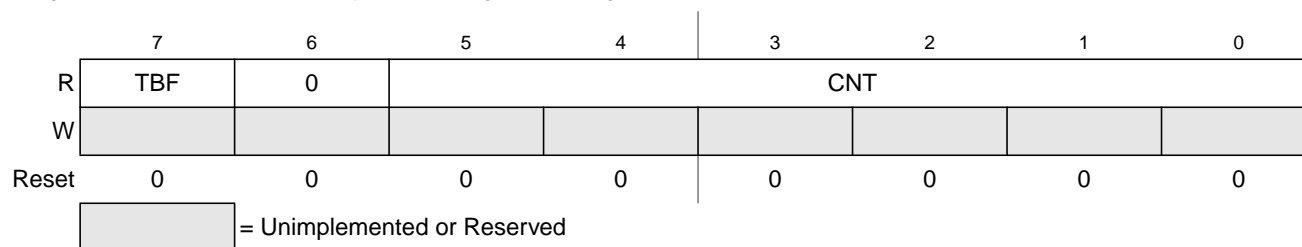

Figure 16-8. Debug Count Register (DBGCNT)

Table 16-8. DBG CNT Field Descriptions

Field	Description
7 TBF	Trace Buffer Full — The TBF bit indicates that the trace buffer has stored 64 or more words of data since it was last armed. If this bit is set, then all 64 words will be valid data, regardless of the value in CNT[5:0]. The TBF bit is cleared when ARM in DBG C1 is written to a 1.
5:0 CNT	Count Value — The CNT bits indicate the number of valid data words stored in the trace buffer. Table 16-9 shows the correlation between the CNT bits and the number of valid data words in the trace buffer. When the CNT rolls over to 0, the TBF bit will be set and incrementing of CNT will continue if DBG is in end-trigger mode. The DBG CNT register is cleared when ARM in DBG C1 is written to a 1.

Table 16-9. CNT Decoding Table

TBF	CNT	Description
0	000000	No data valid
0	000001	1 word valid
0	000010	2 words valid

	111110	62 words valid
0	111111	63 words valid
1	000000	64 words valid; if BEGIN = 1, the ARM bit will be cleared. A breakpoint will be generated if DBGBRK = 1
1	000001	64 words valid, oldest data has been overwritten by most recent data
	..	
	..	
	111111	

16.3.2.5 Debug Comparator C Extended Register (DBGCCX)

Module Base + 0x0025

Starting address location affected by INITRG register setting.

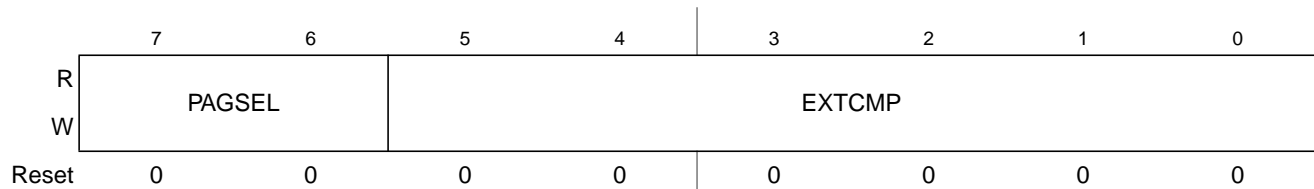

Figure 16-9. Debug Comparator C Extended Register (DBGCCX)

Table 16-10. DBGCCX Field Descriptions

Field	Description
7:6 PAGSEL	Page Selector Field — In both BKP and DBG mode, PAGSEL selects the type of paging as shown in Table 16-11 . DPAGE and EPAGE are not yet implemented so the value in bit 7 will be ignored (i.e., PAGSEL values of 10 and 11 will be interpreted as values of 00 and 01, respectively).
5:0 EXTCMP	Comparator C Extended Compare Bits — The EXTCMP bits are used as comparison address bits as shown in Table 16-11 along with the appropriate PPAGE, DPAGE, or EPAGE signal from the core. Note: Comparator C can be used when the DBG module is configured for BKP mode. Extended addressing comparisons for comparator C use PAGSEL and will operate differently to the way that comparator A and B operate in BKP mode.

Table 16-11. PAGSEL Decoding¹

PAGSEL	Description	EXTCMP	Comment
00	Normal (64k)	Not used	No paged memory
01	PPAGE (256 — 16K pages)	EXTCMP[5:0] is compared to address bits [21:16] ²	PPAGE[7:0] / XAB[21:14] becomes address bits [21:14] ¹
10 ³	DPAGE (reserved) (256 — 4K pages)	EXTCMP[3:0] is compared to address bits [19:16]	DPAGE / XAB[21:14] becomes address bits [19:12]
11 ²	EPAGE (reserved) (256 — 1K pages)	EXTCMP[1:0] is compared to address bits [17:16]	EPAGE / XAB[21:14] becomes address bits [17:10]

¹ See [Figure 16-10](#).

² Current HCS12 implementations have PPAGE limited to 6 bits. Therefore, EXTCMP[5:4] should be set to 00.

³ Data page (DPAGE) and Extra page (EPAGE) are reserved for implementation on devices that support paged data and extra space.

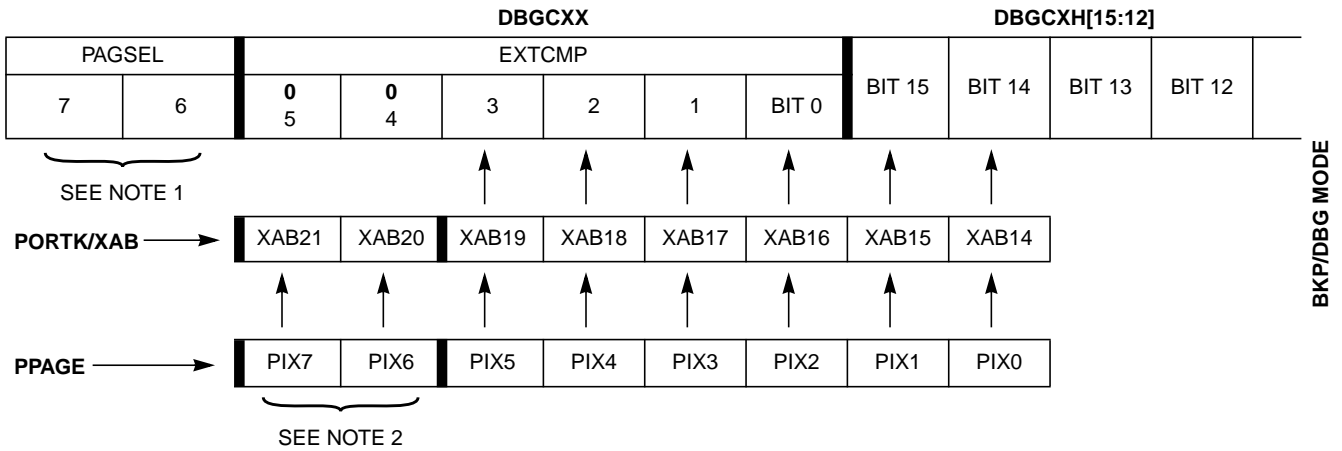

- NOTES:
1. In BKP and DBG mode, PAGSEL selects the type of paging as shown in [Table 16-11](#).
 2. Current HCS12 implementations are limited to six PPAGE bits, PIX[5:0]. Therefore, EXT_CMP[5:4] = 00.

Figure 16-10. Comparator C Extended Comparison in BKP/DBG Mode

16.3.2.6 Debug Comparator C Register (DBGCC)

Module Base + 0x0026

Starting address location affected by INITRG register setting.

	15	14	13	12	11	10	9	8
R	Bit 15	Bit 14	Bit 13	Bit 12	Bit 11	Bit 10	Bit 9	Bit 8
W								
Reset	0	0	0	0	0	0	0	0

= Unimplemented or Reserved

Figure 16-11. Debug Comparator C Register High (DBGCCH)

Module Base + 0x0027

Starting address location affected by INITRG register setting.

	7	6	5	4	3	2	1	0
R	Bit 7	Bit 6	Bit 5	Bit 4	Bit 3	Bit 2	Bit 1	Bit 0
W								
Reset	0	0	0	0	0	0	0	0

= Unimplemented or Reserved

Figure 16-12. Debug Comparator C Register Low (DBGCCCL)

Table 16-12. DBGCC Field Descriptions

Field	Description
15:0	<p>Comparator C Compare Bits — The comparator C compare bits control whether comparator C will compare the address bus bits [15:0] to a logic 1 or logic 0. See Table 16-13.</p> <p>0 Compare corresponding address bit to a logic 0</p> <p>1 Compare corresponding address bit to a logic 1</p> <p>Note: This register will be cleared automatically when the DBG module is armed in LOOP1 mode.</p>

Table 16-13. Comparator C Compares

PAGSEL	EXTCMP Compare	High-Byte Compare
x0	No compare	DBGCCCH[7:0] = AB[15:8]
x1	EXTCMP[5:0] = XAB[21:16]	DBGCCCH[7:0] = XAB[15:14],AB[13:8]

16.3.2.7 Debug Control Register 2 (DBGC2)

Module Base + 0x0028

Starting address location affected by INITRG register setting.

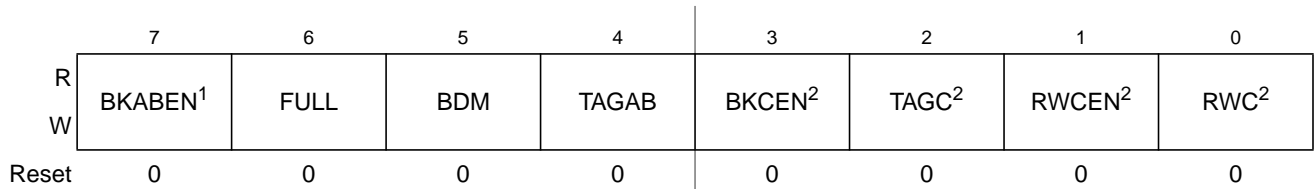

- ¹ When BKABEN is set (BKP mode), all bits in DBGC2 are available. When BKABEN is cleared and DBG is used in DBG mode, bits FULL and TAGAB have no meaning.
- ² These bits can be used in BKP mode and DBG mode (when capture mode is not set in LOOP1) to provide a third breakpoint.

Figure 16-13. Debug Control Register 2 (DBGC2)

Table 16-14. DBGC2 Field Descriptions

Field	Description
7 BKABEN	<p>Breakpoint Using Comparator A and B Enable — This bit enables the breakpoint capability using comparator A and B, when set (BKP mode) the DBGGEN bit in DBGCC1 cannot be set.</p> <p>0 Breakpoint module off</p> <p>1 Breakpoint module on</p>
6 FULL	<p>Full Breakpoint Mode Enable — This bit controls whether the breakpoint module is in dual mode or full mode. In full mode, comparator A is used to match address and comparator B is used to match data. See Section 16.4.1.2, “Full Breakpoint Mode,” for more details.</p> <p>0 Dual address mode enabled</p> <p>1 Full breakpoint mode enabled</p>
5 BDM	<p>Background Debug Mode Enable — This bit determines if the breakpoint causes the system to enter background debug mode (BDM) or initiate a software interrupt (SWI).</p> <p>0 Go to software interrupt on a break request</p> <p>1 Go to BDM on a break request</p>

Table 16-14. DBGC2 Field Descriptions (continued)

Field	Description
4 TAGAB	Comparator A/B Tag Select — This bit controls whether the breakpoint will cause a break on the next instruction boundary (force) or on a match that will be an executable opcode (tagged). Non-executed opcodes cannot cause a tagged breakpoint. 0 On match, break at the next instruction boundary (force) 1 On match, break if/when the instruction is about to be executed (tagged)
3 BKCEN	Breakpoint Comparator C Enable Bit — This bit enables the breakpoint capability using comparator C. 0 Comparator C disabled for breakpoint 1 Comparator C enabled for breakpoint Note: This bit will be cleared automatically when the DBG module is armed in loop1 mode.
2 TAGC	Comparator C Tag Select — This bit controls whether the breakpoint will cause a break on the next instruction boundary (force) or on a match that will be an executable opcode (tagged). Non-executed opcodes cannot cause a tagged breakpoint. 0 On match, break at the next instruction boundary (force) 1 On match, break if/when the instruction is about to be executed (tagged)
1 RWCEN	Read/Write Comparator C Enable Bit — The RWCEN bit controls whether read or write comparison is enabled for comparator C. RWCEN is not useful for tagged breakpoints. 0 Read/Write is not used in comparison 1 Read/Write is used in comparison
0 RWC	Read/Write Comparator C Value Bit — The RWC bit controls whether read or write is used in compare for comparator C. The RWC bit is not used if RWCEN = 0. 0 Write cycle will be matched 1 Read cycle will be matched

16.3.2.8 Debug Control Register 3 (DBGC3)

Module Base + 0x0029

Starting address location affected by INITRG register setting.

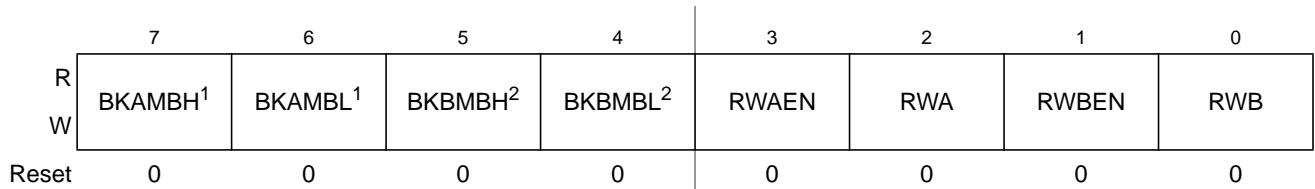

¹ In DBG mode, BKAMBH:BKAMBL has no meaning and are forced to 0's.

² In DBG mode, BKBMBH:BKBMBL are used in full mode to qualify data.

Figure 16-14. Debug Control Register 3 (DBGC3)

Table 16-15. DBG3 Field Descriptions

Field	Description
7:6 BKAMB[H:L]	<p>Breakpoint Mask High Byte for First Address — In dual or full mode, these bits may be used to mask (disable) the comparison of the high and/or low bytes of the first address breakpoint. The functionality is as given in Table 16-16.</p> <p>The x:0 case is for a full address compare. When a program page is selected, the full address compare will be based on bits for a 20-bit compare. The registers used for the compare are {DBGCAH[5:0], DBGCAL[7:0]}, where DBGCAH[5:0] corresponds to PPAGE[5:0] or extended address bits [19:14] and CPU address [13:0]. When a program page is not selected, the full address compare will be based on bits for a 16-bit compare. The registers used for the compare are {DBGCAH[7:0], DBGCAL[7:0]} which corresponds to CPU address [15:0].</p> <p>Note: This extended address compare scheme causes an aliasing problem in BKP mode in which several physical addresses may match with a single logical address. This problem may be avoided by using DBG mode to generate breakpoints.</p> <p>The 1:0 case is not sensible because it would ignore the high order address and compare the low order and expansion addresses. Logic forces this case to compare all address lines (effectively ignoring the BKAMBH control bit).</p> <p>The 1:1 case is useful for triggering a breakpoint on any access to a particular expansion page. This only makes sense if a program page is being accessed so that the breakpoint trigger will occur only if DBGCAH compares.</p>
5:4 BKMB[H:L]	<p>Breakpoint Mask High Byte and Low Byte of Data (Second Address) — In dual mode, these bits may be used to mask (disable) the comparison of the high and/or low bytes of the second address breakpoint. The functionality is as given in Table 16-17.</p> <p>The x:0 case is for a full address compare. When a program page is selected, the full address compare will be based on bits for a 20-bit compare. The registers used for the compare are {DBGCBH[5:0], DBGCBL[7:0]} where DBGCBH[5:0] corresponds to PPAGE[5:0] or extended address bits [19:14] and CPU address [13:0]. When a program page is not selected, the full address compare will be based on bits for a 16-bit compare. The registers used for the compare are {DBGCBH[7:0], DBGCBL[7:0]} which corresponds to CPU address [15:0].</p> <p>Note: This extended address compare scheme causes an aliasing problem in BKP mode in which several physical addresses may match with a single logical address. This problem may be avoided by using DBG mode to generate breakpoints.</p> <p>The 1:0 case is not sensible because it would ignore the high order address and compare the low order and expansion addresses. Logic forces this case to compare all address lines (effectively ignoring the BKMBH control bit).</p> <p>The 1:1 case is useful for triggering a breakpoint on any access to a particular expansion page. This only makes sense if a program page is being accessed so that the breakpoint trigger will occur only if DBGCBH compares.</p> <p>In full mode, these bits may be used to mask (disable) the comparison of the high and/or low bytes of the data breakpoint. The functionality is as given in Table 16-18.</p>
3 RWAEN	<p>Read/Write Comparator A Enable Bit — The RWAEN bit controls whether read or write comparison is enabled for comparator A. See Section 16.4.2.1.1, “Read or Write Comparison,” for more information. This bit is not useful for tagged operations.</p> <p>0 Read/Write is not used in comparison 1 Read/Write is used in comparison</p>
2 RWA	<p>Read/Write Comparator A Value Bit — The RWA bit controls whether read or write is used in compare for comparator A. The RWA bit is not used if RWAEN = 0.</p> <p>0 Write cycle will be matched 1 Read cycle will be matched</p>

Table 16-15. DBG3 Field Descriptions (continued)

Field	Description
1 RWBEN	Read/Write Comparator B Enable Bit — The RWBEN bit controls whether read or write comparison is enabled for comparator B. See Section 16.4.2.1.1, “Read or Write Comparison,” for more information. This bit is not useful for tagged operations. 0 Read/Write is not used in comparison 1 Read/Write is used in comparison
0 RWB	Read/Write Comparator B Value Bit — The RWB bit controls whether read or write is used in compare for comparator B. The RWB bit is not used if RWBEN = 0. 0 Write cycle will be matched 1 Read cycle will be matched Note: RWB and RWBEN are not used in full mode.

Table 16-16. Breakpoint Mask Bits for First Address

BKAMBH:BKAMBL	Address Compare	DBGCAx	DBGCAH	DBGCAL
x:0	Full address compare	Yes ¹	Yes	Yes
0:1	256 byte address range	Yes ¹	Yes	No
1:1	16K byte address range	Yes ¹	No	No

¹ If PPAGE is selected.

Table 16-17. Breakpoint Mask Bits for Second Address (Dual Mode)

BKBMBH:BKBMBL	Address Compare	DBGCBx	DBGCBH	DBGCBL
x:0	Full address compare	Yes ¹	Yes	Yes
0:1	256 byte address range	Yes ¹	Yes	No
1:1	16K byte address range	Yes ¹	No	No

¹ If PPAGE is selected.

Table 16-18. Breakpoint Mask Bits for Data Breakpoints (Full Mode)

BKBMBH:BKBMBL	Data Compare	DBGCBx	DBGCBH	DBGCBL
0:0	High and low byte compare	No ¹	Yes	Yes
0:1	High byte	No ¹	Yes	No
1:0	Low byte	No ¹	No	Yes
1:1	No compare	No ¹	No	No

¹ Expansion addresses for breakpoint B are not applicable in this mode.

16.3.2.9 Debug Comparator A Extended Register (DBGCAx)

Module Base + 0x002A

Starting address location affected by INITRG register setting.

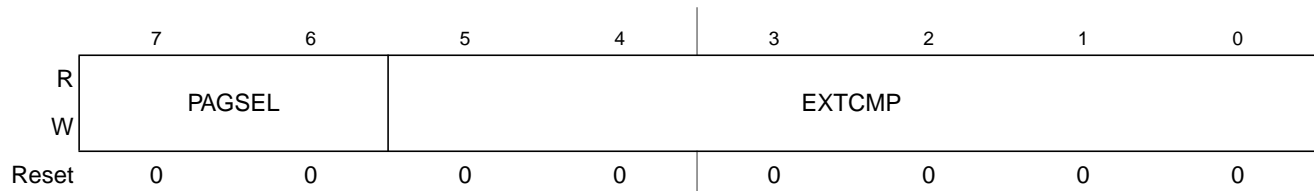

Figure 16-15. Debug Comparator A Extended Register (DBGCAx)

Table 16-19. DBGCAx Field Descriptions

Field	Description
7:6 PAGSEL	<p>Page Selector Field — If DBGGEN is set in DBGCA1, then PAGSEL selects the type of paging as shown in Table 16-20.</p> <p>DPAGE and EPAGE are not yet implemented so the value in bit 7 will be ignored (i.e., PAGSEL values of 10 and 11 will be interpreted as values of 00 and 01, respectively).</p> <p>In BKP mode, PAGSEL has no meaning and EXTCMP[5:0] are compared to address bits [19:14] if the address is in the FLASH/ROM memory space.</p>
5:0 EXTCMP	<p>Comparator A Extended Compare Bits — The EXTCMP bits are used as comparison address bits as shown in Table 16-20 along with the appropriate PPAGE, DPAGE, or EPAGE signal from the core.</p>

Table 16-20. Comparator A or B Compares

Mode		EXTCMP Compare	High-Byte Compare
BKP ¹	Not FLASH/ROM access	No compare	DBGCAxH[7:0] = AB[15:8]
	FLASH/ROM access	EXTCMP[5:0] = XAB[19:14]	DBGCAxH[5:0] = AB[13:8]
DBG ²	PAGSEL = 00	No compare	DBGCAxH[7:0] = AB[15:8]
	PAGSEL = 01	EXTCMP[5:0] = XAB[21:16]	DBGCAxH[7:0] = XAB[15:14], AB[13:8]

¹ See [Figure 16-16](#).

² See [Figure 16-10](#) (note that while this figure provides extended comparisons for comparator C, the figure also pertains to comparators A and B in DBG mode only).

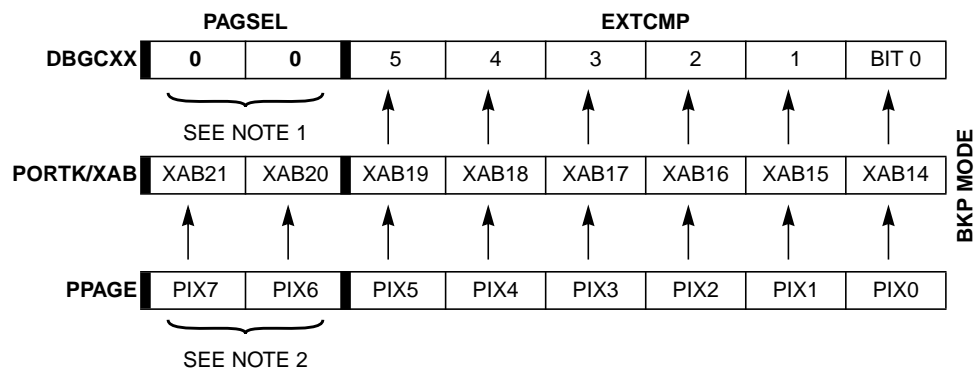

NOTES:

1. In BKP mode, PAGSEL has no functionality. Therefore, set PAGSEL to 00 (reset state).
2. Current HCS12 implementations are limited to six PPAGE bits, PIX[5:0].

Figure 16-16. Comparators A and B Extended Comparison in BKP Mode

16.3.2.10 Debug Comparator A Register (DBGCA)

Module Base + 0x002B

Starting address location affected by INITRG register setting.

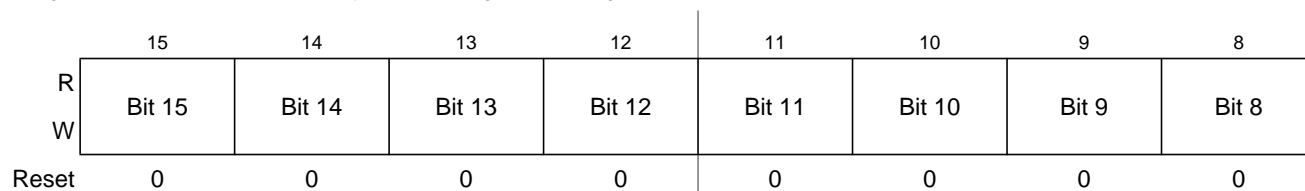

Figure 16-17. Debug Comparator A Register High (DBGCAH)

Module Base + 0x002C

Starting address location affected by INITRG register setting.

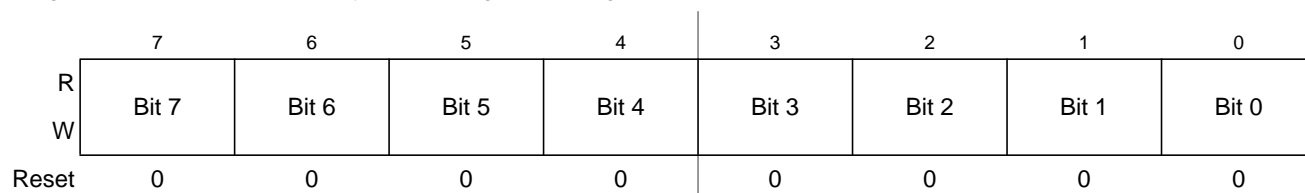

Figure 16-18. Debug Comparator A Register Low (DBGCAL)

Table 16-21. DBGCA Field Descriptions

Field	Description
15:0 15:0	Comparator A Compare Bits — The comparator A compare bits control whether comparator A compares the address bus bits [15:0] to a logic 1 or logic 0. See Table 16-20 . 0 Compare corresponding address bit to a logic 0 1 Compare corresponding address bit to a logic 1

16.3.2.11 Debug Comparator B Extended Register (DBGCBX)

Module Base + 0x002D

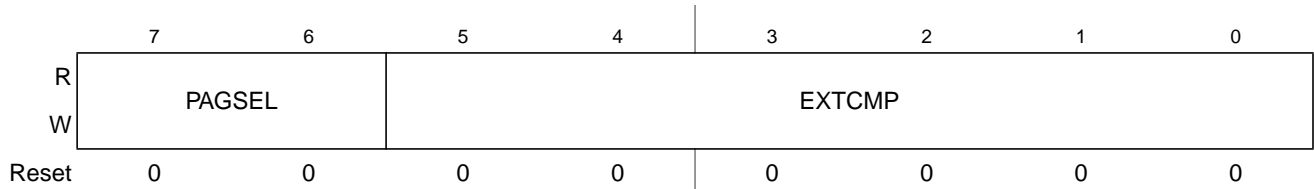

Figure 16-19. Debug Comparator B Extended Register (DBGCBX)

Table 16-22. DBGCBX Field Descriptions

Field	Description
7:6 PAGSEL	<p>Page Selector Field — If DBGEN is set in DBGVC1, then PAGSEL selects the type of paging as shown in Table 16-11.</p> <p>DPAGE and EPAGE are not yet implemented so the value in bit 7 will be ignored (i.e., PAGSEL values of 10 and 11 will be interpreted as values of 00 and 01, respectively.)</p> <p>In BKP mode, PAGSEL has no meaning and EXTCMP[5:0] are compared to address bits [19:14] if the address is in the FLASH/ROM memory space.</p>
5:0 EXTCMP	<p>Comparator B Extended Compare Bits — The EXTCMP bits are used as comparison address bits as shown in Table 16-11 along with the appropriate PPAGE, DPAGE, or EPAGE signal from the core. Also see Table 16-20.</p>

16.3.2.12 Debug Comparator B Register (DBGCB)

Module Base + 0x002E

Starting address location affected by INITRG register setting.

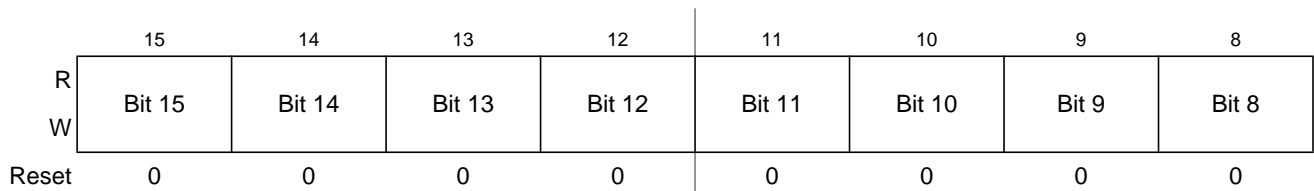

Figure 16-20. Debug Comparator B Register High (DBGCBH)

Module Base + 0x002F

Starting address location affected by INITRG register setting.

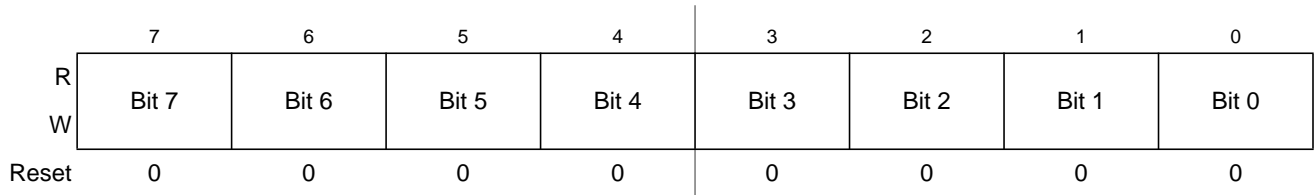

Figure 16-21. Debug Comparator B Register Low (DBGCB)

Table 16-23. DBGCB Field Descriptions

Field	Description
15:0	Comparator B Compare Bits — The comparator B compare bits control whether comparator B compares the address bus bits [15:0] or data bus bits [15:0] to a logic 1 or logic 0. See Table 16-20 .
15:0	
0	
1	Compare corresponding address bit to a logic 0, compares to data if in Full mode
1	Compare corresponding address bit to a logic 1, compares to data if in Full mode

16.4 Functional Description

This section provides a complete functional description of the DBG module. The DBG module can be configured to run in either of two modes, BKP or DBG. BKP mode is enabled by setting BKABEN in DBG2. DBG mode is enabled by setting DBGEN in DBG1. Setting BKABEN in DBG2 overrides the DBGEN in DBG1 and prevents DBG mode. If the part is in secure mode, DBG mode cannot be enabled.

16.4.1 DBG Operating in BKP Mode

In BKP mode, the DBG will be fully backwards compatible with the existing BKP_ST12_A module. The DBG2 register has four additional bits that were not available on existing BKP_ST12_A modules. As long as these bits are written to either all 1s or all 0s, they should be transparent to the user. All 1s would enable comparator C to be used as a breakpoint, but tagging would be enabled. The match address register would be all 0s if not modified by the user. Therefore, code executing at address 0x0000 would have to occur before a breakpoint based on comparator C would happen.

The DBG module in BKP mode supports two modes of operation: dual address mode and full breakpoint mode. Within each of these modes, forced or tagged breakpoint types can be used. Forced breakpoints occur at the next instruction boundary if a match occurs and tagged breakpoints allow for breaking just before the tagged instruction executes. The action taken upon a successful match can be to either place the CPU in background debug mode or to initiate a software interrupt.

The breakpoint can operate in dual address mode or full breakpoint mode. Each of these modes is discussed in the subsections below.

16.4.1.1 Dual Address Mode

When dual address mode is enabled, two address breakpoints can be set. Each breakpoint can cause the system to enter background debug mode or to initiate a software interrupt based upon the state of BDM in

DBGC2 being logic 1 or logic 0, respectively. BDM requests have a higher priority than SWI requests. No data breakpoints are allowed in this mode.

TAGAB in DBGC2 selects whether the breakpoint mode is forced or tagged. The BKxMBH:L bits in DBGC3 select whether or not the breakpoint is matched exactly or is a range breakpoint. They also select whether the address is matched on the high byte, low byte, both bytes, and/or memory expansion. The RWx and RWxEN bits in DBGC3 select whether the type of bus cycle to match is a read, write, or read/write when performing forced breakpoints.

16.4.1.2 Full Breakpoint Mode

Full breakpoint mode requires a match on address and data for a breakpoint to occur. Upon a successful match, the system will enter background debug mode or initiate a software interrupt based upon the state of BDM in DBGC2 being logic 1 or logic 0, respectively. BDM requests have a higher priority than SWI requests. R/W matches are also allowed in this mode.

TAGAB in DBGC2 selects whether the breakpoint mode is forced or tagged. When TAGAB is set in DBGC2, only addresses are compared and data is ignored. The BKAMBH:L bits in DBGC3 select whether or not the breakpoint is matched exactly, is a range breakpoint, or is in page space. The BKBMBH:L bits in DBGC3 select whether the data is matched on the high byte, low byte, or both bytes. RWA and RWAEN bits in DBGC2 select whether the type of bus cycle to match is a read or a write when performing forced breakpoints. RWB and RWBEN bits in DBGC2 are not used in full breakpoint mode.

NOTE

The full trigger mode is designed to be used for either a word access or a byte access, but not both at the same time. Confusing trigger operation (seemingly false triggers or no trigger) can occur if the trigger address occurs in the user program as both byte and word accesses.

16.4.1.3 Breakpoint Priority

Breakpoint operation is first determined by the state of the BDM module. If the BDM module is already active, meaning the CPU is executing out of BDM firmware, breakpoints are not allowed. In addition, while executing a BDM TRACE command, tagging into BDM is not allowed. If BDM is not active, the breakpoint will give priority to BDM requests over SWI requests. This condition applies to both forced and tagged breakpoints.

In all cases, BDM related breakpoints will have priority over those generated by the Breakpoint sub-block. This priority includes breakpoints enabled by the $\overline{\text{TAGLO}}$ and $\overline{\text{TAGHI}}$ external pins of the system that interface with the BDM directly and whose signal information passes through and is used by the breakpoint sub-block.

NOTE

BDM should not be entered from a breakpoint unless the ENABLE bit is set in the BDM. Even if the ENABLE bit in the BDM is cleared, the CPU actually executes the BDM firmware code. It checks the ENABLE and returns if ENABLE is not set. If the BDM is not serviced by the monitor then the breakpoint would be re-asserted when the BDM returns to normal CPU flow.

There is no hardware to enforce restriction of breakpoint operation if the BDM is not enabled.

When program control returns from a tagged breakpoint through an RTI or a BDM GO command, it will return to the instruction whose tag generated the breakpoint. Unless breakpoints are disabled or modified in the service routine or active BDM session, the instruction will be tagged again and the breakpoint will be repeated. In the case of BDM breakpoints, this situation can also be avoided by executing a TRACE1 command before the GO to increment the program flow past the tagged instruction.

16.4.1.4 Using Comparator C in BKP Mode

The original BKP_ST12_A module supports two breakpoints. The DBG_ST12_A module can be used in BKP mode and allow a third breakpoint using comparator C. Four additional bits, BKCEN, TAGC, RWCEN, and RWC in DBG_C2 in conjunction with additional comparator C address registers, DBG_C_CX, DBG_C_CH, and DBG_C_CL allow the user to set up a third breakpoint. Using PAGSEL in DBG_C_CX for expanded memory will work differently than the way paged memory is done using comparator A and B in BKP mode. See [Section 16.3.2.5, “Debug Comparator C Extended Register \(DBG_C_CX\)”](#) for more information on using comparator C.

16.4.2 DBG Operating in DBG Mode

Enabling the DBG module in DBG mode, allows the arming, triggering, and storing of data in the trace buffer and can be used to cause CPU breakpoints. The DBG module is made up of three main blocks, the comparators, trace buffer control logic, and the trace buffer.

NOTE

In general, there is a latency between the triggering event appearing on the bus and being detected by the DBG circuitry. In general, tagged triggers will be more predictable than forced triggers.

16.4.2.1 Comparators

The DBG contains three comparators, A, B, and C. Comparator A compares the core address bus with the address stored in DBG_C_AH and DBG_C_AL. Comparator B compares the core address bus with the address stored in DBG_C_BH and DBG_C_BL except in full mode, where it compares the data buses to the data stored in DBG_C_BH and DBG_C_BL. Comparator C can be used as a breakpoint generator or as the address comparison unit in the loop1 mode. Matches on comparator A, B, and C are signaled to the trace buffer

control (TBC) block. When PAGSEL = 01, registers DBGCAx, DBGCBx, and DBGCCx are used to match the upper addresses as shown in [Table 16-11](#).

NOTE

If a tagged-type C breakpoint is set at the same address as an A/B tagged-type trigger (including the initial entry in an inside or outside range trigger), the C breakpoint will have priority and the trigger will not be recognized.

16.4.2.1.1 Read or Write Comparison

Read or write comparisons are useful only with TRGSEL = 0, because only opcodes should be tagged as they are “read” from memory. RWAEN and RWBEN are ignored when TRGSEL = 1.

In full modes (“A and B” and “A and not B”) RWAEN and RWA are used to select read or write comparisons for both comparators A and B. [Table 16-24](#) shows the effect for RWAEN, RWA, and RW on the DBGCB comparison conditions. The RWBEN and RWB bits are not used and are ignored in full modes.

Table 16-24. Read or Write Comparison Logic Table

RWAEN bit	RWA bit	RW signal	Comment
0	x	0	Write data bus
0	x	1	Read data bus
1	0	0	Write data bus
1	0	1	No data bus compare since RW=1
1	1	0	No data bus compare since RW=0
1	1	1	Read data bus

16.4.2.1.2 Trigger Selection

The TRGSEL bit in DBGc1 is used to determine the triggering condition in DBG mode. TRGSEL applies to both trigger A and B except in the event only trigger modes. By setting TRGSEL, the comparators A and B will qualify a match with the output of opcode tracking logic and a trigger occurs before the tagged instruction executes (tagged-type trigger). With the TRGSEL bit cleared, a comparator match forces a trigger when the matching condition occurs (force-type trigger).

NOTE

If the TRGSEL is set, the address stored in the comparator match address registers must be an opcode address for the trigger to occur.

16.4.2.2 Trace Buffer Control (TBC)

The TBC is the main controller for the DBG module. Its function is to decide whether data should be stored in the trace buffer based on the trigger mode and the match signals from the comparator. The TBC also determines whether a request to break the CPU should occur.

16.4.2.3 Begin- and End-Trigger

The definitions of begin- and end-trigger as used in the DBG module are as follows:

- Begin-trigger: Storage in trace buffer occurs after the trigger and continues until 64 locations are filled.
- End-trigger: Storage in trace buffer occurs until the trigger, with the least recent data falling out of the trace buffer if more than 64 words are collected.

16.4.2.4 Arming the DBG Module

In DBG mode, arming occurs by setting DBGEN and ARM in DBGC1. The ARM bit in DBGC1 is cleared when the trigger condition is met in end-trigger mode or when the Trace Buffer is filled in begin-trigger mode. The TBC logic determines whether a trigger condition has been met based on the trigger mode and the trigger selection.

16.4.2.5 Trigger Modes

The DBG module supports nine trigger modes. The trigger modes are encoded as shown in [Table 16-6](#). The trigger mode is used as a qualifier for either starting or ending the storing of data in the trace buffer. When the match condition is met, the appropriate flag A or B is set in DBGSC. Arming the DBG module clears the A, B, and C flags in DBGSC. In all trigger modes except for the event-only modes and DETAIL capture mode, change-of-flow addresses are stored in the trace buffer. In the event-only modes only the value on the data bus at the trigger event B will be stored. In DETAIL capture mode address and data for all cycles except program fetch (P) and free (f) cycles are stored in trace buffer.

16.4.2.5.1 A Only

In the A only trigger mode, if the match condition for A is met, the A flag in DBGSC is set and a trigger occurs.

16.4.2.5.2 A or B

In the A or B trigger mode, if the match condition for A or B is met, the corresponding flag in DBGSC is set and a trigger occurs.

16.4.2.5.3 A then B

In the A then B trigger mode, the match condition for A must be met before the match condition for B is compared. When the match condition for A or B is met, the corresponding flag in DBGSC is set. The trigger occurs only after A then B have matched.

NOTE

When tagging and using A then B, if addresses A and B are close together, then B may not complete the trigger sequence. This occurs when A and B are in the instruction queue at the same time. Basically the A trigger has not yet occurred, so the B instruction is not tagged. Generally, if address B is at

least six addresses higher than address A (or B is lower than A) and there are not changes of flow to put these in the queue at the same time, then this operation should trigger properly.

16.4.2.5.4 Event-Only B (Store Data)

In the event-only B trigger mode, if the match condition for B is met, the B flag in DBGSC is set and a trigger occurs. The event-only B trigger mode is considered a begin-trigger type and the BEGIN bit in DBGSC1 is ignored. Event-only B is incompatible with instruction tagging (TRGSEL = 1), and thus the value of TRGSEL is ignored. Please refer to [Section 16.4.2.7, “Storage Memory,”](#) for more information.

This trigger mode is incompatible with the detail capture mode so the detail capture mode will have priority. TRGSEL and BEGIN will not be ignored and this trigger mode will behave as if it were “B only”.

16.4.2.5.5 A then Event-Only B (Store Data)

In the A then event-only B trigger mode, the match condition for A must be met before the match condition for B is compared, after the A match has occurred, a trigger occurs each time B matches. When the match condition for A or B is met, the corresponding flag in DBGSC is set. The A then event-only B trigger mode is considered a begin-trigger type and BEGIN in DBGSC1 is ignored. TRGSEL in DBGSC1 applies only to the match condition for A. Please refer to [Section 16.4.2.7, “Storage Memory,”](#) for more information.

This trigger mode is incompatible with the detail capture mode so the detail capture mode will have priority. TRGSEL and BEGIN will not be ignored and this trigger mode will be the same as A then B.

16.4.2.5.6 A and B (Full Mode)

In the A and B trigger mode, comparator A compares to the address bus and comparator B compares to the data bus. In the A and B trigger mode, if the match condition for A and B happen on the same bus cycle, both the A and B flags in the DBGSC register are set and a trigger occurs.

If TRGSEL = 1, only matches from comparator A are used to determine if the trigger condition is met and comparator B matches are ignored. If TRGSEL = 0, full-word data matches on an odd address boundary (misaligned access) do not work unless the access is to a RAM that manages misaligned accesses in a single clock cycle (which is typical of RAM modules used in HCS12 MCUs).

16.4.2.5.7 A and Not B (Full Mode)

In the A and not B trigger mode, comparator A compares to the address bus and comparator B compares to the data bus. In the A and not B trigger mode, if the match condition for A and not B happen on the same bus cycle, both the A and B flags in DBGSC are set and a trigger occurs.

If TRGSEL = 1, only matches from comparator A are used to determine if the trigger condition is met and comparator B matches are ignored. As described in [Section 16.4.2.5.6, “A and B \(Full Mode\),”](#) full-word data compares on misaligned accesses will not match expected data (and thus will cause a trigger in this mode) unless the access is to a RAM that manages misaligned accesses in a single clock cycle.

16.4.2.5.8 Inside Range ($A \leq \text{address} \leq B$)

In the inside range trigger mode, if the match condition for A and B happen on the same bus cycle, both the A and B flags in DBGSC are set and a trigger occurs. If a match condition on only A or only B occurs no flags are set. If TRGSEL = 1, the inside range is accurate only to word boundaries. If TRGSEL = 0, an aligned word access which straddles the range boundary will cause a trigger only if the aligned address is within the range.

16.4.2.5.9 Outside Range ($\text{address} < A$ or $\text{address} > B$)

In the outside range trigger mode, if the match condition for A or B is met, the corresponding flag in DBGSC is set and a trigger occurs. If TRGSEL = 1, the outside range is accurate only to word boundaries. If TRGSEL = 0, an aligned word access which straddles the range boundary will cause a trigger only if the aligned address is outside the range.

16.4.2.5.10 Control Bit Priorities

The definitions of some of the control bits are incompatible with each other. [Table 16-25](#) and the notes associated with it summarize how these incompatibilities are managed:

- Read/write comparisons are not compatible with TRGSEL = 1. Therefore, RWAEN and RWBEN are ignored.
- Event-only trigger modes are always considered a begin-type trigger. See [Section 16.4.2.8.1, “Storing with Begin-Trigger,”](#) and [Section 16.4.2.8.2, “Storing with End-Trigger.”](#)
- Detail capture mode has priority over the event-only trigger/capture modes. Therefore, event-only modes have no meaning in detail mode and their functions default to similar trigger modes.

Table 16-25. Resolution of Mode Conflicts

Mode	Normal / Loop1		Detail	
	Tag	Force	Tag	Force
A only				
A or B				
A then B				
Event-only B	1		1, 3	3
A then event-only B	2		4	4
A and B (full mode)	5		5	
A and not B (full mode)	5		5	
Inside range	6		6	
Outside range	6		6	

- 1 — Ignored — same as force
 2 — Ignored for comparator B
 3 — Reduces to effectively “B only”
 4 — Works same as A then B
 5 — Reduces to effectively “A only” — B not compared
 6 — Only accurate to word boundaries

16.4.2.6 Capture Modes

The DBG in DBG mode can operate in four capture modes. These modes are described in the following subsections.

16.4.2.6.1 Normal Mode

In normal mode, the DBG module uses comparator A and B as triggering devices. Change-of-flow information or data will be stored depending on TRG in DBGSC.

16.4.2.6.2 Loop1 Mode

The intent of loop1 mode is to prevent the trace buffer from being filled entirely with duplicate information from a looping construct such as delays using the DBNE instruction or polling loops using BRSET/BRCLR instructions. Immediately after address information is placed in the trace buffer, the DBG module writes this value into the C comparator and the C comparator is placed in ignore address mode. This will prevent duplicate address entries in the trace buffer resulting from repeated bit-conditional branches. Comparator C will be cleared when the ARM bit is set in loop1 mode to prevent the previous contents of the register from interfering with loop1 mode operation. Breakpoints based on comparator C are disabled.

Loop1 mode only inhibits duplicate source address entries that would typically be stored in most tight looping constructs. It will not inhibit repeated entries of destination addresses or vector addresses, because repeated entries of these would most likely indicate a bug in the user's code that the DBG module is designed to help find.

NOTE

In certain very tight loops, the source address will have already been fetched again before the C comparator is updated. This results in the source address being stored twice before further duplicate entries are suppressed. This condition occurs with branch-on-bit instructions when the branch is fetched by the first P-cycle of the branch or with loop-construct instructions in which the branch is fetched with the first or second P cycle. See examples below:

```

LOOP  INCX                ; 1-byte instruction fetched by 1st P-cycle of BRCLR
      BRCLR CMPMP,#$0c,LOOP ; the BRCLR instruction also will be fetched by 1st P-cycle of BRCLR

LOOP2 BRN   *             ; 2-byte instruction fetched by 1st P-cycle of DBNE
      NOP                ; 1-byte instruction fetched by 2nd P-cycle of DBNE
      DBNE  A,LOOP2       ; this instruction also fetched by 2nd P-cycle of DBNE
    
```

NOTE

Loop1 mode does not support paged memory, and inhibits duplicate entries in the trace buffer based solely on the CPU address. There is a remote possibility of an erroneous address match if program flow alternates between paged and unpaged memory space.

16.4.2.6.3 Detail Mode

In the detail mode, address and data for all cycles except program fetch (P) and free (f) cycles are stored in trace buffer. This mode is intended to supply additional information on indexed, indirect addressing modes where storing only the destination address would not provide all information required for a user to determine where his code was in error.

16.4.2.6.4 Profile Mode

This mode is intended to allow a host computer to poll a running target and provide a histogram of program execution. Each read of the trace buffer address will return the address of the last instruction executed. The DBG CNT register is not incremented and the trace buffer does not get filled. The ARM bit is not used and all breakpoints and all other debug functions will be disabled.

16.4.2.7 Storage Memory

The storage memory is a 64 words deep by 16-bits wide dual port RAM array. The CPU accesses the RAM array through a single memory location window (DBGTBH:DBGTBL). The DBG module stores trace information in the RAM array in a circular buffer format. As data is read via the CPU, a pointer into the RAM will increment so that the next CPU read will receive fresh information. In all trigger modes except for event-only and detail capture mode, the data stored in the trace buffer will be change-of-flow addresses. change-of-flow addresses are defined as follows:

- Source address of conditional branches (long, short, BRSET, and loop constructs) taken
- Destination address of indexed JMP, JSR, and CALL instruction
- Destination address of RTI, RTS, and RTC instructions
- Vector address of interrupts except for SWI and BDM vectors

In the event-only trigger modes only the 16-bit data bus value corresponding to the event is stored. In the detail capture mode, address and then data are stored for all cycles except program fetch (P) and free (f) cycles.

16.4.2.8 Storing Data in Memory Storage Buffer

16.4.2.8.1 Storing with Begin-Trigger

Storing with begin-trigger can be used in all trigger modes. When DBG mode is enabled and armed in the begin-trigger mode, data is not stored in the trace buffer until the trigger condition is met. As soon as the trigger condition is met, the DBG module will remain armed until 64 words are stored in the trace buffer. If the trigger is at the address of the change-of-flow instruction the change-of-flow associated with the trigger event will be stored in the trace buffer.

16.4.2.8.2 Storing with End-Trigger

Storing with end-trigger cannot be used in event-only trigger modes. When DBG mode is enabled and armed in the end-trigger mode, data is stored in the trace buffer until the trigger condition is met. When the trigger condition is met, the DBG module will become de-armed and no more data will be stored. If

the trigger is at the address of a change-of-flow address the trigger event will not be stored in the trace buffer.

16.4.2.9 Reading Data from Trace Buffer

The data stored in the trace buffer can be read using either the background debug module (BDM) module or the CPU provided the DBG module is enabled and not armed. The trace buffer data is read out first-in first-out. By reading CNT in DBGCNT the number of valid words can be determined. CNT will not decrement as data is read from DBGTBH:DBGTBL. The trace buffer data is read by reading DBGTBH:DBGTBL with a 16-bit read. Each time DBGTBH:DBGTBL is read, a pointer in the DBG will be incremented to allow reading of the next word.

Reading the trace buffer while the DBG module is armed will return invalid data and no shifting of the RAM pointer will occur.

NOTE

The trace buffer should be read with the DBG module enabled and in the same capture mode that the data was recorded. The contents of the trace buffer counter register (DBGCNT) are resolved differently in detail mode verses the other modes and may lead to incorrect interpretation of the trace buffer data.

16.4.3 Breakpoints

There are two ways of getting a breakpoint in DBG mode. One is based on the trigger condition of the trigger mode using comparator A and/or B, and the other is using comparator C. External breakpoints generated using the TAGHI and TAGLO external pins are disabled in DBG mode.

16.4.3.1 Breakpoint Based on Comparator A and B

A breakpoint request to the CPU can be enabled by setting DBGBRK in DBG C1. The value of BEGIN in DBG C1 determines when the breakpoint request to the CPU will occur. When BEGIN in DBG C1 is set, begin-trigger is selected and the breakpoint request will not occur until the trace buffer is filled with 64 words. When BEGIN in DBG C1 is cleared, end-trigger is selected and the breakpoint request will occur immediately at the trigger cycle.

There are two types of breakpoint requests supported by the DBG module, tagged and forced. Tagged breakpoints are associated with opcode addresses and allow breaking just before a specific instruction executes. Forced breakpoints are not associated with opcode addresses and allow breaking at the next instruction boundary. The type of breakpoint based on comparators A and B is determined by TRGSEL in the DBG C1 register (TRGSEL = 1 for tagged breakpoint, TRGSEL = 0 for forced breakpoint).

[Table 16-26](#) illustrates the type of breakpoint that will occur based on the debug run.

Table 16-26. Breakpoint Setup

BEGIN	TRGSEL	DBGBRK	Type of Debug Run
0	0	0	Fill trace buffer until trigger address (no CPU breakpoint — keep running)
0	0	1	Fill trace buffer until trigger address, then a forced breakpoint request occurs
0	1	0	Fill trace buffer until trigger opcode is about to execute (no CPU breakpoint — keep running)
0	1	1	Fill trace buffer until trigger opcode about to execute, then a tagged breakpoint request occurs
1	0	0	Start trace buffer at trigger address (no CPU breakpoint — keep running)
1	0	1	Start trace buffer at trigger address, a forced breakpoint request occurs when trace buffer is full
1	1	0	Start trace buffer at trigger opcode (no CPU breakpoint — keep running)
1	1	1	Start trace buffer at trigger opcode, a forced breakpoint request occurs when trace buffer is full

16.4.3.2 Breakpoint Based on Comparator C

A breakpoint request to the CPU can be created if BKCEN in DBGVC2 is set. Breakpoints based on a successful comparator C match can be accomplished regardless of the mode of operation for comparator A or B, and do not affect the status of the ARM bit. TAGC in DBGVC2 is used to select either tagged or forced breakpoint requests for comparator C. Breakpoints based on comparator C are disabled in LOOP1 mode.

NOTE

Because breakpoints cannot be disabled when the DBG is armed, one must be careful to avoid an “infinite breakpoint loop” when using tagged-type C breakpoints while the DBG is armed. If BDM breakpoints are selected, executing a TRACE1 instruction before the GO instruction is the recommended way to avoid re-triggering a breakpoint if one does not wish to de-arm the DBG. If SWI breakpoints are selected, disarming the DBG in the SWI interrupt service routine is the recommended way to avoid re-triggering a breakpoint.

16.5 Resets

The DBG module is disabled after reset.

The DBG module cannot cause a MCU reset.

16.6 Interrupts

The DBG contains one interrupt source. If a breakpoint is requested and BDM in DBGVC2 is cleared, an SWI interrupt will be generated.

Chapter 17

Interrupt (INTV1) Block Description

17.1 Introduction

This section describes the functionality of the interrupt (INT) sub-block of the S12 core platform.

A block diagram of the interrupt sub-block is shown in [Figure 17-1](#).

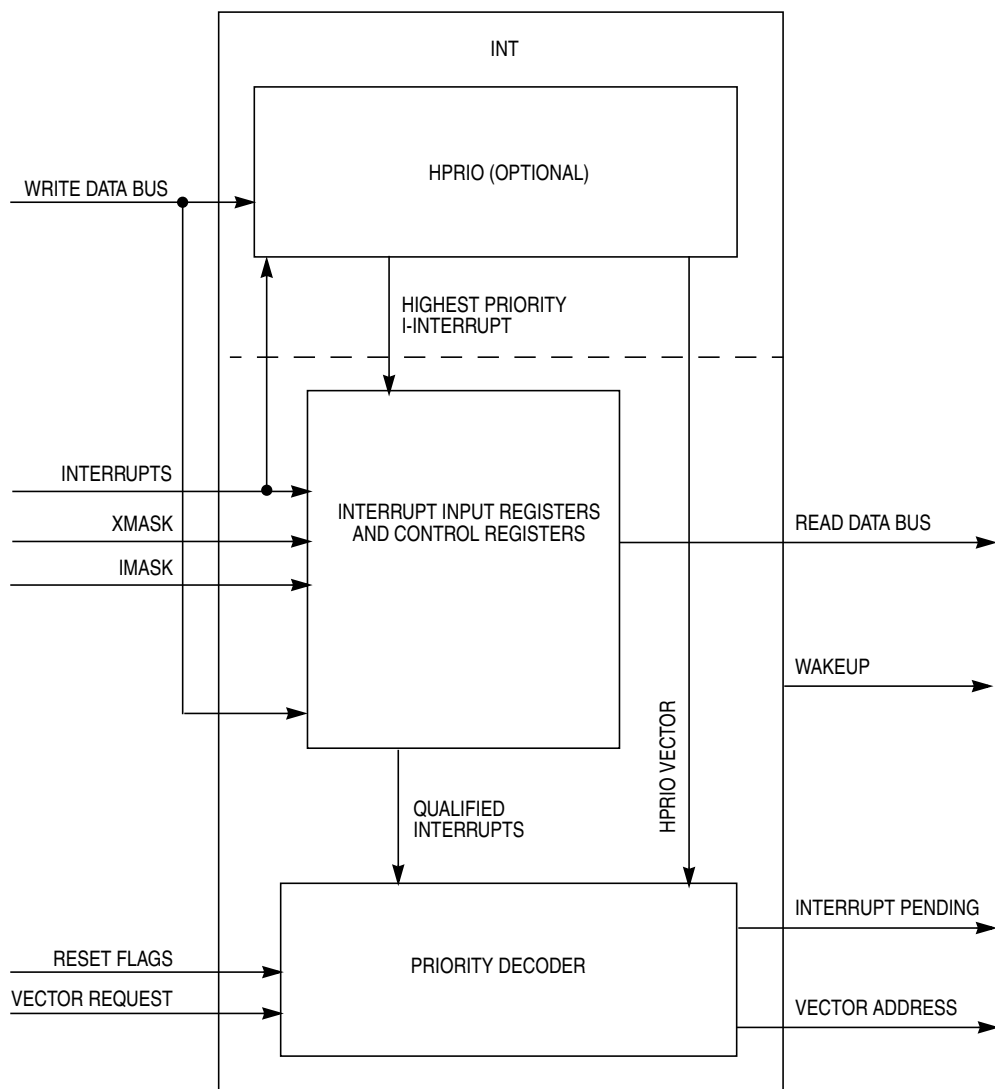

Figure 17-1. INTV1 Block Diagram

The interrupt sub-block decodes the priority of all system exception requests and provides the applicable vector for processing the exception. The INT supports I-bit maskable and X-bit maskable interrupts, a non-maskable unimplemented opcode trap, a non-maskable software interrupt (SWI) or background debug mode request, and three system reset vector requests. All interrupt related exception requests are managed by the interrupt sub-block (INT).

17.1.1 Features

The INT includes these features:

- Provides two to 122 I-bit maskable interrupt vectors (0xFF00–0xFFF2)
- Provides one X-bit maskable interrupt vector (0xFFF4)
- Provides a non-maskable software interrupt (SWI) or background debug mode request vector (0xFFF6)
- Provides a non-maskable unimplemented opcode trap (TRAP) vector (0xFFF8)
- Provides three system reset vectors (0xFFFA–0xFFFE) (reset, CMR, and COP)
- Determines the appropriate vector and drives it onto the address bus at the appropriate time
- Signals the CPU that interrupts are pending
- Provides control registers which allow testing of interrupts
- Provides additional input signals which prevents requests for servicing I and X interrupts
- Wakes the system from stop or wait mode when an appropriate interrupt occurs or whenever \overline{XIRQ} is active, even if \overline{XIRQ} is masked
- Provides asynchronous path for all I and X interrupts, (0xFF00–0xFFF4)
- (Optional) selects and stores the highest priority I interrupt based on the value written into the HPRIO register

17.1.2 Modes of Operation

The functionality of the INT sub-block in various modes of operation is discussed in the subsections that follow.

- **Normal operation**
The INT operates the same in all normal modes of operation.
- **Special operation**
Interrupts may be tested in special modes through the use of the interrupt test registers.
- **Emulation modes**
The INT operates the same in emulation modes as in normal modes.
- **Low power modes**
See [Section 17.4.1, “Low-Power Modes,”](#) for details

17.2 External Signal Description

Most interfacing with the interrupt sub-block is done within the core. However, the interrupt does receive direct input from the multiplexed external bus interface (MEBI) sub-block of the core for the $\overline{\text{IRQ}}$ and $\overline{\text{XIRQ}}$ pin data.

17.3 Memory Map and Register Definition

Detailed descriptions of the registers and associated bits are given in the subsections that follow.

17.3.1 Module Memory Map

Table 17-1. INT Memory Map

Address Offset	Use	Access
0x0015	Interrupt Test Control Register (ITCR)	R/W
0x0016	Interrupt Test Registers (ITEST)	R/W
0x001F	Highest Priority Interrupt (Optional) (HPRIO)	R/W

17.3.2 Register Descriptions

17.3.2.1 Interrupt Test Control Register

Module Base + 0x0015

Starting address location affected by INITRG register setting.

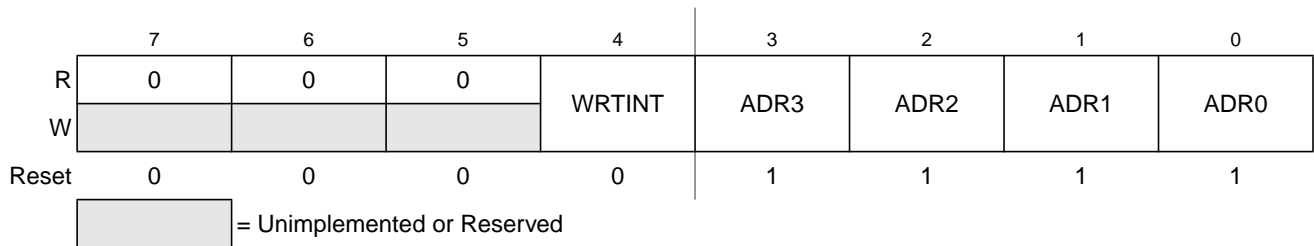

Figure 17-2. Interrupt Test Control Register (ITCR)

Read: See individual bit descriptions

Write: See individual bit descriptions

Table 17-2. ITCR Field Descriptions

Field	Description
4 WRTINT	<p>Write to the Interrupt Test Registers</p> <p>Read: anytime</p> <p>Write: only in special modes and with I-bit mask and X-bit mask set.</p> <p>0 Disables writes to the test registers; reads of the test registers will return the state of the interrupt inputs.</p> <p>1 Disconnect the interrupt inputs from the priority decoder and use the values written into the ITEST registers instead.</p> <p>Note: Any interrupts which are pending at the time that WRTINT is set will remain until they are overwritten.</p>
3:0 ADR[3:0]	<p>Test Register Select Bits</p> <p>Read: anytime</p> <p>Write: anytime</p> <p>These bits determine which test register is selected on a read or write. The hexadecimal value written here will be the same as the upper nibble of the lower byte of the vector selects. That is, an "F" written into ADR[3:0] will select vectors 0xFFFFE–0xFFFF0 while a "7" written to ADR[3:0] will select vectors 0xFF7E–0xFF70.</p>

17.3.2.2 Interrupt Test Registers

Module Base + 0x0016

Starting address location affected by INITRG register setting.

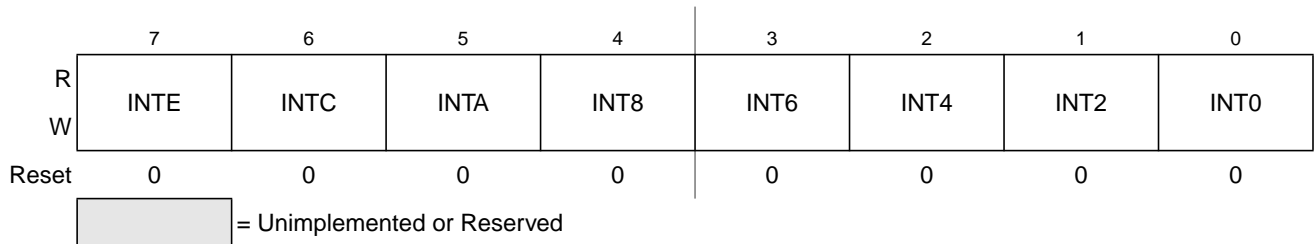

Figure 17-3. Interrupt TEST Registers (ITEST)

Read: Only in special modes. Reads will return either the state of the interrupt inputs of the interrupt sub-block (WRTINT = 0) or the values written into the TEST registers (WRTINT = 1). Reads will always return 0s in normal modes.

Write: Only in special modes and with WRTINT = 1 and CCR I mask = 1.

Table 17-3. ITEST Field Descriptions

Field	Description
7:0 INT[E:0]	<p>Interrupt TEST Bits — These registers are used in special modes for testing the interrupt logic and priority independent of the system configuration. Each bit is used to force a specific interrupt vector by writing it to a logic 1 state. Bits are named INTE through INTO to indicate vectors 0xFFxE through 0xFFx0. These bits can be written only in special modes and only with the WRTINT bit set (logic 1) in the interrupt test control register (ITCR). In addition, I interrupts must be masked using the I bit in the CCR. In this state, the interrupt input lines to the interrupt sub-block will be disconnected and interrupt requests will be generated only by this register. These bits can also be read in special modes to view that an interrupt requested by a system block (such as a peripheral block) has reached the INT module.</p> <p>There is a test register implemented for every eight interrupts in the overall system. All of the test registers share the same address and are individually selected using the value stored in the ADR[3:0] bits of the interrupt test control register (ITCR).</p> <p>Note: When ADR[3:0] have the value of 0x000F, only bits 2:0 in the ITEST register will be accessible. That is, vectors higher than 0xFFFF4 cannot be tested using the test registers and bits 7:3 will always read as a logic 0. If ADR[3:0] point to an unimplemented test register, writes will have no effect and reads will always return a logic 0 value.</p>

17.3.2.3 Highest Priority I Interrupt (Optional)

Module Base + 0x001F

Starting address location affected by INITRG register setting.

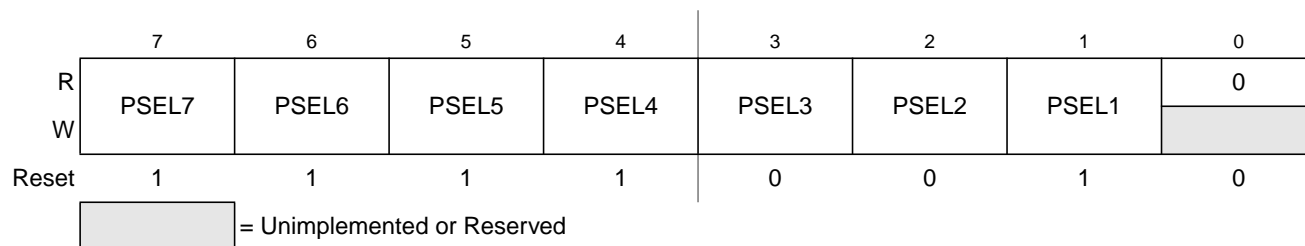

Figure 17-4. Highest Priority I Interrupt Register (HPRIO)

Read: Anytime

Write: Only if I mask in CCR = 1

Table 17-4. HPRIO Field Descriptions

Field	Description
7:1 PSEL[7:1]	<p>Highest Priority I Interrupt Select Bits — The state of these bits determines which I-bit maskable interrupt will be promoted to highest priority (of the I-bit maskable interrupts). To promote an interrupt, the user writes the least significant byte of the associated interrupt vector address to this register. If an unimplemented vector address or a non I-bit masked vector address (value higher than 0x00F2) is written, IRQ (0xFFF2) will be the default highest priority interrupt.</p>

17.4 Functional Description

The interrupt sub-block processes all exception requests made by the CPU. These exceptions include interrupt vector requests and reset vector requests. Each of these exception types and their overall priority level is discussed in the subsections below.

17.4.1 Low-Power Modes

The INT does not contain any user-controlled options for reducing power consumption. The operation of the INT in low-power modes is discussed in the following subsections.

17.4.1.1 Operation in Run Mode

The INT does not contain any options for reducing power in run mode.

17.4.1.2 Operation in Wait Mode

Clocks to the INT can be shut off during system wait mode and the asynchronous interrupt path will be used to generate the wake-up signal upon recognition of a valid interrupt or any $\overline{\text{XIRQ}}$ request.

17.4.1.3 Operation in Stop Mode

Clocks to the INT can be shut off during system stop mode and the asynchronous interrupt path will be used to generate the wake-up signal upon recognition of a valid interrupt or any $\overline{\text{XIRQ}}$ request.

17.5 Resets

The INT supports three system reset exception request types: normal system reset or power-on-reset request, crystal monitor reset request, and COP watchdog reset request. The type of reset exception request must be decoded by the system and the proper request made to the core. The INT will then provide the service routine address for the type of reset requested.

17.6 Interrupts

As shown in the block diagram in [Figure 17-1](#), the INT contains a register block to provide interrupt status and control, an optional highest priority I interrupt (HPRIO) block, and a priority decoder to evaluate whether pending interrupts are valid and assess their priority.

17.6.1 Interrupt Registers

The INT registers are accessible only in special modes of operation and function as described in [Section 17.3.2.1, “Interrupt Test Control Register,”](#) and [Section 17.3.2.2, “Interrupt Test Registers,”](#) previously.

17.6.2 Highest Priority I-Bit Maskable Interrupt

When the optional HPRIO block is implemented, the user is allowed to promote a single I-bit maskable interrupt to be the highest priority I interrupt. The HPRIO evaluates all interrupt exception requests and passes the HPRIO vector to the priority decoder if the highest priority I interrupt is active. RTI replaces the promoted interrupt source.

17.6.3 Interrupt Priority Decoder

The priority decoder evaluates all interrupts pending and determines their validity and priority. When the CPU requests an interrupt vector, the decoder will provide the vector for the highest priority interrupt request. Because the vector is not supplied until the CPU requests it, it is possible that a higher priority interrupt request could override the original exception that caused the CPU to request the vector. In this case, the CPU will receive the highest priority vector and the system will process this exception instead of the original request.

NOTE

Care must be taken to ensure that all exception requests remain active until the system begins execution of the applicable service routine; otherwise, the exception request may not be processed.

If for any reason the interrupt source is unknown (e.g., an interrupt request becomes inactive after the interrupt has been recognized but prior to the vector request), the vector address will default to that of the last valid interrupt that existed during the particular interrupt sequence. If the CPU requests an interrupt vector when there has never been a pending interrupt request, the INT will provide the software interrupt (SWI) vector address.

17.7 Exception Priority

The priority (from highest to lowest) and address of all exception vectors issued by the INT upon request by the CPU is shown in [Table 17-5](#).

Table 17-5. Exception Vector Map and Priority

Vector Address	Source
0xFFFFE–0xFFFFF	System reset
0xFFFFC–0xFFFFD	Crystal monitor reset
0xFFFFA–0xFFFFB	COP reset
0xFFFF8–0xFFFF9	Unimplemented opcode trap
0xFFFF6–0xFFFF7	Software interrupt instruction (SWI) or BDM vector request
0xFFFF4–0xFFFF5	$\overline{\text{XIRQ}}$ signal
0xFFFF2–0xFFFF3	$\overline{\text{IRQ}}$ signal
0xFFFF0–0xFF00	Device-specific I-bit maskable interrupt sources (priority in descending order)

Chapter 18

Multiplexed External Bus Interface (MEBIV3)

18.1 Introduction

This section describes the functionality of the multiplexed external bus interface (MEBI) sub-block of the S12 core platform. The functionality of the module is closely coupled with the S12 CPU and the memory map controller (MMC) sub-blocks.

Figure 18-1 is a block diagram of the MEBI. In Figure 18-1, the signals on the right hand side represent pins that are accessible externally. On some chips, these may not all be bonded out.

The MEBI sub-block of the core serves to provide access and/or visibility to internal core data manipulation operations including timing reference information at the external boundary of the core and/or system. Depending upon the system operating mode and the state of bits within the control registers of the MEBI, the internal 16-bit read and write data operations will be represented in 8-bit or 16-bit accesses externally. Using control information from other blocks within the system, the MEBI will determine the appropriate type of data access to be generated.

18.1.1 Features

The block name includes these distinctive features:

- External bus controller with four 8-bit ports A, B, E, and K
- Data and data direction registers for ports A, B, E, and K when used as general-purpose I/O
- Control register to enable/disable alternate functions on ports E and K
- Mode control register
- Control register to enable/disable pull resistors on ports A, B, E, and K
- Control register to enable/disable reduced output drive on ports A, B, E, and K
- Control register to configure external clock behavior
- Control register to configure $\overline{\text{IRQ}}$ pin operation
- Logic to capture and synchronize external interrupt pin inputs

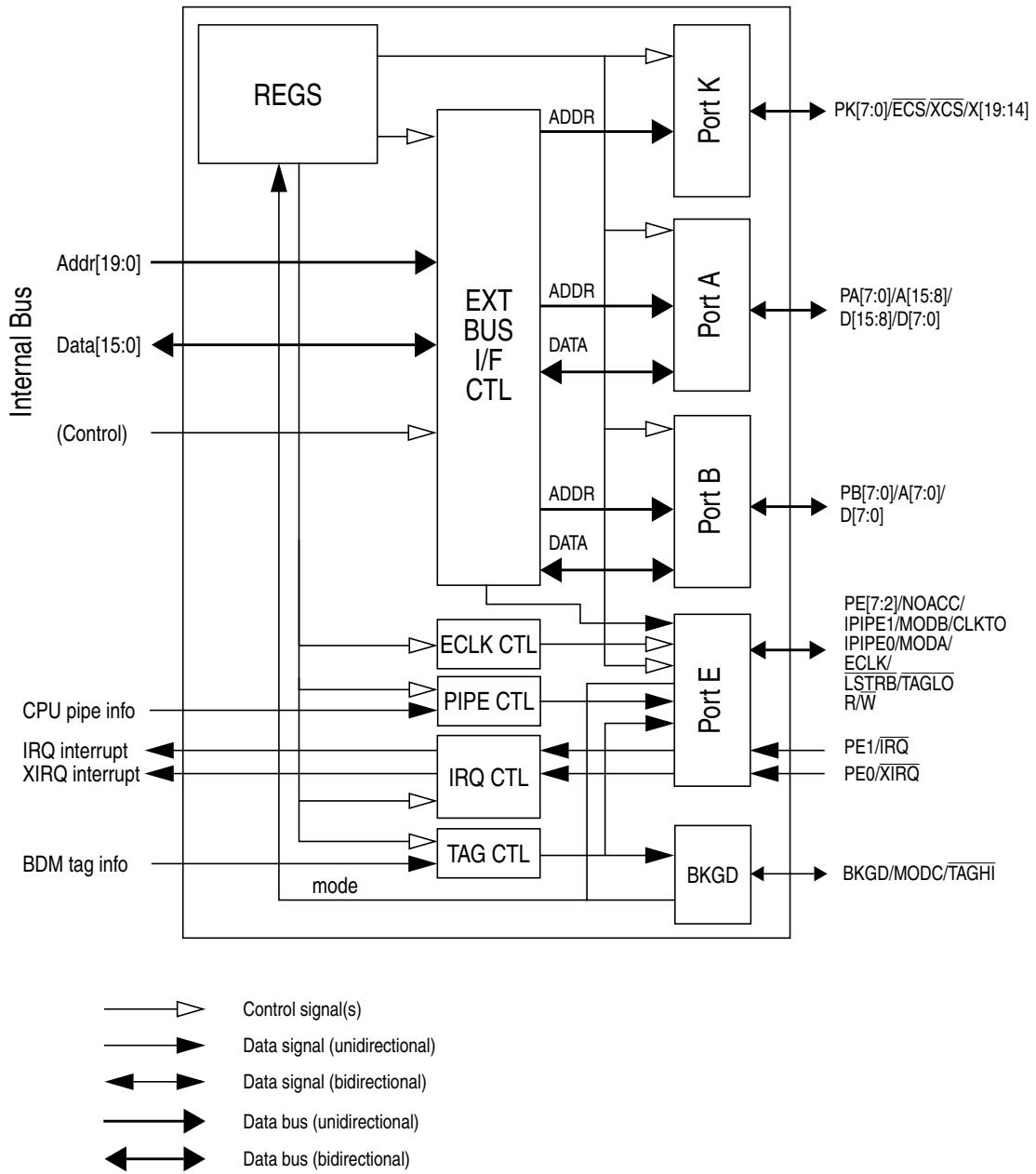

Figure 18-1. MEBI Block Diagram

18.1.2 Modes of Operation

- Normal expanded wide mode
Ports A and B are configured as a 16-bit multiplexed address and data bus and port E provides bus control and status signals. This mode allows 16-bit external memory and peripheral devices to be interfaced to the system.
- Normal expanded narrow mode
Ports A and B are configured as a 16-bit address bus and port A is multiplexed with 8-bit data. Port E provides bus control and status signals. This mode allows 8-bit external memory and peripheral devices to be interfaced to the system.
- Normal single-chip mode
There is no external expansion bus in this mode. The processor program is executed from internal memory. Ports A, B, K, and most of E are available as general-purpose I/O.
- Special single-chip mode
This mode is generally used for debugging single-chip operation, boot-strapping, or security related operations. The active background mode is in control of CPU execution and BDM firmware is waiting for additional serial commands through the BKGD pin. There is no external expansion bus after reset in this mode.
- Emulation expanded wide mode
Developers use this mode for emulation systems in which the users target application is normal expanded wide mode.
- Emulation expanded narrow mode
Developers use this mode for emulation systems in which the users target application is normal expanded narrow mode.
- Special test mode
Ports A and B are configured as a 16-bit multiplexed address and data bus and port E provides bus control and status signals. In special test mode, the write protection of many control bits is lifted so that they can be thoroughly tested without needing to go through reset.
- Special peripheral mode
This mode is intended for Freescale Semiconductor factory testing of the system. The CPU is inactive and an external (tester) bus master drives address, data, and bus control signals.

18.2 External Signal Description

In typical implementations, the MEBI sub-block of the core interfaces directly with external system pins. Some pins may not be bonded out in all implementations.

[Table 18-1](#) outlines the pin names and functions and gives a brief description of their operation reset state of these pins and associated pull-ups or pull-downs is dependent on the mode of operation and on the integration of this block at the chip level (chip dependent).

Table 18-1. External System Pins Associated With MEBI

Pin Name	Pin Functions	Description
BKGD/MODC/ TAGHI	MODC	At the rising edge on $\overline{\text{RESET}}$, the state of this pin is registered into the MODC bit to set the mode. (This pin always has an internal pullup.)
	BKGD	Pseudo open-drain communication pin for the single-wire background debug mode. There is an internal pull-up resistor on this pin.
	$\overline{\text{TAGHI}}$	When instruction tagging is on, a 0 at the falling edge of E tags the high half of the instruction word being read into the instruction queue.
PA7/A15/D15/D7 thru PA0/A8/D8/D0	PA7–PA0	General-purpose I/O pins, see PORTA and DDRA registers.
	A15–A8	High-order address lines multiplexed during ECLK low. Outputs except in special peripheral mode where they are inputs from an external tester system.
	D15–D8	High-order bidirectional data lines multiplexed during ECLK high in expanded wide modes, special peripheral mode, and visible internal accesses (IVIS = 1) in emulation expanded narrow mode. Direction of data transfer is generally indicated by R/\overline{W} .
	D15/D7 thru D8/D0	Alternate high-order and low-order bytes of the bidirectional data lines multiplexed during ECLK high in expanded narrow modes and narrow accesses in wide modes. Direction of data transfer is generally indicated by R/\overline{W} .
PB7/A7/D7 thru PB0/A0/D0	PB7–PB0	General-purpose I/O pins, see PORTB and DDRB registers.
	A7–A0	Low-order address lines multiplexed during ECLK low. Outputs except in special peripheral mode where they are inputs from an external tester system.
	D7–D0	Low-order bidirectional data lines multiplexed during ECLK high in expanded wide modes, special peripheral mode, and visible internal accesses (with IVIS = 1) in emulation expanded narrow mode. Direction of data transfer is generally indicated by R/\overline{W} .
PE7/NOACC	PE7	General-purpose I/O pin, see PORTE and DDRE registers.
	NOACC	CPU No Access output. Indicates whether the current cycle is a free cycle. Only available in expanded modes.
PE6/IPIPE1/ MODB/CLKTO	MODB	At the rising edge of $\overline{\text{RESET}}$, the state of this pin is registered into the MODB bit to set the mode.
	PE6	General-purpose I/O pin, see PORTE and DDRE registers.
	IPIPE1	Instruction pipe status bit 1, enabled by PIPOE bit in PEAR.
	CLKTO	System clock test output. Only available in special modes. PIPOE = 1 overrides this function. The enable for this function is in the clock module.
PE5/IPIPE0/MODA	MODA	At the rising edge on $\overline{\text{RESET}}$, the state of this pin is registered into the MODA bit to set the mode.
	PE5	General-purpose I/O pin, see PORTE and DDRE registers.
	IPIPE0	Instruction pipe status bit 0, enabled by PIPOE bit in PEAR.

Table 18-1. External System Pins Associated With MEBI (continued)

Pin Name	Pin Functions	Description
PE4/ECLK	PE4	General-purpose I/O pin, see PORTE and DDRE registers.
	ECLK	Bus timing reference clock, can operate as a free-running clock at the system clock rate or to produce one low-high clock per visible access, with the high period stretched for slow accesses. ECLK is controlled by the NECLK bit in PEAR, the IVIS bit in MODE, and the ESTR bit in EBICTL.
PE3/ $\overline{\text{LSTRB}}$ / $\overline{\text{TAGLO}}$	PE3	General-purpose I/O pin, see PORTE and DDRE registers.
	$\overline{\text{LSTRB}}$	Low strobe bar, 0 indicates valid data on D7–D0.
	SZ8	In special peripheral mode, this pin is an input indicating the size of the data transfer (0 = 16-bit; 1 = 8-bit).
	$\overline{\text{TAGLO}}$	In expanded wide mode or emulation narrow modes, when instruction tagging is on and low strobe is enabled, a 0 at the falling edge of E tags the low half of the instruction word being read into the instruction queue.
PE2/ $\overline{\text{R}}/\overline{\text{W}}$	PE2	General-purpose I/O pin, see PORTE and DDRE registers.
	$\overline{\text{R}}/\overline{\text{W}}$	Read/write, indicates the direction of internal data transfers. This is an output except in special peripheral mode where it is an input.
PE1/ $\overline{\text{IRQ}}$	PE1	General-purpose input-only pin, can be read even if $\overline{\text{IRQ}}$ enabled.
	$\overline{\text{IRQ}}$	Maskable interrupt request, can be level sensitive or edge sensitive.
PE0/ $\overline{\text{XIRQ}}$	PE0	General-purpose input-only pin.
	$\overline{\text{XIRQ}}$	Non-maskable interrupt input.
PK7/ $\overline{\text{ECS}}$	PK7	General-purpose I/O pin, see PORTK and DDRK registers.
	$\overline{\text{ECS}}$	Emulation chip select
PK6/ $\overline{\text{XCS}}$	PK6	General-purpose I/O pin, see PORTK and DDRK registers.
	$\overline{\text{XCS}}$	External data chip select
PK5/X19 thru PK0/X14	PK5–PK0	General-purpose I/O pins, see PORTK and DDRK registers.
	X19–X14	Memory expansion addresses

Detailed descriptions of these pins can be found in the device overview chapter.

18.3 Memory Map and Register Definition

A summary of the registers associated with the MEBI sub-block is shown in [Table 18-2](#). Detailed descriptions of the registers and bits are given in the subsections that follow. On most chips the registers are mappable. Therefore, the upper bits may not be all 0s as shown in the table and descriptions.

18.3.1 Module Memory Map

Table 18-2. MEBI Memory Map

Address Offset	Use	Access
0x0000	Port A Data Register (PORTA)	R/W
0x0001	Port B Data Register (PORTB)	R/W
0x0002	Data Direction Register A (DDRA)	R/W
0x0003	Data Direction Register B (DDRB)	R/W
0x0004	Reserved	R
0x0005	Reserved	R
0x0006	Reserved	R
0x0007	Reserved	R
0x0008	Port E Data Register (PORTE)	R/W
0x0009	Data Direction Register E (DDRE)	R/W
0x000A	Port E Assignment Register (PEAR)	R/W
0x000B	Mode Register (MODE)	R/W
0x000C	Pull Control Register (PUCR)	R/W
0x000D	Reduced Drive Register (RDRIV)	R/W
0x000E	External Bus Interface Control Register (EBICTL)	R/W
0x000F	Reserved	R
0x001E	IRQ Control Register (IRQCR)	R/W
0x00032	Port K Data Register (PORTK)	R/W
0x00033	Data Direction Register K (DDRK)	R/W

18.3.2 Register Descriptions

18.3.2.1 Port A Data Register (PORTA)

Module Base + 0x0000

Starting address location affected by INITRG register setting.

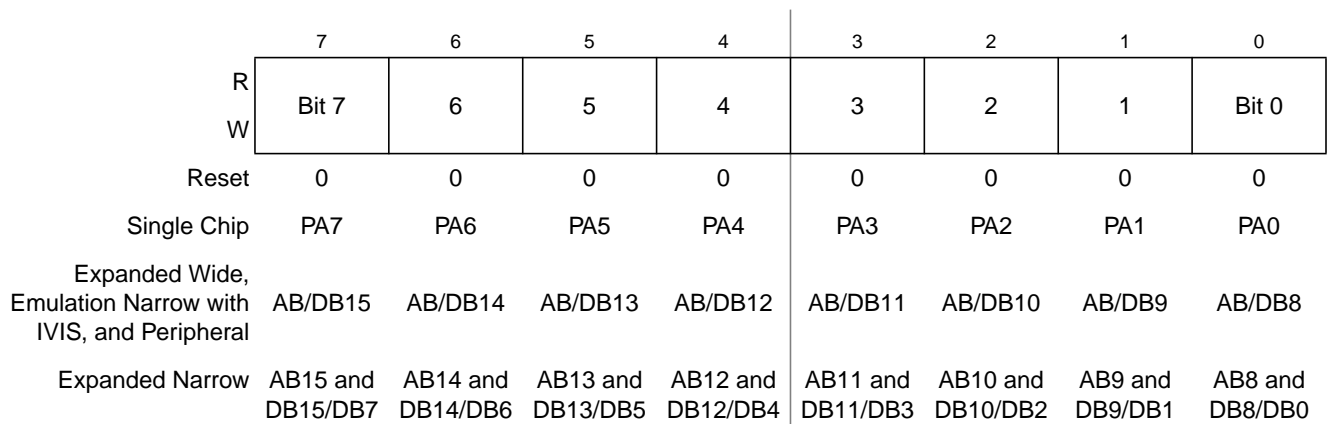

Figure 18-2. Port A Data Register (PORTA)

Read: Anytime when register is in the map

Write: Anytime when register is in the map

Port A bits 7 through 0 are associated with address lines A15 through A8 respectively and data lines D15/D7 through D8/D0 respectively. When this port is not used for external addresses such as in single-chip mode, these pins can be used as general-purpose I/O. Data direction register A (DDRA) determines the primary direction of each pin. DDRA also determines the source of data for a read of PORTA.

This register is not in the on-chip memory map in expanded and special peripheral modes. Therefore, these accesses will be echoed externally.

NOTE

To ensure that you read the value present on the PORTA pins, always wait at least one cycle after writing to the DDRA register before reading from the PORTA register.

18.3.2.2 Port B Data Register (PORTB)

Module Base + 0x0001

Starting address location affected by INITRG register setting.

	7	6	5	4	3	2	1	0
R	Bit 7	6	5	4	3	2	1	Bit 0
W								
Reset	0	0	0	0	0	0	0	0
Single Chip	PB7	PB6	PB5	PB4	PB3	PB2	PB1	PB0
Expanded Wide, Emulation Narrow with IVIS, and Peripheral	AB/DB7	AB/DB6	AB/DB5	AB/DB4	AB/DB3	AB/DB2	AB/DB1	AB/DB0
Expanded Narrow	AB7	AB6	AB5	AB4	AB3	AB2	AB1	AB0

Figure 18-3. Port A Data Register (PORTB)

Read: Anytime when register is in the map

Write: Anytime when register is in the map

Port B bits 7 through 0 are associated with address lines A7 through A0 respectively and data lines D7 through D0 respectively. When this port is not used for external addresses, such as in single-chip mode, these pins can be used as general-purpose I/O. Data direction register B (DDRB) determines the primary direction of each pin. DDRB also determines the source of data for a read of PORTB.

This register is not in the on-chip memory map in expanded and special peripheral modes. Therefore, these accesses will be echoed externally.

NOTE

To ensure that you read the value present on the PORTB pins, always wait at least one cycle after writing to the DDRB register before reading from the PORTB register.

18.3.2.3 Data Direction Register A (DDRA)

Module Base + 0x0002

Starting address location affected by INITRG register setting.

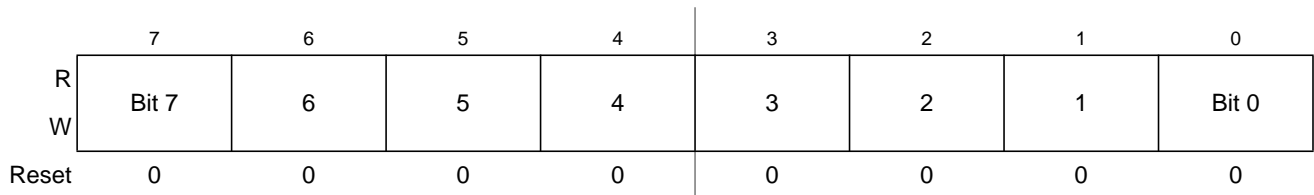

Figure 18-4. Data Direction Register A (DDRA)

Read: Anytime when register is in the map

Write: Anytime when register is in the map

This register controls the data direction for port A. When port A is operating as a general-purpose I/O port, DDRA determines the primary direction for each port A pin. A 1 causes the associated port pin to be an output and a 0 causes the associated pin to be a high-impedance input. The value in a DDR bit also affects the source of data for reads of the corresponding PORTA register. If the DDR bit is 0 (input) the buffered pin input state is read. If the DDR bit is 1 (output) the associated port data register bit state is read.

This register is not in the on-chip memory map in expanded and special peripheral modes. Therefore, these accesses will be echoed externally. It is reset to 0x00 so the DDR does not override the three-state control signals.

Table 18-3. DDRA Field Descriptions

Field	Description
7:0 DDRA	Data Direction Port A 0 Configure the corresponding I/O pin as an input 1 Configure the corresponding I/O pin as an output

18.3.2.4 Data Direction Register B (DDRB)

Module Base + 0x0003

Starting address location affected by INITRG register setting.

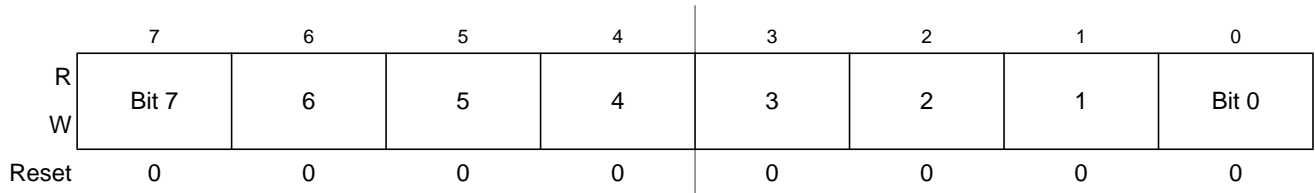

Figure 18-5. Data Direction Register B (DDRB)

Read: Anytime when register is in the map

Write: Anytime when register is in the map

This register controls the data direction for port B. When port B is operating as a general-purpose I/O port, DDRB determines the primary direction for each port B pin. A 1 causes the associated port pin to be an output and a 0 causes the associated pin to be a high-impedance input. The value in a DDR bit also affects the source of data for reads of the corresponding PORTB register. If the DDR bit is 0 (input) the buffered pin input state is read. If the DDR bit is 1 (output) the associated port data register bit state is read.

This register is not in the on-chip memory map in expanded and special peripheral modes. Therefore, these accesses will be echoed externally. It is reset to 0x00 so the DDR does not override the three-state control signals.

Table 18-4. DDRB Field Descriptions

Field	Description
7:0 DDRB	<p>Data Direction Port B</p> <p>0 Configure the corresponding I/O pin as an input</p> <p>1 Configure the corresponding I/O pin as an output</p>

18.3.2.5 Reserved Registers

Module Base + 0x0004

Starting address location affected by INITRG register setting.

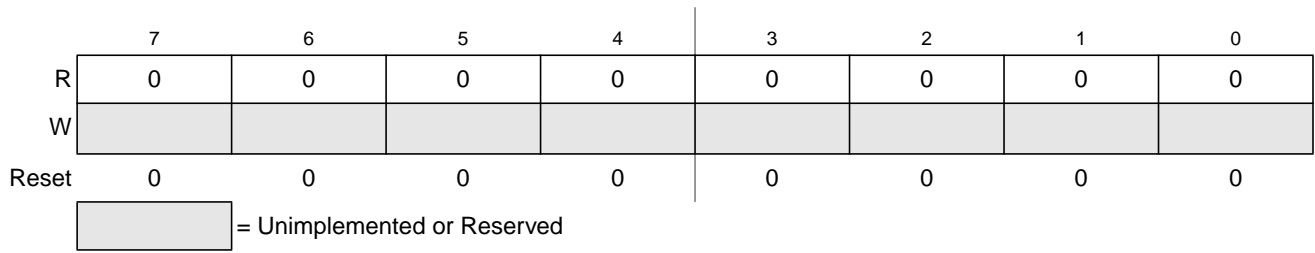

Figure 18-6. Reserved Register

Module Base + 0x0005

Starting address location affected by INITRG register setting.

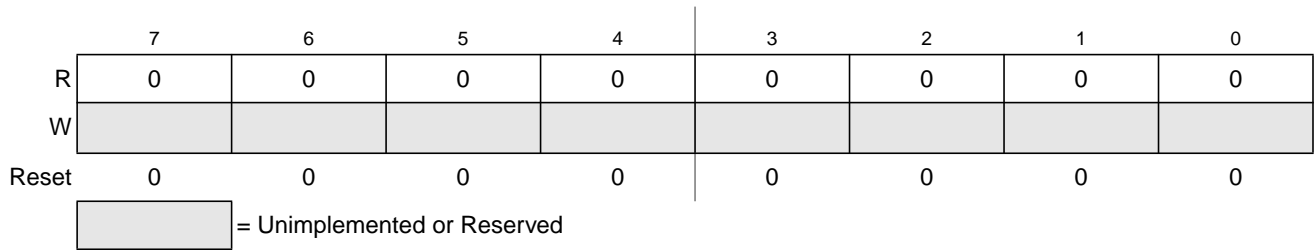

Figure 18-7. Reserved Register

Module Base + 0x0006

Starting address location affected by INITRG register setting.

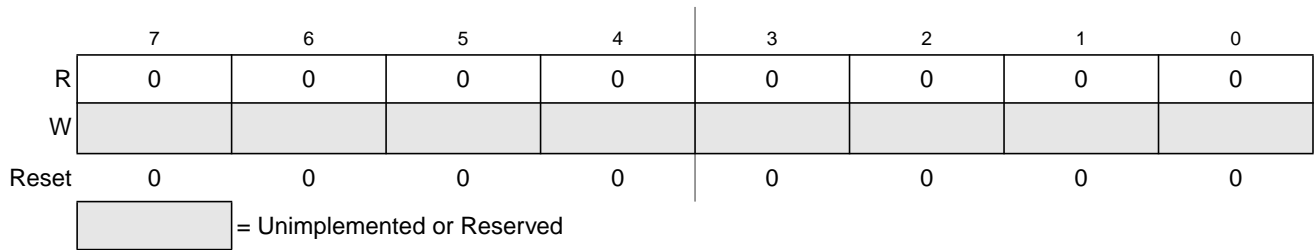

Figure 18-8. Reserved Register

Module Base + 0x0007

Starting address location affected by INITRG register setting.

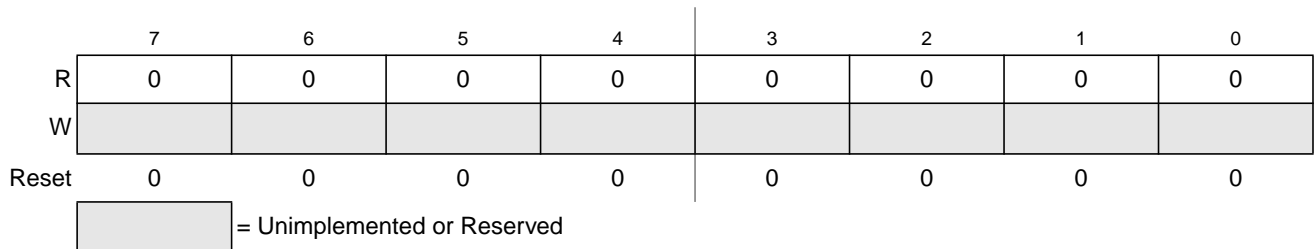

Figure 18-9. Reserved Register

These register locations are not used (reserved). All unused registers and bits in this block return logic 0s when read. Writes to these registers have no effect.

These registers are not in the on-chip map in special peripheral mode.

18.3.2.6 Port E Data Register (PORTE)

Module Base + 0x0008

Starting address location affected by INITRG register setting.

	7	6	5	4	3	2	1	0
R	Bit 7	6	5	4	3	2	Bit 1	Bit 0
W								
Reset	0	0	0	0	0	0	u	u
Alternate Pin Function	NOACC	MODB or IPIPE1 or CLKTO	MODA or IPIPE0	ECLK	$\overline{\text{LSTRB}}$ or $\overline{\text{TAGLO}}$	R/ $\overline{\text{W}}$	$\overline{\text{IRQ}}$	$\overline{\text{XIRQ}}$
	= Unimplemented or Reserved				u = Unaffected by reset			

Figure 18-10. Port E Data Register (PORTE)

Read: Anytime when register is in the map

Write: Anytime when register is in the map

Port E is associated with external bus control signals and interrupt inputs. These include mode select (MODB/IPIPE1, MODA/IPIPE0), E clock, size ($\overline{\text{LSTRB}}$ / $\overline{\text{TAGLO}}$), read/write (R/ $\overline{\text{W}}$), $\overline{\text{IRQ}}$, and $\overline{\text{XIRQ}}$. When not used for one of these specific functions, port E pins 7:2 can be used as general-purpose I/O and pins 1:0 can be used as general-purpose input. The port E assignment register (PEAR) selects the function of each pin and DDRE determines whether each pin is an input or output when it is configured to be general-purpose I/O. DDRE also determines the source of data for a read of PORTE.

Some of these pins have software selectable pull resistors. $\overline{\text{IRQ}}$ and $\overline{\text{XIRQ}}$ can only be pulled up whereas the polarity of the PE7, PE4, PE3, and PE2 pull resistors are determined by chip integration. Please refer to the device overview chapter (Signal Property Summary) to determine the polarity of these resistors. A single control bit enables the pull devices for all of these pins when they are configured as inputs.

This register is not in the on-chip map in special peripheral mode or in expanded modes when the EME bit is set. Therefore, these accesses will be echoed externally.

NOTE

It is unwise to write PORTE and DDRE as a word access. If you are changing port E pins from being inputs to outputs, the data may have extra transitions during the write. It is best to initialize PORTE before enabling as outputs.

NOTE

To ensure that you read the value present on the PORTE pins, always wait at least one cycle after writing to the DDRE register before reading from the PORTE register.

18.3.2.7 Data Direction Register E (DDRE)

Module Base + 0x0009

Starting address location affected by INITRG register setting.

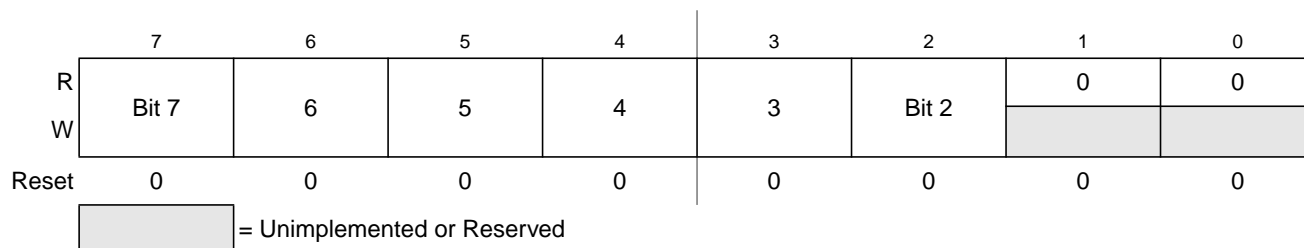

Figure 18-11. Data Direction Register E (DDRE)

Read: Anytime when register is in the map

Write: Anytime when register is in the map

Data direction register E is associated with port E. For bits in port E that are configured as general-purpose I/O lines, DDRE determines the primary direction of each of these pins. A 1 causes the associated bit to be an output and a 0 causes the associated bit to be an input. Port E bit 1 (associated with \overline{IRQ}) and bit 0 (associated with \overline{XIRQ}) cannot be configured as outputs. Port E, bits 1 and 0, can be read regardless of whether the alternate interrupt function is enabled. The value in a DDR bit also affects the source of data for reads of the corresponding PORTE register. If the DDR bit is 0 (input) the buffered pin input state is read. If the DDR bit is 1 (output) the associated port data register bit state is read.

This register is not in the on-chip memory map in expanded and special peripheral modes. Therefore, these accesses will be echoed externally. Also, it is not in the map in expanded modes while the EME control bit is set.

Table 18-5. DDRE Field Descriptions

Field	Description
7:2 DDRE	<p>Data Direction Port E</p> <p>0 Configure the corresponding I/O pin as an input</p> <p>1 Configure the corresponding I/O pin as an output</p> <p>Note: It is unwise to write PORTE and DDRE as a word access. If you are changing port E pins from inputs to outputs, the data may have extra transitions during the write. It is best to initialize PORTE before enabling as outputs.</p>

18.3.2.8 Port E Assignment Register (PEAR)

Module Base + 0x000A

Starting address location affected by INITRG register setting.

	7	6	5	4	3	2	1	0
R	NOACCE	0	PIPOE	NECLK	LSTRE	RDWE	0	0
W								
Reset								
Special Single Chip	0	0	0	0	0	0	0	0
Special Test	0	0	1	0	1	1	0	0
Peripheral	0	0	0	0	0	0	0	0
Emulation Expanded Narrow	1	0	1	0	1	1	0	0
Emulation Expanded Wide	1	0	1	0	1	1	0	0
Normal Single Chip	0	0	0	1	0	0	0	0
Normal Expanded Narrow	0	0	0	0	0	0	0	0
Normal Expanded Wide	0	0	0	0	0	0	0	0

= Unimplemented or Reserved

Figure 18-12. Port E Assignment Register (PEAR)

Read: Anytime (provided this register is in the map).

Write: Each bit has specific write conditions. Please refer to the descriptions of each bit on the following pages.

Port E serves as general-purpose I/O or as system and bus control signals. The PEAR register is used to choose between the general-purpose I/O function and the alternate control functions. When an alternate control function is selected, the associated DDRE bits are overridden.

The reset condition of this register depends on the mode of operation because bus control signals are needed immediately after reset in some modes. In normal single-chip mode, no external bus control signals are needed so all of port E is configured for general-purpose I/O. In normal expanded modes, only the E clock is configured for its alternate bus control function and the other bits of port E are configured for general-purpose I/O. As the reset vector is located in external memory, the E clock is required for this access. R/\overline{W} is only needed by the system when there are external writable resources. If the normal expanded system needs any other bus control signals, PEAR would need to be written before any access that needed the additional signals. In special test and emulation modes, IPIPE1, IPIPE0, E, \overline{LSTRB} , and R/\overline{W} are configured out of reset as bus control signals.

This register is not in the on-chip memory map in expanded and special peripheral modes. Therefore, these accesses will be echoed externally.

Table 18-6. PEAR Field Descriptions

Field	Description
7 NOACCE	CPU No Access Output Enable Normal: write once Emulation: write never Special: write anytime 1 The associated pin (port E, bit 7) is general-purpose I/O. 0 The associated pin (port E, bit 7) is output and indicates whether the cycle is a CPU free cycle. This bit has no effect in single-chip or special peripheral modes.
5 PIPOE	Pipe Status Signal Output Enable Normal: write once Emulation: write never Special: write anytime. 0 The associated pins (port E, bits 6:5) are general-purpose I/O. 1 The associated pins (port E, bits 6:5) are outputs and indicate the state of the instruction queue This bit has no effect in single-chip or special peripheral modes.
4 NECLK	No External E Clock Normal and special: write anytime Emulation: write never 0 The associated pin (port E, bit 4) is the external E clock pin. External E clock is free-running if ESTR = 0 1 The associated pin (port E, bit 4) is a general-purpose I/O pin. External E clock is available as an output in all modes.
3 LSTRE	Low Strobe (LSTRB) Enable Normal: write once Emulation: write never Special: write anytime. 0 The associated pin (port E, bit 3) is a general-purpose I/O pin. 1 The associated pin (port E, bit 3) is configured as the $\overline{\text{LSTRB}}$ bus control output. If BDM tagging is enabled, $\overline{\text{TAGLO}}$ is multiplexed in on the rising edge of ECLK and $\overline{\text{LSTRB}}$ is driven out on the falling edge of ECLK. This bit has no effect in single-chip, peripheral, or normal expanded narrow modes. Note: $\overline{\text{LSTRB}}$ is used during external writes. After reset in normal expanded mode, $\overline{\text{LSTRB}}$ is disabled to provide an extra I/O pin. If $\overline{\text{LSTRB}}$ is needed, it should be enabled before any external writes. External reads do not normally need $\overline{\text{LSTRB}}$ because all 16 data bits can be driven even if the system only needs 8 bits of data.
2 RDWE	Read/Write Enable Normal: write once Emulation: write never Special: write anytime 0 The associated pin (port E, bit 2) is a general-purpose I/O pin. 1 The associated pin (port E, bit 2) is configured as the $\overline{\text{R/W}}$ pin This bit has no effect in single-chip or special peripheral modes. Note: $\overline{\text{R/W}}$ is used for external writes. After reset in normal expanded mode, $\overline{\text{R/W}}$ is disabled to provide an extra I/O pin. If $\overline{\text{R/W}}$ is needed it should be enabled before any external writes.

18.3.2.9 Mode Register (MODE)

Module Base + 0x000B

Starting address location affected by INITRG register setting.

	7	6	5	4	3	2	1	0
R	MODC	MODB	MODA	0	IVIS	0	EMK	EME
W								
Reset								
Special Single Chip	0	0	0	0	0	0	0	0
Emulation Expanded Narrow	0	0	1	0	1	0	1	1
Special Test	0	1	0	0	1	0	0	0
Emulation Expanded Wide	0	1	1	0	1	0	1	1
Normal Single Chip	1	0	0	0	0	0	0	0
Normal Expanded Narrow	1	0	1	0	0	0	0	0
Peripheral	1	1	0	0	0	0	0	0
Normal Expanded Wide	1	1	1	0	0	0	0	0

= Unimplemented or Reserved

Figure 18-13. Mode Register (MODE)

Read: Anytime (provided this register is in the map).

Write: Each bit has specific write conditions. Please refer to the descriptions of each bit on the following pages.

The MODE register is used to establish the operating mode and other miscellaneous functions (i.e., internal visibility and emulation of port E and K).

In special peripheral mode, this register is not accessible but it is reset as shown to system configuration features. Changes to bits in the MODE register are delayed one cycle after the write.

This register is not in the on-chip memory map in expanded and special peripheral modes. Therefore, these accesses will be echoed externally.

Table 18-7. MODE Field Descriptions

Field	Description
7:5 MOD[C:A]	<p>Mode Select Bits — These bits indicate the current operating mode.</p> <p>If MODA = 1, then MODC, MODB, and MODA are write never.</p> <p>If MODC = MODA = 0, then MODC, MODB, and MODA are writable with the exception that you cannot change to or from special peripheral mode</p> <p>If MODC = 1, MODB = 0, and MODA = 0, then MODC is write never. MODB and MODA are write once, except that you cannot change to special peripheral mode. From normal single-chip, only normal expanded narrow and normal expanded wide modes are available.</p> <p>See Table 18-8 and Table 18-16.</p>
3 IVIS	<p>Internal Visibility (for both read and write accesses) — This bit determines whether internal accesses generate a bus cycle that is visible on the external bus.</p> <p>Normal: write once Emulation: write never Special: write anytime</p> <p>0 No visibility of internal bus operations on external bus. 1 Internal bus operations are visible on external bus.</p>
1 EMK	<p>Emulate Port K</p> <p>Normal: write once Emulation: write never Special: write anytime</p> <p>0 PORTK and DDRK are in the memory map so port K can be used for general-purpose I/O. 1 If in any expanded mode, PORTK and DDRK are removed from the memory map.</p> <p>In single-chip modes, PORTK and DDRK are always in the map regardless of the state of this bit. In special peripheral mode, PORTK and DDRK are never in the map regardless of the state of this bit.</p>
0 EME	<p>Emulate Port E</p> <p>Normal and Emulation: write never Special: write anytime</p> <p>0 PORTE and DDRE are in the memory map so port E can be used for general-purpose I/O. 1 If in any expanded mode or special peripheral mode, PORTE and DDRE are removed from the memory map. Removing the registers from the map allows the user to emulate the function of these registers externally. In single-chip modes, PORTE and DDRE are always in the map regardless of the state of this bit.</p>

Table 18-8. MODC, MODB, and MODA Write Capability^a

MODC	MODB	MODA	Mode	MODx Write Capability
0	0	0	Special single chip	MODC, MODB, and MODA write anytime but not to 110 ^b
0	0	1	Emulation narrow	No write
0	1	0	Special test	MODC, MODB, and MODA write anytime but not to 110 ⁽²⁾
0	1	1	Emulation wide	No write
1	0	0	Normal single chip	MODC write never, MODB and MODA write once but not to 110
1	0	1	Normal expanded narrow	No write
1	1	0	Special peripheral	No write
1	1	1	Normal expanded wide	No write

^a No writes to the MOD bits are allowed while operating in a secure mode. For more details, refer to the device overview chapter.

^b If you are in a special single-chip or special test mode and you write to this register, changing to normal single-chip mode, then one allowed write to this register remains. If you write to normal expanded or emulation mode, then no writes remain.

18.3.2.10 Pull Control Register (PUCR)

Module Base + 0x000C

Starting address location affected by INITRG register setting.

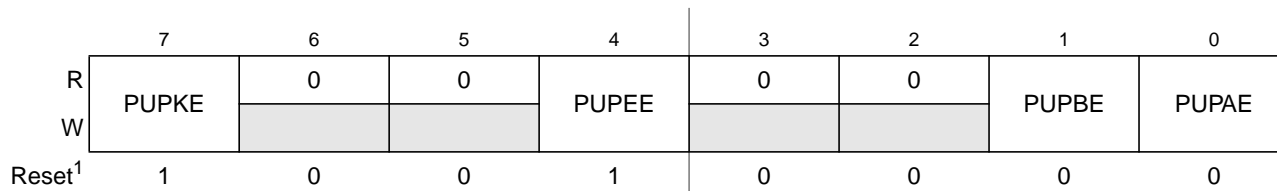

NOTES:

1. The default value of this parameter is shown. Please refer to the device overview chapter to determine the actual reset state of this register.

= Unimplemented or Reserved

Figure 18-14. Pull Control Register (PUCR)

Read: Anytime (provided this register is in the map).

Write: Anytime (provided this register is in the map).

This register is used to select pull resistors for the pins associated with the core ports. Pull resistors are assigned on a per-port basis and apply to any pin in the corresponding port that is currently configured as an input. The polarity of these pull resistors is determined by chip integration. Please refer to the device overview chapter to determine the polarity of these resistors.

This register is not in the on-chip memory map in expanded and special peripheral modes. Therefore, these accesses will be echoed externally.

NOTE

These bits have no effect when the associated pin(s) are outputs. (The pull resistors are inactive.)

Table 18-9. PUCR Field Descriptions

Field	Description
7 PUPKE	Pull resistors Port K Enable 0 Port K pull resistors are disabled. 1 Enable pull resistors for port K input pins.
4 PUPEE	Pull resistors Port E Enable 0 Port E pull resistors on bits 7, 4:0 are disabled. 1 Enable pull resistors for port E input pins bits 7, 4:0. Note: Pins 5 and 6 of port E have pull resistors which are only enabled during reset. This bit has no effect on these pins.
1 PUPBE	Pull resistors Port B Enable 0 Port B pull resistors are disabled. 1 Enable pull resistors for all port B input pins.
0 PUPAE	Pull resistors Port A Enable 0 Port A pull resistors are disabled. 1 Enable pull resistors for all port A input pins.

18.3.2.11 Reduced Drive Register (RDRIV)

Module Base + 0x000D

Starting address location affected by INITRG register setting.

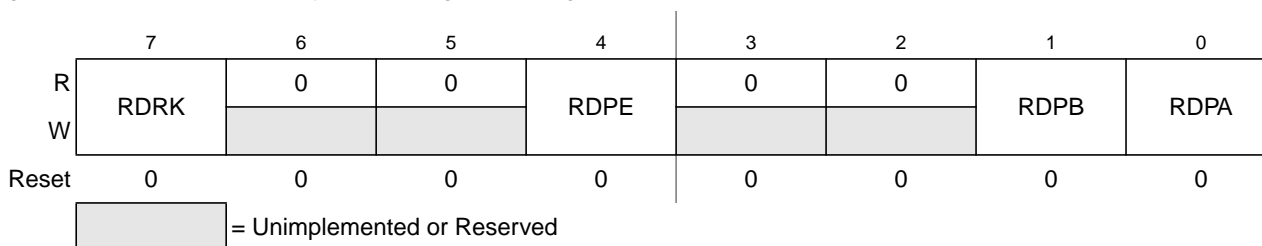

Figure 18-15. Reduced Drive Register (RDRIV)

Read: Anytime (provided this register is in the map)

Write: Anytime (provided this register is in the map)

This register is used to select reduced drive for the pins associated with the core ports. This gives reduced power consumption and reduced RFI with a slight increase in transition time (depending on loading). This feature would be used on ports which have a light loading. The reduced drive function is independent of which function is being used on a particular port.

This register is not in the on-chip memory map in expanded and special peripheral modes. Therefore, these accesses will be echoed externally.

Table 18-10. RDRIV Field Descriptions

Field	Description
7 RDRK	Reduced Drive of Port K 0 All port K output pins have full drive enabled. 1 All port K output pins have reduced drive enabled.
4 RDPE	Reduced Drive of Port E 0 All port E output pins have full drive enabled. 1 All port E output pins have reduced drive enabled.
1 RDPB	Reduced Drive of Port B 0 All port B output pins have full drive enabled. 1 All port B output pins have reduced drive enabled.
0 RDPA	Reduced Drive of Ports A 0 All port A output pins have full drive enabled. 1 All port A output pins have reduced drive enabled.

18.3.2.12 External Bus Interface Control Register (EBICTL)

Module Base + 0x000E

Starting address location affected by INITRG register setting.

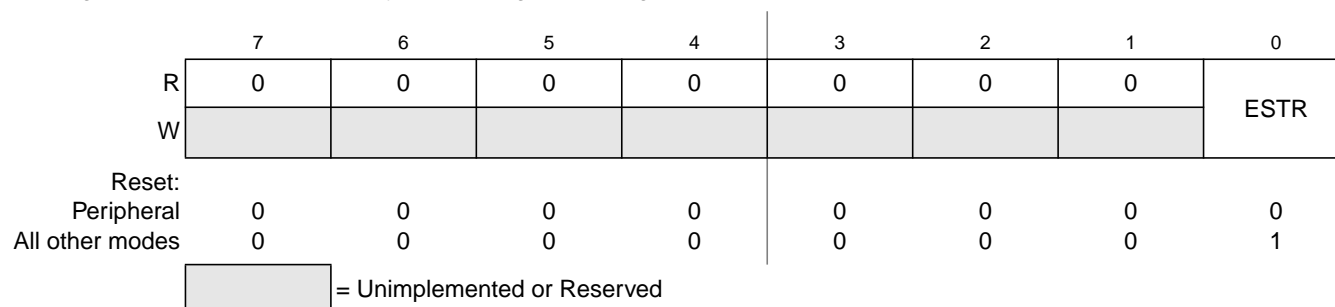

Figure 18-16. External Bus Interface Control Register (EBICTL)

Read: Anytime (provided this register is in the map)

Write: Refer to individual bit descriptions below

The EBICTL register is used to control miscellaneous functions (i.e., stretching of external E clock).

This register is not in the on-chip memory map in expanded and special peripheral modes. Therefore, these accesses will be echoed externally.

Table 18-11. EBICTL Field Descriptions

Field	Description
0 ESTR	E Clock Stretches — This control bit determines whether the E clock behaves as a simple free-running clock or as a bus control signal that is active only for external bus cycles. Normal and Emulation: write once Special: write anytime 0 E never stretches (always free running). 1 E stretches high during stretched external accesses and remains low during non-visible internal accesses. This bit has no effect in single-chip modes.

18.3.2.13 Reserved Register

Module Base + 0x000F

Starting address location affected by INITRG register setting.

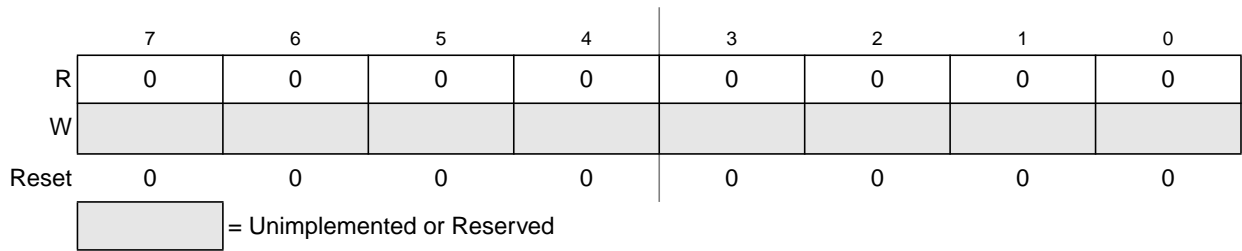

Figure 18-17. Reserved Register

This register location is not used (reserved). All bits in this register return logic 0s when read. Writes to this register have no effect.

This register is not in the on-chip memory map in expanded and special peripheral modes. Therefore, these accesses will be echoed externally.

18.3.2.14 IRQ Control Register (IRQCR)

Module Base + 0x001E

Starting address location affected by INITRG register setting.

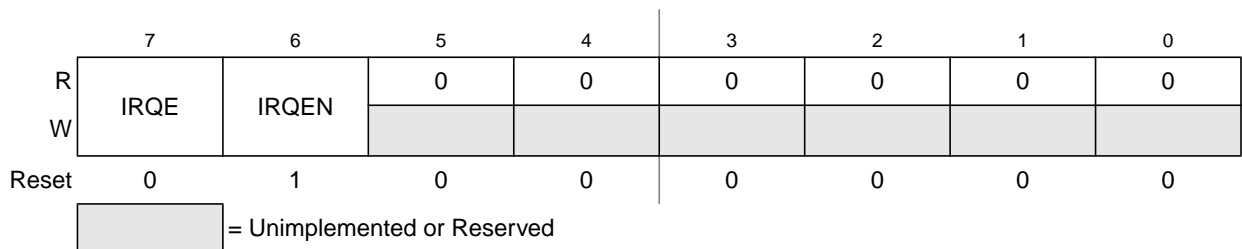

Figure 18-18. IRQ Control Register (IRQCR)

Read: See individual bit descriptions below

Write: See individual bit descriptions below

Table 18-12. IRQCR Field Descriptions

Field	Description
7 IRQE	IRQ Select Edge Sensitive Only Special modes: read or write anytime Normal and Emulation modes: read anytime, write once 0 IRQ configured for low level recognition. 1 IRQ configured to respond only to falling edges. Falling edges on the IRQ pin will be detected anytime IRQE = 1 and will be cleared only upon a reset or the servicing of the IRQ interrupt.
6 IRQEN	External IRQ Enable Normal, emulation, and special modes: read or write anytime 0 External IRQ pin is disconnected from interrupt logic. 1 External IRQ pin is connected to interrupt logic. Note: When IRQEN = 0, the edge detect latch is disabled.

18.3.2.15 Port K Data Register (PORTK)

Module Base + 0x0032

Starting address location affected by INITRG register setting.

	7	6	5	4	3	2	1	0
R	Bit 7	6	5	4	3	2	1	Bit 0
W								
Reset	0	0	0	0	0	0	0	0
Alternate Pin Function	$\overline{\text{ECS}}$	$\overline{\text{XCS}}$	XAB19	XAB18	XAB17	XAB16	XAB15	XAB14

Figure 18-19. Port K Data Register (PORTK)

Read: Anytime

Write: Anytime

This port is associated with the internal memory expansion emulation pins. When the port is not enabled to emulate the internal memory expansion, the port pins are used as general-purpose I/O. When port K is operating as a general-purpose I/O port, DDRK determines the primary direction for each port K pin. A 1 causes the associated port pin to be an output and a 0 causes the associated pin to be a high-impedance input. The value in a DDR bit also affects the source of data for reads of the corresponding PORTK register. If the DDR bit is 0 (input) the buffered pin input is read. If the DDR bit is 1 (output) the output of the port data register is read.

This register is not in the map in peripheral or expanded modes while the EMK control bit in MODE register is set. Therefore, these accesses will be echoed externally.

When inputs, these pins can be selected to be high impedance or pulled up, based upon the state of the PUPKE bit in the PUCR register.

Table 18-13. PORTK Field Descriptions

Field	Description
7 Port K, Bit 7	Port K, Bit 7 — This bit is used as an emulation chip select signal for the emulation of the internal memory expansion, or as general-purpose I/O, depending upon the state of the EMK bit in the MODE register. While this bit is used as a chip select, the external bit will return to its de-asserted state (V_{DD}) for approximately 1/4 cycle just after the negative edge of ECLK, unless the external access is stretched and ECLK is free-running (ESTR bit in EBICTL = 0). See the MMC block description chapter for additional details on when this signal will be active.
6 Port K, Bit 6	Port K, Bit 6 — This bit is used as an external chip select signal for most external accesses that are not selected by $\overline{\text{ECS}}$ (see the MMC block description chapter for more details), depending upon the state of the EMK bit in the MODE register. While this bit is used as a chip select, the external pin will return to its de-asserted state (V_{DD}) for approximately 1/4 cycle just after the negative edge of ECLK, unless the external access is stretched and ECLK is free-running (ESTR bit in EBICTL = 0).
5:0 Port K, Bits 5:0	Port K, Bits 5:0 — These six bits are used to determine which FLASH/ROM or external memory array page is being accessed. They can be viewed as expanded addresses XAB19–XAB14 of the 20-bit address used to access up to 1M byte internal FLASH/ROM or external memory array. Alternatively, these bits can be used for general-purpose I/O depending upon the state of the EMK bit in the MODE register.

18.3.2.16 Port K Data Direction Register (DDRK)

Module Base + 0x0033

Starting address location affected by INITRG register setting.

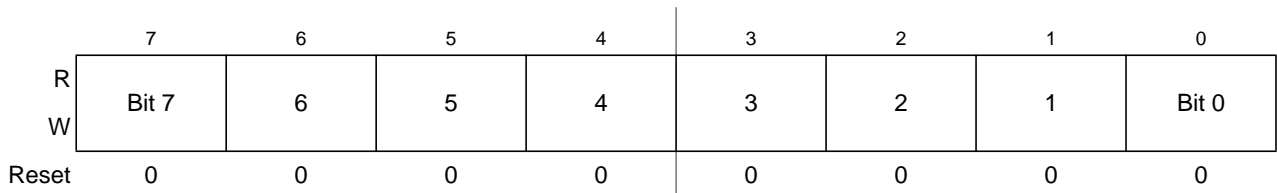

Figure 18-20. Port K Data Direction Register (DDRK)

Read: Anytime

Write: Anytime

This register determines the primary direction for each port K pin configured as general-purpose I/O. This register is not in the map in peripheral or expanded modes while the EMK control bit in MODE register is set. Therefore, these accesses will be echoed externally.

Table 18-14. EBICTL Field Descriptions

Field	Description
7:0 DDRK	<p>Data Direction Port K Bits</p> <p>0 Associated pin is a high-impedance input</p> <p>1 Associated pin is an output</p> <p>Note: It is unwise to write PORTK and DDRK as a word access. If you are changing port K pins from inputs to outputs, the data may have extra transitions during the write. It is best to initialize PORTK before enabling as outputs.</p> <p>Note: To ensure that you read the correct value from the PORTK pins, always wait at least one cycle after writing to the DDRK register before reading from the PORTK register.</p>

18.4 Functional Description

18.4.1 Detecting Access Type from External Signals

The external signals \overline{LSTRB} , R/\overline{W} , and $AB0$ indicate the type of bus access that is taking place. Accesses to the internal RAM module are the only type of access that would produce $\overline{LSTRB} = AB0 = 1$, because the internal RAM is specifically designed to allow misaligned 16-bit accesses in a single cycle. In these cases the data for the address that was accessed is on the low half of the data bus and the data for address + 1 is on the high half of the data bus. This is summarized in [Table 18-15](#).

Table 18-15. Access Type vs. Bus Control Pins

LSTRB	AB0	R/W	Type of Access
1	0	1	8-bit read of an even address
0	1	1	8-bit read of an odd address
1	0	0	8-bit write of an even address
0	1	0	8-bit write of an odd address

Table 18-15. Access Type vs. Bus Control Pins

LSTRB	AB0	R/W	Type of Access
0	0	1	16-bit read of an even address
1	1	1	16-bit read of an odd address (low/high data swapped)
0	0	0	16-bit write to an even address
1	1	0	16-bit write to an odd address (low/high data swapped)

18.4.2 Stretched Bus Cycles

In order to allow fast internal bus cycles to coexist in a system with slower external memory resources, the HCS12 supports the concept of stretched bus cycles (module timing reference clocks for timers and baud rate generators are not affected by this stretching). Control bits in the MISC register in the MMC sub-block of the core specify the amount of stretch (0, 1, 2, or 3 periods of the internal bus-rate clock). While stretching, the CPU state machines are all held in their current state. At this point in the CPU bus cycle, write data would already be driven onto the data bus so the length of time write data is valid is extended in the case of a stretched bus cycle. Read data would not be captured by the system until the E clock falling edge. In the case of a stretched bus cycle, read data is not required until the specified setup time before the falling edge of the stretched E clock. The chip selects, and R/\overline{W} signals remain valid during the period of stretching (throughout the stretched E high time).

NOTE

The address portion of the bus cycle is not stretched.

18.4.3 Modes of Operation

The operating mode out of reset is determined by the states of the MODC, MODB, and MODA pins during reset (Table 18-16). The MODC, MODB, and MODA bits in the MODE register show the current operating mode and provide limited mode switching during operation. The states of the MODC, MODB, and MODA pins are latched into these bits on the rising edge of the reset signal.

Table 18-16. Mode Selection

MODC	MODB	MODA	Mode Description
0	0	0	Special Single Chip, BDM allowed and ACTIVE. BDM is allowed in all other modes but a serial command is required to make BDM active.
0	0	1	Emulation Expanded Narrow, BDM allowed
0	1	0	Special Test (Expanded Wide), BDM allowed
0	1	1	Emulation Expanded Wide, BDM allowed
1	0	0	Normal Single Chip, BDM allowed
1	0	1	Normal Expanded Narrow, BDM allowed
1	1	0	Peripheral; BDM allowed but bus operations would cause bus conflicts (must not be used)
1	1	1	Normal Expanded Wide, BDM allowed

There are two basic types of operating modes:

1. **Normal** modes: Some registers and bits are protected against accidental changes.
2. **Special** modes: Allow greater access to protected control registers and bits for special purposes such as testing.

A system development and debug feature, background debug mode (BDM), is available in all modes. In special single-chip mode, BDM is active immediately after reset.

Some aspects of Port E are not mode dependent. Bit 1 of Port E is a general purpose input or the $\overline{\text{IRQ}}$ interrupt input. $\overline{\text{IRQ}}$ can be enabled by bits in the CPU's condition codes register but it is inhibited at reset so this pin is initially configured as a simple input with a pull-up. Bit 0 of Port E is a general purpose input or the $\overline{\text{XIRQ}}$ interrupt input. $\overline{\text{XIRQ}}$ can be enabled by bits in the CPU's condition codes register but it is inhibited at reset so this pin is initially configured as a simple input with a pull-up. The ESTR bit in the EBICTL register is set to one by reset in any user mode. This assures that the reset vector can be fetched even if it is located in an external slow memory device. The PE6/MODB/IPIPE1 and PE5/MODA/IPIPE0 pins act as high-impedance mode select inputs during reset.

The following paragraphs discuss the default bus setup and describe which aspects of the bus can be changed after reset on a per mode basis.

18.4.3.1 Normal Operating Modes

These modes provide three operating configurations. Background debug is available in all three modes, but must first be enabled for some operations by means of a BDM background command, then activated.

18.4.3.1.1 Normal Single-Chip Mode

There is no external expansion bus in this mode. All pins of Ports A, B and E are configured as general purpose I/O pins. Port E bits 1 and 0 are available as general purpose input only pins with internal pull resistors enabled. All other pins of Port E are bidirectional I/O pins that are initially configured as high-impedance inputs with internal pull resistors enabled. Ports A and B are configured as high-impedance inputs with their internal pull resistors disabled.

The pins associated with Port E bits 6, 5, 3, and 2 cannot be configured for their alternate functions IPIPE1, IPIPE0, $\overline{\text{LSTRB}}$, and $\text{R}/\overline{\text{W}}$ while the MCU is in single chip modes. In single chip modes, the associated control bits PIPOE, LSTRE, and RDWE are reset to zero. Writing the opposite state into them in single chip mode does not change the operation of the associated Port E pins.

In normal single chip mode, the MODE register is writable one time. This allows a user program to change the bus mode to narrow or wide expanded mode and/or turn on visibility of internal accesses.

Port E, bit 4 can be configured for a free-running E clock output by clearing NECLK=0. Typically the only use for an E clock output while the MCU is in single chip modes would be to get a constant speed clock for use in the external application system.

18.4.3.1.2 Normal Expanded Wide Mode

In expanded wide modes, Ports A and B are configured as a 16-bit multiplexed address and data bus and Port E bit 4 is configured as the E clock output signal. These signals allow external memory and peripheral devices to be interfaced to the MCU.

Port E pins other than PE4/ECLK are configured as general purpose I/O pins (initially high-impedance inputs with internal pull resistors enabled). Control bits PIPOE, NECLK, LSTRE, and RDWE in the PEAR register can be used to configure Port E pins to act as bus control outputs instead of general purpose I/O pins.

It is possible to enable the pipe status signals on Port E bits 6 and 5 by setting the PIPOE bit in PEAR, but it would be unusual to do so in this mode. Development systems where pipe status signals are monitored would typically use the special variation of this mode.

The Port E bit 2 pin can be reconfigured as the R/\overline{W} bus control signal by writing “1” to the RDWE bit in PEAR. If the expanded system includes external devices that can be written, such as RAM, the RDWE bit would need to be set before any attempt to write to an external location. If there are no writable resources in the external system, PE2 can be left as a general purpose I/O pin.

The Port E bit 3 pin can be reconfigured as the \overline{LSTRB} bus control signal by writing “1” to the LSTRE bit in PEAR. The default condition of this pin is a general purpose input because the \overline{LSTRB} function is not needed in all expanded wide applications.

The Port E bit 4 pin is initially configured as ECLK output with stretch. The E clock output function depends upon the settings of the NECLK bit in the PEAR register, the IVIS bit in the MODE register and the ESTR bit in the EBICTL register. The E clock is available for use in external select decode logic or as a constant speed clock for use in the external application system.

18.4.3.1.3 Normal Expanded Narrow Mode

This mode is used for lower cost production systems that use 8-bit wide external EPROMs or RAMs. Such systems take extra bus cycles to access 16-bit locations but this may be preferred over the extra cost of additional external memory devices.

Ports A and B are configured as a 16-bit address bus and Port A is multiplexed with data. Internal visibility is not available in this mode because the internal cycles would need to be split into two 8-bit cycles.

Since the PEAR register can only be written one time in this mode, use care to set all bits to the desired states during the single allowed write.

The PE3/ \overline{LSTRB} pin is always a general purpose I/O pin in normal expanded narrow mode. Although it is possible to write the LSTRE bit in PEAR to “1” in this mode, the state of LSTRE is overridden and Port E bit 3 cannot be reconfigured as the \overline{LSTRB} output.

It is possible to enable the pipe status signals on Port E bits 6 and 5 by setting the PIPOE bit in PEAR, but it would be unusual to do so in this mode. \overline{LSTRB} would also be needed to fully understand system activity. Development systems where pipe status signals are monitored would typically use special expanded wide mode or occasionally special expanded narrow mode.

The PE4/ECLK pin is initially configured as ECLK output with stretch. The E clock output function depends upon the settings of the NECLK bit in the PEAR register, the IVIS bit in the MODE register and the ESTR bit in the EBICTL register. In normal expanded narrow mode, the E clock is available for use in external select decode logic or as a constant speed clock for use in the external application system.

The PE2/R/W pin is initially configured as a general purpose input with an internal pull resistor enabled but this pin can be reconfigured as the R/\overline{W} bus control signal by writing “1” to the RDWE bit in PEAR. If the expanded narrow system includes external devices that can be written such as RAM, the RDWE bit would need to be set before any attempt to write to an external location. If there are no writable resources in the external system, PE2 can be left as a general purpose I/O pin.

18.4.3.1.4 Emulation Expanded Wide Mode

In expanded wide modes, Ports A and B are configured as a 16-bit multiplexed address and data bus and Port E provides bus control and status signals. These signals allow external memory and peripheral devices to be interfaced to the MCU. These signals can also be used by a logic analyzer to monitor the progress of application programs.

The bus control related pins in Port E (PE7/NOACC, PE6/MODB/IPIPE1, PE5/MODA/IPIPE0, PE4/ECLK, PE3/ $\overline{LSTRB}/\overline{TAGLO}$, and PE2/ R/\overline{W}) are all configured to serve their bus control output functions rather than general purpose I/O. Notice that writes to the bus control enable bits in the PEAR register in emulation mode are restricted.

18.4.3.1.5 Emulation Expanded Narrow Mode

Expanded narrow modes are intended to allow connection of single 8-bit external memory devices for lower cost systems that do not need the performance of a full 16-bit external data bus. Accesses to internal resources that have been mapped external (i.e. PORTA, PORTB, DDRA, DDRB, PORTE, DDRE, PEAR, PUCR, RDRIV) will be accessed with a 16-bit data bus on Ports A and B. Accesses of 16-bit external words to addresses which are normally mapped external will be broken into two separate 8-bit accesses using Port A as an 8-bit data bus. Internal operations continue to use full 16-bit data paths. They are only visible externally as 16-bit information if IVIS=1.

Ports A and B are configured as multiplexed address and data output ports. During external accesses, address A15, data D15 and D7 are associated with PA7, address A0 is associated with PB0 and data D8 and D0 are associated with PA0. During internal visible accesses and accesses to internal resources that have been mapped external, address A15 and data D15 is associated with PA7 and address A0 and data D0 is associated with PB0.

The bus control related pins in Port E (PE7/NOACC, PE6/MODB/IPIPE1, PE5/MODA/IPIPE0, PE4/ECLK, PE3/ $\overline{LSTRB}/\overline{TAGLO}$, and PE2/ R/\overline{W}) are all configured to serve their bus control output functions rather than general purpose I/O. Notice that writes to the bus control enable bits in the PEAR register in emulation mode are restricted.

The main difference between special modes and normal modes is that some of the bus control and system control signals cannot be written in emulation modes.

18.4.3.2 Special Operating Modes

There are two special operating modes that correspond to normal operating modes. These operating modes are commonly used in factory testing and system development.

18.4.3.2.1 Special Single-Chip Mode

When the MCU is reset in this mode, the background debug mode is enabled and active. The MCU does not fetch the reset vector and execute application code as it would in other modes. Instead the active background mode is in control of CPU execution and BDM firmware is waiting for additional serial commands through the BKGD pin. When a serial command instructs the MCU to return to normal execution, the system will be configured as described below unless the reset states of internal control registers have been changed through background commands after the MCU was reset.

There is no external expansion bus after reset in this mode. Ports A and B are initially simple bidirectional I/O pins that are configured as high-impedance inputs with internal pull resistors disabled; however, writing to the mode select bits in the MODE register (which is allowed in special modes) can change this after reset. All of the Port E pins (except PE4/ECLK) are initially configured as general purpose high-impedance inputs with internal pull resistors enabled. PE4/ECLK is configured as the E clock output in this mode.

The pins associated with Port E bits 6, 5, 3, and 2 cannot be configured for their alternate functions IPIPE1, IPIPE0, $\overline{\text{LSTRB}}$, and $\text{R}/\overline{\text{W}}$ while the MCU is in single chip modes. In single chip modes, the associated control bits PIPOE, LSTRE and RDWE are reset to zero. Writing the opposite value into these bits in single chip mode does not change the operation of the associated Port E pins.

Port E, bit 4 can be configured for a free-running E clock output by clearing NECLK=0. Typically the only use for an E clock output while the MCU is in single chip modes would be to get a constant speed clock for use in the external application system.

18.4.3.2.2 Special Test Mode

In expanded wide modes, Ports A and B are configured as a 16-bit multiplexed address and data bus and Port E provides bus control and status signals. In special test mode, the write protection of many control bits is lifted so that they can be thoroughly tested without needing to go through reset.

18.4.3.3 Test Operating Mode

There is a test operating mode in which an external master, such as an I.C. tester, can control the on-chip peripherals.

18.4.3.3.1 Peripheral Mode

This mode is intended for factory testing of the MCU. In this mode, the CPU is inactive and an external (tester) bus master drives address, data and bus control signals in through Ports A, B and E. In effect, the whole MCU acts as if it was a peripheral under control of an external CPU. This allows faster testing of on-chip memory and peripherals than previous testing methods. Since the mode control register is not accessible in peripheral mode, the only way to change to another mode is to reset the MCU into a different

mode. Background debugging should not be used while the MCU is in special peripheral mode as internal bus conflicts between BDM and the external master can cause improper operation of both functions.

18.4.4 Internal Visibility

Internal visibility is available when the MCU is operating in expanded wide modes or emulation narrow mode. It is not available in single-chip, peripheral or normal expanded narrow modes. Internal visibility is enabled by setting the IVIS bit in the MODE register.

If an internal access is made while E, R/\overline{W} , and \overline{LSTRB} are configured as bus control outputs and internal visibility is off (IVIS=0), E will remain low for the cycle, R/\overline{W} will remain high, and address, data and the \overline{LSTRB} pins will remain at their previous state.

When internal visibility is enabled (IVIS=1), certain internal cycles will be blocked from going external. During cycles when the BDM is selected, R/\overline{W} will remain high, data will maintain its previous state, and address and \overline{LSTRB} pins will be updated with the internal value. During CPU no access cycles when the BDM is not driving, R/\overline{W} will remain high, and address, data and the \overline{LSTRB} pins will remain at their previous state.

NOTE

When the system is operating in a secure mode, internal visibility is not available (i.e., IVIS = 1 has no effect). Also, the IPIPE signals will not be visible, regardless of operating mode. IPIPE1–IPIPE0 will display 0es if they are enabled. In addition, the MOD bits in the MODE control register cannot be written.

18.4.5 Low-Power Options

The MEBI does not contain any user-controlled options for reducing power consumption. The operation of the MEBI in low-power modes is discussed in the following subsections.

18.4.5.1 Operation in Run Mode

The MEBI does not contain any options for reducing power in run mode; however, the external addresses are conditioned to reduce power in single-chip modes. Expanded bus modes will increase power consumption.

18.4.5.2 Operation in Wait Mode

The MEBI does not contain any options for reducing power in wait mode.

18.4.5.3 Operation in Stop Mode

The MEBI will cease to function after execution of a CPU STOP instruction.

Chapter 19

Module Mapping Control (MMCV4) Block Description

19.1 Introduction

This section describes the functionality of the module mapping control (MMC) sub-block of the S12 core platform.

The block diagram of the MMC is shown in [Figure 19-1](#).

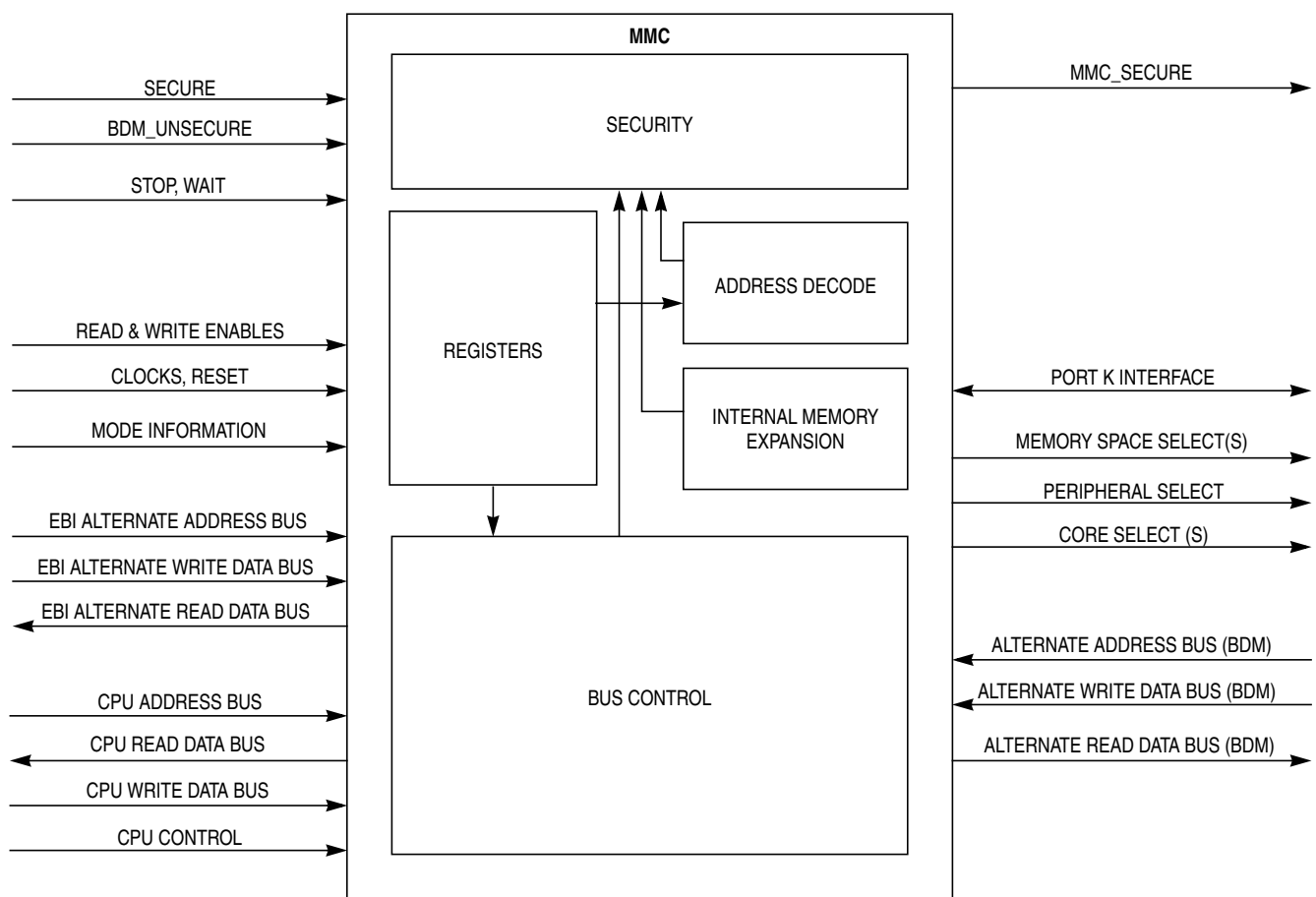

Figure 19-1. MMC Block Diagram

The MMC is the sub-module which controls memory map assignment and selection of internal resources and external space. Internal buses between the core and memories and between the core and peripherals is controlled in this module. The memory expansion is generated in this module.

19.1.1 Features

- Registers for mapping of address space for on-chip RAM, EEPROM, and FLASH (or ROM) memory blocks and associated registers
- Memory mapping control and selection based upon address decode and system operating mode
- Core address bus control
- Core data bus control and multiplexing
- Core security state decoding
- Emulation chip select signal generation (\overline{ECS})
- External chip select signal generation (\overline{XCS})
- Internal memory expansion
- External stretch and ROM mapping control functions via the MISC register
- Reserved registers for test purposes
- Configurable system memory options defined at integration of core into the system-on-a-chip (SoC).

19.1.2 Modes of Operation

Some of the registers operate differently depending on the mode of operation (i.e., normal expanded wide, special single chip, etc.). This is best understood from the register descriptions.

19.2 External Signal Description

All interfacing with the MMC sub-block is done within the core, it has no external signals.

19.3 Memory Map and Register Definition

A summary of the registers associated with the MMC sub-block is shown in [Figure 19-2](#). Detailed descriptions of the registers and bits are given in the subsections that follow.

19.3.1 Module Memory Map

Table 19-1. MMC Memory Map

Address Offset	Register	Access
0x0010	Initialization of Internal RAM Position Register (INITRM)	R/W
0x0011	Initialization of Internal Registers Position Register (INITRG)	R/W
0x0012	Initialization of Internal EEPROM Position Register (INITEE)	R/W
0x0013	Miscellaneous System Control Register (MISC)	R/W
0x0014	Reserved	—
⋮	⋮	—

Table 19-1. MMC Memory Map (continued)

Address Offset	Register	Access
0x0017	Reserved	—
.	.	—
0x001C	Memory Size Register 0 (MEMSIZ0)	R
0x001D	Memory Size Register 1 (MEMSIZ1)	R
.	.	
0x0030	Program Page Index Register (PPAGE)	R/W
0x0031	Reserved	—

19.3.2 Register Descriptions

Name		Bit 7	6	5	4	3	2	1	Bit 0
0x0010 INITRM	R	RAM15	RAM14	RAM13	RAM12	RAM11	0	0	RAMHAL
	W								
0x0011 INITRG	R	0	REG14	REG13	REG12	REG11	0	0	0
	W								
0x0012 INITEE	R	EE15	EE14	EE13	EE12	EE11	0	0	EEON
	W								
0x0013 MISC	R	0	0	0	0	EXSTR1	EXSTR0	ROMHM	ROMON
	W								
0x0014 MTSTO	R	Bit 7	6	5	4	3	2	1	Bit 0
	W								
0x0017 MTST1	R	Bit 7	6	5	4	3	2	1	Bit 0
	W								
0x001C MEMSIZ0	R	REG_SW0	0	EED_SW1	EED_SW0	0	RAM_SW2	RAM_SW1	RAM_SW0
	W								
0x001D MEMSIZ1	R	ROM_SW1	ROM_SW0	0	0	0	0	PAG_SW1	PAG_SW0
	W								
0x0030 PPAGE	R	0	0	PIX5	PIX4	PIX3	PIX2	PIX1	PIX0
	W								
0x0031 Reserved	R	0	0	0	0	0	0	0	0
	W								

 = Unimplemented

Figure 19-2. MMC Register Summary

19.3.2.1 Initialization of Internal RAM Position Register (INITRM)

Module Base + 0x0010

Starting address location affected by INITRG register setting.

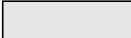
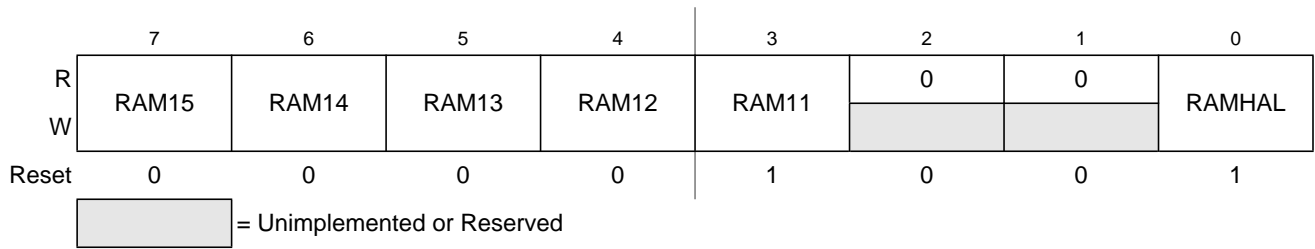

Figure 19-3. Initialization of Internal RAM Position Register (INITRM)

Read: Anytime

Write: Once in normal and emulation modes, anytime in special modes

NOTE

Writes to this register take one cycle to go into effect.

This register initializes the position of the internal RAM within the on-chip system memory map.

Table 19-2. INITRM Field Descriptions

Field	Description
7:3 RAM[15:11]	Internal RAM Map Position — These bits determine the upper five bits of the base address for the system's internal RAM array.
0 RAMHAL	RAM High-Align — RAMHAL specifies the alignment of the internal RAM array. 0 Aligns the RAM to the lowest address (0x0000) of the mappable space 1 Aligns the RAM to the higher address (0xFFFF) of the mappable space

19.3.2.2 Initialization of Internal Registers Position Register (INITRG)

Module Base + 0x0011

Starting address location affected by INITRG register setting.

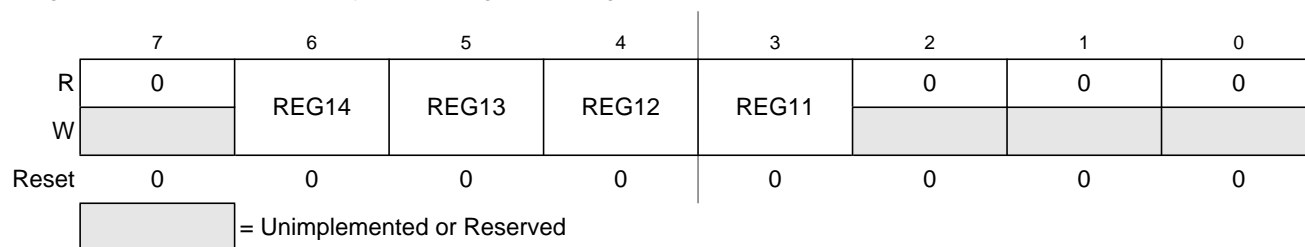

Figure 19-4. Initialization of Internal Registers Position Register (INITRG)

Read: Anytime

Write: Once in normal and emulation modes and anytime in special modes

This register initializes the position of the internal registers within the on-chip system memory map. The registers occupy either a 1K byte or 2K byte space and can be mapped to any 2K byte space within the first 32K bytes of the system’s address space.

Table 19-3. INITRG Field Descriptions

Field	Description
6:3 REG[14:11]	Internal Register Map Position — These four bits in combination with the leading zero supplied by bit 7 of INITRG determine the upper five bits of the base address for the system’s internal registers (i.e., the minimum base address is 0x0000 and the maximum is 0x7FFF).

19.3.2.3 Initialization of Internal EEPROM Position Register (INITEE)

Module Base + 0x0012

Starting address location affected by INITRG register setting.

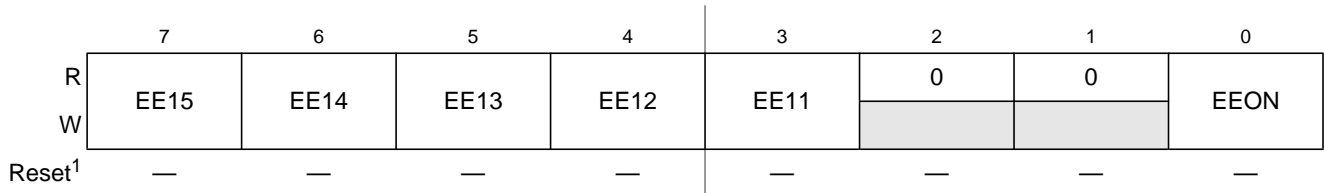

1. The reset state of this register is controlled at chip integration. Please refer to the device overview section to determine the actual reset state of this register.

= Unimplemented or Reserved

Figure 19-5. Initialization of Internal EEPROM Position Register (INITEE)

Read: Anytime

Write: The EEON bit can be written to any time on all devices. Bits E[11:15] are “write anytime in all modes” on most devices. On some devices, bits E[11:15] are “write once in normal and emulation modes and write anytime in special modes”. See device overview chapter to determine the actual write access rights.

NOTE

Writes to this register take one cycle to go into effect.

This register initializes the position of the internal EEPROM within the on-chip system memory map.

Table 19-4. INITEE Field Descriptions

Field	Description
7:3 EE[15:11]	Internal EEPROM Map Position — These bits determine the upper five bits of the base address for the system's internal EEPROM array.
0 EEON	Enable EEPROM — This bit is used to enable the EEPROM memory in the memory map. 0 Disables the EEPROM from the memory map. 1 Enables the EEPROM in the memory map at the address selected by EE[15:11].

19.3.2.4 Miscellaneous System Control Register (MISC)

Module Base + 0x0013

Starting address location affected by INITRG register setting.

	7	6	5	4	3	2	1	0
R	0	0	0	0	EXSTR1	EXSTR0	ROMHM	ROMON
W								
Reset: Expanded or Emulation	0	0	0	0	1	1	0	— ¹
Reset: Peripheral or Single Chip	0	0	0	0	1	1	0	1
Reset: Special Test	0	0	0	0	1	1	0	0

1. The reset state of this bit is determined at the chip integration level.

= Unimplemented or Reserved

Figure 19-6. Miscellaneous System Control Register (MISC)

Read: Anytime

Write: As stated in each bit description

NOTE

Writes to this register take one cycle to go into effect.

This register initializes miscellaneous control functions.

Table 19-5. INITEE Field Descriptions

Field	Description
3:2 EXSTR[1:0]	External Access Stretch Bits 1 and 0 Write: once in normal and emulation modes and anytime in special modes This two-bit field determines the amount of clock stretch on accesses to the external address space as shown in Table 19-6 . In single chip and peripheral modes these bits have no meaning or effect.
1 ROMHM	FLASH EEPROM or ROM Only in Second Half of Memory Map Write: once in normal and emulation modes and anytime in special modes 0 The fixed page(s) of FLASH EEPROM or ROM in the lower half of the memory map can be accessed. 1 Disables direct access to the FLASH EEPROM or ROM in the lower half of the memory map. These physical locations of the FLASH EEPROM or ROM remain accessible through the program page window.
0 ROMON	ROMON — Enable FLASH EEPROM or ROM Write: once in normal and emulation modes and anytime in special modes This bit is used to enable the FLASH EEPROM or ROM memory in the memory map. 0 Disables the FLASH EEPROM or ROM from the memory map. 1 Enables the FLASH EEPROM or ROM in the memory map.

Table 19-6. External Stretch Bit Definition

Stretch Bit EXSTR1	Stretch Bit EXSTR0	Number of E Clocks Stretched
0	0	0
0	1	1
1	0	2
1	1	3

19.3.2.5 Reserved Test Register 0 (MTST0)

Module Base + 0x0014

Starting address location affected by INITRG register setting.

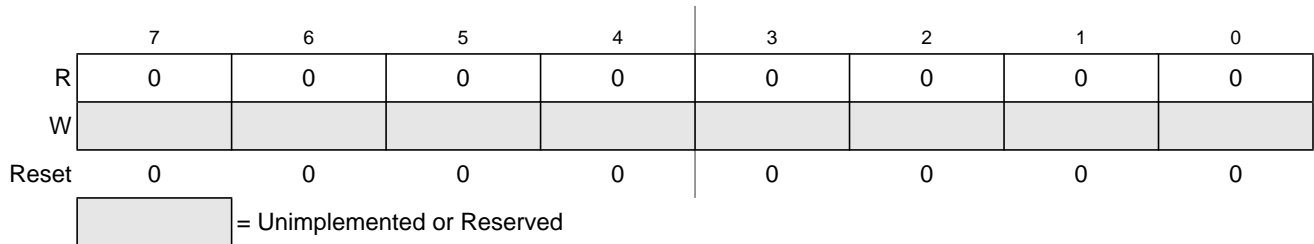

Figure 19-7. Reserved Test Register 0 (MTST0)

Read: Anytime

Write: No effect — this register location is used for internal test purposes.

19.3.2.6 Reserved Test Register 1 (MTST1)

Module Base + 0x0017

Starting address location affected by INITRG register setting.

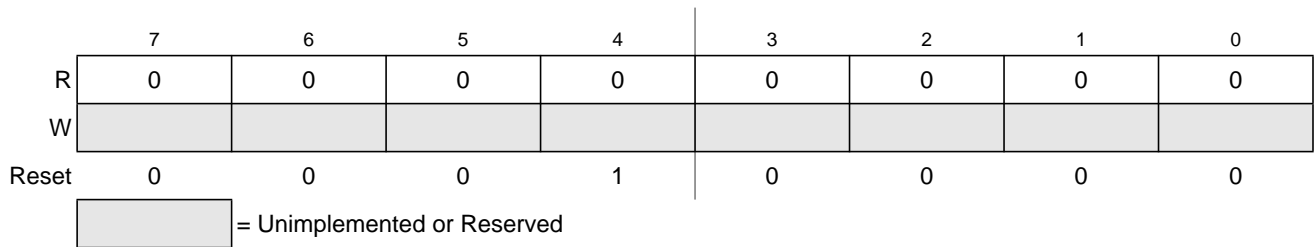

Figure 19-8. Reserved Test Register 1 (MTST1)

Read: Anytime

Write: No effect — this register location is used for internal test purposes.

19.3.2.7 Memory Size Register 0 (MEMSIZ0)

Module Base + 0x001C

Starting address location affected by INITRG register setting.

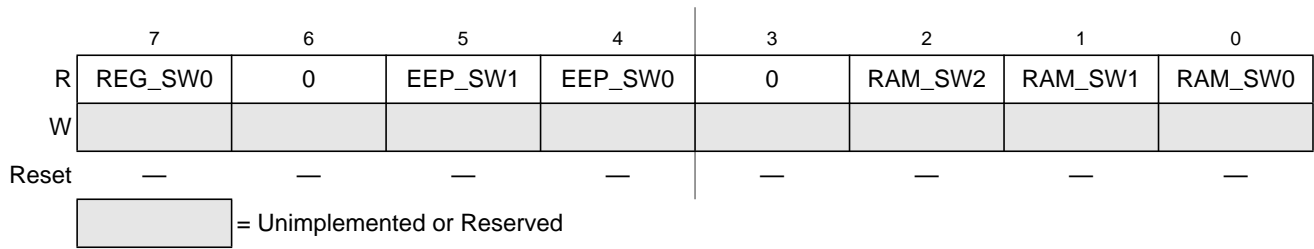

Figure 19-9. Memory Size Register 0 (MEMSIZ0)

Read: Anytime

Write: Writes have no effect

Reset: Defined at chip integration, see device overview section.

The MEMSIZ0 register reflects the state of the register, EEPROM and RAM memory space configuration switches at the core boundary which are configured at system integration. This register allows read visibility to the state of these switches.

Table 19-7. MEMSIZ0 Field Descriptions

Field	Description
7 REG_SW0	Allocated System Register Space 0 Allocated system register space size is 1K byte 1 Allocated system register space size is 2K byte
5:4 EEP_SW[1:0]	Allocated System EEPROM Memory Space — The allocated system EEPROM memory space size is as given in Table 19-8 .
2 RAM_SW[2:0]	Allocated System RAM Memory Space — The allocated system RAM memory space size is as given in Table 19-9 .

Table 19-8. Allocated EEPROM Memory Space

eep_sw1:eep_sw0	Allocated EEPROM Space
00	0K byte
01	2K bytes
10	4K bytes
11	8K bytes

Table 19-9. Allocated RAM Memory Space

ram_sw2:ram_sw0	Allocated RAM Space	RAM Mappable Region	INITRM Bits Used	RAM Reset Base Address ¹
000	2K bytes	2K bytes	RAM[15:11]	0x0800
001	4K bytes	4K bytes	RAM[15:12]	0x0000
010	6K bytes	8K bytes ²	RAM[15:13]	0x0800

Table 19-9. Allocated RAM Memory Space (continued)

ram_sw2:ram_sw0	Allocated RAM Space	RAM Mappable Region	INITRM Bits Used	RAM Reset Base Address ¹
011	8K bytes	8K bytes	RAM[15:13]	0x0000
100	10K bytes	16K bytes ²	RAM[15:14]	0x1800
101	12K bytes	16K bytes ²	RAM[15:14]	0x1000
110	14K bytes	16K bytes ²	RAM[15:14]	0x0800
111	16K bytes	16K bytes	RAM[15:14]	0x0000

¹ The RAM Reset BASE Address is based on the reset value of the INITRM register, 0x0009.

² Alignment of the Allocated RAM space within the RAM mappable region is dependent on the value of RAMHAL.

NOTE

As stated, the bits in this register provide read visibility to the system physical memory space allocations defined at system integration. The actual array size for any given type of memory block may differ from the allocated size. Please refer to the device overview chapter for actual sizes.

19.3.2.8 Memory Size Register 1 (MEMSIZ1)

Module Base + 0x001D

Starting address location affected by INITRG register setting.

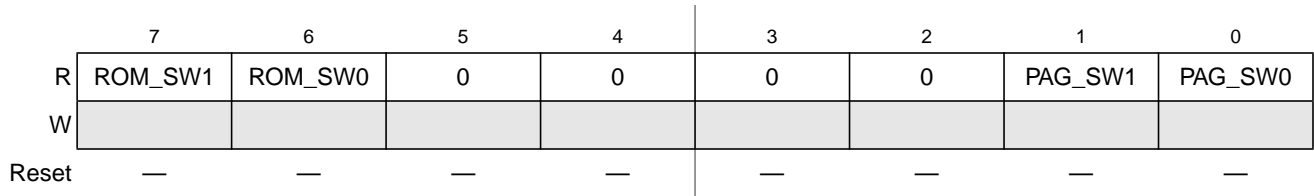

 = Unimplemented or Reserved

Figure 19-10. Memory Size Register 1 (MEMSIZ1)

Read: Anytime

Write: Writes have no effect

Reset: Defined at chip integration, see device overview section.

The MEMSIZ1 register reflects the state of the FLASH or ROM physical memory space and paging switches at the core boundary which are configured at system integration. This register allows read visibility to the state of these switches.

Table 19-10. MEMSIZ0 Field Descriptions

Field	Description
7:6 ROM_SW[1:0]	Allocated System FLASH or ROM Physical Memory Space — The allocated system FLASH or ROM physical memory space is as given in Table 19-11 .
1:0 PAG_SW[1:0]	Allocated Off-Chip FLASH or ROM Memory Space — The allocated off-chip FLASH or ROM memory space size is as given in Table 19-12 .

Table 19-11. Allocated FLASH/ROM Physical Memory Space

rom_sw1:rom_sw0	Allocated FLASH or ROM Space
00	0K byte
01	16K bytes
10	48K bytes ⁽¹⁾
11	64K bytes ⁽¹⁾

NOTES:

- The ROMHM software bit in the MISC register determines the accessibility of the FLASH/ROM memory space. Please refer to [Section 19.3.2.8, “Memory Size Register 1 \(MEMSIZ1\)”](#), for a detailed functional description of the ROMHM bit.

Table 19-12. Allocated Off-Chip Memory Options

pag_sw1:pag_sw0	Off-Chip Space	On-Chip Space
00	876K bytes	128K bytes
01	768K bytes	256K bytes
10	512K bytes	512K bytes
11	0K byte	1M byte

NOTE

As stated, the bits in this register provide read visibility to the system memory space and on-chip/off-chip partitioning allocations defined at system integration. The actual array size for any given type of memory block may differ from the allocated size. Please refer to the device overview chapter for actual sizes.

19.3.2.9 Program Page Index Register (PPAGE)

Module Base + 0x0030

Starting address location affected by INITRG register setting.

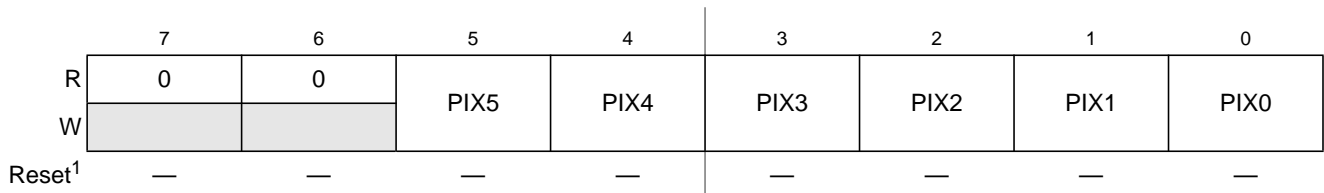

1. The reset state of this register is controlled at chip integration. Please refer to the device overview section to determine the actual reset state of this register.

= Unimplemented or Reserved

Figure 19-11. Program Page Index Register (PPAGE)

Read: Anytime

Write: Determined at chip integration. Generally it’s: “write anytime in all modes;” on some devices it will be: “write only in special modes.” Check specific device documentation to determine which applies.

Reset: Defined at chip integration as either 0x00 (paired with write in any mode) or 0x3C (paired with write only in special modes), see device overview chapter.

The HCS12 core architecture limits the physical address space available to 64K bytes. The program page index register allows for integrating up to 1M byte of FLASH or ROM into the system by using the six page index bits to page 16K byte blocks into the program page window located from 0x8000 to 0xBFFF as defined in [Table 19-14](#). CALL and RTC instructions have special access to read and write this register without using the address bus.

NOTE

Normal writes to this register take one cycle to go into effect. Writes to this register using the special access of the CALL and RTC instructions will be complete before the end of the associated instruction.

Table 19-13. MEMSIZ0 Field Descriptions

Field	Description
5:0 PIX[5:0]	Program Page Index Bits 5:0 — These page index bits are used to select which of the 64 FLASH or ROM array pages is to be accessed in the program page window as shown in Table 19-14 .

Table 19-14. Program Page Index Register Bits

PIX5	PIX4	PIX3	PIX2	PIX1	PIX0	Program Space Selected
0	0	0	0	0	0	16K page 0
0	0	0	0	0	1	16K page 1
0	0	0	0	1	0	16K page 2
0	0	0	0	1	1	16K page 3
.
.
.
.
.
1	1	1	1	0	0	16K page 60
1	1	1	1	0	1	16K page 61
1	1	1	1	1	0	16K page 62
1	1	1	1	1	1	16K page 63

19.4 Functional Description

The MMC sub-block performs four basic functions of the core operation: bus control, address decoding and select signal generation, memory expansion, and security decoding for the system. Each aspect is described in the following subsections.

19.4.1 Bus Control

The MMC controls the address bus and data buses that interface the core with the rest of the system. This includes the multiplexing of the input data buses to the core onto the main CPU read data bus and control of data flow from the CPU to the output address and data buses of the core. In addition, the MMC manages all CPU read data bus swapping operations.

19.4.2 Address Decoding

As data flows on the core address bus, the MMC decodes the address information, determines whether the internal core register or firmware space, the peripheral space or a memory register or array space is being addressed and generates the correct select signal. This decoding operation also interprets the mode of operation of the system and the state of the mapping control registers in order to generate the proper select. The MMC also generates two external chip select signals, emulation chip select (\overline{ECS}) and external chip select (\overline{XCS}).

19.4.2.1 Select Priority and Mode Considerations

Although internal resources such as control registers and on-chip memory have default addresses, each can be relocated by changing the default values in control registers. Normally, I/O addresses, control registers,

vector spaces, expansion windows, and on-chip memory are mapped so that their address ranges do not overlap. The MMC will make only one select signal active at any given time. This activation is based upon the priority outlined in [Table 19-15](#). If two or more blocks share the same address space, only the select signal for the block with the highest priority will become active. An example of this is if the registers and the RAM are mapped to the same space, the registers will have priority over the RAM and the portion of RAM mapped in this shared space will not be accessible. The expansion windows have the lowest priority. This means that registers, vectors, and on-chip memory are always visible to a program regardless of the values in the page select registers.

Table 19-15. Select Signal Priority

Priority	Address Space
Highest	BDM (internal to core) firmware or register space
...	Internal register space
...	RAM memory block
...	EEPROM memory block
...	On-chip FLASH or ROM
Lowest	Remaining external space

In expanded modes, all address space not used by internal resources is by default external memory space. The data registers and data direction registers for ports A and B are removed from the on-chip memory map and become external accesses. If the EME bit in the MODE register (see MEBI block description chapter) is set, the data and data direction registers for port E are also removed from the on-chip memory map and become external accesses.

In special peripheral mode, the first 16 registers associated with bus expansion are removed from the on-chip memory map (PORTA, PORTB, DDRA, DDRB, PORTE, DDRE, PEAR, MODE, PUCR, RDRIV, and the EBI reserved registers).

In emulation modes, if the EMK bit in the MODE register (see MEBI block description chapter) is set, the data and data direction registers for port K are removed from the on-chip memory map and become external accesses.

19.4.2.2 Emulation Chip Select Signal

When the EMK bit in the MODE register (see MEBI block description chapter) is set, port K bit 7 is used as an active-low emulation chip select signal, \overline{ECS} . This signal is active when the system is in emulation mode, the EMK bit is set and the FLASH or ROM space is being addressed subject to the conditions outlined in [Section 19.4.3.2, “Extended Address \(XAB19:14\) and ECS Signal Functionality.”](#) When the EMK bit is clear, this pin is used for general purpose I/O.

19.4.2.3 External Chip Select Signal

When the EMK bit in the MODE register (see MEBI block description chapter) is set, port K bit 6 is used as an active-low external chip select signal, \overline{XCS} . This signal is active only when the \overline{ECS} signal described above is not active and when the system is addressing the external address space. Accesses to

unimplemented locations within the register space or to locations that are removed from the map (i.e., ports A and B in expanded modes) will not cause this signal to become active. When the EMK bit is clear, this pin is used for general purpose I/O.

19.4.3 Memory Expansion

The HCS12 core architecture limits the physical address space available to 64K bytes. The program page index register allows for integrating up to 1M byte of FLASH or ROM into the system by using the six page index bits to page 16K byte blocks into the program page window located from 0x8000 to 0xBFFF in the physical memory space. The paged memory space can consist of solely on-chip memory or a combination of on-chip and off-chip memory. This partitioning is configured at system integration through the use of the paging configuration switches (*pag_sw1:pag_sw0*) at the core boundary. The options available to the integrator are as given in [Table 19-16](#) (this table matches [Table 19-12](#) but is repeated here for easy reference).

Table 19-16. Allocated Off-Chip Memory Options

pag_sw1:pag_sw0	Off-Chip Space	On-Chip Space
00	876K bytes	128K bytes
01	768K bytes	256K bytes
10	512K bytes	512K bytes
11	0K byte	1M byte

Based upon the system configuration, the program page window will consider its access to be either internal or external as defined in [Table 19-17](#).

Table 19-17. External/Internal Page Window Access

pag_sw1:pag_sw0	Partitioning	PIX5:0 Value	Page Window Access
00	876K off-Chip, 128K on-Chip	0x0000–0x0037	External
		0x0038–0x003F	Internal
01	768K off-chip, 256K on-chip	0x0000–0x002F	External
		0x0030–0x003F	Internal
10	512K off-chip, 512K on-chip	0x0000–0x001F	External
		0x0020–0x003F	Internal
11	0K off-chip, 1M on-chip	N/A	External
		0x0000–0x003F	Internal

NOTE

The partitioning as defined in [Table 19-17](#) applies only to the allocated memory space and the actual on-chip memory sizes implemented in the system may differ. Please refer to the device overview chapter for actual sizes.

The PPAGE register holds the page select value for the program page window. The value of the PPAGE register can be manipulated by normal read and write (some devices don't allow writes in some modes) instructions as well as the CALL and RTC instructions.

Control registers, vector spaces, and a portion of on-chip memory are located in unpagged portions of the 64K byte physical address space. The stack and I/O addresses should also be in unpagged memory to make them accessible from any page.

The starting address of a service routine must be located in unpagged memory because the 16-bit exception vectors cannot point to addresses in pagged memory. However, a service routine can call other routines that are in pagged memory. The upper 16K byte block of memory space (0xC000–0xFFFF) is unpagged. It is recommended that all reset and interrupt vectors point to locations in this area.

19.4.3.1 CALL and Return from Call Instructions

CALL and RTC are uninterruptable instructions that automate page switching in the program expansion window. CALL is similar to a JSR instruction, but the subroutine that is called can be located anywhere in the normal 64K byte address space or on any page of program expansion memory. CALL calculates and stacks a return address, stacks the current PPAGE value, and writes a new instruction-supplied value to PPAGE. The PPAGE value controls which of the 64 possible pages is visible through the 16K byte expansion window in the 64K byte memory map. Execution then begins at the address of the called subroutine.

During the execution of a CALL instruction, the CPU:

- Writes the old PPAGE value into an internal temporary register and writes the new instruction-supplied PPAGE value into the PPAGE register.
- Calculates the address of the next instruction after the CALL instruction (the return address), and pushes this 16-bit value onto the stack.
- Pushes the old PPAGE value onto the stack.
- Calculates the effective address of the subroutine, refills the queue, and begins execution at the new address on the selected page of the expansion window.

This sequence is uninterruptable; there is no need to inhibit interrupts during CALL execution. A CALL can be performed from any address in memory to any other address.

The PPAGE value supplied by the instruction is part of the effective address. For all addressing mode variations except indexed-indirect modes, the new page value is provided by an immediate operand in the instruction. In indexed-indirect variations of CALL, a pointer specifies memory locations where the new page value and the address of the called subroutine are stored. Using indirect addressing for both the new page value and the address within the page allows values calculated at run time rather than immediate values that must be known at the time of assembly.

The RTC instruction terminates subroutines invoked by a CALL instruction. RTC unstacks the PPAGE value and the return address and refills the queue. Execution resumes with the next instruction after the CALL.

During the execution of an RTC instruction, the CPU:

- Pulls the old PPAGE value from the stack
- Pulls the 16-bit return address from the stack and loads it into the PC
- Writes the old PPAGE value into the PPAGE register
- Refills the queue and resumes execution at the return address

This sequence is uninterruptable; an RTC can be executed from anywhere in memory, even from a different page of extended memory in the expansion window.

The CALL and RTC instructions behave like JSR and RTS, except they use more execution cycles. Therefore, routinely substituting CALL/RTC for JSR/RTS is not recommended. JSR and RTS can be used to access subroutines that are on the same page in expanded memory. However, a subroutine in expanded memory that can be called from other pages must be terminated with an RTC. And the RTC unstacks a PPAGE value. So any access to the subroutine, even from the same page, must use a CALL instruction so that the correct PPAGE value is in the stack.

19.4.3.2 Extended Address (XAB19:14) and $\overline{\text{ECS}}$ Signal Functionality

If the EMK bit in the MODE register is set (see MEBI block description chapter) the PIX5:0 values will be output on XAB19:14 respectively (port K bits 5:0) when the system is addressing within the physical program page window address space (0x8000–0xBFFF) and is in an expanded mode. When addressing anywhere else within the physical address space (outside of the paging space), the XAB19:14 signals will be assigned a constant value based upon the physical address space selected. In addition, the active-low emulation chip select signal, $\overline{\text{ECS}}$, will likewise function based upon the assigned memory allocation. In the cases of 48K byte and 64K byte allocated physical FLASH/ROM space, the operation of the $\overline{\text{ECS}}$ signal will additionally depend upon the state of the ROMHM bit (see Section 19.3.2.4, “Miscellaneous System Control Register (MISC)”) in the MISC register. Table 19-18, Table 19-19, Table 19-20, and Table 19-21 summarize the functionality of these signals based upon the allocated memory configuration. Again, this signal information is only available externally when the EMK bit is set and the system is in an expanded mode.

Table 19-18. 0K Byte Physical FLASH/ROM Allocated

Address Space	Page Window Access	ROMHM	ECS	XAB19:14
0x0000–0x3FFF	N/A	N/A	1	0x3D
0x4000–0x7FFF	N/A	N/A	1	0x3E
0x8000–0xBFFF	N/A	N/A	0	PIX[5:0]
0xC000–0xFFFF	N/A	N/A	0	0x3F

Table 19-19. 16K Byte Physical FLASH/ROM Allocated

Address Space	Page Window Access	ROMHM	ECS	XAB19:14
0x0000–0x3FFF	N/A	N/A	1	0x3D
0x4000–0x7FFF	N/A	N/A	1	0x3E
0x8000–0xBFFF	N/A	N/A	1	PIX[5:0]
0xC000–0xFFFF	N/A	N/A	0	0x3F

Table 19-20. 48K Byte Physical FLASH/ROM Allocated

Address Space	Page Window Access	ROMHM	ECS	XAB19:14
0x0000–0x3FFF	N/A	N/A	1	0x3D
0x4000–0x7FFF	N/A	0	0	0x3E
	N/A	1	1	
0x8000–0xBFFF	External	N/A	1	PIX[5:0]
	Internal	N/A	0	
0xC000–0xFFFF	N/A	N/A	0	0x3F

Table 19-21. 64K Byte Physical FLASH/ROM Allocated

Address Space	Page Window Access	ROMHM	ECS	XAB19:14
0x0000–0x3FFF	N/A	0	0	0x3D
	N/A	1	1	
0x4000–0x7FFF	N/A	0	0	0x3E
	N/A	1	1	
0x8000–0xBFFF	External	N/A	1	PIX[5:0]
	Internal	N/A	0	
0xC000–0xFFFF	N/A	N/A	0	0x3F

A graphical example of a memory paging for a system configured as 1M byte on-chip FLASH/ROM with 64K allocated physical space is given in Figure 19-12.

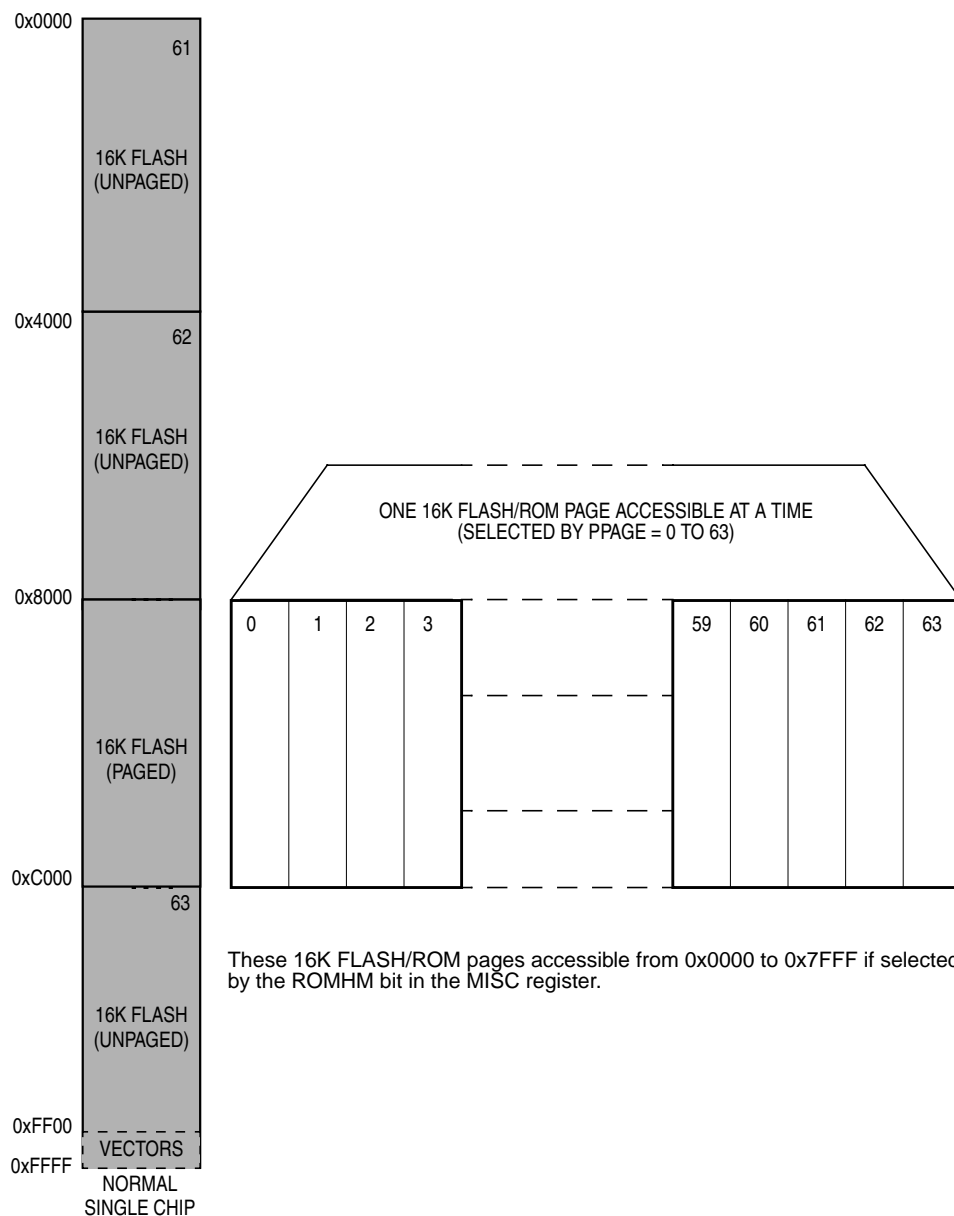

Figure 19-12. Memory Paging Example: 1M Byte On-Chip FLASH/ROM, 64K Allocation

Appendix A

Electrical Characteristics

A.1 General

NOTE

The electrical characteristics given in this section are preliminary and should be used as a guide only. Values cannot be guaranteed by Freescale and are subject to change without notice.

The part is specified and tested over the 5V and 3.3V ranges. For the intermediate range, generally the electrical specifications for the 3.3V range apply, but the part is not tested in production test in the intermediate range.

This supplement contains the most accurate electrical information for the MC9S12E-Family microcontroller available at the time of publication. The information should be considered **PRELIMINARY** and is subject to change.

This introduction is intended to give an overview on several common topics like power supply, current injection etc.

A.1.1 Parameter Classification

The electrical parameters shown in this supplement are guaranteed by various methods. To give the customer a better understanding the following classification is used and the parameters are tagged accordingly in the tables where appropriate.

NOTE

This classification will be added at a later release of the specification

- P: Those parameters are guaranteed during production testing on each individual device.
- C: Those parameters are achieved by the design characterization by measuring a statistically relevant sample size across process variations. They are regularly verified by production monitors.
- T: Those parameters are achieved by design characterization on a small sample size from typical devices. All values shown in the typical column are within this category.
- D: Those parameters are derived mainly from simulations.

A.1.2 Power Supply

The MC9S12E-Family utilizes several pins to supply power to the I/O ports, A/D converter, oscillator, PLL and internal logic.

The VDDA, VSSA pair supplies the A/D converter and D/A converter.

The VDDX, VSSX pair supplies the I/O pins

The VDDR, VSSR pair supplies the internal voltage regulator.

VDD1, VSS1, VDD2 and VSS2 are the supply pins for the internal logic.

VDDPLL, VSSPLL supply the oscillator and the PLL.

VSS1 and VSS2 are internally connected by metal.

VDD1 and VDD2 are internally connected by metal.

VDDA, VDDX, VDDR as well as VSSA, VSSX, VSSR are connected by anti-parallel diodes for ESD protection.

NOTE

In the following context VDD5 is used for either VDDA, VDDR and VDDX; VSS5 is used for either VSSA, VSSR and VSSX unless otherwise noted.

IDD5 denotes the sum of the currents flowing into the VDDA, VDDX and VDDR pins.

VDD is used for VDD1, VDD2 and VDDPLL, VSS is used for VSS1, VSS2 and VSSPLL.

IDD is used for the sum of the currents flowing into VDD1 and VDD2.

A.1.3 Pins

There are four groups of functional pins.

A.1.3.1 3.3V/5V I/O Pins

Those I/O pins have a nominal level of 3.3V or 5V depending on the application operating point. This group of pins is comprised of all port I/O pins, the analog inputs, BKGD pin and the RESET inputs. The internal structure of all those pins is identical, however some of the functionality may be disabled.

A.1.3.2 Analog Reference

This group of pins is comprised of the VRH and VRL pins.

A.1.3.3 Oscillator

The pins XFC, EXTAL, XTAL dedicated to the oscillator have a nominal 2.5V level. They are supplied by VDDPLL.

A.1.3.4 TEST

This pin is used for production testing only.

A.1.4 Current Injection

Power supply must maintain regulation within operating V_{DD5} or V_{DD} range during instantaneous and operating maximum current conditions. If positive injection current ($V_{in} > V_{DD5}$) is greater than I_{DD5} , the injection current may flow out of V_{DD5} and could result in external power supply going out of regulation. Insure external V_{DD5} load will shunt current greater than maximum injection current. This will be the greatest risk when the MCU is not consuming power; e.g. if no system clock is present, or if clock rate is very low which would reduce overall power consumption.

A.1.5 Absolute Maximum Ratings

Absolute maximum ratings are stress ratings only. A functional operation under or outside those maxima is not guaranteed. Stress beyond those limits may affect the reliability or cause permanent damage of the device.

This device contains circuitry protecting against damage due to high static voltage or electrical fields; however, it is advised that normal precautions be taken to avoid application of any voltages higher than maximum-rated voltages to this high-impedance circuit. Reliability of operation is enhanced if unused inputs are tied to an appropriate logic voltage level (e.g., either V_{SS5} or V_{DD5}).

Table A-1. Absolute Maximum Ratings

Num	Rating	Symbol	Min	Max	Unit
1	I/O, Regulator and Analog Supply Voltage	V_{DD5}	-0.3	6.5	V
2	Internal Logic Supply Voltage ¹	V_{DD}	-0.3	3.0	V
3	PLL Supply Voltage ¹	V_{DDPLL}	-0.3	3.0	V
4	Voltage difference VDDX to VDDR and VDDA	ΔV_{DDX}	-0.3	0.3	V
5	Voltage difference VSSX to VSSR and VSSA	ΔV_{SSX}	-0.3	0.3	V
6	Digital I/O Input Voltage	V_{IN}	-0.3	6.5	V
7	Analog Reference	V_{RH}, V_{RL}	-0.3	6.5	V
8	XFC, EXTAL, XTAL inputs	V_{ILV}	-0.3	3.0	V
9	TEST input	V_{TEST}	-0.3	10.0	V
10	Instantaneous Maximum Current Single pin limit for all digital I/O pins ²	I_D	-25	+25	mA
11	Instantaneous Maximum Current Single pin limit for XFC, EXTAL, XTAL ³	I_{DL}	-25	+25	mA
12	Instantaneous Maximum Current Single pin limit for TEST ⁴	I_{DT}	-0.25	0	mA
13	Operating Temperature Range (packaged)	T_A	-40	125	°C
14	Operating Temperature Range (junction)	T_J	-40	140	°C
15	Storage Temperature Range	T_{stg}	-65	155	°C

¹ The device contains an internal voltage regulator to generate the logic and PLL supply out of the I/O supply. The absolute maximum ratings apply when the device is powered from an external source.

² All digital I/O pins are internally clamped to V_{SSX} and V_{DDX} , V_{SSR} and V_{DDR} or V_{SSA} and V_{DDA} .

³ These pins are internally clamped to V_{SSPLL} and V_{DDPLL} .

⁴ This pin is clamped low to V_{SSR} , but not clamped high. This pin must be tied low in applications.

A.1.6 ESD Protection and Latch-up Immunity

All ESD testing is in conformity with CDF-AEC-Q100 Stress test qualification for Automotive Grade Integrated Circuits. During the device qualification ESD stresses were performed for the Human Body Model (HBM), the Machine Model (MM) and the Charge Device Model.

A device will be defined as a failure if after exposure to ESD pulses the device no longer meets the device specification. Complete DC parametric and functional testing is performed per the applicable device specification at room temperature followed by hot temperature, unless specified otherwise in the device specification.

Table A-2. ESD and Latch-up Test Conditions

Model	Description	Symbol	Value	Unit
Human Body	Series Resistance	R1	1500	Ohm
	Storage Capacitance	C	100	pF
	Number of Pulse per pin positive negative	— —	3 3	
Machine	Series Resistance	R1	0	Ohm
	Storage Capacitance	C	200	pF
	Number of Pulse per pin positive negative	— —	3 3	
Latch-up	Minimum input voltage limit	—	-2.5	V
	Maximum input voltage limit	—	7.5	V

Table A-3. ESD and Latch-Up Protection Characteristics

Num	C	Rating	Symbol	Min	Max	Unit
1	C	Human Body Model (HBM)	V_{HBM}	2000	—	V
2	C	Machine Model (MM)	V_{MM}	200	—	V
3	C	Charge Device Model (CDM)	V_{CDM}	500	—	V
4	C	Latch-up Current at 125°C positive negative	I_{LAT}	+100 -100	— —	mA
5	C	Latch-up Current at 27°C positive negative	I_{LAT}	+200 -200	— —	mA

A.1.7 Operating Conditions

This chapter describes the operating conditions of the device. Unless otherwise noted those conditions apply to all the following data.

NOTE

Instead of specifying ambient temperature all parameters are specified for the more meaningful silicon junction temperature. For power dissipation calculations refer to [Section A.1.8, “Power Dissipation and Thermal Characteristics”](#).

Table A-4. Operating Conditions

Rating	Symbol	Min	Typ	Max	Unit
I/O, Regulator and Analog Supply Voltage	V_{DD5}	2.97	3.3/5	5.5	V
Internal Logic Supply Voltage ¹	V_{DD}	2.35	2.5	2.75	V
PLL Supply Voltage ¹	V_{DDPLL}	2.35	2.5	2.75	V
Voltage Difference VDDX to VDDA	ΔV_{DDX}	-0.1	0	0.1	V
Voltage Difference VSSX to VSSR and VSSA	ΔV_{SSX}	-0.1	0	0.1	V
Oscillator	f_{osc}	0.5	—	16	MHz
Bus Frequency ²	f_{bus}	0.25	—	25	MHz
Operating Junction Temperature Range	T_J	-40	—	140	°C

¹ The device contains an internal voltage regulator to generate the logic and PLL supply out of the I/O supply. The given operating range applies when this regulator is disabled and the device is powered from an external source.

² Some blocks e.g. ATD (conversion) and NVMs (program/erase) require higher bus frequencies for proper operation.

A.1.8 Power Dissipation and Thermal Characteristics

Power dissipation and thermal characteristics are closely related. The user must assure that the maximum operating junction temperature is not exceeded. The average chip-junction temperature (T_J) in °C can be obtained from:

$$T_J = T_A + (P_D \cdot \Theta_{JA})$$

T_J = Junction Temperature, [°C]

T_A = Ambient Temperature, [°C]

P_D = Total Chip Power Dissipation, [W]

Θ_{JA} = Package Thermal Resistance, [°C/W]

The total power dissipation can be calculated from:

$$P_D = P_{INT} + P_{IO}$$

P_{INT} = Chip Internal Power Dissipation, [W]

Two cases with internal voltage regulator enabled and disabled must be considered:

1. Internal Voltage Regulator disabled

$$P_{INT} = I_{DD} \cdot V_{DD} + I_{DDPLL} \cdot V_{DDPLL} + I_{DDA} \cdot V_{DDA}$$

$$P_{IO} = \sum_i R_{DSON} \cdot I_{IO_i}^2$$

Which is the sum of all output currents on I/O ports associated with VDDX and VDDM.

For R_{DSON} is valid:

$$R_{DSON} = \frac{V_{OL}}{I_{OL}}; \text{for outputs driven low}$$

respectively

$$R_{DSON} = \frac{V_{DD5} - V_{OH}}{I_{OH}}; \text{for outputs driven high}$$

2. Internal voltage regulator enabled

$$P_{INT} = I_{DDR} \cdot V_{DDR} + I_{DDA} \cdot V_{DDA}$$

I_{DDR} is the current shown in [Table A-8](#) and not the overall current flowing into VDDR, which additionally contains the current flowing into the external loads with output high.

$$P_{IO} = \sum_i R_{DSON} \cdot I_{IO_i}^2$$

Which is the sum of all output currents on I/O ports associated with VDDX and VDDR.

Table A-5. Thermal Package Characteristics¹

Num	C	Rating	Symbol	Min	Typ	Max	Unit
1	T	Thermal Resistance LQFP112, single sided PCB ²	θ_{JA}	—	—	54	°C/W
2	T	Thermal Resistance LQFP112, double sided PCB with 2 internal planes ³	θ_{JA}	—	—	41	°C/W
3	T	Junction to Board LQFP112	θ_{JB}	—	—	31	°C/W
4	T	Junction to Case LQFP112	θ_{JC}	—	—	11	°C/W
5	T	Junction to Package Top LQFP112	Ψ_{JT}	—	—	2	°C/W
6	T	Thermal Resistance QFP 80, single sided PCB	θ_{JA}	—	—	51	°C/W
7	T	Thermal Resistance QFP 80, double sided PCB with 2 internal planes	θ_{JA}	—	—	41	°C/W
8	T	Junction to Board QFP80	θ_{JB}	—	—	27	°C/W
9	T	Junction to Case QFP80	θ_{JC}	—	—	14	°C/W
10	T	Junction to Package Top QFP80	Ψ_{JT}	—	—	3	°C/W

¹ The values for thermal resistance are achieved by package simulations

² PC Board according to EIA/JEDEC Standard 51-3

³ PC Board according to EIA/JEDEC Standard 51-7

A.1.9 I/O Characteristics

This section describes the characteristics of all 3.3V/5V I/O pins. All parameters are not always applicable, e.g., not all pins feature pull up/down resistances.

Table A-6. 5V I/O Characteristics

Conditions are shown in Table A-4 unless otherwise noted							
Num	C	Rating	Symbol	Min	Typ	Max	Unit
1	P	Input High Voltage	V_{IH}	$0.65 \cdot V_{DD5}$	—	—	V
	T	Input High Voltage	V_{IH}	—	—	$V_{DD5} + 0.3$	V
2	P	Input Low Voltage	V_{IL}	—	—	$0.35 \cdot V_{DD5}$	V
	T	Input Low Voltage	V_{IL}	$V_{SS5} - 0.3$	—	—	V
3	C	Input Hysteresis	V_{HYS}	—	250	—	mV
4	P	Input Leakage Current (pins in high ohmic input mode) ¹ $V_{in} = V_{DD5}$ or V_{SS5}	I_{in}	-1.0	—	1.0	∞ A
5	C	Output High Voltage (pins in output mode) Partial Drive $I_{OH} = -2$ mA	V_{OH}	$V_{DD5} - 0.8$	—	—	V
6	P	Output High Voltage (pins in output mode) Full Drive $I_{OH} = -10$ mA	V_{OH}	$V_{DD5} - 0.8$	—	—	V
7	C	Output Low Voltage (pins in output mode) Partial Drive $I_{OL} = +2$ mA	V_{OL}	—	—	0.8	V
8	P	Output Low Voltage (pins in output mode) Full Drive $I_{OL} = +10$ mA	V_{OL}	—	—	0.8	V
9	P	Internal Pull Up Device Current, tested at V_{IL} Max.	I_{PUL}	—	—	-130	∞ A
10	C	Internal Pull Up Device Current, tested at V_{IH} Min.	I_{PUH}	-10	—	—	∞ A
11	P	Internal Pull Down Device Current, tested at V_{IH} Min.	I_{PDH}	—	—	130	∞ A
12	C	Internal Pull Down Device Current, tested at V_{IL} Max.	I_{PDL}	10	—	—	∞ A
13	D	Input Capacitance	C_{in}	—	6	—	pF
14	T	Injection current ²					
		Single Pin limit	I_{ICS}	-2.5	—	2.5	mA
Total Device Limit. Sum of all injected currents	I_{ICP}	-25	—	25			
15	P	Port AD Interrupt Input Pulse filtered ³	t_{PIGN}	—	—	3	∞ s
16	P	Port AD Interrupt Input Pulse passed ³	t_{PVAL}	10	—	—	∞ s

¹ Maximum leakage current occurs at maximum operating temperature. Current decreases by approximately one-half for each 8 C to 12 C in the temperature range from 50 C to 125 C

² Refer to [Section A.1.4, “Current Injection”](#) for more details

³ Parameter only applies in STOP or Pseudo STOP mode.

Table A-7. Preliminary 3.3V I/O Characteristics

Conditions are shown in Table A-4 unless otherwise noted							
Num	C	Rating	Symbol	Min	Typ	Max	Unit
1	P	Input High Voltage	V_{IH}	$0.65 \cdot V_{DD5}$	—	—	V
	T	Input High Voltage	V_{IH}	—	—	$V_{DD5} + 0.3$	V
2	P	Input Low Voltage	V_{IL}	—	—	$0.35 \cdot V_{DD5}$	V
	T	Input Low Voltage	V_{IL}	$V_{SS5} - 0.3$	—	—	V
3	C	Input Hysteresis	V_{HYS}		250		mV
4	P	Input Leakage Current (pins in high ohmic input mode) ¹ $V_{in} = V_{DD5}$ or V_{SS5}	I_{in}	-1.0	—	1.0	∞ A
5	C	Output High Voltage (pins in output mode) Partial Drive $I_{OH} = -0.75$ mA	V_{OH}	$V_{DD5} - 0.4$	—	—	V
6	P	Output High Voltage (pins in output mode) Full Drive $I_{OH} = -4$ mA	V_{OH}	$V_{DD5} - 0.4$	—	—	V
7	C	Output Low Voltage (pins in output mode) Partial Drive $I_{OL} = +0.9$ mA	V_{OL}	—	—	0.4	V
8	P	Output Low Voltage (pins in output mode) Full Drive $I_{OL} = +4.75$ mA	V_{OL}	—	—	0.4	V
9	P	Internal Pull Up Device Current, tested at V_{IL} Max.	I_{PUL}	—	—	-60	∞ A
10	C	Internal Pull Up Device Current, tested at V_{IH} Min.	I_{PUH}	-6	—	—	∞ A
11	P	Internal Pull Down Device Current, tested at V_{IH} Min.	I_{PDH}	—	—	60	∞ A
12	C	Internal Pull Down Device Current, tested at V_{IL} Max.	I_{PDL}	6	—	—	∞ A
13	D	Input Capacitance	C_{in}	—	6	—	pF
14	T	Injection current ² Single Pin limit	I_{ICS}	-2.5	—	2.5	mA
		Total Device Limit. Sum of all injected currents	I_{ICP}	-25	—	25	
15	P	Port AD Interrupt Input Pulse filtered ³	t_{PIGN}	—	—	3	∞ s
16	P	Port AD Interrupt Input Pulse passed ³	t_{PVAL}	10	—	—	∞ s

¹ Maximum leakage current occurs at maximum operating temperature. Current decreases by approximately one-half for each 8 C to 12 C in the temperature range from 50 C to 125 C

² Refer to Section A.1.4, “Current Injection”, for more details

³ Parameter only applies in STOP or Pseudo STOP mode.

A.1.10 Supply Currents

This section describes the current consumption characteristics of the device as well as the conditions for the measurements.

A.1.10.1 Measurement Conditions

All measurements are without output loads. Unless otherwise noted the currents are measured in single chip mode, internal voltage regulator enabled and at 25MHz bus frequency using a 4MHz oscillator.

A.1.10.2 Additional Remarks

In expanded modes the currents flowing in the system are highly dependent on the load at the address, data and control signals as well as on the duty cycle of those signals. No generally applicable numbers can be given. A very good estimate is to take the single chip currents and add the currents due to the external loads.

Table A-8. Supply Current Characteristics

Conditions are shown in Table A-4 unless otherwise noted							
Num	C	Rating	Symbol	Min	Typ	Max	Unit
1	P	Run supply currents Single Chip, Internal regulator enabled	I_{DD5}	—	—	65	mA
2	P	Wait Supply current All modules enabled only RTI enabled	I_{DDW}	—	—	40	mA
	P			—	—	5	
3	C C C C C C C	Pseudo Stop Current (RTI and COP enabled) ^{1, 2} -40°C 27°C 70°C 85°C 105°C 125°C 140°C	I_{DDPS}	—	570	—	∞A
				—	600	—	
				—	650	—	
				—	750	—	
				—	850	—	
				—	1200	—	
				—	1500	—	
4	C P C C P C P C P	Pseudo Stop Current (RTI and COP disabled) ^{1, 2} -40°C 27°C 70°C 85°C "C" Temp Option 100°C 105°C "V" Temp Option 120°C 125°C "M" Temp Option 140°C	I_{DDPS}	—	370	—	∞A
				—	400	500	
				—	450	—	
				—	550	—	
				—	600	1600	
				—	650	—	
				—	800	2100	
				—	850	—	
				—	1200	5000	
				—	1200	5000	
5	C P C C P C P C P	Stop Current ² -40°C 27°C 70°C 85°C "C" Temp Option 100°C 105°C "V" Temp Option 120°C 125°C "M" Temp Option 140°C	I_{DD5}	—	12	—	∞A
				—	30	100	
				—	100	—	
				—	130	—	
				—	160	1200	
				—	200	—	
				—	350	1700	
				—	400	—	
				—	600	5000	
				—	600	5000	

¹ PLL off

² At those low power dissipation levels $T_J = T_A$ can be assumed

A.2 Voltage Regulator

This section describes the characteristics of the on chip voltage regulator.

Table A-9. Voltage Regulator Electrical Parameters

Num	C	Characteristic	Symbol	Min	Typ	Max	Unit
1	P	Input Voltages	$V_{VDDR,A}$	2.97	—	5.5	V
3	P	Output Voltage Core Full Performance Mode	V_{DD}	2.35	2.5	2.75	V
4	P	Output Voltage PLL Full Performance Mode	V_{DDPLL}	2.35	2.5	2.75	V
5	P	Low Voltage Interrupt ¹ Assert Level Deassert Level	V_{LVIA} V_{LVID}	4.0 4.15	4.37 4.52	4.66 4.77	V V
6	P	Low Voltage Reset ² Assert Level Deassert Level	V_{LVRA} V_{LVRD}	2.25 —	— —	— 2.55	V V
7	C	Power-on Reset ³ Assert Level Deassert Level	V_{PORA} V_{PORD}	0.97 —	— —	— 2.05	V V

¹ Monitors V_{DDA} , active only in Full Performance Mode. Indicates I/O & ADC performance degradation due to low supply voltage.

² Monitors V_{DD} , active only in Full Performance Mode. V_{LVRA} and V_{PORD} must overlap

³ Monitors V_{DD} . Active in all modes.

A.2.1 Chip Power-up and LVI/LVR Graphical Explanation

Voltage regulator sub modules LVI (low voltage interrupt), POR (power-on reset) and LVR (low voltage reset) handle chip power-up or drops of the supply voltage. Their function is described in [Figure A-1](#).

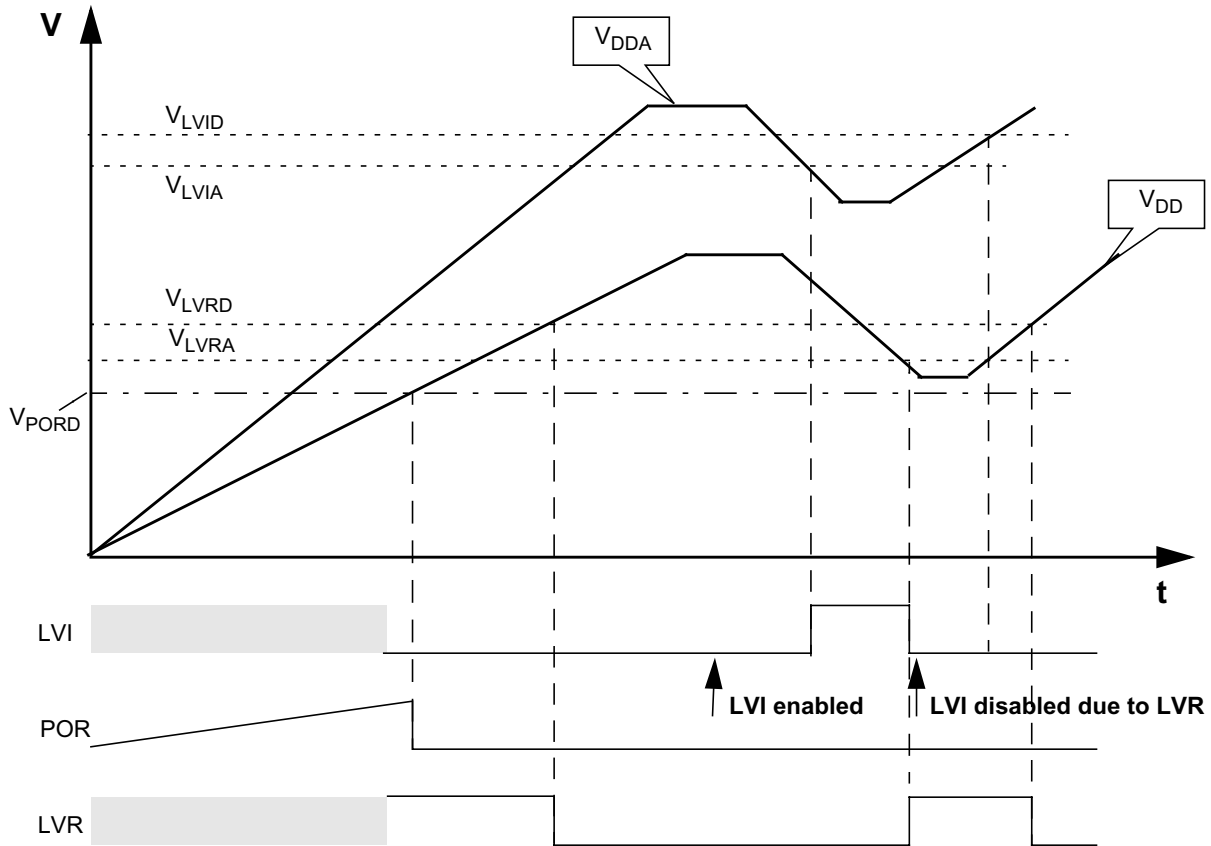

Figure A-1. Voltage Regulator — Chip Power-up and Voltage Drops (not scaled)

A.2.2 Output Loads

A.2.2.1 Resistive Loads

The on-chip voltage regulator is intended to supply the internal logic and oscillator circuits allows no external DC loads.

A.2.2.2 Capacitive Loads

The capacitive loads are specified in [Table A-10](#). Ceramic capacitors with X7R dielectricum are required.

Table A-10. Voltage Regulator — Capacitive Loads

Num	Characteristic	Symbol	Min	Typ	Max	Unit
1	V_{DD} external capacitive load	C_{DDext}	200	440	12000	nF
2	V_{DDPLL} external capacitive load	$C_{DDPLLext}$	90	220	5000	nF

A.3 Startup, Oscillator, and PLL

A.3.1 Startup

[Table A-11](#) summarizes several startup characteristics explained in this section.

Table A-11. Startup Characteristics

Conditions are shown in Table A-4 unless otherwise noted							
Num	C	Rating	Symbol	Min	Typ	Max	Unit
1	T	POR release level	V_{PORR}	—	—	2.07	V
2	T	POR assert level	V_{PORA}	0.97	—	—	V
3	D	Reset input pulse width, minimum input time	PW_{RSTL}	2	—	—	t_{osc}
4	D	Startup from Reset	n_{RST}	192	—	196	n_{osc}
5	D	Interrupt pulse width, \overline{IRQ} edge-sensitive mode	PW_{IRQ}	20	—	—	ns
6	D	Wait recovery startup time	t_{WRS}	—	—	14	t_{cyc}
7	P	LVR release level	V_{LVRR}	2.25	—	—	V
8	P	LVR assert level	V_{LVRA}	—	—	2.55	V

A.3.1.1 POR

The release level V_{PORR} and the assert level V_{PORA} are derived from the V_{DD} Supply. They are also valid if the device is powered externally. After releasing the POR reset the oscillator and the clock quality check are started. If after a time t_{CQOUT} no valid oscillation is detected, the MCU will start using the internal self clock. The fastest startup time possible is given by n_{uposc} .

A.3.1.2 LVR

The release level V_{LVRR} and the assert level V_{LVRA} are derived from the V_{DD} Supply. They are also valid if the device is powered externally. After releasing the LVR reset the oscillator and the clock quality check are started. If after a time t_{CQOUT} no valid oscillation is detected, the MCU will start using the internal self clock. The fastest startup time possible is given by n_{uposc} .

A.3.1.3 SRAM Data Retention

Provided an appropriate external reset signal is applied to the MCU, preventing the CPU from executing code when V_{DD5} is out of specification limits, the SRAM contents integrity is guaranteed if after the reset the PORF bit in the CRG Flags Register has not been set.

A.3.1.4 External Reset

When external reset is asserted for a time greater than PW_{RSTL} the CRG module generates an internal reset, and the CPU starts fetching the reset vector without doing a clock quality check, if there was an oscillation before reset.

A.3.1.5 Stop Recovery

Out of STOP the controller can be woken up by an external interrupt. A clock quality check as after POR is performed before releasing the clocks to the system.

A.3.1.6 Pseudo Stop and Wait Recovery

The recovery from Pseudo STOP and Wait are essentially the same since the oscillator was not stopped in both modes. The controller can be woken up by internal or external interrupts. After t_{wrs} the CPU starts fetching the interrupt vector.

A.3.2 Oscillator

The device features an internal Colpitts and Pierce oscillator. The selection of Colpitts oscillator or Pierce oscillator/external clock depends on the \overline{XCLKS} signal which is sampled during reset. Pierce oscillator/external clock mode allows the input of a square wave. Before asserting the oscillator to the internal system clocks the quality of the oscillation is checked for each start from either power-on, STOP or oscillator fail. t_{CQOUT} specifies the maximum time before switching to the internal self clock mode after POR or STOP if a proper oscillation is not detected. The quality check also determines the minimum oscillator start-up time t_{UPOSC} . The device also features a clock monitor. A Clock Monitor Failure is asserted if the frequency of the incoming clock signal is below the Assert Frequency f_{CMFA} .

Table A-12. Oscillator Characteristics

Conditions are shown in Table A-4 unless otherwise noted							
Num	C	Rating	Symbol	Min	Typ	Max	Unit
1a	C	Crystal oscillator range (Colpitts)	f_{OSC}	0.5	—	16	MHz
1b	C	Crystal oscillator range (Pierce) ¹	f_{OSC}	0.5	—	40	MHz
2	P	Startup Current	i_{OSC}	100	—	—	∞ A
3	C	Oscillator start-up time (Colpitts)	t_{UPOSC}	—	8 ²	100 ³	ms
4	D	Clock Quality check time-out	t_{CQOUT}	0.45	—	2.5	s
5	P	Clock Monitor Failure Assert Frequency	f_{CMFA}	50	100	200	KHz
6	P	External square wave input frequency ⁴	f_{EXT}	0.5	—	50	MHz
7	D	External square wave pulse width low ⁴	t_{EXTL}	9.5	—	—	ns
8	D	External square wave pulse width high ⁴	t_{EXTH}	9.5	—	—	ns
9	D	External square wave rise time ⁴	t_{EXTR}	—	—	1	ns
10	D	External square wave fall time ⁴	t_{EXTF}	—	—	1	ns
11	D	Input Capacitance (EXTAL, XTAL pins)	C_{IN}	—	7	—	pF
12	C	DC Operating Bias in Colpitts Configuration on EXTAL Pin	V_{DCBIAS}	—	1.1	—	V
13	P	EXTAL Pin Input High Voltage ⁴	$V_{IH,EXTAL}$	$0.75 \cdot V_{DDPLL}$	—	—	V
	T	EXTAL Pin Input High Voltage ⁴	$V_{IH,EXTAL}$	—	—	$V_{DDPLL} + 0.3$	V
14	P	EXTAL Pin Input Low Voltage ⁴	$V_{IL,EXTAL}$	—	—	$0.25 \cdot V_{DDPLL}$	V
	T	EXTAL Pin Input Low Voltage ⁴	$V_{IL,EXTAL}$	$V_{SSPLL} - 0.3$	—	—	V
15	C	EXTAL Pin Input Hysteresis ⁴	$V_{HYS,EXTAL}$	—	250	—	mV

¹ Depending on the crystal a damping series resistor might be necessary

² $f_{osc} = 4\text{MHz}$, $C = 22\text{pF}$.

³ Maximum value is for extreme cases using high Q, low frequency crystals

⁴ Only valid if Pierce oscillator/external clock mode is selected

A.3.3 Phase Locked Loop

The oscillator provides the reference clock for the PLL. The PLL's Voltage Controlled Oscillator (VCO) is also the system clock source in self clock mode.

A.3.3.1 XFC Component Selection

This section describes the selection of the XFC components to achieve a good filter characteristics.

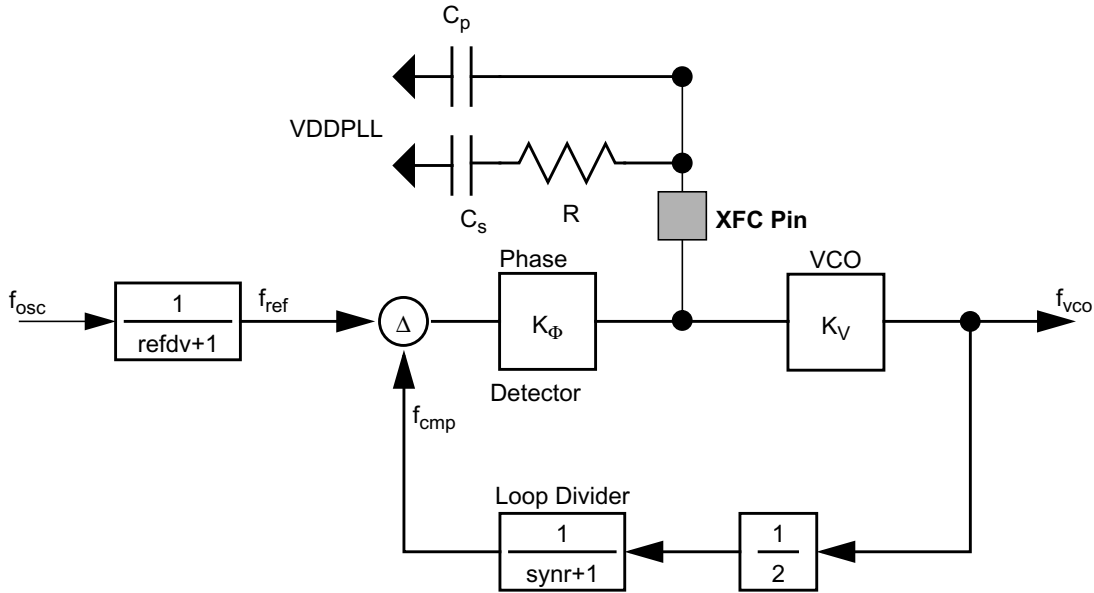

Figure A-2. Basic PLL Functional Diagram

The following procedure can be used to calculate the resistance and capacitance values using typical values for K_1 , f_1 and i_{ch} from [Table A-13](#).

The grey boxes show the calculation for $f_{VCO} = 50\text{MHz}$ and $f_{ref} = 1\text{MHz}$. E.g., these frequencies are used for $f_{OSC} = 4\text{MHz}$ and a 25MHz bus clock.

The VCO Gain at the desired VCO frequency is approximated by:

$$K_V = K_1 \cdot e^{\frac{(f_1 - f_{VCO})}{K_1 \cdot 1V}} = -100 \cdot e^{\frac{(60 - 50)}{-100}} = -90.48\text{MHz/V}$$

The phase detector relationship is given by:

$$K_\Phi = -|i_{ch}| \cdot K_V = 316.7\text{Hz}/\Omega$$

i_{ch} is the current in tracking mode.

The loop bandwidth f_C should be chosen to fulfill the Gardner's stability criteria by at least a factor of 10, typical values are 50. $\zeta = 0.9$ ensures a good transient response.

$$f_C < \frac{2 \cdot \zeta \cdot f_{\text{ref}}}{\pi \cdot (\zeta + \sqrt{1 + \zeta^2})} \cdot \frac{1}{10} \rightarrow f_C < \frac{f_{\text{ref}}}{4 \cdot 10}; (\zeta = 0.9)$$

$$f_C < 25\text{kHz}$$

And finally the frequency relationship is defined as

$$n = \frac{f_{\text{VCO}}}{f_{\text{ref}}} = 2 \cdot (\text{synr} + 1) = 50$$

With the above values the resistance can be calculated. The example is shown for a loop bandwidth $f_C=10\text{kHz}$:

$$R = \frac{2 \cdot \pi \cdot n \cdot f_C}{K_\Phi} = 2 \cdot \pi \cdot 50 \cdot 10\text{kHz} / (316.7\text{Hz}/\Omega) = 9.9\text{k}\Omega \approx 10\text{k}\Omega$$

The capacitance C_s can now be calculated as:

$$C_s = \frac{2 \cdot \zeta^2}{\pi \cdot f_C \cdot R} \approx \frac{0.516}{f_C \cdot R}; (\zeta = 0.9) = 5.19\text{nF} \approx 4.7\text{nF}$$

The capacitance C_p should be chosen in the range of:

$$C_s/20 \leq C_p \leq C_s/10 \quad C_p = 470\text{pF}$$

A.3.3.2 Jitter Information

The basic functionality of the PLL is shown in [Figure A-2](#). With each transition of the clock f_{cmp} , the deviation from the reference clock f_{ref} is measured and input voltage to the VCO is adjusted accordingly. The adjustment is done continuously with no abrupt changes in the clock output frequency. Noise, voltage, temperature and other factors cause slight variations in the control loop resulting in a clock jitter. This jitter affects the real minimum and maximum clock periods as illustrated in [Figure A-3](#).

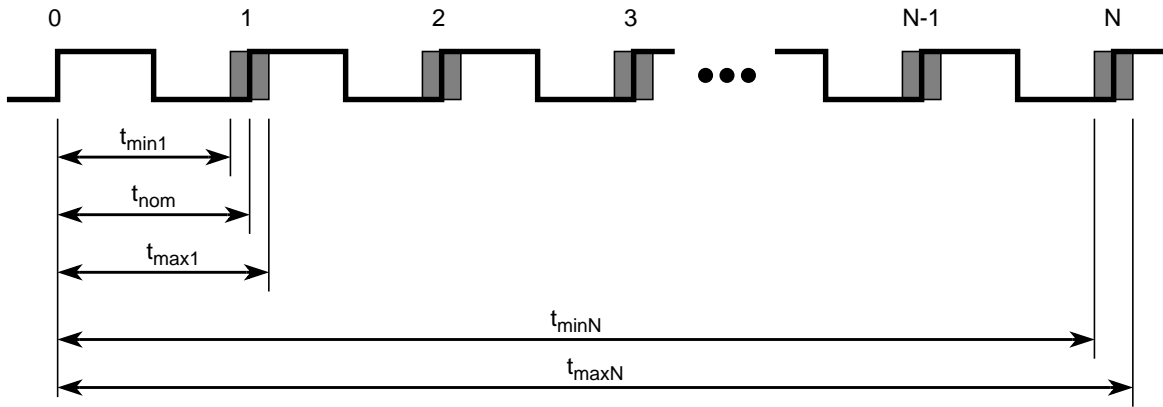

Figure A-3. Jitter Definitions

The relative deviation of t_{nom} is at its maximum for one clock period, and decreases towards zero for larger number of clock periods (N).

Defining the jitter as:

$$J(N) = \max\left(\left|1 - \frac{t_{max}(N)}{N \cdot t_{nom}}\right|, \left|1 - \frac{t_{min}(N)}{N \cdot t_{nom}}\right|\right)$$

For $N < 100$, the following equation is a good fit for the maximum jitter:

$$J(N) = \frac{j_1}{\sqrt{N}} + j_2$$

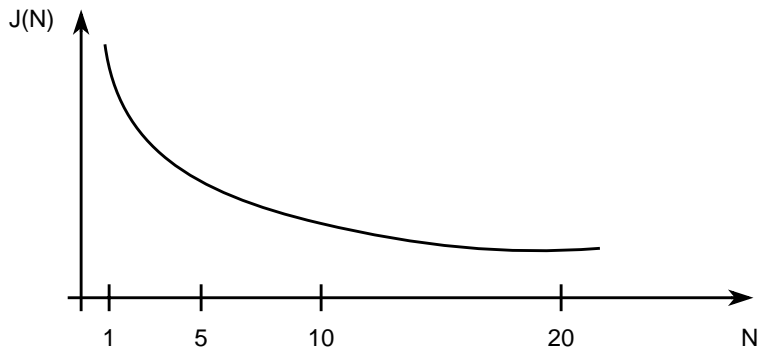

This is very important to notice with respect to timers, serial modules where a prescaler will eliminate the effect of the jitter to a large extent.

Table A-13. PLL Characteristics

Conditions are shown in Table A-4 unless otherwise noted

Num	C	Rating	Symbol	Min	Typ	Max	Unit
1	P	Self Clock Mode frequency	f_{SCM}	1	—	5.5	MHz
2	D	VCO locking range	f_{VCO}	8	—	50	MHz
3	D	Lock Detector transition from Acquisition to Tracking mode	$ \Delta_{trk} $	3	—	4	% ¹
4	D	Lock Detection	$ \Delta_{Lock} $	0	—	1.5	% ¹
5	D	Un-Lock Detection	$ \Delta_{unl} $	0.5	—	2.5	% ¹
6	D	Lock Detector transition from Tracking to Acquisition mode	$ \Delta_{unt} $	6	—	8	% ¹
7	C	PLLON Total Stabilization delay (Auto Mode) ²	t_{stab}	—	0.5	—	ms
8	D	PLLON Acquisition mode stabilization delay ²	t_{acq}	—	0.3	—	ms
9	D	PLLON Tracking mode stabilization delay ²	t_{al}	—	0.2	—	ms
10	D	Fitting parameter VCO loop gain	K_1	—	-100	—	MHz/V
11	D	Fitting parameter VCO loop frequency	f_1	—	60	—	MHz
12	D	Charge pump current acquisition mode	$ i_{ch} $	—	38.5	—	∞ A
13	D	Charge pump current tracking mode	$ i_{ch} $	—	3.5	—	∞ A
14	C	Jitter fit parameter 1 ²	j_1	—	—	1.1	%
15	C	Jitter fit parameter 2 ²	j_2	—	—	0.13	%

¹ % deviation from target frequency

² $f_{OSC} = 4\text{MHz}$, $f_{BUS} = 25\text{MHz}$ equivalent $f_{VCO} = 50\text{MHz}$: REFDV = #03, SYNR = #018, Cs = 4.7nF, Cp = 470pF, Rs = 10K Ω .

A.4 Flash NVM

A.4.1 NVM Timing

The time base for all NVM program or erase operations is derived from the oscillator. A minimum oscillator frequency f_{NVMOSC} is required for performing program or erase operations. The NVM modules do not have any means to monitor the frequency and will not prevent program or erase operation at frequencies above or below the specified minimum. Attempting to program or erase the NVM modules at a lower frequency a full program or erase transition is not assured.

The Flash program and erase operations are timed using a clock derived from the oscillator using the FCLKDIV register. The frequency of this clock must be set within the limits specified as f_{NVMOP} .

The minimum program and erase times shown in [Table A-14](#) are calculated for maximum f_{NVMOP} and maximum f_{bus} . The maximum times are calculated for minimum f_{NVMOP} and a f_{bus} of 2MHz.

A.4.1.1 Single Word Programming

The programming time for single word programming is dependent on the bus frequency as well as on the frequency f_{NVMOP} and can be calculated according to the following formula.

$$t_{\text{swpgm}} = 9 \cdot \frac{1}{f_{\text{NVMOP}}} + 25 \cdot \frac{1}{f_{\text{bus}}}$$

A.4.1.2 Row Programming

Flash programming where up to 64 words in a row can be programmed consecutively by keeping the command pipeline filled. The time to program a consecutive word can be calculated as:

$$t_{\text{bwpgm}} = 4 \cdot \frac{1}{f_{\text{NVMOP}}} + 9 \cdot \frac{1}{f_{\text{bus}}}$$

The time to program a whole row is:

$$t_{\text{brpgm}} = t_{\text{swpgm}} + 63 \cdot t_{\text{bwpgm}}$$

Row programming is more than 2 times faster than single word programming.

A.4.1.3 Sector Erase

Erasing a 1024 byte Flash sector takes:

$$t_{\text{era}} \approx 4000 \cdot \frac{1}{f_{\text{NVMOP}}}$$

The setup times can be ignored for this operation.

A.4.1.4 Mass Erase

Erasing a NVM block takes:

$$t_{\text{mass}} \approx 20000 \cdot \frac{1}{f_{\text{NVMOP}}}$$

The setup times can be ignored for this operation.

A.4.1.5 Blank Check

The time it takes to perform a blank check on the Flash is dependant on the location of the first non-blank word starting at relative address zero. It takes one bus cycle per word to verify plus a setup of the command.

$$t_{\text{check}} \approx \text{location} \cdot t_{\text{cyc}} + 10 \cdot t_{\text{cyc}}$$

Table A-14. NVM Timing Characteristics

Conditions are shown in Table A-4 unless otherwise noted							
Num	C	Rating	Symbol	Min	Typ	Max	Unit
1	D	External Oscillator Clock	f_{NVMOSC}	0.5	—	50 ¹	MHz
2	D	Bus frequency for Programming or Erase Operations	f_{NVMBUS}	1	—	—	MHz
3	D	Operating Frequency	f_{NVMOP}	150	—	200	kHz
4	P	Single Word Programming Time	t_{swpgm}	46 ²	—	74.5 ³	∞s
5	D	Flash Burst Programming consecutive word	t_{bwpgm}	20.4 ²	—	31 ³	∞s
6	D	Flash Burst Programming Time for 64 Word row	t_{brpgm}	1331.2 ²	—	2027.5 ³	∞s
7	P	Sector Erase Time	t_{era}	20 ⁴	—	26.7 ³	ms
8	P	Mass Erase Time	t_{mass}	100 ⁴	—	133 ³	ms
9	D	Blank Check Time Flash per block	t_{check}	11 ⁵	—	65546 ⁶	⁷ t_{cyc}

¹ Restrictions for oscillator in crystal mode apply!

² Minimum Programming times are achieved under maximum NVM operating frequency f_{NVMOP} and maximum bus frequency f_{bus} .

³ Maximum Erase and Programming times are achieved under particular combinations of f_{NVMOP} and bus frequency f_{bus} . Refer to formulae in [Section A.4.1.1, "Single Word Programming"](#) through [Section A.4.1.4, "Mass Erase"](#) for guidance.

⁴ Minimum Erase times are achieved under maximum NVM operating frequency f_{NVMOP}

⁵ Minimum time, if first word in the array is not blank

⁶ Maximum time to complete check on an erased block

⁷ Where t_{cyc} is the system bus clock period.

A.4.2 NVM Reliability

The reliability of the NVM blocks is guaranteed by stress test during qualification, constant process monitors and burn-in to screen early life failures. The program/erase cycle count on the sector is incremented every time a sector or mass erase event is executed.

Table A-15. NVM Reliability Characteristics¹

Conditions are shown in Table A-4 unless otherwise noted							
Num	C	Rating	Symbol	Min	Typ	Max	Unit
Flash Reliability Characteristics							
1	C	Data retention after 10,000 program/erase cycles at an average junction temperature of $T_{Javg} \leq 85^{\circ}C$	t_{FLRET}	15	100^2	—	Years
2	C	Data retention with <100 program/erase cycles at an average junction temperature $T_{Javg} \leq 85^{\circ}C$		20	100^2	—	
3	C	Number of program/erase cycles ($-40^{\circ}C \leq T_J \leq 0^{\circ}C$)	n_{FL}	10,000	—	—	Cycles
4	C	Number of program/erase cycles ($0^{\circ}C \leq T_J \leq 140^{\circ}C$)		10,000	$100,000^3$	—	

- ¹ T_{Javg} will not exceed $85^{\circ}C$ considering a typical temperature profile over the lifetime of a consumer, industrial or automotive application.
- ² Typical data retention values are based on intrinsic capability of the technology measured at high temperature and de-rated to $25^{\circ}C$ using the Arrhenius equation. For additional information on how Freescale defines Typical Data Retention, please refer to Engineering Bulletin EB618.
- ³ Spec table quotes typical endurance evaluated at $25^{\circ}C$ for this product family, typical endurance at various temperature can be estimated using the graph below. For additional information on how Freescale defines Typical Endurance, please refer to Engineering Bulletin EB619.

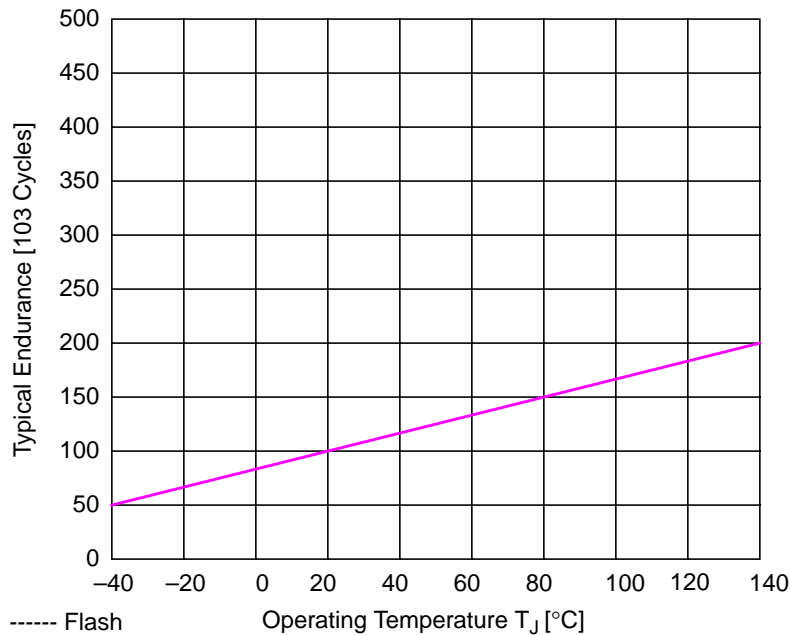

Figure A-4. Typical Endurance

A.5 SPI Characteristics

This section provides electrical parametrics and ratings for the SPI.

In [Table A-16](#) the measurement conditions are listed.

Table A-16. Measurement Conditions

Description	Value	Unit
Drive mode	full drive mode	—
Load capacitance C_{LOAD} , on all outputs	50	pF
Thresholds for delay measurement points	(20% / 80%) V_{DDX}	V

A.5.1 Master Mode

In [Figure A-5](#) the timing diagram for master mode with transmission format $CPHA=0$ is depicted.

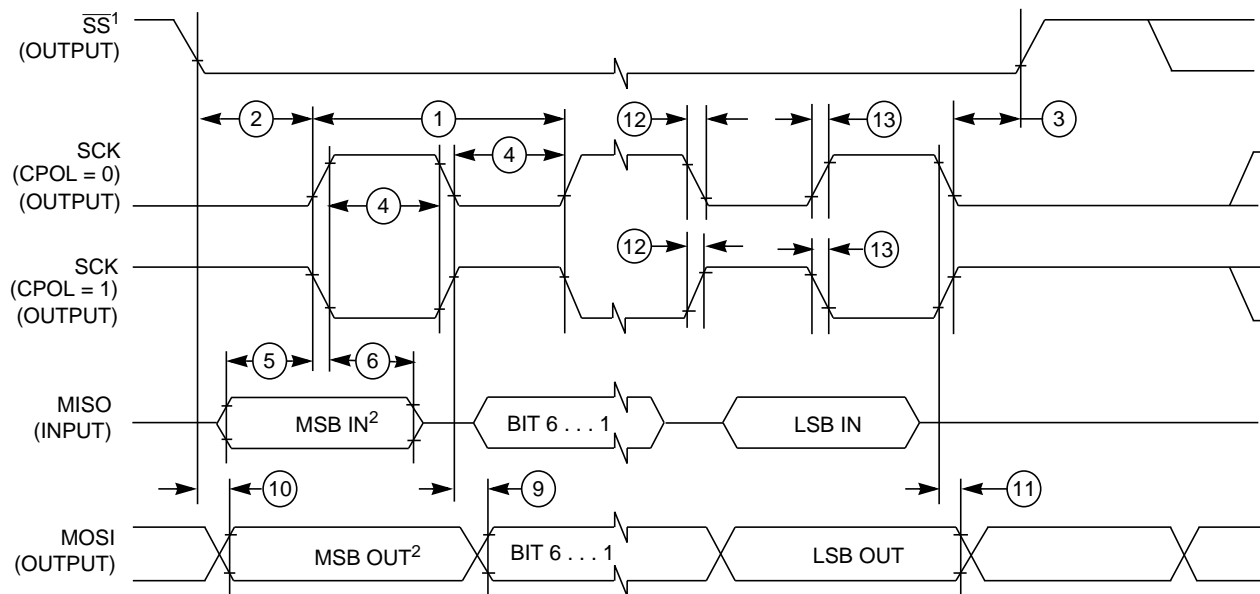

1. If configured as an output.

2. LSBF = 0. For LSBF = 1, bit order is LSB, bit 1, ..., bit 6, MSB.

Figure A-5. SPI Master Timing (CPHA = 0)

In [Figure A-6](#) the timing diagram for master mode with transmission format CPHA=1 is depicted.

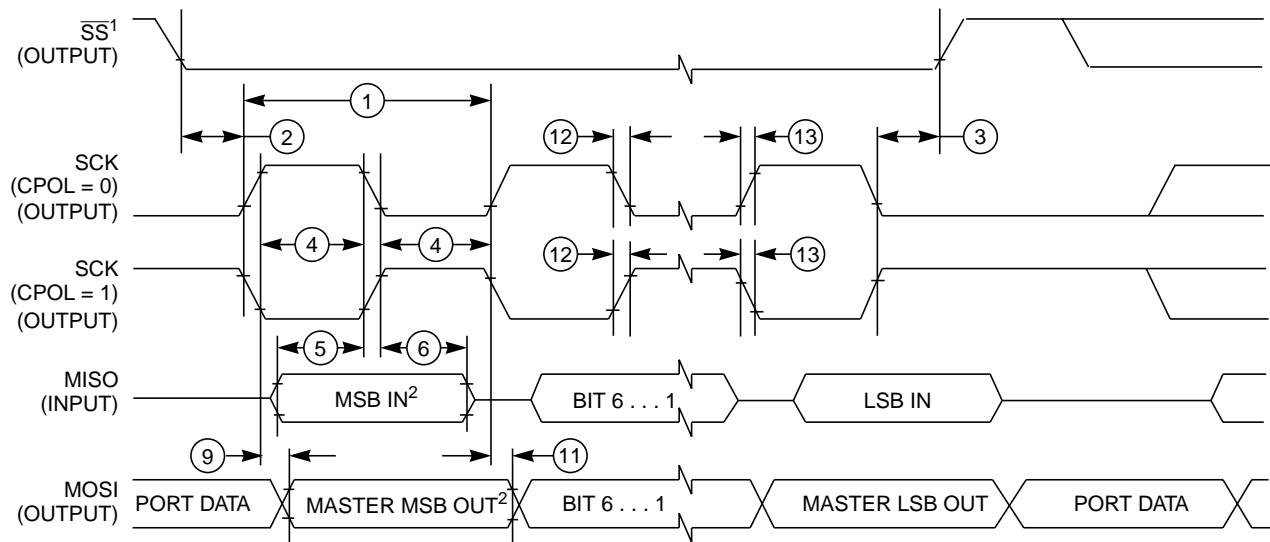

- 1. If configured as output
- 2. LSBF = 0. For LSBF = 1, bit order is LSB, bit 1, ..., bit 6, MSB.

Figure A-6. SPI Master Timing (CPHA=1)

In [Table A-17](#) the timing characteristics for master mode are listed.

Table A-17. SPI Master Mode Timing Characteristics

Num	C	Characteristic	Symbol	Min	Typ	Max	Unit
1	P	SCK Frequency	f_{sck}	1/2048	—	1/2	f_{bus}
1	P	SCK Period	t_{sck}	2	—	2048	t_{bus}
2	D	Enable Lead Time	t_{lead}	—	1/2	—	t_{sck}
3	D	Enable Lag Time	t_{lag}	—	1/2	—	t_{sck}
4	D	Clock (SCK) High or Low Time	t_{wsck}	—	1/2	—	t_{sck}
5	D	Data Setup Time (Inputs)	t_{su}	8	—	—	ns
6	D	Data Hold Time (Inputs)	t_{hi}	8	—	—	ns
9	D	Data Valid after SCK Edge	t_{vsck}	—	—	30	ns
10	D	Data Valid after \overline{SS} fall (CPHA = 0)	t_{vss}	—	—	15	ns
11	D	Data Hold Time (Outputs)	t_{ho}	20	—	—	ns
12	D	Rise and Fall Time Inputs	t_{rfi}	—	—	8	ns
13	D	Rise and Fall Time Outputs	t_{rfo}	—	—	8	ns

A.5.2 Slave Mode

In [Figure A-7](#) the timing diagram for slave mode with transmission format CPHA = 0 is depicted.

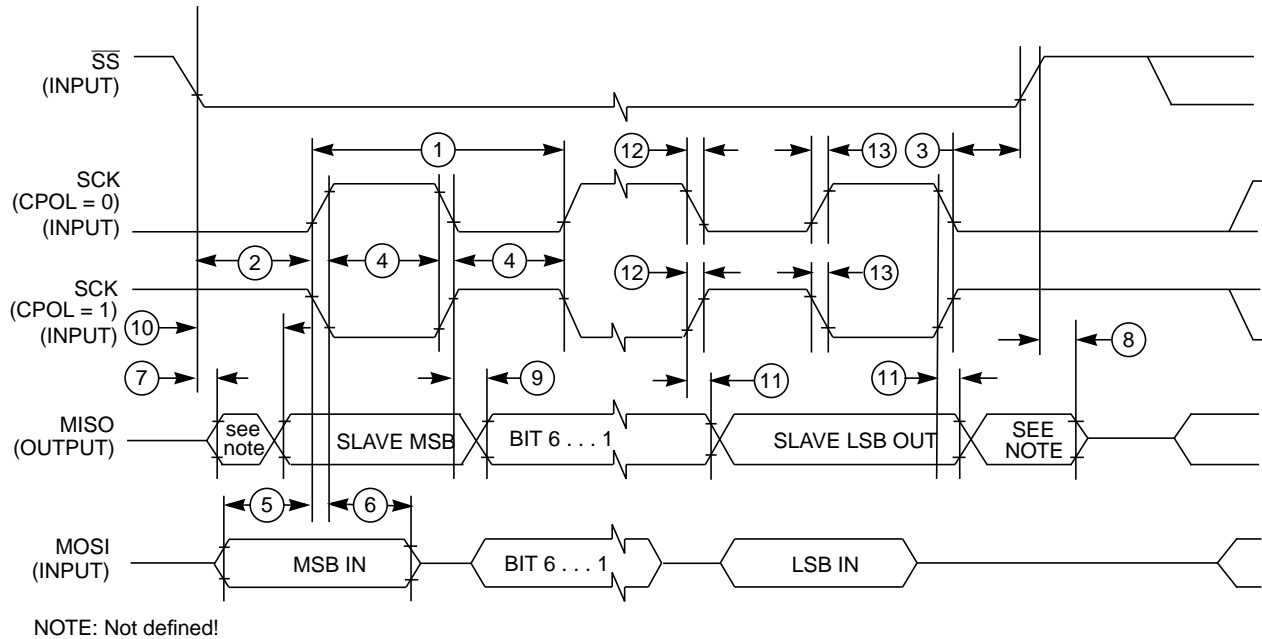

Figure A-7. SPI Slave Timing (CPHA = 0)

In [Figure A-8](#) the timing diagram for slave mode with transmission format CPHA = 1 is depicted.

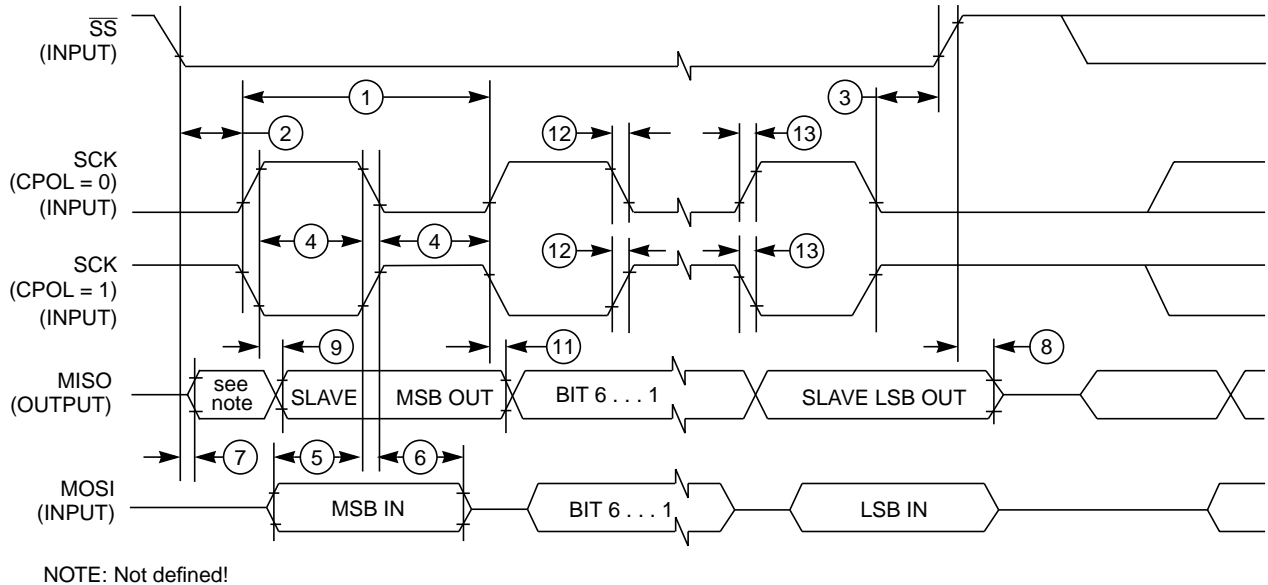

Figure A-8. SPI Slave Timing (CPHA = 1)

In [Table A-18](#) the timing characteristics for slave mode are listed.

Table A-18. SPI Slave Mode Timing Characteristics

Num	C	Characteristic	Symbol	Min	Typ	Max	Unit
1	P	SCK Frequency	f_{sck}	DC	—	1/4	f_{bus}
1	P	SCK Period	t_{sck}	4	—	∞	t_{bus}
2	D	Enable Lead Time	t_{lead}	4	—	—	t_{bus}
3	D	Enable Lag Time	t_{lag}	4	—	—	t_{bus}
4	D	Clock (SCK) High or Low Time	t_{wsck}	4	—	—	t_{bus}
5	D	Data Setup Time (Inputs)	t_{su}	8	—	—	ns
6	D	Data Hold Time (Inputs)	t_{hi}	8	—	—	ns
7	D	Slave Access Time (time to data active)	t_a	—	—	20	ns
8	D	Slave MISO Disable Time	t_{dis}	—	—	22	ns
9	D	Data Valid after SCK Edge	t_{vsck}	—	—	$30 + t_{bus}^1$	ns
10	D	Data Valid after \overline{SS} fall	t_{vss}	—	—	$30 + t_{bus}^1$	ns
11	D	Data Hold Time (Outputs)	t_{ho}	20	—	—	ns
12	D	Rise and Fall Time Inputs	t_{rfi}	—	—	8	ns
13	D	Rise and Fall Time Outputs	t_{rfo}	—	—	8	ns

¹ t_{bus} added due to internal synchronization delay

A.6 ATD Characteristics

This section describes the characteristics of the analog to digital converter.

The ATD is specified and tested for both the 3.3V and 5V range. For ranges between 3.3V and 5V the ATD accuracy is generally the same as in the 3.3V range but is not tested in this range in production test.

A.6.1 ATD Operating Characteristics — 5V Range

The [Table A-19](#) shows conditions under which the ATD operates.

The following constraints exist to obtain full-scale, full range results:

$V_{SSA} \leq V_{RL} \leq V_{IN} \leq V_{RH} \leq V_{DDA}$. This constraint exists since the sample buffer amplifier can not drive beyond the power supply levels that it ties to. If the input level goes outside of this range it will effectively be clipped.

Table A-19. 5V ATD Operating Characteristics

Conditions are shown in Table A-4 unless otherwise noted. Supply Voltage $5V-10\% \leq V_{DDA} \leq 5V+10\%$								
Num	C	Rating	Symbol	Min	Typ	Max	Unit	
1	D	Reference Potential	Low	V_{RL}	V_{SSA}	—	$V_{DDA}/2$	V
			High	V_{RH}	$V_{DDA}/2$	—	V_{DDA}	V
2	C	Differential Reference Voltage ¹	$V_{RH}-V_{RL}$	4.75	5.0	5.25	V	
3	D	ATD Clock Frequency	f_{ATDCLK}	0.5	—	2.0	MHz	
4	D	ATD 10-Bit Conversion Period	Clock Cycles ²	N_{CONV10}	14	—	28	Cycles
			Conv, Time at 2.0MHz ATD Clock f_{ATDCLK}	T_{CONV10}	7	—	14	∞ s
			Conv, Time at 4.0MHz ³ ATD Clock f_{ATDCLK}	T_{CONV10}	3.5	—	7	∞ s
5	D	ATD 8-Bit Conversion Period	Clock Cycles ¹	N_{CONV8}	12	—	26	Cycles
			Conv, Time at 2.0MHz ATD Clock f_{ATDCLK}	T_{CONV8}	6	—	13	∞ s
6	D	Stop Recovery Time ($V_{DDA} = 5.0$ Volts)	t_{SR}	—	—	20	∞ s	
7	P	Reference Supply current	I_{REF}	—	—	0.375	mA	

¹ Full accuracy is not guaranteed when differential voltage is less than 4.75V

² The minimum time assumes a final sample period of 2 ATD clocks cycles while the maximum time assumes a final sample period of 16 ATD clocks.

³ Reduced accuracy see [Table A-22](#) and [Table A-23](#).

A.6.2 ATD Operating Characteristics — 3.3V Range

The [Table A-20](#) shows conditions under which the ATD operates.

The following constraints exist to obtain full-scale, full range results:

$V_{SSA} \leq V_{RL} \leq V_{IN} \leq V_{RH} \leq V_{DDA}$. This constraint exists since the sample buffer amplifier can not drive beyond the power supply levels that it ties to. If the input level goes outside of this range it will effectively be clipped.

Table A-20. 3.3V ATD Operating Characteristics

Conditions are shown in Table A-4 unless otherwise noted; Supply Voltage $3.3V-10\% \leq V_{DDA} \leq 3.3V+10\%$								
Num	C	Rating	Symbol	Min	Typ	Max	Unit	
1	D	Reference Potential	Low	V_{RL}	V_{SSA}	—	$V_{DDA}/2$	V
			High	V_{RH}	$V_{DDA}/2$	—	V_{DDA}	V
2	C	Differential Reference Voltage	$V_{RH}-V_{RL}$	3.0	3.3	3.6	V	
3	D	ATD Clock Frequency	f_{ATDCLK}	0.5	—	2.0	MHz	
4	D	ATD 10-Bit Conversion Period	Clock Cycles ¹	N_{CONV10}	14	—	28	Cycles
			Conv, Time at 2.0MHz ATD Clock f_{ATDCLK}	T_{CONV10}	7	—	14	∞ s
			Conv, Time at 4.0MHz ² ATD Clock f_{ATDCLK}	T_{CONV10}	3.5	—	7	∞ s
5	D	ATD 8-Bit Conversion Period	Clock Cycles ¹	N_{CONV8}	12	—	26	Cycles
			Conv, Time at 2.0MHz ATD Clock f_{ATDCLK}	T_{CONV8}	6	—	13	∞ s
6	D	Recovery Time ($V_{DDA}=3.3$ Volts)	t_{REC}	—	—	20	∞ s	
7	P	Reference Supply current	I_{REF}	—	—	0.250	mA	

¹ The minimum time assumes a final sample period of 2 ATD clocks cycles while the maximum time assumes a final sample period of 16 ATD clocks.

² Reduced accuracy see [Table A-22](#) and [Table A-23](#).

A.6.3 Factors Influencing Accuracy

Three factors — source resistance, source capacitance and current injection — have an influence on the accuracy of the ATD.

A.6.3.1 Source Resistance

Due to the input pin leakage current as specified in [Table A-6](#) and [Table A-7](#) in conjunction with the source resistance there will be a voltage drop from the signal source to the ATD input. The maximum source resistance R_S specifies results in an error of less than 1/2 LSB (2.5mV) at the maximum leakage current. If device or operating conditions are less than worst case or leakage-induced error is acceptable, larger values of source resistance are allowed.

A.6.3.2 Source Capacitance

When sampling an additional internal capacitor is switched to the input. This can cause a voltage drop due to charge sharing with the external and the pin capacitance. For a maximum sampling error of the input voltage ≤ 1 LSB, then the external filter capacitor, $C_f \geq 1024 * (C_{INS} - C_{INN})$.

A.6.3.3 Current Injection

There are two cases to consider.

1. A current is injected into the channel being converted. The channel being stressed has conversion values of 0x3FF (0xFF in 8-bit mode) for analog inputs greater than V_{RH} and 0x000 for values less than V_{RL} unless the current is higher than specified as disruptive conditions.

- Current is injected into pins in the neighborhood of the channel being converted. A portion of this current is picked up by the channel (coupling ratio K), This additional current impacts the accuracy of the conversion depending on the source resistance.

The additional input voltage error on the converted channel can be calculated as

$V_{ERR} = K * R_S * I_{INJ}$, with I_{INJ} being the sum of the currents injected into the two pins adjacent to the converted channel.

Table A-21. ATD Electrical Characteristics

Conditions are shown in Table A-4 unless otherwise noted							
Num	C	Rating	Symbol	Min	Typ	Max	Unit
1	C	Max input Source Resistance	R_S	—	—	1	$K\Omega$
2	T	Total Input Capacitance	C_{INN} C_{INS}	—	—	10	pF
		Non Sampling		—	—	15	
3	C	Disruptive Analog Input Current	I_{NA}	-2.5	—	2.5	mA
4	C	Coupling Ratio positive current injection	K_p	—	—	10^{-4}	A/A
5	C	Coupling Ratio negative current injection	K_n	—	—	10^{-2}	A/A

A.6.4 ATD Accuracy — 5V Range

[Table A-22](#) specifies the ATD conversion performance excluding any errors due to current injection, input capacitance and source resistance.

Table A-22. 5V ATD Conversion Performance

Conditions are shown in Table A-4 unless otherwise noted $V_{REF} = V_{RH} - V_{RL} = 5.12V$. Resulting to one 8 bit count = 20mV and one 10 bit count = 5mV $f_{ATDCLK} = 2.0MHz$							
Num	C	Rating	Symbol	Min	Typ	Max	Unit
1	P	10-Bit Resolution	LSB	—	5	—	mV
2	P	10-Bit Differential Nonlinearity	DNL	-1	—	1	Counts
3	P	10-Bit Integral Nonlinearity	INL	-2.5	—	2.5	Counts
4	P	10-Bit Absolute Error ¹	AE	-2.5	—	2.5	Counts
5	C	10-Bit Absolute Error at $f_{ATDCLK} = 4MHz$	AE	—	± 7.0	—	Counts
6	P	8-Bit Resolution	LSB	—	20	—	mV
7	P	8-Bit Differential Nonlinearity	DNL	-0.5	—	0.5	Counts
8	P	8-Bit Integral Nonlinearity	INL	-1.0	± 0.5	1.0	Counts
9	P	8-Bit Absolute Error ¹	AE	-1.5	± 1.0	1.5	Counts

¹ These values include quantization error which is inherently 1/2 count for any A/D converter.

A.6.5 ATD Accuracy — 3.3V Range

Table A-23 specifies the ATD conversion performance excluding any errors due to current injection, input capacitance and source resistance.

Table A-23. 3.3V ATD Conversion Performance

Conditions are shown in Table A-4 unless otherwise noted $V_{REF} = V_{RH} - V_{RL} = 3.328V$. Resulting to one 8 bit count = 13mV and one 10 bit count = 3.25mV $f_{ATDCLK} = 2.0MHz$							
Num	C	Rating	Symbol	Min	Typ	Max	Unit
1	P	10-Bit Resolution	LSB	—	3.25	—	mV
2	P	10-Bit Differential Nonlinearity	DNL	-1.5		1.5	Counts
3	P	10-Bit Integral Nonlinearity	INL	-3.5	±1.5	3.5	Counts
4	P	10-Bit Absolute Error ¹	AE	-5	±2.5	5	Counts
5	C	10-Bit Absolute Error at $f_{ATDCLK} = 4MHz$	AE	—	±7.0	—	Counts
6	P	8-Bit Resolution	LSB	—	13	—	mV
7	P	8-Bit Differential Nonlinearity	DNL	-0.5	—	0.5	Counts
8	P	8-Bit Integral Nonlinearity	INL	-1.5	±1.0	1.5	Counts
9	P	8-Bit Absolute Error ¹	AE	-2.0	±1.5	2.0	Counts

¹ These values include the quantization error which is inherently 1/2 count for any A/D converter.

For the following definitions see also Figure A-9.

Differential Non-Linearity (DNL) is defined as the difference between two adjacent switching steps.

$$DNL(i) = \frac{V_i - V_{i-1}}{1LSB} - 1$$

The Integral Non-Linearity (INL) is defined as the sum of all DNLs:

$$INL(n) = \sum_{i=1}^n DNL(i) = \frac{V_n - V_0}{1LSB} - n$$

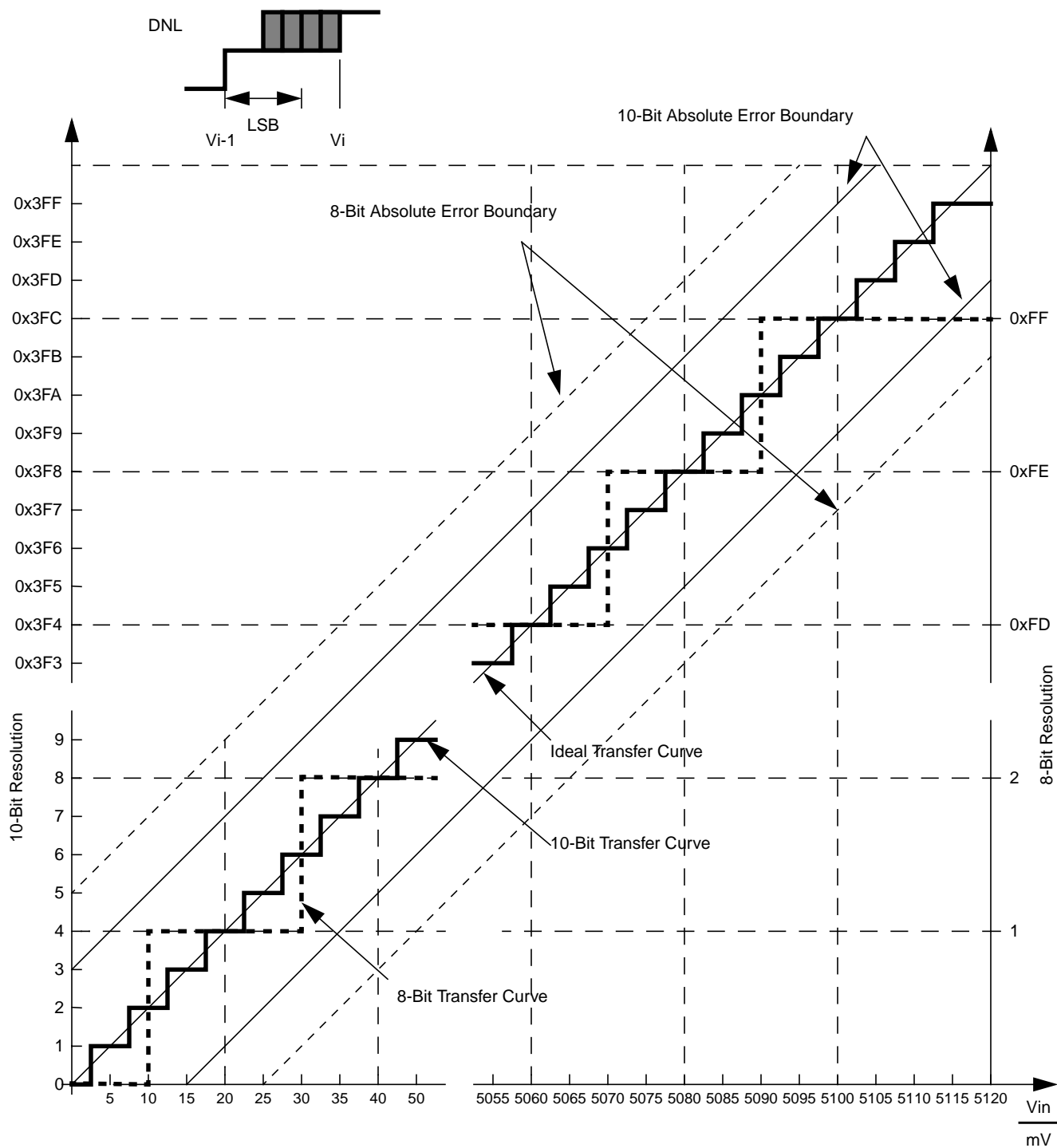

Figure A-9. ATD Accuracy Definitions

NOTE

Figure A-9 shows only definitions, for specification values refer to Table A-22 and Table A-23.

A.7 DAC Characteristics

This section describes the characteristics of the digital to analog converter.

A.7.1 DAC Operating Characteristics

Table A-24. DAC Electrical Characteristics (Operating)

Num	C	Characteristic	Condition	Symbol	Min	Typ	Max	Unit
1	D	DAC Supply		V_{DDA}	2.97	—	5.5	V
2	D	DAC Supply Current	Running	I_{DDArun}	—	—	3.5	mA
	D		Stop (low power)	I_{DDstop}	—	—	1.0	mA
3	D	Reference Potential	Low	V_{SSA}	V_{SSA}	—	V_{SSA}	V
	D		High	V_{REF}	$V_{DDA}/2$	—	V_{DDA}	V
4	D	Reference Supply Current	V_{REF} to V_{SSA}	I_{REF}	—	—	400	∞ A
5	D	Input Current, Channel Off ¹		I_{OFF}	-200	—	1	∞ A
6	D	Operating Temperature Range		T	-40	—	125	$^{\circ}$ C

Table A-25. DAC Timing/Performance Characteristics

Num	C	Parameters	Symbol	Min	Typ	Max	Unit
1	D	DAC Operating Frequency	f_{BUS}	—	—	25	MHz
2	D	Integral Non-Linearity	INL	—	0.25	—	Count
3	D	Differential Non-Linearity	DNL	—	0.10	—	Count
4	D	Resolution	RES	—	—	8	Bit
5	D	Settling Time	T_S	5	—	10	∞ s
6	P	Absolute Accuracy	ABS_{ACC}	-1	—	1	Count
7	D	Offset Error	ERR	—	+/-2.5	—	mV

A.8 External Bus Timing

A timing diagram of the external multiplexed-bus is illustrated in [Figure A-10](#) with the actual timing values shown on [table Table A-26](#) and [Table A-27](#). All major bus signals are included in the diagram. While both a data write and data read cycle are shown, only one or the other would occur on a particular bus cycle.

The expanded bus timings are highly dependent on the load conditions. The timing parameters shown assume a balanced load across all outputs.

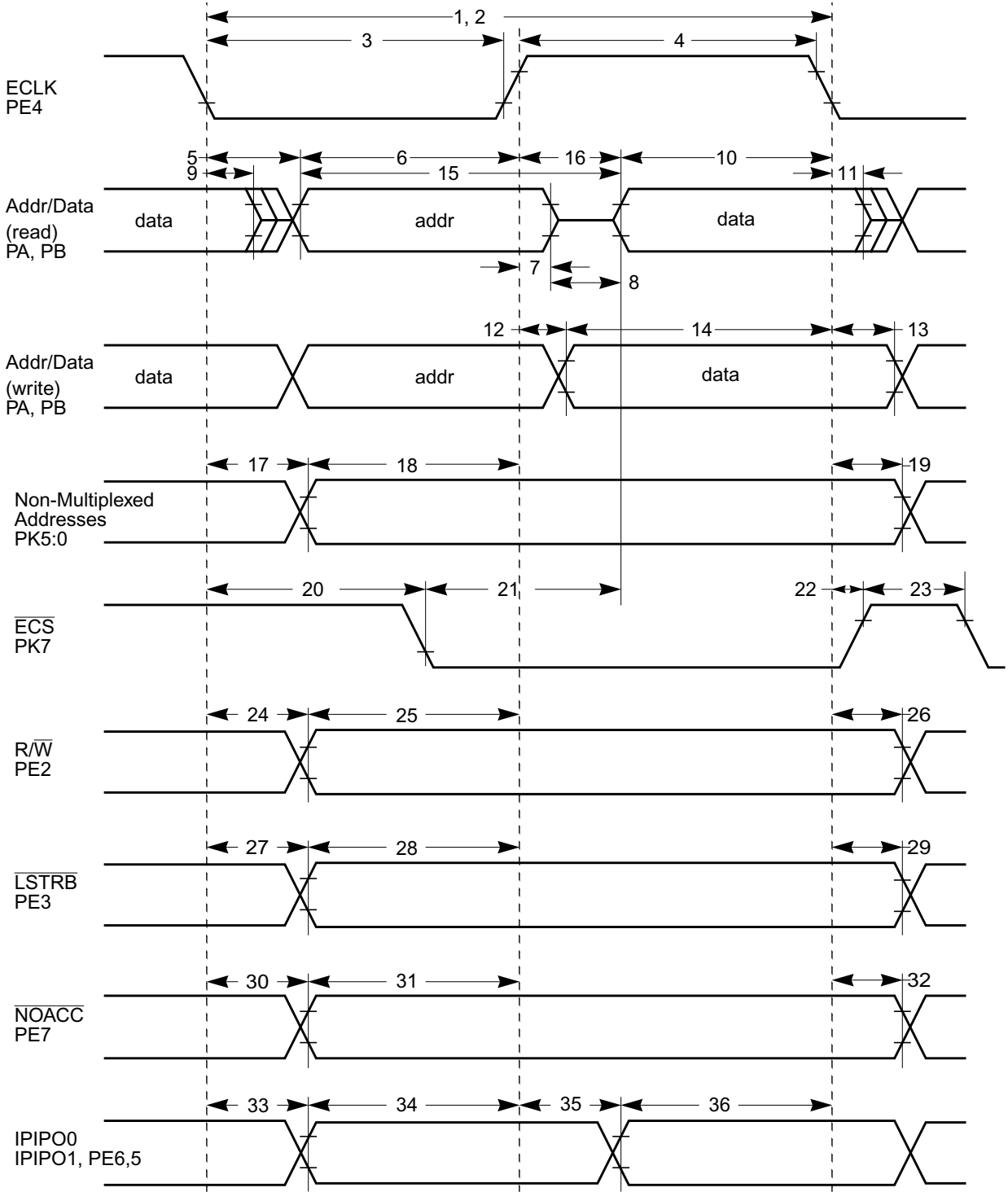

Figure A-10. General External Bus Timing

Table A-26. Expanded Bus Timing Characteristics (5V Range)

Conditions are 4.75V < VDDX < 5.25V, Junction Temperature -40°C to +140°C, C_{LOAD} = 50pF

Num	C	Rating	Symbol	Min	Typ	Max	Unit
1	P	Frequency of operation (E-clock)	f _o	0	—	25.0	MHz
2	P	Cycle time	t _{cyc}	40	—	—	ns
3	D	Pulse width, E low	PW _{EL}	19	—	—	ns
4	D	Pulse width, E high ¹	PW _{EH}	19	—	—	ns
5	D	Address delay time	t _{AD}	—	—	8	ns
6	D	Address valid time to E rise (PW _{EL} -t _{AD})	t _{AV}	11	—	—	ns
7	D	Muxed address hold time	t _{MAH}	2	—	—	ns
8	D	Address hold to data valid	t _{AHDS}	7	—	—	ns
9	D	Data hold to address	t _{DHA}	2	—	—	ns
10	D	Read data setup time	t _{DSR}	13	—	—	ns
11	D	Read data hold time	t _{DHR}	0	—	—	ns
12	D	Write data delay time	t _{DDW}	—	—	7	ns
13	D	Write data hold time	t _{DHW}	2	—	—	ns
14	D	Write data setup time ¹ (PW _{EH} -t _{DDW})	t _{DSW}	12	—	—	ns
15	D	Address access time ¹ (t _{cyc} -t _{AD} -t _{DSR})	t _{ACCA}	19	—	—	ns
16	D	E high access time ¹ (PW _{EH} -t _{DSR})	t _{ACCE}	6	—	—	ns
17	D	Non-multiplexed address delay time	t _{NAD}	—	—	6	ns
18	D	Non-muxed address valid to E rise (PW _{EL} -t _{NAD})	t _{NAV}	14	—	—	ns
19	D	Non-multiplexed address hold time	t _{NAH}	2	—	—	ns
20	D	Chip select delay time	t _{CSD}	—	—	16	ns
21	D	Chip select access time ¹ (t _{cyc} -t _{CSD} -t _{DSR})	t _{ACCS}	11	—	—	ns
22	D	Chip select hold time	t _{CSH}	2	—	—	ns
23	D	Chip select negated time	t _{CSN}	8	—	—	ns
24	D	Read/write delay time	t _{RWD}	—	—	7	ns
25	D	Read/write valid time to E rise (PW _{EL} -t _{RWD})	t _{RWV}	14	—	—	ns
26	D	Read/write hold time	t _{RWH}	2	—	—	ns
27	D	Low strobe delay time	t _{LSD}	—	—	7	ns
28	D	Low strobe valid time to E rise (PW _{EL} -t _{LSD})	t _{LSV}	14	—	—	ns
29	D	Low strobe hold time	t _{LSH}	2	—	—	ns
30	D	NOACC strobe delay time	t _{NOD}	—	—	7	ns
31	D	NOACC valid time to E rise (PW _{EL} -t _{NOD})	t _{NOV}	14	—	—	ns
32	D	NOACC hold time	t _{NOH}	2	—	—	ns
33	D	IPIPO[1:0] delay time	t _{P0D}	2	—	7	ns
34	D	IPIPO[1:0] valid time to E rise (PW _{EL} -t _{P0D})	t _{P0V}	11	—	—	ns
35	D	IPIPO[1:0] delay time ¹ (PW _{EH} -t _{P1V})	t _{P1D}	2	—	25	ns
36	D	IPIPO[1:0] valid time to E fall	t _{P1V}	11	—	—	ns

¹ Affected by clock stretch: add N x t_{cyc} where N=0,1,2 or 3, depending on the number of clock stretches.

Table A-27. Expanded Bus Timing Characteristics (3.3V Range)

Conditions are VDDX=3.3V+/-10%, Junction Temperature -40°C to +140°C, C _{LOAD} = 50pF							
Num	C	Rating	Symbol	Min	Typ	Max	Unit
1	P	Frequency of operation (E-clock)	f_o	0	—	16.0	MHz
2	P	Cycle time	t_{cyc}	62.5	—	—	ns
3	D	Pulse width, E low	PW_{EL}	30	—	—	ns
4	D	Pulse width, E high ¹	PW_{EH}	30	—	—	ns
5	D	Address delay time	t_{AD}	—	—	16	ns
6	D	Address valid time to E rise ($PW_{EL}-t_{AD}$)	t_{AV}	16	—	—	ns
7	D	Muxed address hold time	t_{MAH}	2	—	—	ns
8	D	Address hold to data valid	t_{AHDS}	7	—	—	ns
9	D	Data hold to address	t_{DHA}	2	—	—	ns
10	D	Read data setup time	t_{DSR}	15	—	—	ns
11	D	Read data hold time	t_{DHR}	0	—	—	ns
12	D	Write data delay time	t_{DDW}	—	—	15	ns
13	D	Write data hold time	t_{DHW}	2	—	—	ns
14	D	Write data setup time ¹ ($PW_{EH}-t_{DDW}$)	t_{DSW}	15	—	—	ns
15	D	Address access time ¹ ($t_{cyc}-t_{AD}-t_{DSR}$)	t_{ACCA}	29	—	—	ns
16	D	E high access time ¹ ($PW_{EH}-t_{DSR}$)	t_{ACCE}	15	—	—	ns
17	D	Non-multiplexed address delay time	t_{NAD}	—	—	14	ns
18	D	Non-muxed address valid to E rise ($PW_{EL}-t_{NAD}$)	t_{NAV}	16	—	—	ns
19	D	Non-multiplexed address hold time	t_{NAH}	2	—	—	ns
20	D	Chip select delay time	t_{CSD}	—	—	25	ns
21	D	Chip select access time ¹ ($t_{cyc}-t_{CSD}-t_{DSR}$)	t_{ACCS}	22.5	—	—	ns
22	D	Chip select hold time	t_{CSH}	2	—	—	ns
23	D	Chip select negated time	t_{CSN}	8	—	—	ns
24	D	Read/write delay time	t_{RWD}	—	—	14	ns
25	D	Read/write valid time to E rise ($PW_{EL}-t_{RWD}$)	t_{RWW}	16	—	—	ns
26	D	Read/write hold time	t_{RWH}	2	—	—	ns
27	D	Low strobe delay time	t_{LSD}	—	—	14	ns
28	D	Low strobe valid time to E rise ($PW_{EL}-t_{LSD}$)	t_{LSV}	16	—	—	ns
29	D	Low strobe hold time	t_{LSH}	2	—	—	ns
30	D	NOACC strobe delay time	t_{NOD}	—	—	14	ns
31	D	NOACC valid time to E rise ($PW_{EL}-t_{NOD}$)	t_{NOV}	16	—	—	ns
32	D	NOACC hold time	t_{NOH}	2	—	—	ns
33	D	IPIPO[1:0] delay time	t_{POD}	2	—	14	ns
34	D	IPIPO[1:0] valid time to E rise ($PW_{EL}-t_{POD}$)	t_{POV}	16	—	—	ns
35	D	IPIPO[1:0] delay time ¹ ($PW_{EH}-t_{P1V}$)	t_{P1D}	2	—	25	ns
36	D	IPIPO[1:0] valid time to E fall	t_{P1V}	11	—	—	ns

¹ Affected by clock stretch: add $N \times t_{cyc}$ where $N=0,1,2$ or 3 , depending on the number of clock stretches.

Appendix B Ordering Information and Mechanical Drawings

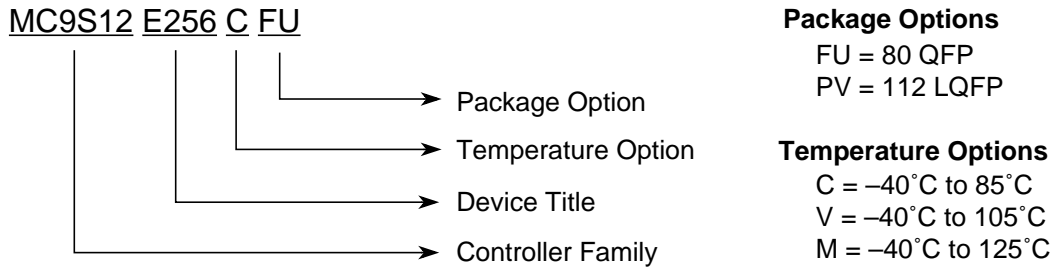

Figure B-1. Order Part Number Coding

Table B-1 lists the part number coding based on the package and temperature.

Table B-1. Part Number Coding

Part Number	Temperature	Package
MC9S12E256CFU	-40°C, 85°C	80 QFP
MC9S12E256CPV	-40°C, 85°C	112 LQFP
MC9S12E256MFU	-40°C, 125°C	80 QFP
MC9S12E256MPV	-40°C, 125°C	112 LQFP

Table B-2 summarizes the package option and size configuration.

Table B-2. Package Option Summary

Part Number	Package	Temp. ¹ Options	Flash	RAM	MEBI	TIM	SCI	SPI	IIC	A/D	D/A	PWM	PMF	KWU	I/O ²
MC9S12E256	112LQFP	M, C	256K	16K	1	12	3	1	1	16	2	6	6	16	92
	80QFP				0										60

¹ C: T_A = 85°C, f = 25MHz. M: T_A = 125°C, f = 25MHz

² I/O is the sum of ports capable to act as digital input or output.

TIM is the number of channels.

A/D is the number of A/D channels.

D/A is the number of D/A channels.

PWM is the number of channels.

PMF is the number of channels.

KWU is the number of key wake up interrupt pins.

I/O is the sum of ports capable to act as digital input or output.





How to Reach Us:

Home Page:

www.freescale.com

USA/Europe or Locations Not Listed:

Freescale Semiconductor
Technical Information Center, CH370
1300 N. Alma School Road
Chandler, Arizona 85224
1-800-521-6274 or 480-768-2130

Europe, Middle East, and Africa:

+44 1296 380 456 (English)
+46 8 52200080 (English)
+49 89 92103 559 (German)
+33 1 69 35 48 48 (French)

Japan:

Freescale Semiconductor Japan Ltd.
Technical Information Center
3-20-1, Minami-Azabu, Minato-ku
Tokyo 106-0047, Japan
0120-191014 or +81-3-3440-3569

Asia/Pacific:

Freescale Semiconductor Hong Kong Ltd.
Technical Information Center
2 Dai King Street
Tai Po Industrial Estate
Tai Po, N.T., Hong Kong
852-26668334

For Literature Requests Only:

Freescale Semiconductor Literature Distribution Center
P.O. Box 5405
Denver, Colorado 80217
1-800-441-2447 or 303-675-2140
Fax: 303-675-2150

Information in this document is provided solely to enable system and software implementers to use Freescale Semiconductor products. There are no express or implied copyright licenses granted hereunder to design or fabricate any integrated circuits or integrated circuits based on the information in this document.

Freescale Semiconductor reserves the right to make changes without further notice to any products herein. Freescale Semiconductor makes no warranty, representation or guarantee regarding the suitability of its products for any particular purpose, nor does Freescale Semiconductor assume any liability arising out of the application or use of any product or circuit, and specifically disclaims any and all liability, including without limitation consequential or incidental damages. "Typical" parameters that may be provided in Freescale Semiconductor data sheets and/or specifications can and do vary in different applications and actual performance may vary over time. All operating parameters, including "Typicals", must be validated for each customer application by customer's technical experts. Freescale Semiconductor does not convey any license under its patent rights nor the rights of others. Freescale Semiconductor products are not designed, intended, or authorized for use as components in systems intended for surgical implant into the body, or other applications intended to support or sustain life, or for any other application in which the failure of the Freescale Semiconductor product could create a situation where personal injury or death may occur. Should Buyer purchase or use Freescale Semiconductor products for any such unintended or unauthorized application, Buyer shall indemnify and hold Freescale Semiconductor and its officers, employees, subsidiaries, affiliates, and distributors harmless against all claims, costs, damages, and expenses, and reasonable attorney fees arising out of, directly or indirectly, any claim of personal injury or death associated with such unintended or unauthorized use, even if such claim alleges that Freescale Semiconductor was negligent regarding the design or manufacture of the part.



Freescale™ and the Freescale logo are trademarks of Freescale Semiconductor, Inc. All other product or service names are the property of their respective owners. The ARM POWERED logo is a registered trademark of ARM Limited. ARM7TDMI-S is a trademark of ARM Limited. Java and all other Java-based marks are trademarks or registered trademarks of Sun Microsystems, Inc. in the U.S. and other countries. The Bluetooth trademarks are owned by their proprietor and used by Freescale Semiconductor, Inc. under license.

© Freescale Semiconductor, Inc. 2005. All rights reserved.