

■ Product introduction

75xx series is a low-power high-voltage regulator manufactured by CMOS process. The maximum input voltage is 30V and the output voltage range is 1.5V~12.0V. It has the characteristics of high precision output voltage, very low power supply current and very low drop voltage.

■ Product features

- Low power consumption: $\leq 3 \mu A$
- Low drop voltage: typical value 0.1V
- Low temperature bleaching: typical 50 ppm / °C
- High input voltage: up to 30V
- High precision output voltage: tolerance of + 3%
- Package form: TO-92, SOT89-3, SOT-23-3, SOT23-5

■ Product use

- Battery power supply equipment
- Audio / video equipment
- Various communication equipment
- Security monitoring equipment

■ Package form and pin function definition

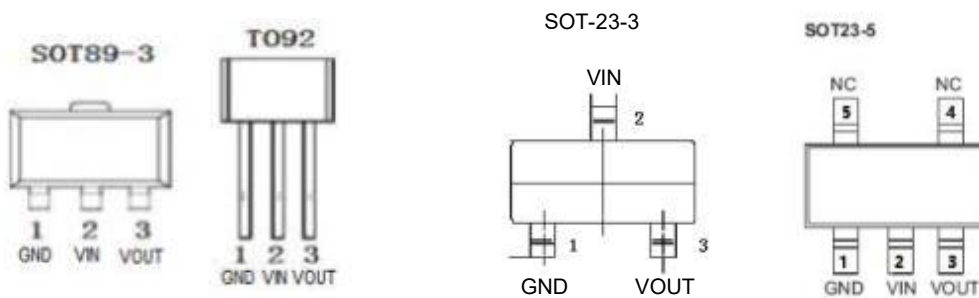

■ Model selection

name	Order Code	Maximum input voltage (V)	Output voltage (V)	tolerance	Package
75XX	7530	30	3.0	±3%	TO92 SOT89-3 SOT-23-3 SOT-23-5
	7533	30	3.3	±3%	
	7536	30	3.6	±3%	
	7544	30	4.4	±3%	
	7550	30	5.0	±3%	

■ Principle block diagram

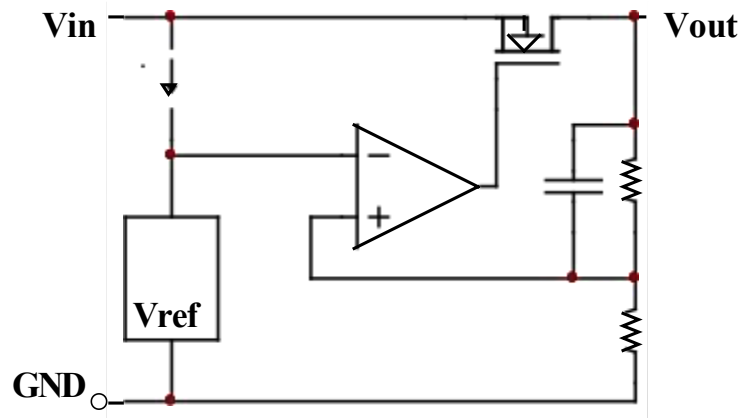

Limit parameter

project	Symbol	parameter		Limit value	Company
Voltage	VIN	Maximum input voltage		30	V
power waste	PD	power waste	T0-92	700	mW
			SOT-23	300	
			SOT-89	400	
			SOT-23-5	300	
temperature	Tw	working temperature		-40~85	°C
	Tc	Storage temperature		-50~125	°C
	Th	welding temperature		260	°C, 10s

Electrical properties

7530 (T_{OPT}=25°C)

Symbol	parameter	Test conditions	minimum value	Typical value	Maximum	Company
V _{OUT}	output voltage	V _{IN} =5V, I _{OUT} =10mA	2.91	3	3.09	V
I _{OUT}	Output current	V _{IN} =5V	60	100		mA
ΔV _{OUT}	Load regulation	V _{IN} =5V, 1mA ≤ I _{OUT} ≤ 20mA	—	100	150	mV
V _{DIF}	Drop voltage	I _{OUT} =1mA	—	100	—	mV
I _{SS}	Quiescent current	V _{IN} = 5V, no load	—	2	3	μA
ΔV _{OUT} / (ΔV _{IN} * V _{OUT})	Line Regulation	4V ≤ V _{IN} ≤ 30V, I _{OUT} =1mA	—	0.2	—	%/V
V _{IN}	input voltage	—	—	—	30	V
ΔV _{OUT} / ΔTa	temperature coefficient	V _{IN} =5V, I _{OUT} =10mA 0°C ≤ Ta ≤ 70°C	—	±0.45	—	mV/°C

7533 (T_{OPT}=25°C)

Symbol	parameter	Test conditions	minimum value	Typical value	Maximum	Company
V _{OUT}	output voltage	V _{IN} =5.5V, I _{OUT} =10mA	3.201	3.3	3.399	V
I _{OUT}	Output current	V _{IN} =5.5V	60	100	—	mA
ΔV _{OUT}	Load regulation	V _{IN} =5.5V, 1mA ≤ I _{OUT} ≤ 30mA	—	100	150	mV
V _{DIF}	Drop voltage	I _{OUT} =1mA	—	100	—	mV
I _{SS}	Quiescent current	V _{IN} = 5.5V, no load	—	2	3	μA
ΔV _{OUT} / (ΔV _{IN} * V _{OUT})	Line Regulation	4.5V ≤ V _{IN} ≤ 30V, I _{OUT} =1mA	—	0.2	—	%/V
V _{IN}	input voltage	—	—	—	30	V
ΔV _{OUT} / ΔTa	temperature coefficient	V _{IN} =5.5V, I _{OUT} =10mA, 0°C ≤ Ta ≤ 70°C	—	±0.5	—	mV/°C

7536 (T_{OPT}=25°C)

Symbol	parameter	Test conditions	minimum value	Typical value	Maximum	Company
V _{OUT}	output voltage	V _{IN} =5.6V, I _{OUT} =10mA	3.492	3.6	3.708	V
I _{OUT}	Output current	V _{IN} =5.6V	60	100	—	mA
ΔV _{OUT}	Load regulation	V _{IN} =5.6V, 1mA ≤ I _{OUT} ≤ 30mA	—	100	150	mV
V _{DIF}	Drop voltage	I _{OUT} =1mA	—	100	—	mV
I _{SS}	Quiescent current	V _{IN} = 5.6V, no load	—	2	3	μA
ΔV _{OUT} / (ΔV _{IN} * V _{OUT})	Line Regulation	4.6V ≤ V _{IN} ≤ 30V, I _{OUT} =1mA	—	0.2	—	%/V
V _{IN}	input voltage	—	—	—	30	V
ΔV _{OUT} / ΔTa	temperature coefficient	V _{IN} =5.6V, I _{OUT} =10mA, 0°C ≤ Ta ≤ 70°C	—	±0.6	—	mV/°C

7544 (T_{OPT}=25°C)

Symbol	parameter	Test conditions	minimum value	Typical value	Maximum	Company
V _{OUT}	output voltage	V _{IN} =6.4V, I _{OUT} =10mA	4.268	4.4	4.532	V
I _{OUT}	Output current	V _{IN} =6.4V	60	100	—	mA
ΔV _{OUT}	Load regulation	V _{IN} =6.4V, 1mA ≤ I _{OUT} ≤ 30mA	—	100	150	mV
V _{DIF}	Drop voltage	I _{OUT} =1mA	—	100	—	mV
I _{SS}	Quiescent current	V _{IN} = 6.4V, no load	—	2	3	μA
ΔV _{OUT} / (ΔV _{IN} * V _{OUT})	Line Regulation	5.4V ≤ V _{IN} ≤ 30V, I _{OUT} =1mA	—	0.2	—	%/V
V _{IN}	input voltage	—	—	—	30	V
ΔV _{OUT} / ΔTa	temperature coefficient	V _{IN} =6.4V, I _{OUT} =10mA, 0°C ≤ Ta ≤ 70°C	—	±0.7	—	mV/°C

7550 (T_{OPT}=25°C)

Symbol	parameter	Test conditions	minimum value	Typical value	Maximum	Company
V _{OUT}	output voltage	V _{IN} = 7V, I _{OUT} = 10mA	4.85	5	5.15	V
I _{OUT}	Output current	V _{IN} = 7V	60	100	—	mA
ΔV _{OUT}	Load regulation	V _{IN} = 7V, 1mA ≤ I _{OUT} ≤ 30mA	—	100		mV
V _{DIF}	Drop voltage	I _{OUT} = 1mA	—	100	—	mV
I _{SS}	Quiescent current	V _{in} = 7V, no load	—	2	3	μA
ΔV _{OUT} / (ΔV _{IN} * V _{OUT})	Line Regulation	6V ≤ V _{IN} ≤ 30V, I _{OUT} = 1mA	—	0.2	—	%/V
V _{IN}	input voltage	—	—	—	30	V
ΔV _{OUT} / ΔTa	temperature coefficient	V _{IN} = 7V, I _{OUT} = 10mA, 0°C ≤ Ta ≤ 70°C	—	±0.75	—	mV/°C

Application circuit

1. Basic circuit

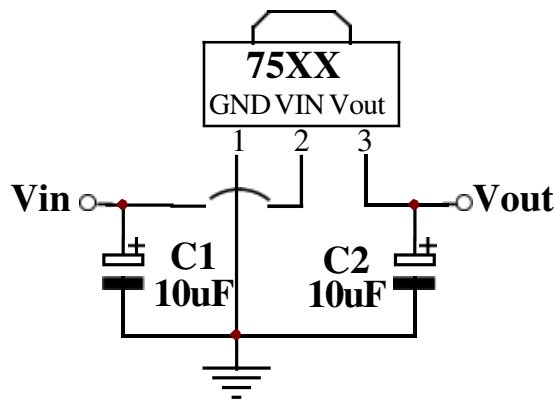

2. High output current regulator

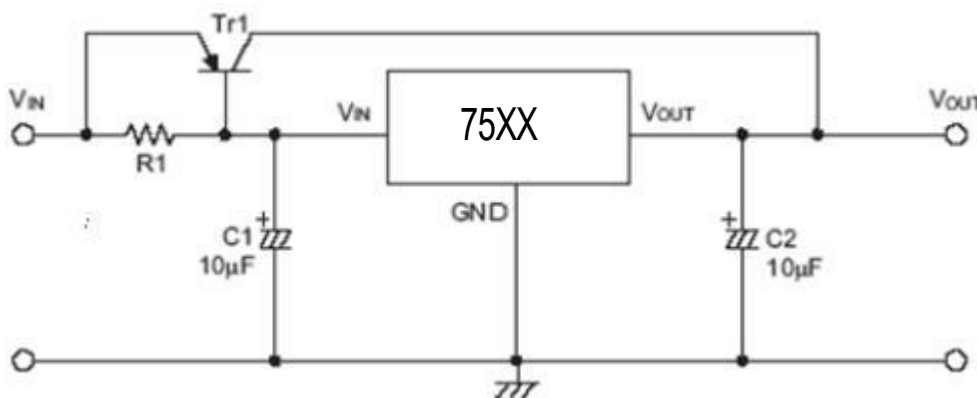

3. Short circuit protection circuit

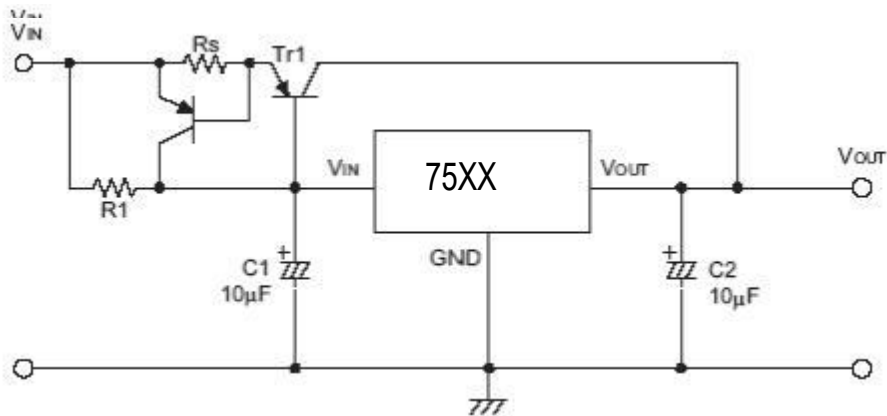

4. Circuit for increasing output voltage (1)

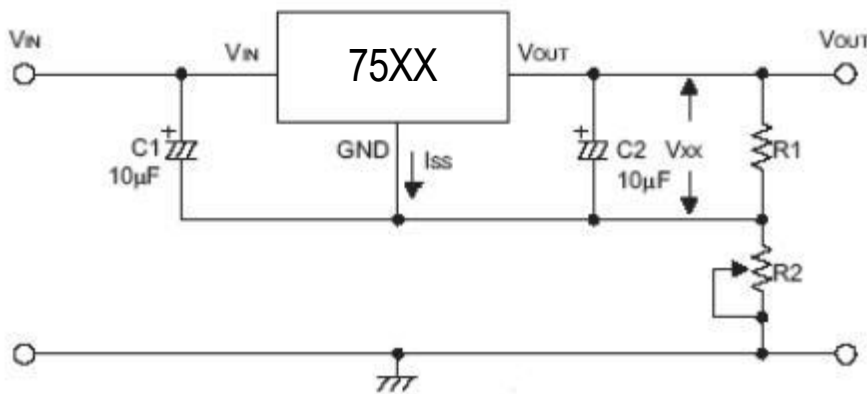

$$V_{OUT} = V_{XX} (1 + R2/R1) + I_{SS} * R2$$

5. Circuit for increasing output voltage (2)

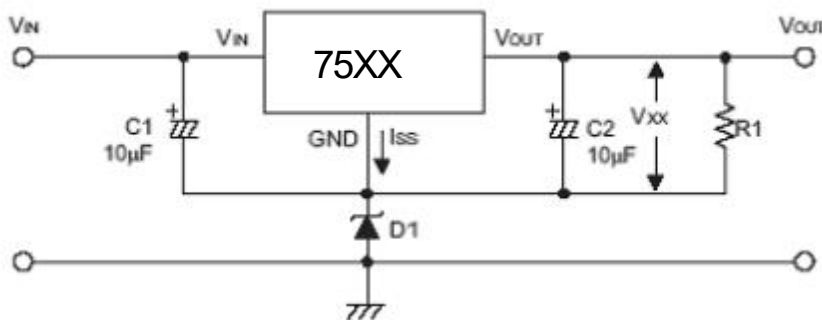

$$V_{OUT} = V_{XX} + V_{D1}$$

6. Current regulating circuit

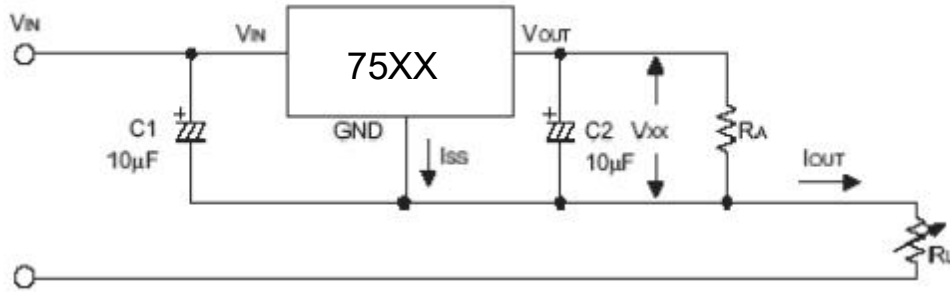

$$I_{OUT} = V_{XX}/R_X + I_{SS}$$

7. Dual output circuit

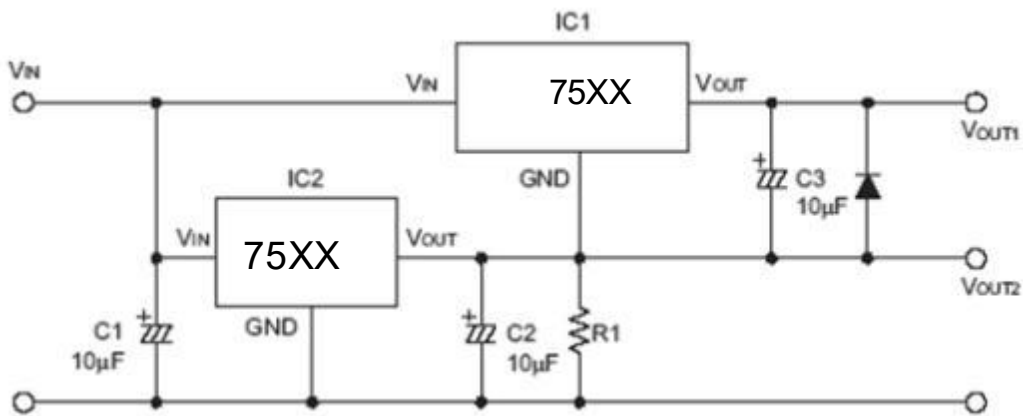

Note: “××” Represents the output voltage

■ Encapsulation information

T0-92

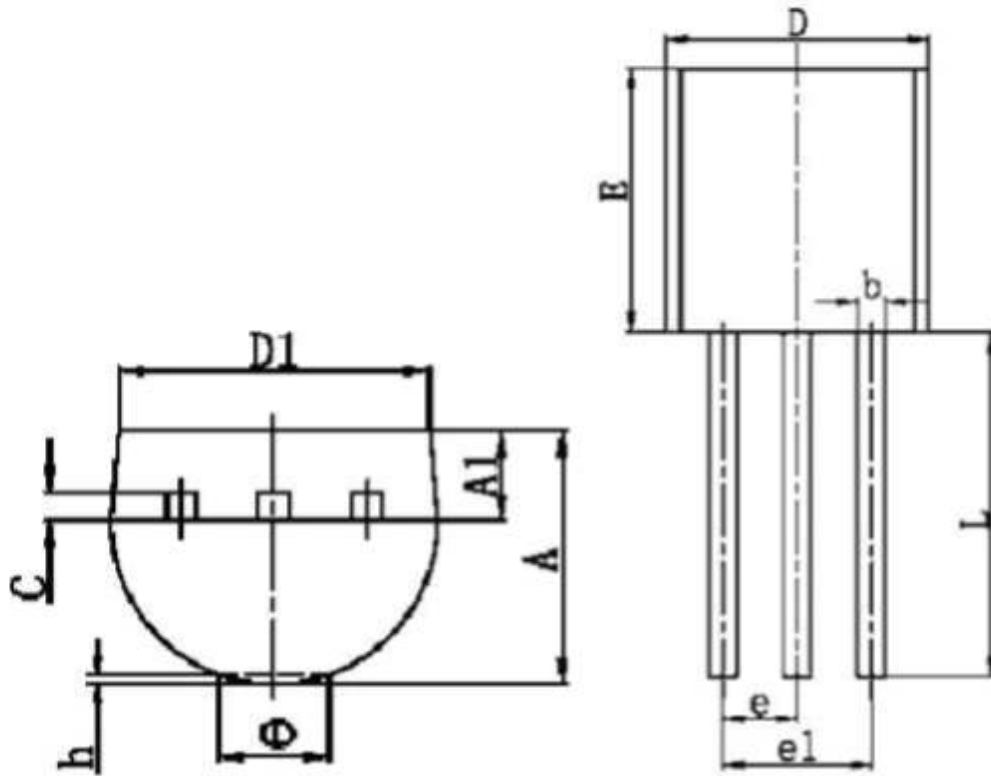

Symbol	minimum(mm)	Maximum(mm)
A	3.300	3.700
AL	1.100	1.400
b	0.380	0.550
c	0.360	0.510
D	4.400	4.700
D1	3.430	
E	4.300	4.700
e	1.270 TYP	
e1	2.440	2.640
L	14.100	14.500
Φ		1.600
h	0.000	0.380

SOT-89-3

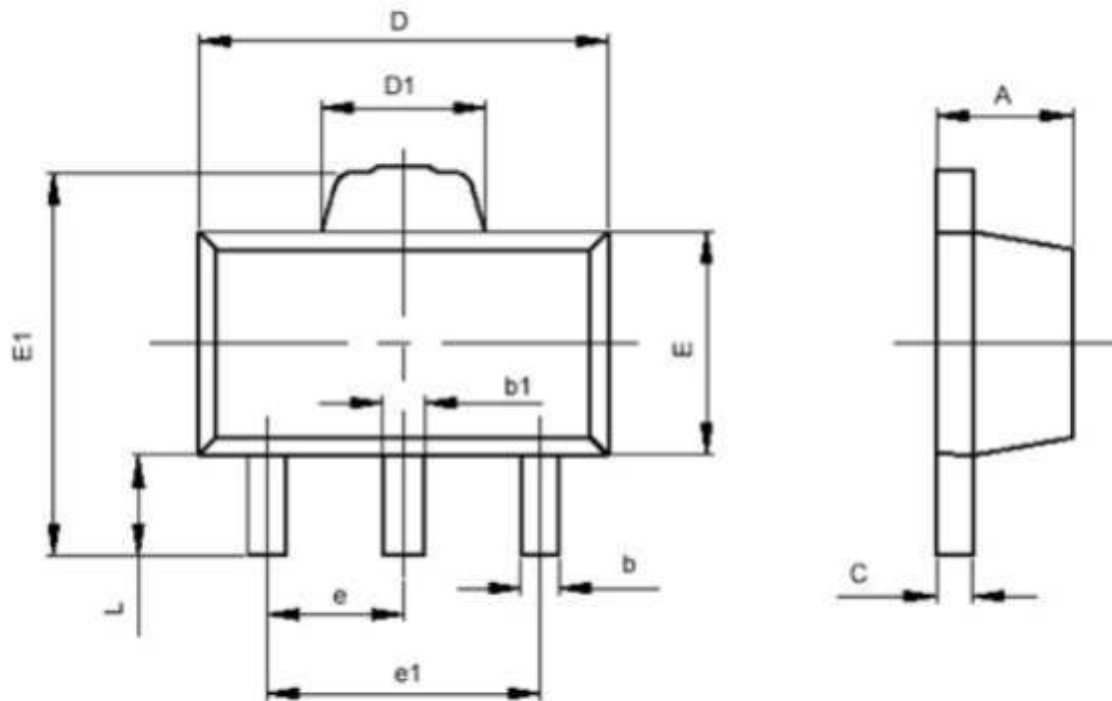

Symbol	minimum(mm)	Maximum (mm)
A	1.400	1.600
b	0.320	0.520
b1	0.360	0.560
c	0.350	0.440
D	4.400	4.600
D1	1.400	1.800
E	2.300	2.600
E1	3.940	4.250
e	1.500TYP	
e1	2.900	3.100
L	0.900	1.100

SOT-23-3

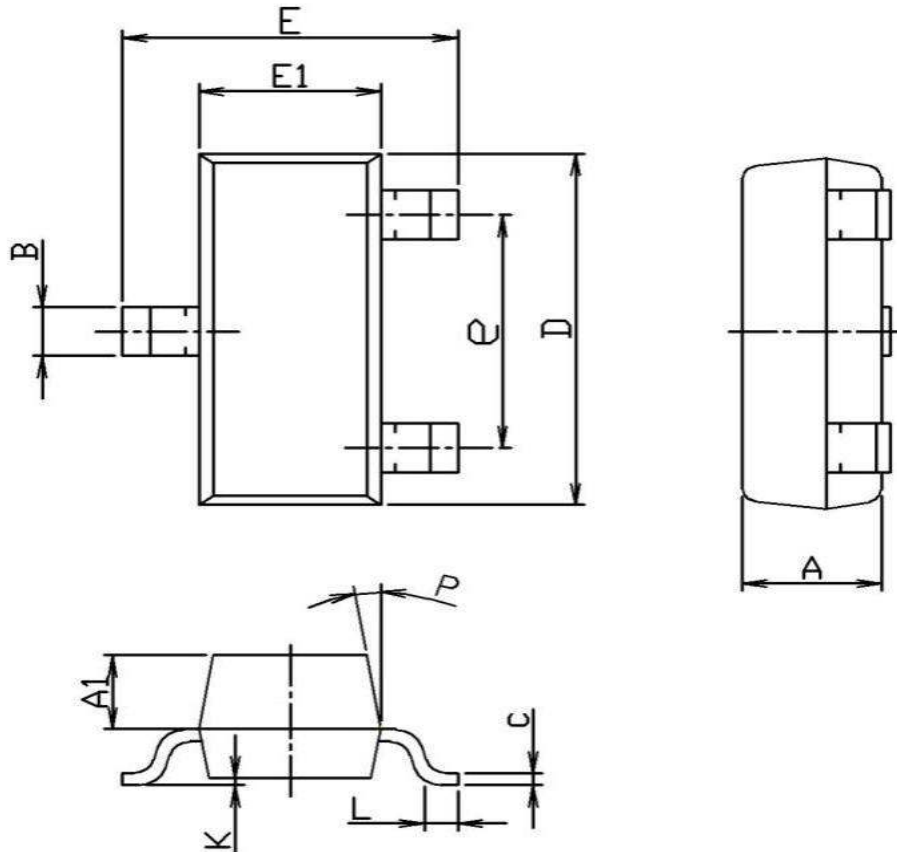

SOT-23-3		Unit: mm	
Symbol	Min	TYP	Max
A	0.90	1.00	1.20
A1	0.55	0.60	0.70
B	0.35	0.40	0.55
C	0.06	0.10	0.15
D	2.70	2.90	3.10
E	2.20	2.40	2.60
E1	1.20	1.30	1.50
e	1.80	1.90	2.00
K	0	0.08	0.18
L	0.25		
p	5°	7°	9°

SOT-23-5

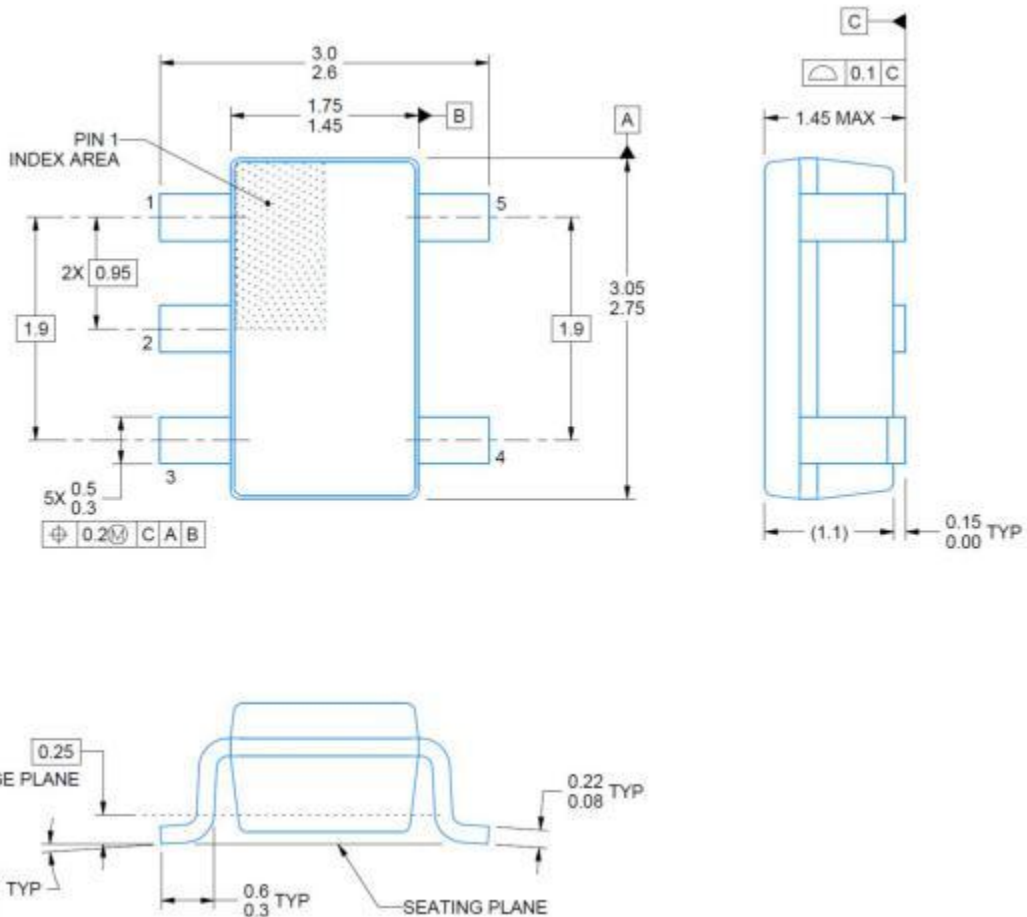

Ordering information

Order code	Package	Baseqty	Deliverymode
UMW HT75xx-1	SOT-89	1000	Tape and reel
UMW HT75xxS	SOT-23	3000	Tape and reel
UMW HT75xxA-1	TO-92	1000	Tape and reel
UMW HT75xxS-2	SOT23-5	3000	Tape and reel