

FEATURES

- Complete single-chip JPEG2000 compression and decompression solution for video and still images
- Patented SURF® (spatial ultra-efficient recursive filtering) technology enables low power and low cost wavelet-based compression
- Supports both 9/7 and 5/3 wavelet transforms with up to 6 levels of transform
- Programmable tile/image size with widths up to 2048 pixels in 3-component 4:2:2 interleaved mode, and up to 4096 pixels in single-component mode
- Maximum tile/image width: 4096 pixels
- Video interface directly supporting ITU.R-BT656, SMPTE125M PAL/ NTSC, SMPTE274M, SMPTE293M (525p), ITU.R-BT1358 (625p) or any video format with a maximum input rate of 65 MSPS for irreversible mode or 40 MSPS for reversible mode
- Two or more ADV202s can be combined to support full-frame SMPTE274M HDTV (1080i) or SMPTE296M (720p)
- Flexible asynchronous SRAM-style host interface allows glueless connection to most 16-/32-bit microcontrollers and ASICs
- 2.5 V to 3.3 V I/O and 1.5 V core supply
- 12 mm × 12 mm 121-lead CSPBGA, speed grade 115 MHz, or
- 13 mm × 13 mm 144-lead CSPBGA, speed grade 135 MHz, or
- 13 mm × 13 mm 144-lead CSPBGA, speed grade 150 MHz

APPLICATIONS

- Networked video and image distribution systems
- Wireless video and image distribution
- Image archival/retrieval
- Digital CCTV and surveillance systems
- Digital cinema systems
- Professional video editing and recording
- Digital still cameras
- Digital camcorders

GENERAL DESCRIPTION

The ADV202 is a single-chip JPEG2000 codec targeted for video and high bandwidth image compression applications that can benefit from the enhanced quality and feature set provided by the JPEG2000 (J2K)—ISO/IEC15444-1 image compression standard. The part implements the computationally intensive operations of the JPEG2000 image compression standard as well as providing fully compliant code-stream generation for most applications.

The ADV202's dedicated video port provides glueless connection to common digital video standards such as ITU.R-BT656, SMPTE125M, SMPTE293M (525p), ITU.R-BT1358 (625p), SMPTE274M (1080i), or SMPTE296M (720p). A variety of other high speed, synchronous pixel and video formats can also be supported using the programmable framing and validation signals.

(continued on Page 4)

FUNCTIONAL BLOCK DIAGRAM

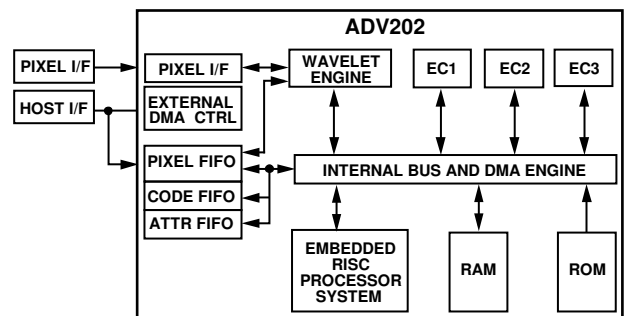

Figure 1.

Rev. D

Information furnished by Analog Devices is believed to be accurate and reliable. However, no responsibility is assumed by Analog Devices for its use, nor for any infringements of patents or other rights of third parties that may result from its use. Specifications subject to change without notice. No license is granted by implication or otherwise under any patent or patent rights of Analog Devices. Trademarks and registered trademarks are the property of their respective owners.

TABLE OF CONTENTS

Features	1	Embedded Processor System	26
Applications.....	1	Memory System.....	26
General Description	1	Internal DMA Engine	26
Functional Block Diagram	1	ADV202 Interface.....	27
Revision History	3	Video Interface (VDATA Bus).....	27
General Description	4	Host Interface (HDATA Bus)	27
JPEG2000 Feature Support.....	4	Direct and Indirect Registers	27
Specifications.....	5	Control Access Registers	27
Supply Voltages and Current	5	Pin Configuration and Bus Sizes/Modes	28
Input/Output Specifications.....	5	Stage Register	28
Clock and $\overline{\text{RESET}}$ Specifications	6	JDATA Mode.....	28
Normal Host Mode—Read Operation	7	External DMA Engine	28
Normal Host Mode—Write Operation	8	Internal Registers.....	29
$\overline{\text{DREQ}}/\overline{\text{DACK}}$ DMA Mode—Single FIFO Write Operation ..	9	Direct Registers.....	29
$\overline{\text{DREQ}}/\overline{\text{DACK}}$ DMA Mode—Single FIFO Read Operation .	11	Indirect Registers.....	30
External DMA Mode—FIFO Write, Burst Mode	13	PLL	31
External DMA Mode—FIFO Read, Burst Mode	14	Hardware Boot.....	31
Streaming Mode (JDATA)—FIFO Read/Write.....	16	Video Input Formats	32
VDATA Mode Timing	17	Applications.....	34
Raw Pixel Mode Timing	18	Encode—Multichip Mode.....	34
Absolute Maximum Ratings.....	19	Decode—Multichip Master/Slave	35
Thermal Resistance	19	Digital Still Camera/Camcorder	35
ESD Caution.....	19	Encode/Decode SDTV Video Application	36
Pin BGA Assignments and Function Descriptions	20	ASIC Application (32-Bit Host/32-Bit ASIC).....	37
Pin BGA Assignments	20	HIPI (Host Interface—Pixel Interface)	38
Pin Function Descriptions	23	JDATA Interface	38
Theory of Operation	26	Outline Dimensions	39
Wavelet Engine	26	Ordering Guide	40
Entropy Codecs.....	26		

REVISION HISTORY**1/12—Rev. C to Rev. D**

Updated Outline Dimensions.....	39
Changes to Ordering Guide.....	40

11/06—Rev. B to Rev. C

Deleted ANC FIFO References	Universal
Changes to Features	1
Changes to Figure 1.....	1
Changes to JPEG2000 Feature Support Section.....	4
Changes to Figure 8.....	10
Changes to Figure 10	11
Changes to Figure 12	12
Changes to External DMA Mode—FIFO Write, Burst Mode Section.....	13
Changes to External DMA Mode—FIFO Read, Burst Mode Section.....	13
Changes to Table 11	17
Changes to Figure 22	18
Deleted SPI Port Timing Section	18
Added Absolute Maximum Ratings Section	19

Changes to Pin BGA Assignments and Function

Descriptions Section	20
Changes to ADV202 Interface Section	27
Changes to Table 19	29
Changes to Indirect Registers Section	30
Changes to PLL Section.....	31
Changes to Table 23	31
Changes to Video Input Formats Section	32
Changes to Figure 24	34
Changes to Figure 26	35
Changes to Ordering Guide.....	40

1/05—Rev. A to Rev. B

Updated Outline Dimensions.....	39
---------------------------------	----

12/04—Rev. 0 to Rev. A

Changes to Features	1
Changes to Table 2	4
Changes to Table 16	24
Changes to Table 23	32

7/04—Revision 0: Initial Version

GENERAL DESCRIPTION

(continued from Page 1)

The ADV202 can process images at a rate of 40 MSPS in reversible mode and at higher rates when used in irreversible mode. The ADV202 contains a dedicated wavelet transform engine, three entropy codecs, an on-board memory system, and an embedded RISC processor that can provide a complete JPEG2000 compression/decompression solution.

The wavelet processor supports the 9/7 irreversible wavelet transform and the 5/3 wavelet transform in reversible and irreversible modes. The entropy codecs support all features in the JPEG2000 Part 1 specification, except Maxshift ROI.

The ADV202 operates on a rectangular array of pixel samples called a tile. A tile can contain a complete image, up to the maximum supported size, or some portion of an image. The maximum horizontal tile size supported depends on the wavelet transform selected and the number of samples in the tile. Images larger than the ADV202's maximum tile size can be broken into individual tiles and then sent sequentially to the chip while still maintaining a single, fully compliant JPEG2000 code stream for the entire image.

JPEG2000 FEATURE SUPPORT

The ADV202 supports a broad set of features that are included in Part 1 of the JPEG2000 standard (ISO/IEC 15444). See [Getting Started with ADV202](#) for information on the JPEG2000 features that the ADV202 currently supports.

Depending on the particular application requirements, the ADV202 can provide varying levels of JPEG2000 compression support. It can provide raw code-block and attribute data output, which allow the host software to have complete control over the generation of the JPEG2000 code stream and other aspects of the compression process such as bit-rate control. Otherwise, the ADV202 can create a complete, fully compliant JPEG2000 code stream (.j2c) and enhanced file formats such as .jp2 and .j2c. See [Getting Started with ADV202](#) for information on the formats that the ADV202 currently supports.

Application notes and other ADV202 support documents can be accessed over the ADV202 product page at:

- <http://www.analog.com/ADV202Notes> or from
- ftp://ftp.analog.com/pub/Digital_Imaging/ADV202_FTP_site_contents_3.html

SPECIFICATIONS

SUPPLY VOLTAGES AND CURRENT

Table 1.

Parameter	Description	Min	Typ	Max	Unit
VDD	DC Supply Voltage, Core	1.425	1.5	1.575	V
IOVDD	DC Supply Voltage, I/O	2.375	3.3	3.63	V
PLLVD	DC Supply Voltage, PLL	1.425	1.5	1.575	V
V _{INPUT}	Input Range	-0.3		V _{DD/I/O} + 0.3	V
Temp	Operating Ambient Temperature Range in Free Air	-40	+25	+85	°C
I _{DD}	Static Current ¹			300	mA
	Dynamic Current, Core (JCLK Frequency = 150 MHz) ²			570	mA
	Dynamic Current, Core (JCLK Frequency = 108 MHz)			420	mA
	Dynamic Current, Core (JCLK Frequency = 81 MHz)			325	mA
	Dynamic Current, I/O			20	mA
	Dynamic Current, PLL			2.6	mA

¹ No clock or I/O activity.

² ADV202-150 only.

INPUT/OUTPUT SPECIFICATIONS

Table 2.

Parameter	Description	Test Conditions	Min	Typ	Max	Unit
V _{IH} (3.3 V)	High Level Input Voltage	VDD = max	2.2			V
V _{IH} (2.5 V)	High Level Input Voltage	VDD = max	1.9			V
V _{IL} (3.3 V, 2.5 V)	Low Level Input Voltage	VDD = min			0.6	V
V _{OH} (3.3 V)	High Level Output Voltage	VDD = min, I _{OH} = -0.5 mA	2.4			V
V _{OH} (2.5 V)	High Level Output Voltage	VDD = min, I _{OH} = -0.5 mA	2.0			V
V _{OL} (3.3 V, 2.5 V)	Low Level Output Voltage	VDD = min, I _{OL} = 2 mA			0.4	V
I _{IH}	High Level Input Current	VDD = max, V _{IN} = VDD	1.0			μA
I _{IL}	Low Level Input Current	VDD = max, V _{IN} = 0 V			1	μA
I _{OZH}	High Level Three-State Leakage Current	VDD = max, V _{IN} = VDD	1.0			μA
I _{OZL}	Low Level Three-State Leakage Current	VDD = max, V _{IN} = 0 V			1.0	μA
C _I	Input Pin Capacitance				8	pF
C _O	Output Pin Capacitance				8	pF

CLOCK AND RESET SPECIFICATIONS

Table 3.

Parameter	Description	Min	Typ	Max	Unit
t_{MCLK}	MCLK ¹ Period	13.3		100	ns
t_{MCLKL}	MCLK Width Low	6			ns
t_{MCLKH}	MCLK Width High	6			ns
t_{VCLK}	VCLK Period	13.4		50	ns
t_{VCLKL}	VCLK Width Low	5			ns
t_{VCLKH}	VCLK Width High	5			ns
t_{RST}	RESET Width Low	5			MCLK cycles

¹ For a definition of MCLK, see the PLL section.

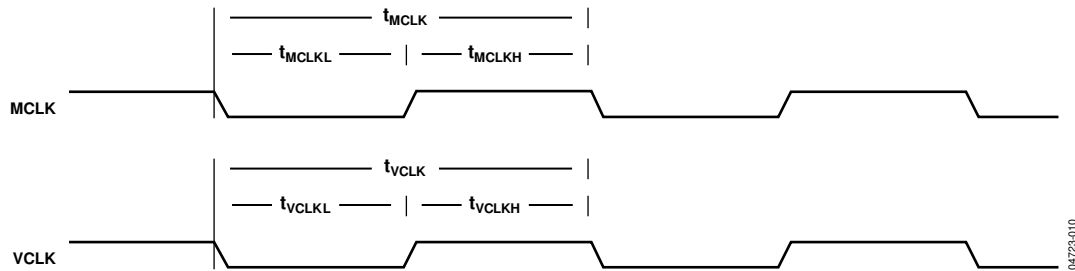

Figure 2. Input Clock

04723-010

NORMAL HOST MODE—READ OPERATION

Table 4.

Parameter	Description	Min	Typ	Max	Unit
$t_{\overline{ACK}} [\text{dir}]$	\overline{RD} to \overline{ACK} , Direct Registers and FIFO Accesses	5		$1.5 \times \text{JCLK}^1 + 7.0$	ns
$t_{\overline{ACK}} [\text{indir}]$	\overline{RD} to \overline{ACK} , Indirect Registers	$10.5 \times \text{JCLK}$		$15.5 \times \text{JCLK} + 7.0$	ns
$t_{\text{DRD}} [\text{dir}]$	Read Access Time, Direct Registers	5		$1.5 \times \text{JCLK} + 7.0$	ns
$t_{\text{DRD}} [\text{indir}]$	Read Access Time, Indirect Registers	$10.5 \times \text{JCLK}$		$15.5 \times \text{JCLK} + 7.0$	ns
t_{HZRD}	Data Hold	2		8.5	ns
t_{SC}	\overline{CS} to \overline{RD} Setup	0			ns
t_{SA}	Address Setup	2			ns
t_{HC}	\overline{CS} Hold	0			ns
t_{HA}	Address Hold	2			ns
t_{RH}	Read Inactive Pulse Width	2.5			JCLK
t_{RL}	Read Active Pulse Width	2.5			JCLK
t_{RCYC}	Read Cycle Time, Direct Registers	5.0			JCLK

¹ For a definition of JCLK, see the PLL section.

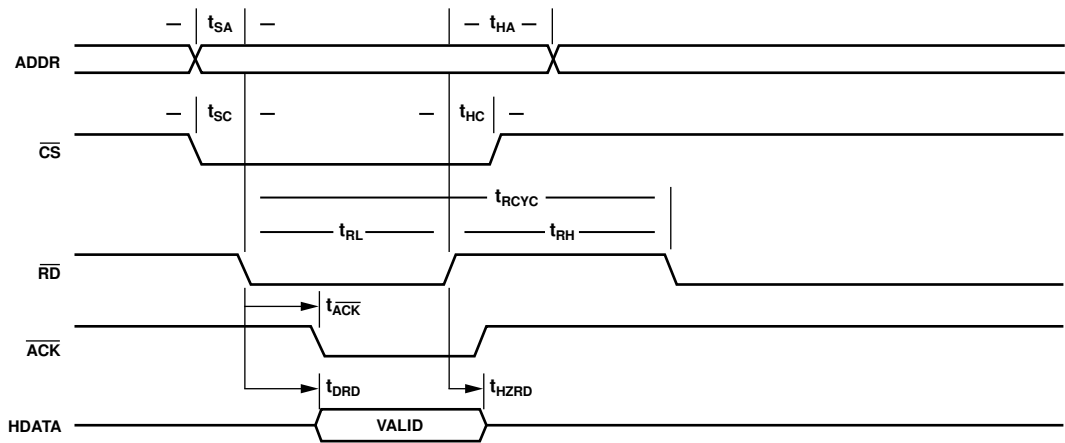

Figure 3. Normal Host Mode—Read Operation

04723-011

NORMAL HOST MODE—WRITE OPERATION

Table 5.

Parameter	Description	Min	Typ	Max	Unit
t_{ACK}^- (Direct)	\overline{WE} to \overline{ACK} , Direct Registers and FIFO Accesses	5		$1.5 \times JCLK^1 + 7.0$	ns
t_{ACK}^- (Indirect)	\overline{WE} to \overline{ACK} , Indirect Registers	5		$2.5 \times JCLK + 7.0$	ns
t_{SD}	Data Setup	3.0			ns
t_{HD}	Data Hold	1.5			ns
t_{SA}	Address Setup	2			ns
t_{HA}	Address Hold	2			ns
t_{SC}	\overline{CS} to \overline{WE} Setup	0			ns
t_{HC}	\overline{CS} Hold	0			ns
t_{WH}	Write Inactive Pulse Width (Minimum Time Until Next \overline{WE} Pulse)	2.5			JCLK
t_{WL}	Write Active Pulse Width	2.5			JCLK
t_{WCYC}	Write Cycle Time	5			JCLK

¹ For a definition of JCLK, see the PLL section.

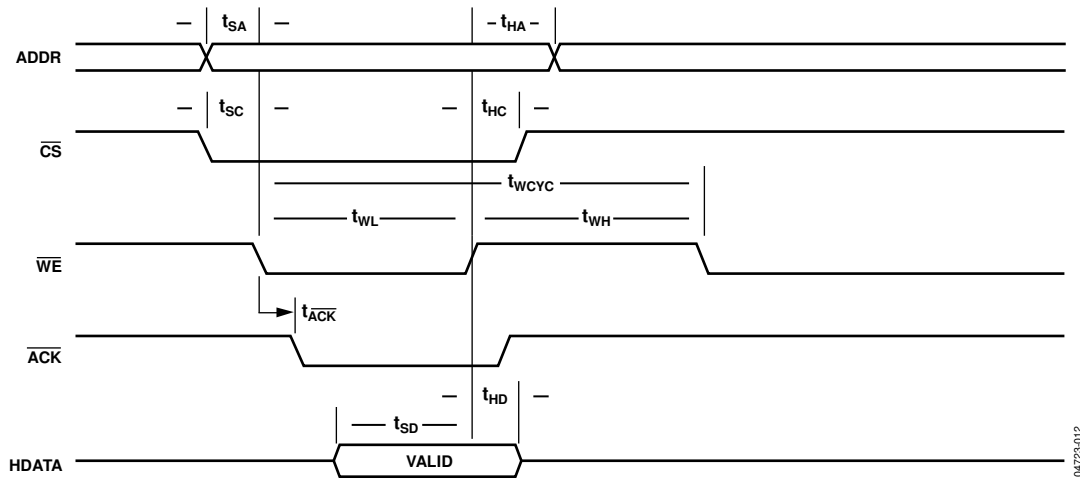

Figure 4. Normal Host Mode—Write Operation

04723-012

DREQ/DACK DMA MODE—SINGLE FIFO WRITE OPERATION

Table 6.

Parameter	Description	Min	Typ	Max	Unit
$\overline{\text{DREQ}}_{\text{PULSE}}^1$	$\overline{\text{DREQ}}$ Pulse Width	1		15	JCLK cycles ²
$t_{\overline{\text{DREQ}}}$	$\overline{\text{DACK}}$ Assert to Subsequent $\overline{\text{DREQ}}$ Delay	2.5		$3.5 \times \text{JCLK} + 7.5 \text{ ns}$	JCLK cycles
$t_{\overline{\text{WE}}\text{SU}}$	$\overline{\text{WE}}$ to $\overline{\text{DACK}}$ Setup	0			ns
t_{SU}	Data to $\overline{\text{DACK}}$ Deassert Setup	2			ns
t_{HD}	Data to $\overline{\text{DACK}}$ Deassert Hold	2			ns
$\overline{\text{DACK}}_{\text{LO}}$	$\overline{\text{DACK}}$ Assert Pulse Width	2			JCLK cycles
$\overline{\text{DACK}}_{\text{HI}}$	$\overline{\text{DACK}}$ Deassert Pulse Width	2			JCLK cycles
$t_{\overline{\text{WE}}\text{HD}}$	$\overline{\text{WE}}$ Hold After $\overline{\text{DACK}}$ Deassert	0			ns
$\overline{\text{WFSRQ}}$	$\overline{\text{WE}}$ Assert to $\overline{\text{FSRQ}}$ Deassert (FIFO Full)	1.5		$2.5 \times \text{JCLK} + 7.5 \text{ ns}$	JCLK cycles
$t_{\overline{\text{DREQ}}\text{RTN}}$	$\overline{\text{DACK}}$ to $\overline{\text{DREQ}}$ Deassert ($\text{DR} \times \text{PULS} = 0$)	2.5		$3.5 \times \text{JCLK} + 7.5 \text{ ns}$	JCLK cycles

¹ Applies to assigned DMA channel, if EDMOD0 or EDMOD1[14:11] is programmed to a value that is not 0. Pulse width depends on the value programmed
² For a definition of JCLK, see the PLL section.

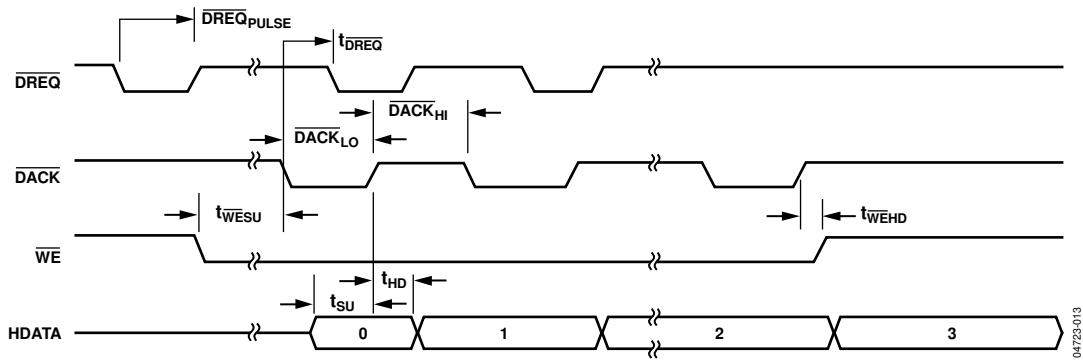

Figure 5. Single Write for $\overline{\text{DREQ}}/\overline{\text{DACK}}$ DMA Mode for Assigned DMA Channel (EDMOD0/EDMOD1[14:11] NOT Programmed to a Value of 0000)

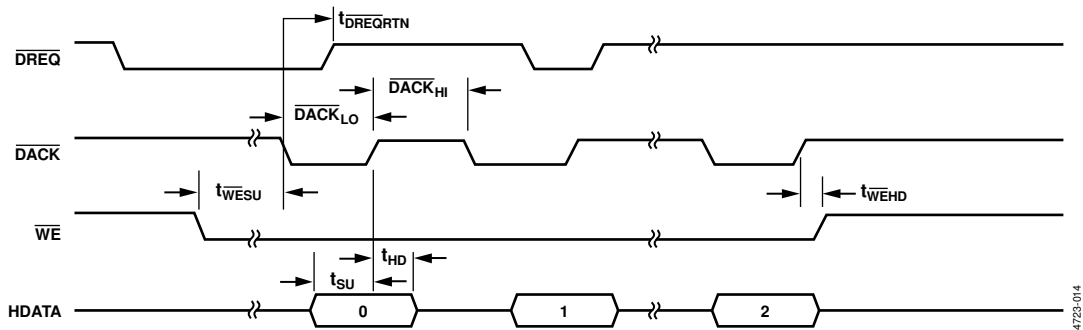

Figure 6. Single Write for $\overline{\text{DREQ}}/\overline{\text{DACK}}$ DMA Mode for Assigned DMA Channel (EDMOD0/EDMOD1[14:11] Programmed to a Value of 0000)

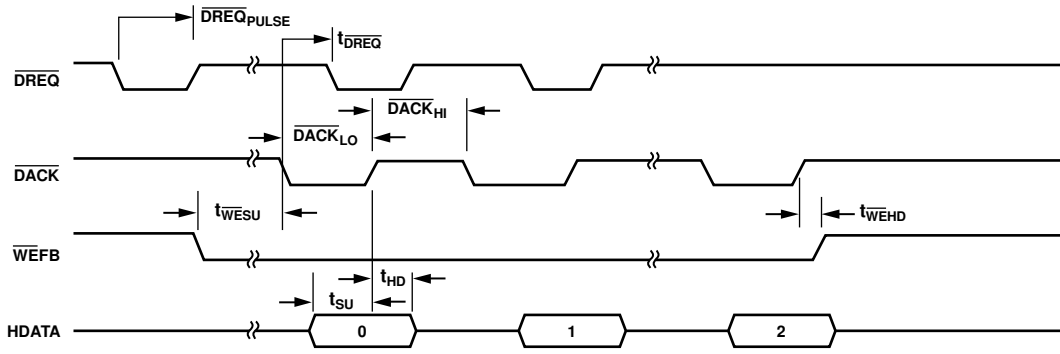

Figure 7. Fly-By DMA Mode—Single Write Cycle (\overline{DREQ} Pulse Width Is Programmable)

04723-015

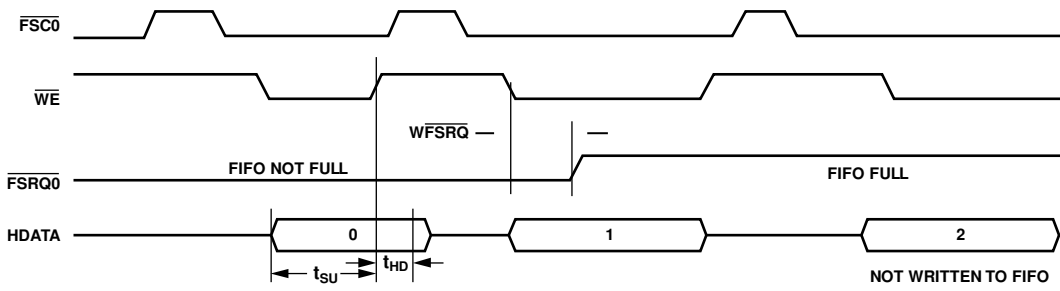

Figure 8. DCS DMA Mode—Single Write Access (Rev. 0.1 and Higher)

04723-016

DREQ/DACK DMA MODE—SINGLE FIFO READ OPERATION

Table 7.

Parameter	Description	Min	Typ	Max	Unit
\overline{DREQ}_{PULSE}	\overline{DREQ} Pulse Width ¹	1		15	JCLK cycles ²
$t_{\overline{DREQ}}$	\overline{DACK} Assert to Subsequent \overline{DREQ} Delay	2.5		$3.5 \times JCLK + 7.5 \text{ ns}$	JCLK cycles
$t_{\overline{RD}SU}$	\overline{RD} to \overline{DACK} Setup	0			ns
$t_{\overline{RD}}$	\overline{DACK} to Data Valid	2.5		11	ns
t_{HD}	Data Hold	1.5			ns
\overline{DACK}_{LO}	\overline{DACK} Assert Pulse Width	2			JCLK cycles
\overline{DACK}_{HI}	\overline{DACK} Deassert Pulse Width	2			JCLK cycles
$t_{\overline{RD}HD}$	\overline{RD} Hold After \overline{DACK} Deassert	0			ns
RDFSQ	\overline{RD} Assert to \overline{FSRQ} Deassert (FIFO Empty)	1.5		$2.5 \times JCLK + 7.5 \text{ ns}$	JCLK cycles
$t_{\overline{DREQ}RTN}$	\overline{DACK} to \overline{DREQ} Deassert ($DR \times PULS = 0$)	2.5		$3.5 \times JCLK + 7.5 \text{ ns}$	JCLK cycles

¹ Applies to assigned DMA channel, if EDMOD0 or EDMOD1[14:11] is programmed to a nonzero value.
² For a definition of JCLK, see the PLL section.

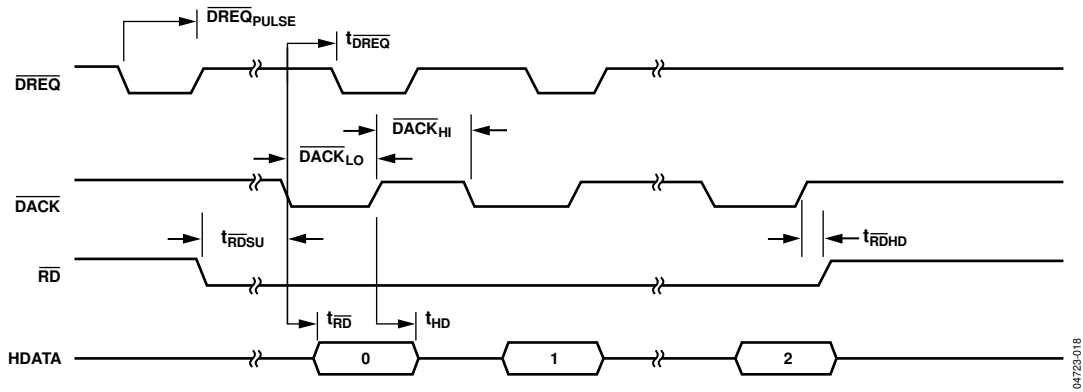

Figure 9. Single Read for $\overline{DREQ}/\overline{DACK}$ DMA Mode for Assigned DMA Channel (EDMOD0/EDMOD1[14:11] Not Programmed to a Value of 0000)

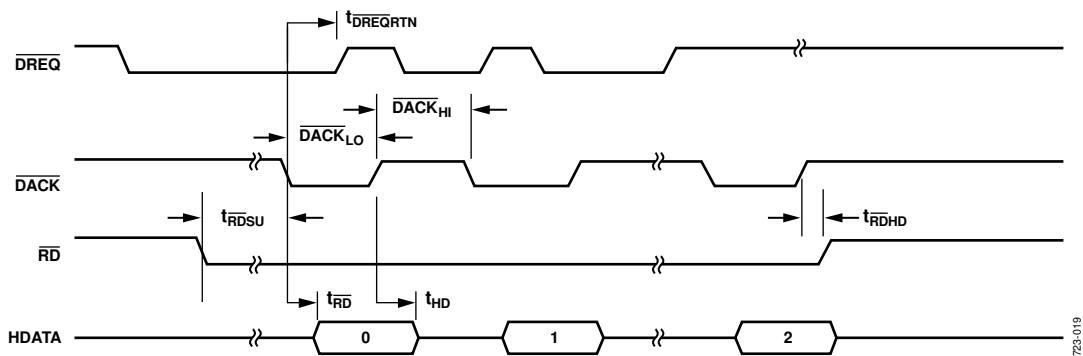

Figure 10. Single Read for $\overline{DREQ}/\overline{DACK}$ DMA Mode for Assigned DMA Channel (EDMOD0/EDMOD1[14:11] Programmed to a Value of 0000)

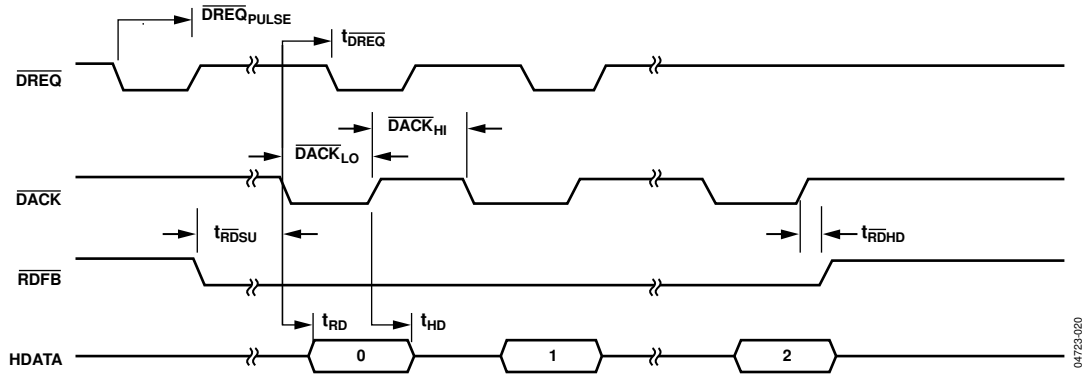

Figure 11. Fly-By DMA Mode—Single Read Cycle
(DREQ Pulse Width Is Programmable)

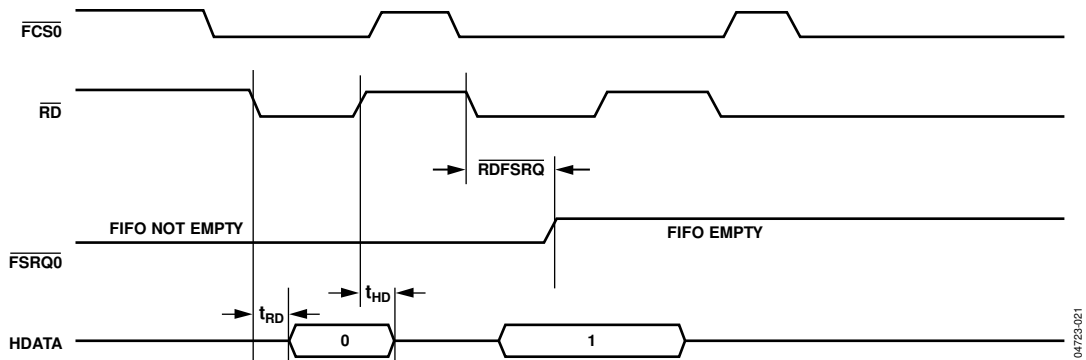

Figure 12. DCS DMA Mode—Single Read Access (Rev. 0.1 and Higher)

EXTERNAL DMA MODE—FIFO WRITE, BURST MODE

Table 8.

Parameter	Description	Min	Typ	Max	Unit
$\overline{\text{DREQ}}_{\text{PULSE}}$	$\overline{\text{DREQ}}$ Pulse Width ¹	1		15	JCLK ² cycles
$t_{\overline{\text{DREQ}}\text{RTN}}$	$\overline{\text{WE}}$ to $\overline{\text{DREQ}}$ Deassert ($\text{DR} \times \text{Pulse} = 0$)	2.5		$3.5 \times \text{JCLK} + 7.5 \text{ ns}$	JCLK cycles
$t_{\overline{\text{DACK}}\text{SU}}$	$\overline{\text{DACK}}$ to $\overline{\text{WE}}$ Setup	0			ns
t_{SU}	Data Setup	2.5			ns
t_{HD}	Data Hold	2			ns
$\overline{\text{WE}}_{\text{LO}}$	$\overline{\text{WE}}$ Assert Pulse Width	1.5			JCLK cycles
$\overline{\text{WE}}_{\text{HI}}$	$\overline{\text{WE}}$ Deassert Pulse Width	1.5			JCLK cycles
$t_{\overline{\text{DREQ}}\text{WAIT}}$	Last Burst Access to Next $\overline{\text{DREQ}}$	2.5		$4.5 \times \text{JCLK} + 7.5 \text{ ns}^3$	JCLK cycles

¹ Applies to assigned DMA channel, if EDMOD0 or EDMOD1[14:11] is programmed to a value that is not 0. Pulse width depends on the value programmed.

² For a definition of JCLK, see the PLL section.

³ If sufficient space is available in FIFO.

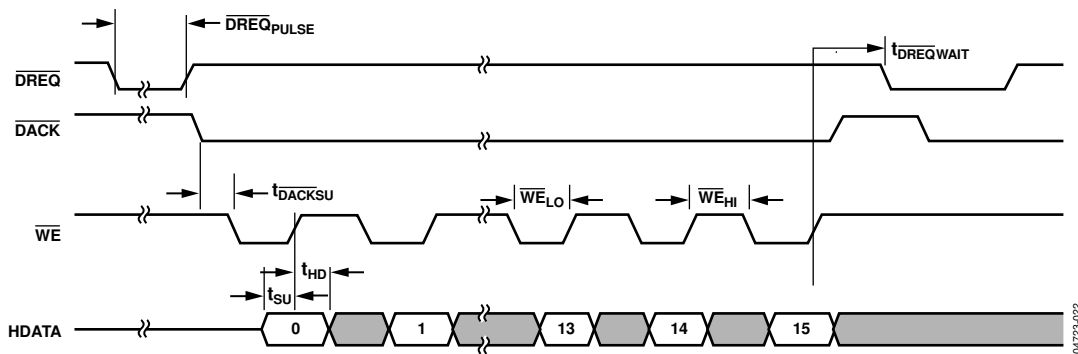

Figure 13. Burst Write Cycle for $\overline{\text{DREQ}}$ /DMA Mode for Assigned DMA Channel (EDMOD0/EDMOD1[14:11] NOT Programmed to a Value of 0000)

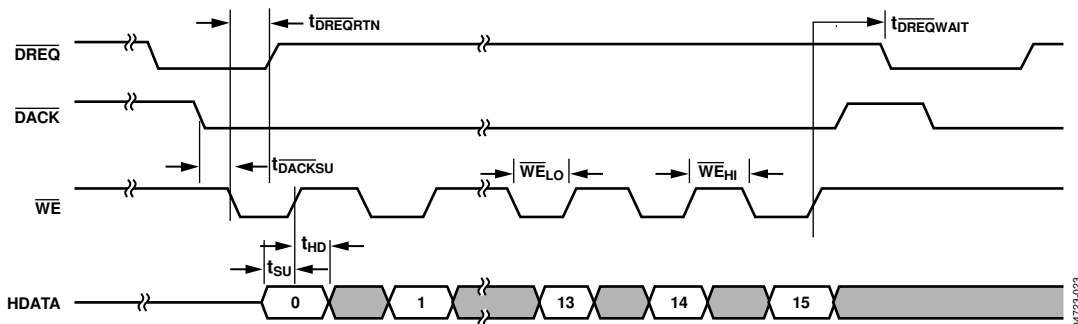

Figure 14. Burst Write Cycle for $\overline{\text{DREQ}}$ /DMA Mode for Assigned DMA Channel (EDMOD0/EDMOD1[14:11] Programmed to a Value of 0000)

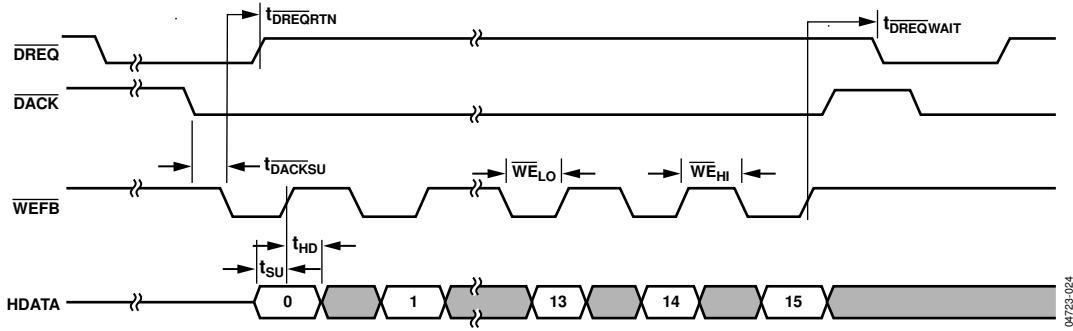

Figure 15. Burst Write Cycle for Fly-By DMA Mode
(DREQ Pulse Width Is Programmable)

EXTERNAL DMA MODE—FIFO READ, BURST MODE

Table 9.

Parameter	Description	Min	Typ	Max	Unit
DREQ _{PULSE}	DREQ Pulse Width ¹	1		15	JCLK cycles ²
t _{DREQRTN}	RD to DREQ Deassert (DR × PULS = 0)	2.5		3.5 × JCLK + 7.5 ns	JCLK cycles
t _{DACKSU}	DACK to RD Setup	0			ns
t _{RD}	RD to Data Valid	2.5		9.7	ns
t _{HD}	Data Hold	2.5			ns
RD _{LO}	RD Assert Pulse Width	1.5			JCLK cycles
RD _{HI}	RD Deassert Pulse Width	1.5			JCLK cycles
t _{DREQWAIT}	Last Burst Access to Next DREQ	2.5		3.5 × JCLK + 7.5 ns ³	JCLK cycles

¹ Applies to assigned DMA channel, if EDMOD0 or EDMOD1[14:11] is programmed to a value that is not 0. Pulse width depends on the value programmed.

² For a definition of JCLK, see the PLL section.

³ If sufficient space is available in FIFO.

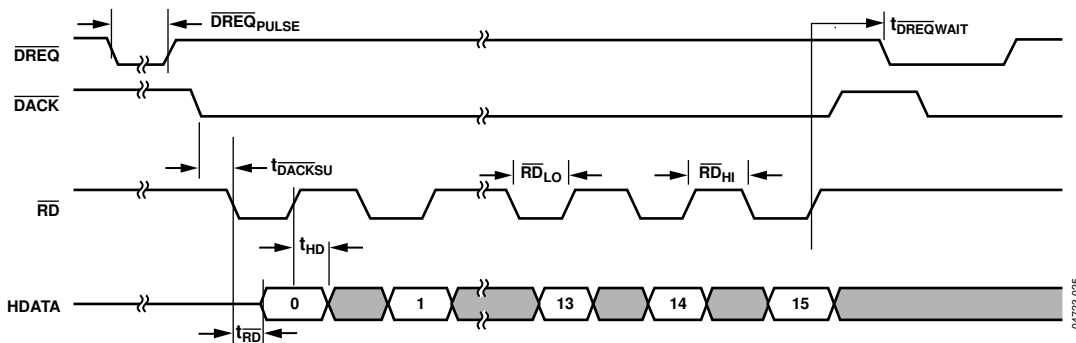

Figure 16. Burst Read Cycle for DREQ/DACK DMA Mode for Assigned DMA Channel
(EMOD0/EDMOD1[14:11] NOT Programmed to a Value of 0)

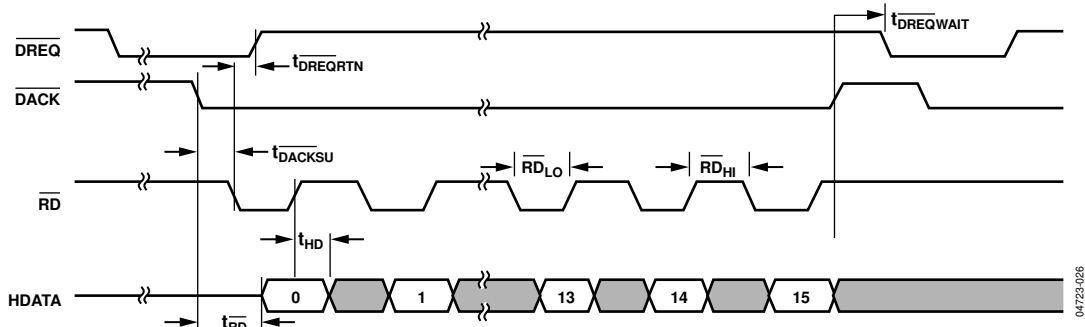

Figure 17. Burst Read Cycle for $\overline{DREQ}/\overline{DACK}$ DMA Mode for Assigned DMA Channel
(EMOD0/EDMOD1[14:11] Programmed to a Value of 0000)

04723-026

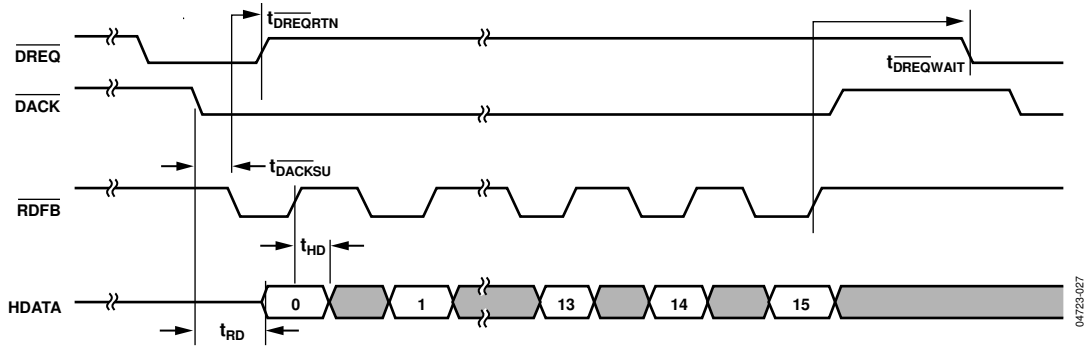

Figure 18. Burst Read Cycle, Fly-By DMA Mode
(DREQ Pulse Width Is Programmable)

04723-027

STREAMING MODE (JDATA)—FIFO READ/WRITE

Table 10.

Parameter	Description	Min	Typ	Max	Unit
JDATA _{TD}	MCLK to JDATA Valid	1.5		2.5 × JCLK + 7.0 ns	JCLK cycles ¹
VALID _{TD}	MCLK to VALID Assert/Deassert	1.5		2.5 × JCLK + .7.0 ns	JCLK cycles
HOLD _{SU}	HOLD Setup to Rising MCLK	3			ns
HOLD _{HD}	HOLD Hold from Rising MCLK	3			ns
JDATA _{SU}	JDATA Setup to Rising MCLK	3			ns
JDATA _{HD}	JDATA Hold from Rising MCLK	3			ns

¹ For a definition of JCLK, see the PLL section.

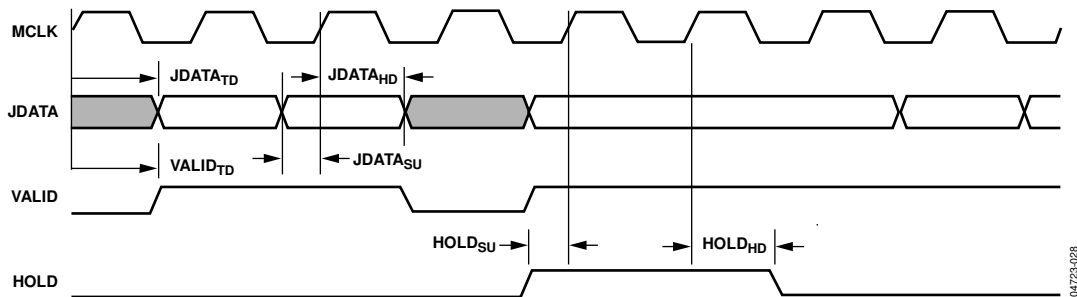

Figure 19. Streaming Mode Timing—Encode Mode JDATA Output

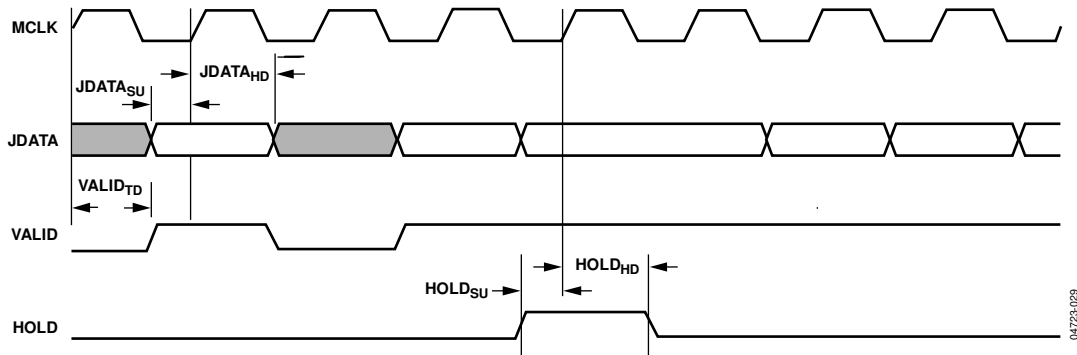

Figure 20. Streaming Mode Timing—Decode Mode JDATA Input

VDATA MODE TIMING

Table 11.

Parameter	Description	Min	Typ	Max	Unit
$VDATA_{TD}$	VCLK to VDATA Valid Delay (VDATA Output)			12	ns
$VDATA_{SU}$	VDATA Setup to Rising VCLK (VDATA Input)	4			ns
$VDATA_{HD}$	VDATA Hold from Rising VCLK (VDATA Input)	4			ns
$HSYNC_{SU}$	HSYNC Setup to Rising VCLK	3			ns
$HSYNC_{HD}$	HSYNC Hold from Rising VCLK	4			ns
$HSYNC_{TD}$	VCLK to HSYNC Valid Delay			12	ns
$VSYNC_{SU}$	VSYNC Setup to Rising VCLK	3			ns
$VSYNC_{HD}$	VSYNC Hold from Rising VCLK	4			ns
$VSYNC_{TD}$	VCLK to VSYNC Valid Delay			12	ns
$FIELD_{SU}$	FIELD Setup to Rising VCLK	4			ns
$FIELD_{HD}$	FIELD Hold from Rising VCLK	3			ns
$FIELD_{TD}$	VCLK to FIELD Valid			12	ns
SYNC DELAY	Decode Data Sync Delay for HD Input with EAV/SAV Codes		7		VCLK cycles
	Decode Data Sync Delay for SD Input with EAV/SAV Codes		9		VCLK cycles
	Decode Data Sync Delay for HVF Input (from First Rising VCLK after HSYNC Low to First Data Sample)		10		VCLK cycles

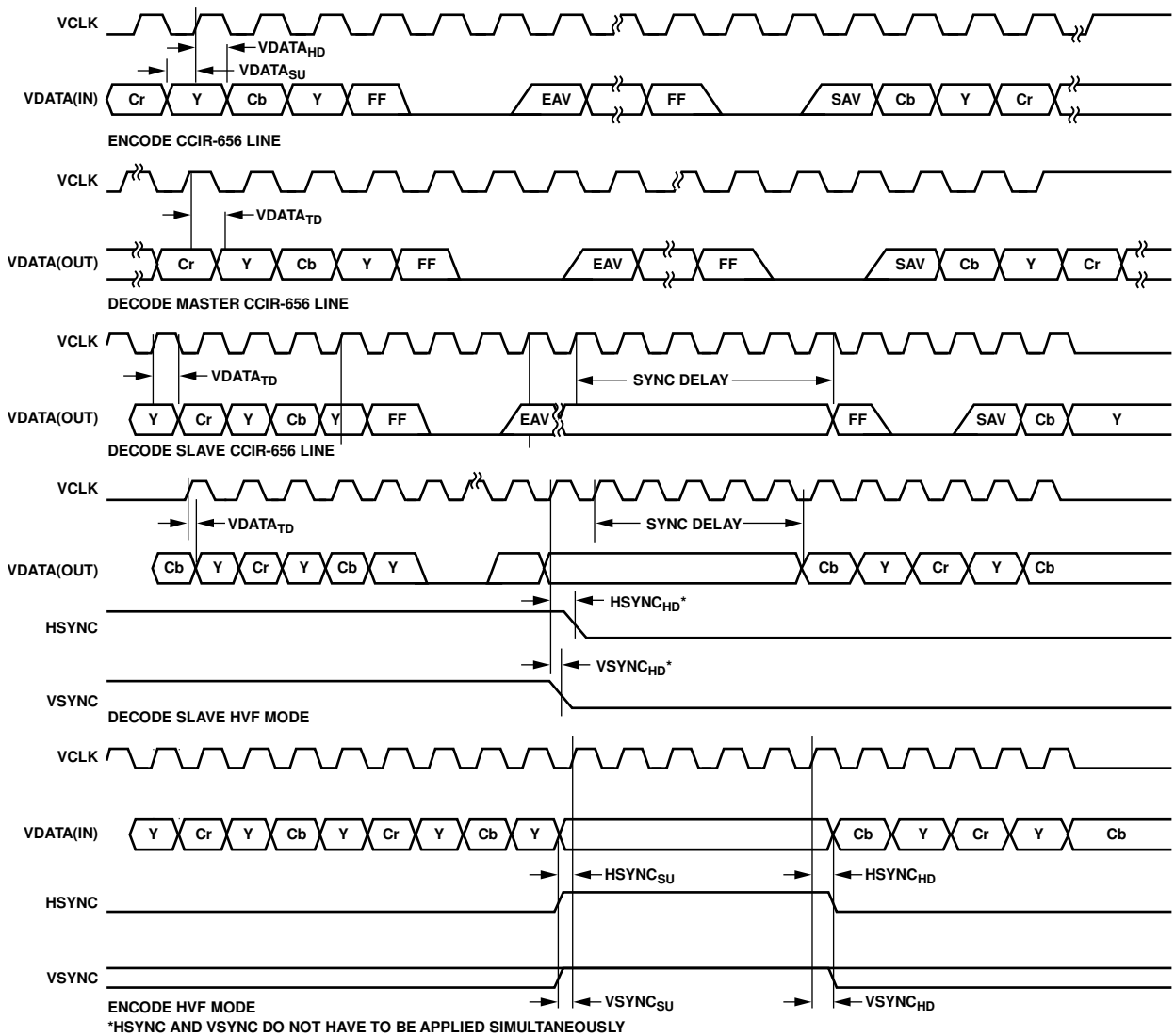

Figure 21. Video Mode Timing

RAW PIXEL MODE TIMING

Table 12.

Parameter	Description	Min	Typ	Max	Unit
VDATA _{TD}	VCLK to PIXELDATA Valid Delay (PIXELDATA Output)			12	ns
VDATA _{SU}	PIXELDATA Setup to Rising VCLK (PIXELDATA Input)	4			ns
VDATA _{HD}	PIXELDATA Hold from Rising VCLK (PIXELDATA Input)	4			ns
VRDY _{TD}	VCLK to VRDY Valid Delay			12	ns
VFRM _{SU}	VFRM Setup to Rising VCLK (VFRAME Input)	3			ns
VFRM _{HD}	VFRM Hold from Rising VCLK (VFRAME Input)	4			ns
VFRM _{TD}	VCLK to VFRM Valid Delay (VFRAME Output)			12	ns
VSTRB _{SU}	VSTRB Setup to Rising VCLK	4			ns
VSTRB _{HD}	VSTRB Hold from Rising VCLK	3			ns

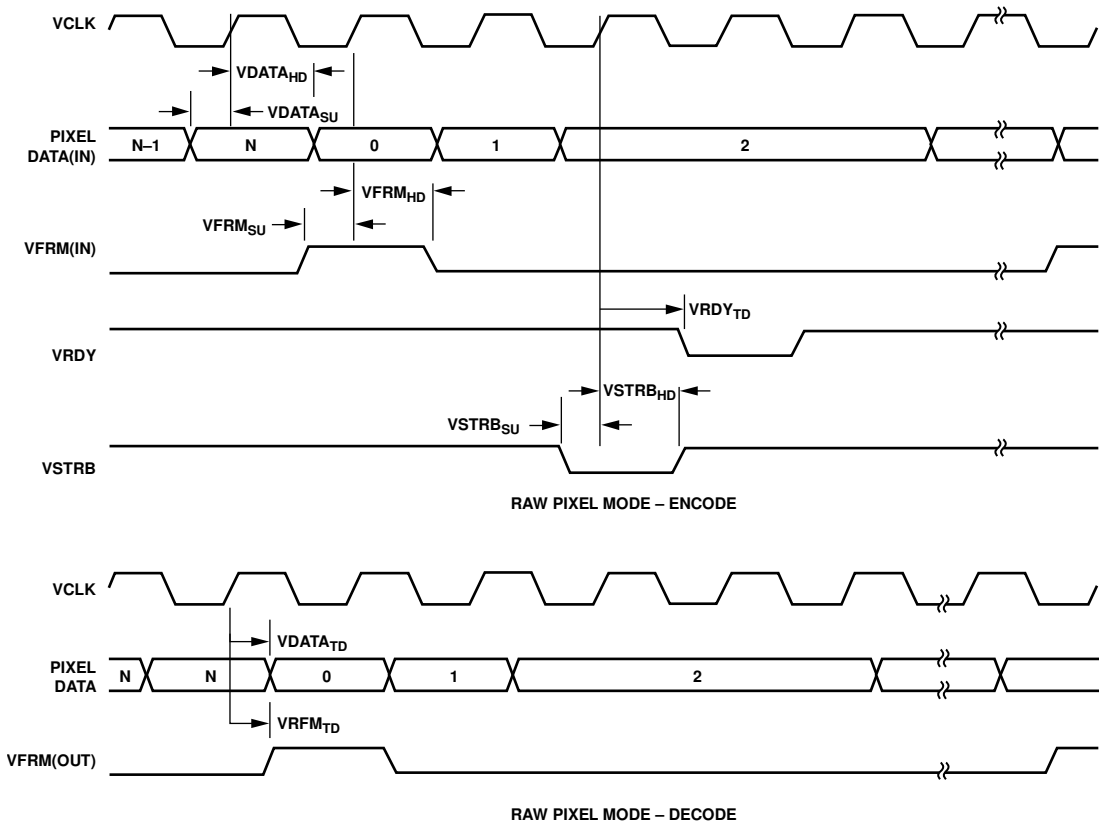

Figure 22. Raw Pixel Mode Timing

ABSOLUTE MAXIMUM RATINGS

Table 13.

Parameter	Rating
VDD (Supply Voltage, Core)	−0.3 V to +1.65 V
IOVDD (Supply Voltage, I/O)	−0.3 V to +IOVDD + 0.3 V
PLLVD (Supply Voltage, PLL)	−0.3 V to +1.65 V
Storage Temperature (T _s) Range	−65°C to 150°C

Stresses above those listed under Absolute Maximum Ratings may cause permanent damage to the device. This is a stress rating only; functional operation of the device at these or any other conditions above those indicated in the operational section of this specification is not implied. Exposure to absolute maximum rating conditions for extended periods may affect device reliability.

THERMAL RESISTANCE

θ_{JA} is specified for the worst-case conditions, that is, a device soldered in a circuit board for surface-mount packages.

Table 14. Thermal Resistance

Package Type	θ_{JA}	θ_{JC}	Unit
ADV202 (144-Lead)	22.5°	3.8°	C/W
ADV202 (121-Lead)	32.8°	7.92°	C/W

ESD CAUTION



ESD (electrostatic discharge) sensitive device. Charged devices and circuit boards can discharge without detection. Although this product features patented or proprietary protection circuitry, damage may occur on devices subjected to high energy ESD. Therefore, proper ESD precautions should be taken to avoid performance degradation or loss of functionality.

PIN BGA ASSIGNMENTS AND FUNCTION DESCRIPTIONS

PIN BGA ASSIGNMENTS

Table 15. Pin BGA Assignments for 121-Lead Package

Pin. No.	Pin Location	Pin Description	Pin. No.	Pin Location	Pin Description
1	A1	DGND	50	E6	DGND
2	A2	HDATA[2]	51	E7	DGND
3	A3	VDD	52	E8	IOVDD
4	A4	DGND	53	E9	VCLK
5	A5	HDATA[0]	54	E10	FIELD
6	A6	HDATA[1]	55	E11	DGND
7	A7	VDATA[1]	56	F1	DGND
8	A8	VDD	57	F2	HDATA[19]_VDATA[15]
9	A9	DGND	58	F3	HDATA[20]
10	A10	VDATA[0]	59	F4	HDATA[21]
11	A11	DGND	60	F5	DGND
12	B1	HDATA[3]	61	F6	DGND
13	B2	HDATA[4]	62	F7	DGND
14	B3	HDATA[5]	63	F8	$\overline{\text{DREQ0}}$
15	B4	HDATA[7]	64	F9	$\overline{\text{DACK0}}$
16	B5	HDATA[8]	65	F10	$\overline{\text{DREQ1}}$
17	B6	IOVDD	66	F11	DGND
18	B7	VDATA[6]	67	G1	DGND
19	B8	VDATA[5]	68	G2	HDATA[22]
20	B9	VDATA[4]	69	G3	HDATA[23]
21	B10	VDATA[2]	70	G4	HDATA[24]_JDATA[0]
22	B11	VDATA[3]	71	G5	DGND
23	C1	DGND	72	G6	DGND
24	C2	HDATA[6]	73	G7	DGND
25	C3	HDATA[9]	74	G8	IOVDD
26	C4	HDATA[10]	75	G9	$\overline{\text{DACK1}}$
27	C5	HDATA[11]	76	G10	$\overline{\text{IRQ}}$
28	C6	IOVDD	77	G11	DGND
29	C7	VDATA[9]	78	H1	HDATA[28]_JDATA[4]
30	C8	IOVDD	79	H2	HDATA[27]_JDATA[3]
31	C9	VDATA[8]	80	H3	HDATA[26]_JDATA[2]
32	C10	VDATA[7]	81	H4	HDATA[25]_JDATA[1]
33	C11	DGND	82	H5	IOVDD
34	D1	HDATA[12]	83	H6	DGND
35	D2	HDATA[13]	84	H7	VDD
36	D3	HDATA[14]	85	H8	$\overline{\text{ACK}}$
37	D4	HDATA[15]	86	H9	$\overline{\text{RD}}$
38	D5	IOVDD	87	H10	ADDR[1]
39	D6	DGND	88	H11	ADDR[3]
40	D7	VDD	89	J1	DGND
41	D8	VSYN	90	J2	HDATA[31]_JDATA[7]
42	D9	HSYN	91	J3	HDATA[30]_JDATA[6]
43	D10	VDATA[10]	92	J4	HDATA[29]_JDATA[5]
44	D11	VDATA[11]	93	J5	IOVDD
45	E1	DGND	94	J6	TEST1
46	E2	HDATA[18]_VDATA[14]	95	J7	$\overline{\text{WE}}$
47	E3	HDATA[17]_VDATA[13]	96	J8	$\overline{\text{CS}}$
48	E4	HDATA[16]_VDATA[12]	97	J9	ADDR[0]
49	E5	DGND			

Pin No.	Pin Location	Pin Description
98	J10	TEST3
99	J11	DGND
100	K1	SCOMM[4]
101	K2	SCOMM[3]
102	K3	SCOMM[0]
103	K4	SCOMM[1]
104	K5	IOVDD
105	K6	IOVDD
106	K7	IOVDD
107	K8	ADDR[2]
108	K9	TEST2
109	K10	TEST5

Pin No.	Pin Location	Pin Description
110	K11	DGND
111	L1	DGND
112	L2	SCOMM[7]
113	L3	SCOMM[6]
114	L4	SCOMM[5]
115	L5	SCOMM[2]
116	L6	TEST4
117	L7	RESET
118	L8	DGND
119	L9	MCLK
120	L10	PLLVD
121	L11	DGND

Table 16. Pin BGA Assignments for 144-Lead Package

Pin No.	Pin Location	Pin Description
1	A1	DGND
2	A2	HDATA[2]
3	A3	HDATA[1]
4	A4	HDATA[0]
5	A5	DGND
6	A6	DGND
7	A7	DGND
8	A8	DGND
9	A9	VDATA[2]
10	A10	VDATA[1]
11	A11	VDATA[0]
12	A12	DGND
13	B1	HDATA[5]
14	B2	HDATA[4]
15	B3	HDATA[3]
16	B4	IOVDD
17	B5	DGND
18	B6	VDD
19	B7	VDD
20	B8	DGND
21	B9	IOVDD
22	B10	VDATA[5]
23	B11	VDATA[4]
24	B12	VDATA[3]
25	C1	HDATA[8]
26	C2	HDATA[7]
27	C3	HDATA[6]
28	C4	IOVDD
29	C5	DGND
30	C6	VDD
31	C7	VDD
32	C8	DGND
33	C9	IOVDD
34	C10	VDATA[8]
35	C11	VDATA[7]
36	C12	VDATA[6]
37	D1	HDATA[11]

Pin No.	Pin Location	Pin Description
38	D2	HDATA[10]
39	D3	HDATA[9]
40	D4	IOVDD
41	D5	DGND
42	D6	VDD
43	D7	VDD
44	D8	DGND
45	D9	IOVDD
46	D10	VDATA[11]
47	D11	VDATA[10]
48	D12	VDATA[9]
49	E1	HDATA[14]
50	E2	HDATA[13]
51	E3	HDATA[12]
52	E4	DGND
53	E5	DGND
54	E6	DGND
55	E7	DGND
56	E8	DGND
57	E9	FIELD
58	E10	VS
59	E11	HS
60	E12	VCLK
61	F1	HDATA[18]_VDATA[14]
62	F2	HDATA[17]_VDATA[13]
63	F3	HDATA[16]_VDATA[12]
64	F4	HDATA[15]
65	F5	DGND
66	F6	DGND
67	F7	DGND
68	F8	DGND
69	F9	DACK1
70	F10	DREQ1
71	F11	DACK0
72	F12	DREQ0
73	G1	HDATA[22]
74	G2	HDATA[21]

Pin No.	Pin Location	Pin Description
75	G3	HDATA[20]
76	G4	HDATA[19]_VDATA[15]
77	G5	DGND
78	G6	DGND
79	G7	DGND
80	G8	DGND
81	G9	DGND
82	G10	$\overline{\text{IRQ}}$
83	G11	$\overline{\text{ACK}}$
84	G12	$\overline{\text{RD}}$
85	H1	HDATA[26]_JDATA[2]
86	H2	HDATA[25]_JDATA[1]
87	H3	HDATA[24]_JDATA[0]
88	H4	HDATA[23]
89	H5	DGND
90	H6	DGND
91	H7	DGND
92	H8	DGND
93	H9	DGND
94	H10	$\overline{\text{WR}}$
95	H11	$\overline{\text{CS}}$
96	H12	ADDR[0]
97	J1	HDATA[30]_JDATA[6]
98	J2	HDATA[29]_JDATA[5]
99	J3	HDATA[28]_JDATA[4]
100	J4	HDATA[27]_JDATA[3]
101	J5	DGND
102	J6	VDD
103	J7	VDD
104	J8	DGND
105	J9	DGND
106	J10	ADDR[1]
107	J11	ADDR[2]
108	J12	ADDR[3]
109	K1	SCOMM[1]

Pin No.	Pin Location	Pin Description
110	K2	SCOMM[0]
111	K3	HDATA[31]_JDATA[7]
112	K4	IOVDD
113	K5	DGND
114	K6	VDD
115	K7	VDD
116	K8	DGND
117	K9	IOVDD
118	K10	TEST3
119	K11	TEST2
120	K12	TEST1
121	L1	SCOMM[4]
122	L2	SCOMM[3]
123	L3	SCOMM[2]
124	L4	IOVDD
125	L5	DGND
126	L6	VDD
127	L7	VDD
128	L8	DGND
129	L9	IOVDD
130	L10	TEST5
131	L11	$\overline{\text{RESET}}$
132	L12	MCLK
133	M1	DGND
134	M2	SCOMM[7]
135	M3	SCOMM[6]
136	M4	SCOMM[5]
137	M5	DGND
138	M6	DGND
139	M7	DGND
140	M8	DGND
141	M9	TEST4
142	M10	PLLVD
143	M11	DGND
144	M12	DGND

PIN FUNCTION DESCRIPTIONS

Table 17.

Mnemonic	Pins Used	121-Lead Package	144-Lead Package	I/O	Description
MCLK	1	L9	L12	I	System Input Clock. For details, see the PLL section. Maximum input frequency on MCLK is 74.25 MHz.
$\overline{\text{RESET}}$	1	L7	L11	I	Reset. Causes the ADV202 to immediately reset. $\overline{\text{CS}}$, $\overline{\text{RD}}$, $\overline{\text{WE}}$, $\overline{\text{DACK0}}$, $\overline{\text{DACK1}}$, $\overline{\text{DREQ0}}$, and $\overline{\text{DREQ1}}$ must be held high when a $\overline{\text{RESET}}$ is applied.
HDATA[15:0]	16	D4 to D1, C5 to C3, B5, B4, C2, B3 to B1, A2, A6 to A5	F4, E1 to E3, D1 to D3, C1 to C3, B1 to B3, A2, A3, A4	I/O	Host Data Bus. With HDATA[23:16], [27:24], [31:28], these pins make up the 32-bit wide host data bus. The async host interface is interfaced together with ADDR[3:0], $\overline{\text{CS}}$, $\overline{\text{WE}}$, $\overline{\text{RD}}$, and $\overline{\text{ACK}}$. Unused HDATA pins should be pulled down via a 10 k Ω resistor.
ADDR[3:0]	4	H11, K8, H10, J9	J12, J11, J10, H12	I	Address Bus for the Host Interface.
$\overline{\text{CS}}$	1	J8	H11	I	Chip Select. This signal is used to qualify addressed read and write access to the ADV202 using the host interface.
$\overline{\text{WE}}$	1	J7	H10	I	Write Enable Used with the Host Interface.
$\overline{\text{RDFB}}$					Read Enable When Fly-By DMA Is Enabled. Note: Simultaneous assertion of $\overline{\text{WE}}$ and $\overline{\text{DACK}}$ low activates the HDATA bus, even if the DMA channels are disabled.
$\overline{\text{RD}}$	1	H9	G12	I	Read Enable. Used with the host interface.
$\overline{\text{WEFB}}$					Write Enable When Fly-By DMA Is Enabled. Note: Simultaneous assertion of $\overline{\text{RD}}$ and $\overline{\text{DACK}}$ low activates the HDATA bus, even if the DMA channels are disabled.
$\overline{\text{ACK}}$	1	H8	G11	O	Acknowledge. Used for direct register accesses. This signal indicates that the last register access was successful. Note: Due to synchronization issues, control and status register accesses can incur an additional delay, so the host software should wait for acknowledgment from the ADV202. Accesses to the FIFOs (external DMA modes), on the other hand, are guaranteed to occur immediately, if space is available, and should not wait for $\overline{\text{ACK}}$, if the timing constraints are observed. If $\overline{\text{ACK}}$ is shared with more than one device, $\overline{\text{ACK}}$ should be connected to a pull-up resistor (10 k Ω) and the PLL_HI register, Bit 4, must be set to 1.
$\overline{\text{IRQ}}$	1	G10	G10	O	Interrupt. This pin indicates that the ADV202 requires the attention of the host processor. This pin can be programmed to indicate the status of the internal interrupt conditions within the ADV202. The interrupt sources are enabled via bits in Register EIRQIE.
$\overline{\text{DREQ0}}$	1	F8	F12	O	Data Request for External DMA Interface. Indicates that the ADV202 is ready to send/receive data to/from the FIFO assigned to DMA Channel 0.
$\overline{\text{FSRQ0}}$				O	Used in DCS-DMA Mode. Service request from the FIFO assigned to Channel 0 (asynchronous mode).
$\overline{\text{VALID}}$				O	Valid Indication for JDATA Input/Output Stream. Polarity of this pin is programmable in the EDMOD0 register. $\overline{\text{VALID}}$ is always an output.
CFG[1]				I	Boot Mode Configuration. This pin is read on reset to determine the boot configuration of the on-board processor. The pin should be tied to IOVDD or DGND through a 10 k Ω resistor.
$\overline{\text{DACK0}}$	1	F9	F11	I	Data Acknowledge for External DMA Interface. Signal from the host CPU, which indicates that the data transfer request ($\overline{\text{DREQ0}}$) has been acknowledged and data transfer can proceed. This pin must be held high at all times if the DMA interface is not used, even if the DMA channels are disabled.

Mnemonic	Pins Used	121-Lead Package	144-Lead Package	I/O	Description
HOLD				I	External Hold Indication for JDATA Input/Output Stream. Polarity is programmable in the EDMOD0 register. This pin is always an input.
$\overline{\text{FCS0}}$				I	Used in DCS-DMA Mode. Chip select for the FIFO assigned to Channel 0 (asynchronous mode).
$\overline{\text{DREQ1}}$	1	F10	F10	O	Data Request for External DMA Interface. Indicates that the ADV202 is ready to send/receive data to/from the FIFO assigned to DMA Channel 1.
$\overline{\text{FSRQ1}}$				O	Used in DCS-DMA Mode. Service request from the FIFO assigned to Channel 1 (asynchronous mode).
CFG[2]				I	Boot Mode Configuration. This pin is read on reset to determine the boot configuration of the on-board processor. The pin should be tied to IOVDD or DGND through a 10 k Ω resistor.
$\overline{\text{DACK1}}$	1	G9	F9	I	Data Acknowledge for External DMA Interface. Signal from the host CPU, which indicates that the data transfer request ($\overline{\text{DREQ1}}$) has been acknowledged and data transfer can proceed. This pin must be held high at all times unless a DMA or JDATA access is occurring. This pin must be held high at all times if the DMA interface is not used, even if the DMA channels are disabled.
$\overline{\text{FCS1}}$				I	Used in DCS-DMA Mode. Chip select for the FIFO assigned to Channel 1 (asynchronous mode).
HDATA[31:28]	4	J2 to J4, H1	K3, J1 to J3	I/O	Host Expansion Bus.
JDATA[7:4]				I/O	JDATA Bus (JDATA Mode).
HDATA[27:24]	4	H2 to H4, G4	J4, H1 to H3	I/O	Host Expansion Bus.
JDATA[3:0]				I/O	JDATA Bus (JDATA Mode).
HDATA[23:16]	8	G3, G2, F4, F3, F2 E2, E3, E4	H4, G1 to G4, F1 to F3	I/O	Host Expansion Bus.
SCOMM[7]	8	L2	M2	I/O	When not used, this pin should be tied low via a 10 k Ω resistor.
SCOMM[6]		L3	M3	I/O	When not used, this pin should be tied low via a 10 k Ω resistor.
SCOMM[5]		L4	M4	I/O	This pin must be used in multiple chip mode to align the outputs of two or more ADV202s. For details, see the Applications section and AN-796 ADV202 Multichip Application application note. When not used, this pin should be tied low via a 10 k Ω resistor.
SCOMM[4]		K1	L1	O	LCODE Output in Encode Mode. When LCODE is enabled, the output on this pin indicates on a high transition that the last data-word for a field has been read from the FIFO. For an 8-bit interface, such as JDATA, LCODE is asserted for four consecutive bytes and is enabled by default.
SCOMM[3]		K2	L2	O	This pin should be tied low via a 10 k Ω resistor.
SCOMM[2]		L5	L3	O	This pin should be tied low via a 10 k Ω resistor.
SCOMM[1]		K4	K1	I	This pin should be tied low via a 10 k Ω resistor.
SCOMM[0]		K3	K2	O	This pin should be tied low via a 10 k Ω resistor.
VCLK	1	E9	E12	I	Video Data Clock. Must be supplied if video data is input/output on the VDATA bus.
VDATA[11:0]	12	D11, D10, C7, C9, C10, B7, B8, B9, B11, B10, A7, A10	D10 to D12, C10 to C12, B10 to B12, A9 to A11	I/O	Video Data. Unused pins should be pulled down via a 10 k Ω resistor.
VSYNC	1	D8	E10	I/O	Vertical Sync for Video Mode.
VFRM					Raw Pixel Mode Framing Signal. Indicates first sample of a tile when asserted high.
HSYNC	1	D9	E11	I/O	Horizontal Sync for Video Mode.
VRDY				O	Raw Pixel Mode Ready Signal.

Mnemonic	Pins Used	121-Lead Package	144-Lead Package	I/O	Description
FIELD	1	E10	E9	I/O	Field Sync for Video Mode.
VSTRB				I	Raw Pixel Mode Transfer Strobe.
TEST1	1	J6	K12	I	This pin should be connected to ground via a pull-down resistor.
TEST2	1	K9	K11	I	This pin should be connected to ground via a pull-down resistor.
TEST3	1	J10	K10	I	This pin should be connected to ground via a pull-down resistor.
TEST4	1	L6	M9	I	This pin should be connected to ground via a pull-down resistor.
TEST5	1	K10	L10	O	No Connect.
VDD		A3, A8, D7, H7	B6, B7, C6, C7, D6, D7, J6, J7, K6, K7, L6, L7	V	Positive Supply for Core.
DGND		A1, A11, A4, A9, C1, C11, D6, E1, E5 to E7, E11, F1, F5 to F7, F11, G1, G5 to G7, G11, H6, J1, J11, K11, L1, L8, L11	A1, A5 to A8, A12, B5, B8, C5, C8, D5, D8, E4 to E8, F5 to F8, G5 to G9, H5 to H9, J5, J8 to J9, K5, K8, L5, L8, M1, M5 to M8, M11, M12	GND	Ground.
PLLVD	1	L10	M10	V	Positive Supply for PLL.
IOVDD		B6, C6, C8, D5, E8, G8, H5, J5, K5, K6, K7	B4, B9, C4, C9, D4, D9, K4, K9, L4, L9	V	Positive Supply for I/O.

THEORY OF OPERATION

The input video or pixel data is passed on to the ADV202's pixel interface, where samples are de-interleaved and passed on to the wavelet engine, which decomposes each tile or frame into subbands using the 5/3 or 9/7 filters. The resulting wavelet coefficients are then written to internal memory. Next, the entropy codecs code the image data so it conforms to the JPEG2000 standard. An internal DMA provides high bandwidth memory-to-memory transfers, as well as high performance transfers between functional blocks and memory.

WAVELET ENGINE

The ADV202 provides a dedicated wavelet transform processor based on Analog Devices' proven and patented SURF technology. This processor can perform up to six wavelet decomposition levels on a tile. In encode mode, the wavelet transform processor takes in uncompressed samples, performs the wavelet transform and quantization, and writes the wavelet coefficients in all frequency subbands to internal memory. Each of these subbands is then further broken down into code blocks. The code-block dimensions can be user-defined and are used by the wavelet transform processor to organize the wavelet coefficients into code blocks when writing to internal memory. Each completed code block is then entropy coded by one of the entropy codecs.

In decode mode, wavelet coefficients are read from internal memory and recomposed into uncompressed samples.

ENTROPY CODECS

The entropy codec block performs context modeling and arithmetic coding on a code block of the wavelet coefficients. Additionally, this block performs the distortion metric calculations during compression that are required for optimal rate and distortion performance. Because the entropy coding process is the most computationally intensive operation in the JPEG2000 compression process, three dedicated hardware entropy codecs are provided on the ADV202.

EMBEDDED PROCESSOR SYSTEM

The ADV202 incorporates an embedded 32-bit RISC processor. This processor is used for configuration, control, and management of the dedicated hardware functions, as well as for parsing and generating the JPEG2000 code stream. The processor system includes memory for both program and data memory, an interrupt controller, standard bus interfaces, and other hardware functions such as timers and counters.

MEMORY SYSTEM

The memory system's main function is to manage wavelet coefficient data, interim code-block attribute data, and temporary work space for creating, parsing, and storing the JPEG2000 code stream. The memory system can also be used for program and data memory for the embedded processor.

INTERNAL DMA ENGINE

The internal DMA engine provides high bandwidth memory-to-memory transfers, as well as high performance transfers between memory and functional blocks. This function is critical for high speed generation and parsing the code stream.

ADV202 INTERFACE

There are several possible modes to interface to the ADV202 using the VDATA bus and the HDATA bus or the HDATA bus alone.

VIDEO INTERFACE (VDATA BUS)

The video interface can be used in applications in which uncompressed pixel data is on a separate bus from compressed data. For example, it is possible to use the VDATA bus to input uncompressed video while using the HDATA bus to output the compressed data. This interface is ideal for applications requiring very high throughput such as live video capture.

Optionally, the ADV202 can compress ITU.R-BT656 resolution video on a field-by-field basis or on a two-fields-combined basis, which yields significantly more efficient compression performance. Additionally, high definition digital video such as SMPTE274M (1080i) is supported using two or more ADV202 devices.

The video interface can support video data or still image data input/output, 8-, 10-, and 12-bit single or multiplexed components. The VDATA interface supports digital video in YCbCr format or single component format. YCbCr data must be in 4:2:2 format.

Video data can be input/output in several different modes on the VDATA bus, as described in Table 18. In all these modes, the pixel clock must be input on the VCLK pin.

Table 18. Video Input/Output Modes

Mode	Description
EAV/SAV	Accepts video with embedded EAV/SAV codes, where the YCbCr data is interleaved onto a single bus.
HVF	Accepts video data accompanied with separate H, V, and F signals where YCbCr data is interleaved onto a single bus.
Raw Video	Used for still picture data and nonstandard video. VFRM, VSTRB, and VRDY are used to program the dimensions of the image.

HOST INTERFACE (HDATA BUS)

The ADV202 can connect directly to a wide variety of host processors and ASICs using an asynchronous SRAM-style interface, DMA accesses, or streaming mode (JDATA) interface. The ADV202 supports 16- and 32-bit buses for control and 8-, 16-, and 32-bit buses for data transfer.

The control and data channel bus widths can be specified independently, which allows the ADV202 to support applications that require control and data buses of different widths.

The host interface is used for configuration, control, and status functions, as well as for transferring compressed data streams. It can be used for uncompressed data transfers in certain modes. The host interface can be shared by as many as four concurrent data streams in addition to control and status communications. The data streams are

- Uncompressed tile data (for example, still image data)
- Fully encoded JPEG2000 code stream (or unpackaged code blocks)
- Code-block attributes

The ADV202 uses big endian byte alignment for 16- and 32-bit transfers. All data is left-justified (MSB).

Pixel Input on the Host Interface

Pixel input on the host interface supports 8-, 10-, 12-, 14-, and 16-bit raw pixel data formats. It can be used for pixel (still image) input/output or compressed video output. Because there are no timing codes or sync signals associated with the input data on the host interface, dimension registers and internal counters are used and must be programmed to indicate the start and end of the frame. See the [technical note on using HIPI mode](#) for details on how to use the ADV202 in this mode.

Host Bus Configuration

For maximum flexibility, the host interface provides several configurations to meet particular system requirements. The default bus mode uses the same pins to transfer control, status, and data to and from the ADV202. In this mode, the ADV202 can support 16- and 32-bit control transfers and 8-, 16-, and 32-bit data transfers. The size of these buses can be selected independently, allowing, for example, a 16-bit microcontroller to configure and control the ADV202 while still providing 32-bit data transfers to an ASIC or external memory system.

DIRECT AND INDIRECT REGISTERS

To minimize pin count and cost, the number of address pins has been limited to four, which yields a total direct address space of 16 locations. These locations are most commonly used by the external controller and are, therefore, accessible directly. All other registers in the ADV202 can be accessed indirectly through the IADDR and IDATA registers.

CONTROL ACCESS REGISTERS

With the exception of the indirect address and data registers (IADDR and IDATA), all control/status registers in the ADV202 are 16 bits wide and are half-word (16-bit) addressable only. When 32-bit host mode is enabled, the upper 16 bits of the HDATA bus are ignored on writes and return all 0s on reads of 16-bit registers.

PIN CONFIGURATION AND BUS SIZES/MODES

The ADV202 provides a wide variety of control and data configurations, which allows it to be used in many applications with little or no glue logic. The following modes are configured using the BUSMODE register. In the following descriptions, *host* refers to normal addressed accesses ($\overline{CS}/\overline{RD}/\overline{WR}/\overline{ADDR}$) and *data* refers to external DMA accesses ($\overline{DREQ}/\overline{DACK}$).

32-Bit Host/32-Bit Data

In this mode, the HDATA[31:0] pins provide full 32-bit wide data accesses to PIXEL, CODE, and ATTR FIFOs. The expanded video interface (VDATA) is not available in this mode.

16-Bit Host/32-Bit Data

This mode allows a 16-bit host to configure and communicate with the ADV202 while still allowing 32-bit accesses to the PIXEL, CODE, and ATTR FIFOs using the external DMA capability.

All addressed host accesses are 16 bits and, therefore, use only the HDATA[15:0] pins. The HDATA[31:16] pins provide the additional 16 bits necessary to support the 32-bit external DMA transfers to and from the FIFOs only. The expanded video interface (VDATA) is not available in this mode.

16-Bit Host/16-Bit Data

This mode uses 16-bit transfers, if used for host or external DMA data transfers. This mode allows for the use of the extended pixel interface modes.

16-Bit Host/8-Bit Data (JDATA Bus Mode)

This mode provides separate data input/output and host control interface pins. Host control accesses are 16 bits and use HDATA[15:0], while the dedicated data bus uses JDATA[7:0].

JDATA uses a valid/hold synchronous transfer protocol. The direction of the JDATA bus is determined by the mode of the ADV202. If the ADV202 is encoding (compression), JDATA[7:0] is an output. If the ADV202 is decoding (decompression), JDATA[7:0] is an input. Host control accesses remain asynchronous (also refer to the JDATA Mode section).

STAGE REGISTER

Because the ADV202 contains both 16-bit and 32-bit registers and its internal memory is mapped as 32-bit data, a mechanism has been provided to allow 16-bit hosts to access these registers and memory locations using the stage register (STAGE).

STAGE is accessed as a 16-bit register using HDATA[15:0]. Prior to writing to the desired register, the stage register must be written with the upper (most significant) half-word.

When the host subsequently writes the lower half-word to the desired control register, HDATA is combined with the previously staged value to create the required 32-bit value that is written. When a register is read, the upper (most significant) half-word is returned immediately on HDATA and the lower half-word can be retrieved by reading the stage register on a subsequent access. For details on using the stage register, see the [ADV202 User's Guide](#).

Note that the stage register does not apply to the three data channels (PIXEL, CODE, and ATTR). These channels are always accessed at the specified data width and do not require the use of the stage register.

JDATA MODE

JDATA mode is typically used only when the dedicated video interface (VDATA) is also enabled. This mode allows code stream data (compressed data compliant with JPEG2000) to be input or output on a single dedicated 8-bit bus (JDATA[7:0]). The bus is always an output during compression operations and is an input during decompression.

A 2-pin handshake is used to transfer data over this synchronous interface. VALID is used to indicate that the ADV202 is ready to provide or accept data and is always an output. HOLD is always an input and is asserted by the host if it cannot accept/provide data. For example, JDATA mode allows real-time applications, in which pixel data is input over the VDATA bus while the compressed data stream is output over the JDATA bus.

EXTERNAL DMA ENGINE

The external DMA interface is provided to enable high bandwidth data I/O between an external DMA controller and the ADV202 data FIFOs. Two independent DMA channels can each be assigned to any one of the three data stream FIFOs (PIXEL, CODE, or ATTR).

The controller supports asynchronous DMA using a data-request/data-acknowledge ($\overline{DREQ}/\overline{DACK}$) protocol in either single or burst access modes. Additional functionality is provided for single address compatibility (fly-by) and dedicated chip select (DCS) modes.

INTERNAL REGISTERS

This section describes the internal registers of the ADV202.

DIRECT REGISTERS

The ADV202 has 16 direct registers, as listed in Table 19.

The direct registers are accessed over the ADDR[3:0], HDATA[31:0], CS, RD, WR, and ACK pins.

The host must first initialize the direct registers before any application-specific operation can be implemented.

For additional information on accessing and configuring these registers, see the [ADV202 User's Guide](#).

Table 19. Direct Registers

Address	Name	Description
0x00	PIXEL	Pixel FIFO Access Register
0x01	CODE	Compressed Code Stream Access Register
0x02	ATTR	Attribute FIFO Access Register
0x03	Reserved	Reserved
0x04	CMDSTA	Command Stack
0x05	EIRQIE	External Interrupt Enabled
0x06	EIRQFLG	External Interrupt Flags
0x07	SWFLAG	Software Flag Register
0x08	BUSMODE	Bus Mode Configuration Register
0x09	MMODE	Miscellaneous Mode Register
0x0A	STAGE	Staging Register
0x0B	IADDR	Indirect Address Register
0x0C	IDATA	Indirect Data Register
0x0D	BOOT	Boot Mode Register
0x0E	PLL_HI	PLL Control Register—High Byte
0x0F	PLL_LO	PLL Control Register—Low Byte

INDIRECT REGISTERS

In certain modes, such as custom-specific input format or HIPI mode, indirect registers must be accessed by the user through the use of the IADDR and IDATA registers. The indirect register address space starts at Internal Address 0xFFFF0000.

Both 32-bit and 16-bit hosts can access the indirect registers. 32-bit hosts use the IADDR and IDATA registers, while the 16-bit hosts use IADDR, IDATA, and the stage register.

For additional information on accessing and configuring these registers, see the [ADV202 User's Guide](#).

Table 20. Indirect Registers

Address	Name	Description
0xFFFF0400	PMODE1	Pixel/Video Format
0xFFFF0404	COMP_CNT_STATUS	Horizontal Count
0xFFFF0408	LINE_CNT_STATUS	Vertical Count
0xFFFF040C	XTOT	Total Samples per Line
0xFFFF0410	YTOT	Total Lines per Frame
0xFFFF0414	F0_START	Start Line of Field 0 [F0]
0xFFFF0418	F1_START	Start Line of Field 1 [F1]
0xFFFF041C	V0_START	Start of Active Video Field 0 [F0]
0xFFFF0420	V1_START	Start of Active Video Field 1 [F1]
0xFFFF0424	V0_END	End of Active Video Field 0 [F0]
0xFFFF0428	V1_END	End of Active Video Field 1 [F1]
0xFFFF042C	PIXEL_START	Horizontal Start of Active Video
0xFFFF0430	PIXEL_END	Horizontal End of Active Video
0xFFFF0440	MS_CNT_DEL	Master/Slave Delay
0xFFFF0444	Reserved	Reserved
0xFFFF0448	PMODE2	Pixel Mode 2
0xFFFF044C	VMODE	Video Mode
0xFFFF1408	EDMOD0	External DMA Mode Register 0
0xFFFF140C	EDMOD1	External DMA Mode Register 1
0xFFFF1410	FFTHRP	FIFO Threshold for Pixel FIFO
0xFFFF1414	Reserved	Reserved
0xFFFF1418	Reserved	Reserved
0xFFFF141C	FFTHRC	FIFO Threshold for CODE FIFO
0xFFFF1420	FFTHRA	FIFO Threshold for ATTR FIFO
0xFFFF1428 to 0xFFFF14FC	Reserved	Reserved

PLL

The ADV202 uses the PLL_HI and PLL_LO direct registers to configure the PLL. Any time the PLL_LO register is modified, the host must wait at least 20 μs before reading or writing to any other register. If this delay is not implemented, erratic behavior could result.

The PLL can be programmed to have any possible final multiplier value as long as

- JCLK > 50 MHz and < 150 MHz (144-lead version).
- JCLK > 50 MHz and < 135 MHz (144-lead version).
- JCLK > 50 MHz and < 115 MHz (121-lead version).
- HCLK < 108 MHz (144-lead, 150 MHz version).
- HCLK < 100 MHz (144-lead, 135 MHz version).
- HCLK < 81 MHz (121-lead version).
- JCLK ≥ 2 × VCLK for single-component input.
- JCLK ≥ 2 × VCLK for YCrCb [4:2:2] input.
- In JDATA mode (JDATA), JCLK must be 4 × MCLK or higher.
- For de-interlaced modes, JCLK must be ≥ 4 × MCLK.

- The maximum burst frequency for external DMA modes is ≤0.36 JCLK.
- For MCLK frequencies greater than 50 MHz, the input clock divider must be enabled, that is, IPD set to 1.
- IPD cannot be enabled for MCLK frequencies below 20 MHz.

To achieve the lowest power consumption, an MCLK frequency of 27 MHz is recommended for a standard definition CCIR656 input. The PLL circuit is recommended to have a multiplier of 3. This sets JCLK and HCLK to 81 MHz.

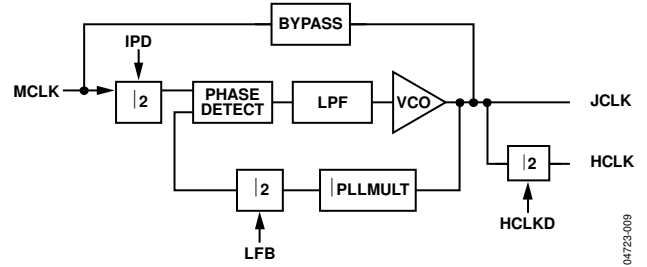

Figure 23. PLL Architecture and Control Functions

Table 21. Recommended PLL Register Settings

IPD	LFB	PLLMULT	HCLKD	HCLK	JCLK
0	0	N	0	N × MCLK	N × MCLK
0	0	N	1	N × MCLK/2	N × MCLK
0	1	N	0	2 × N × MCLK	2 × N × MCLK
0	1	N	1	N × MCLK	2 × N × MCLK
1	0	N	0	N × MCLK/2	N × MCLK/2
1	0	N	1	N × MCLK/4	N × MCLK/2
1	1	N	0	N × MCLK	N × MCLK
1	1	N	1	N × MCLK/2	N × MCLK

Table 22. Recommended Values for PLL_HI and PLL_LO Registers

Video Standard	CLKIN Frequency on MCLK	PLL_HI	PLL_LO
SMPTE125M or ITU-R.BT656 (NTSC or PAL)	27 MHz	0x0008	0x0004
SMPTE293M (525p)	27 MHz	0x0008	0x0004
ITU-R.BT1358 (625p)	27 MHz	0x0008	0x0004
SMPTE274M (1080i)	74.25 MHz	0x0008	0x0084

HARDWARE BOOT

The boot mode can be configured via hardware using the CFG pins or via software (see the *ADV202 User's Guide*). The first boot mode after power-up is set by the CFG pins. Only Boot Mode 2, Boot Mode 4, and Boot Mode 6, described in Table 23, are available via hardware.

Table 23. Hardware Boot Modes

Boot Mode	Settings	Description
Hardware Boot Mode 2	CFG[1] tied high, CFG[2] tied low	No-Boot Host Mode. ADV202 does not boot, but all internal registers and memory are accessible through normal host I/O operations. For details, see the <i>ADV202 User's Guide</i> and the <i>Getting Started with the ADV202</i> application note.
Hardware Boot Mode 4	CFG[1] tied low, CFG[2] tied high	SoC Boot Mode.
Hardware Boot Mode 6	CFG[1] and CFG[2] tied high	Reserved.

VIDEO INPUT FORMATS

The ADV202 supports a wide variety of formats for uncompressed video and still image data. The actual interface and bus modes selected for transferring uncompressed data dictates the allowed size of the input data and the number of samples transferred with each access.

The host interface can support 8-, 10-, 12-, 14-, and 16-bit data formats. The video interface can support video data or still image data input/output. Supported formats are 8-, 10-, 12-, or 16-bit

single component or YCbCr 4:2:2 formats. See the [ADV202 User's Guide](#) for details. All formats can support less precision than provided by specifying the actual data width/precision in the PMODE register.

The maximum allowable data input rate is limited by using irreversible or reversible compression modes and the data width (or precision) of the input samples. Use Table 24 and Table 25 to determine the maximum data input rate.

Table 24. Maximum Pixel Data Input Rates

Interface	Compression Mode	Input Format	Input Rate Limit Active Resolution (MSPS) ¹	Approx Min Output Rate, Compressed Data ² (Mbps)	Approx Max Output Rate, Compressed Data ³ (Mbps)
144-LEAD PACKAGE					
HDATA	Irreversible	8-bit data	45 [40]	130	200
	Irreversible	10-bit data	45 [40]	130	200
	Irreversible	12-bit data	45 [40]	130	200
	Irreversible	16-bit data	45 [40]	130	200
	Reversible	8-bit data	40 [36]	130	200
	Reversible	10-bit data	32 [28]	130	200
	Reversible	12-bit data	27 [24]	130	200
	Reversible	14-bit data	23 [20]	130	200
VDATA	Irreversible	8-bit data	65 [55]	130	200
	Irreversible	10-bit data	65 [55]	130	200
	Irreversible	12-bit data	65 [55]	130	200
	Reversible	8-bit data	40 [34]	130	200
	Reversible	10-bit data	32 [28]	130	200
	Reversible	12-bit data	27 [23]	130	200
121-LEAD PACKAGE					
HDATA	Irreversible	8-bit data	34	98	150
	Irreversible	10-bit data	34	98	150
	Irreversible	12-bit data	34	98	150
	Irreversible	16-bit data	34	98	150
	Reversible	8-bit data	30	98	150
	Reversible	10-bit data	24	98	150
	Reversible	12-bit data	20	98	150
	Reversible	14-bit data	17	98	150
VDATA	Irreversible	8-bit data	48	98	150
	Irreversible	10-bit data	48	98	150
	Irreversible	12-bit data	48	98	150
	Reversible	8-bit data	30	98	150
	Reversible	10-bit data	24	98	150
	Reversible	12-bit data	20	98	150

¹ Input rate limits for HDATA can be less for certain applications depending on input picture size and content, host interface settings, and DMA transfer settings. Values in brackets refer to the 135 MHz speed grade version of the ADV202.

² Minimum guaranteed sustained output rate or minimum sustainable compression rate (input rate/minimum peak output rate).

³ Maximum peak output rate, or output rate above this value is not possible.

Table 25. Maximum Supported Tile Width for Data Input on HDATA and VDATA Buses

Compression Mode	Input Format	Tile/Precinct Maximum Width
9/7i	Single-component	2048
9/7i	Two-component	1024 each
9/7i	Three-component	1024 (Y)
5/3i	Single-component	4096
5/3i	Two-component	2048 (each)
5/3i	Three-component	2048 (Y)
5/3r	Single-component	4096
5/3r	Two-component	2048
5/3r	Three-component	1024

APPLICATIONS

This section describes typical video applications for the ADV202 JPEG2000 video processor.

ENCODE—MULTICHIP MODE

Due to the data input rate limitation (see Table 24), an 1080i application requires at least two ADV202s to encode or decode full-resolution 1080i video. In encode mode, the ADV202 accepts Y and CbCr data on separate buses. The input data must be in EAV/SAV format. An encode example is shown in Figure 24.

In decode mode, a master/slave configuration (as shown in Figure 25) or a slave/slave configuration can be used to synchronize the outputs of the two ADV202s. See AN-796 [ADV202 Multichip Application](#) application note for details on how to configure the ADV202s in a multichip application.

Applications that have two separate VDATA outputs sent to an FPGA or buffer before they are sent to an encoder do not require synchronization at the ADV202 outputs

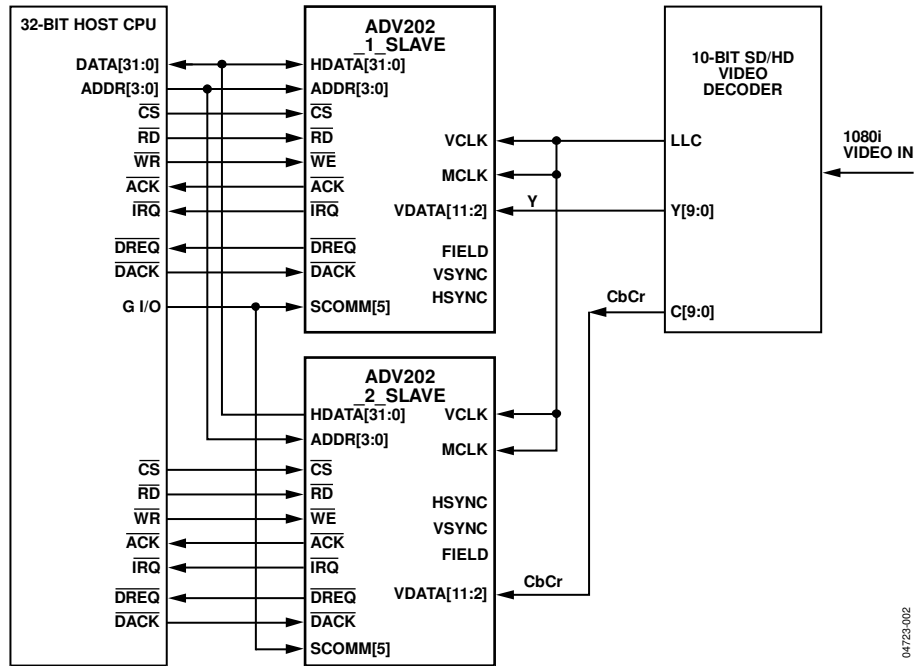

Figure 24. Encode—Multichip Application

04723-002

DECODE—MULTICHIP MASTER/SLAVE

In a master/slave configuration, it is expected that the master HVF outputs are connected to the slave HVF inputs and that each SCOMM[5] pin is connected to the same GPIO on the host.

In a slave/slave configuration, the common HVF for both ADV202s is generated by an external house sync, and each SCOMM[5] is connected to the same GPIO output on the host. SWIRQ1, Software Interrupt 1 in the EIRQIE register, must be unmasked on both devices to enable multichip mode.

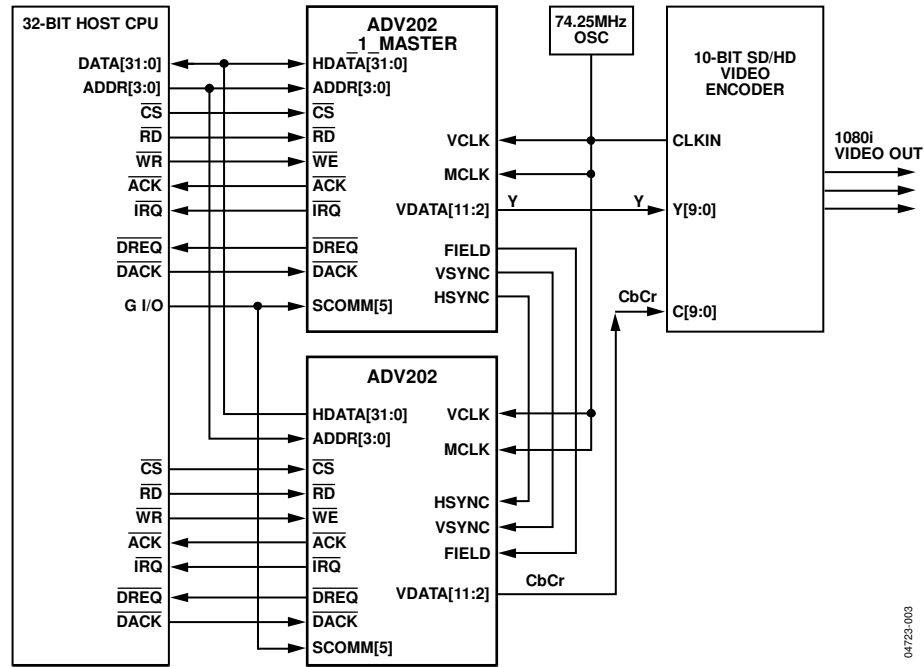

Figure 25. Decode—Multichip Master/Slave Application

DIGITAL STILL CAMERA/CAMCORDER

Figure 26 is a typical configuration for a digital camera or camcorder.

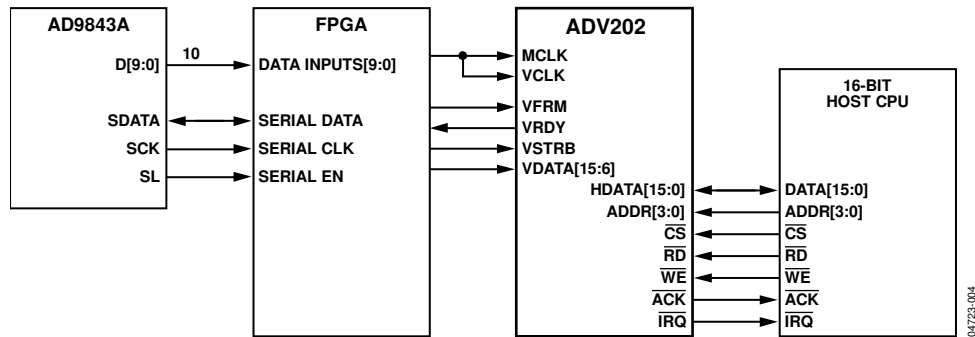

Figure 26. Digital Still Camera/Camcorder Encode Application for 10-Bit Pixel Data Using Raw Pixel Mode

ENCODE/DECODE SDTV VIDEO APPLICATION

Figure 27 shows two ADV202 chips using 10-bit CCIR656 in normal host mode.

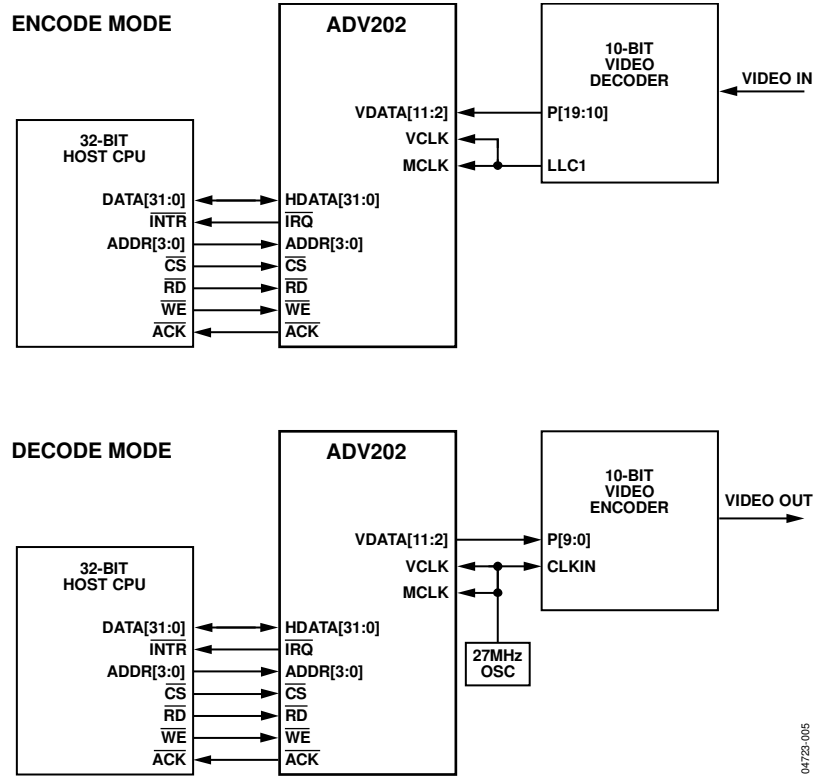

Figure 27. Encode/Decode—SDTV Video Application

04725-005

ASIC APPLICATION (32-BIT HOST/32-BIT ASIC)

Figure 28 shows two ADV202 chips using 10-bit CCIR656 in normal host mode.

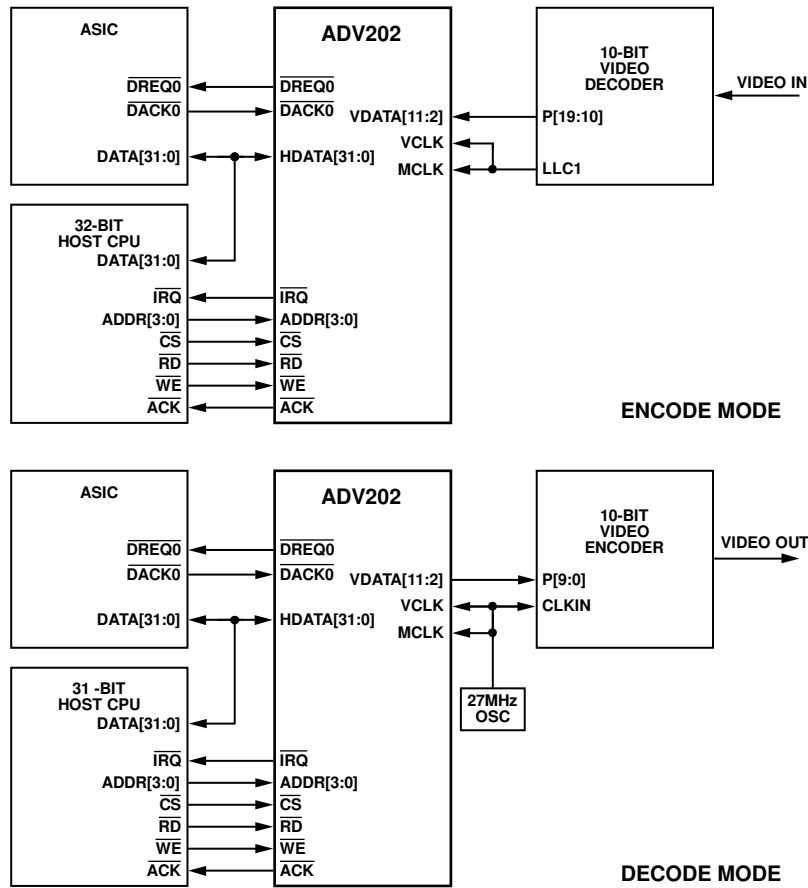

Figure 28. Encode/Decode ASIC Application

04723-006

HIPI (HOST INTERFACE—PIXEL INTERFACE)

Figure 29 is a typical configuration using HIPI mode.

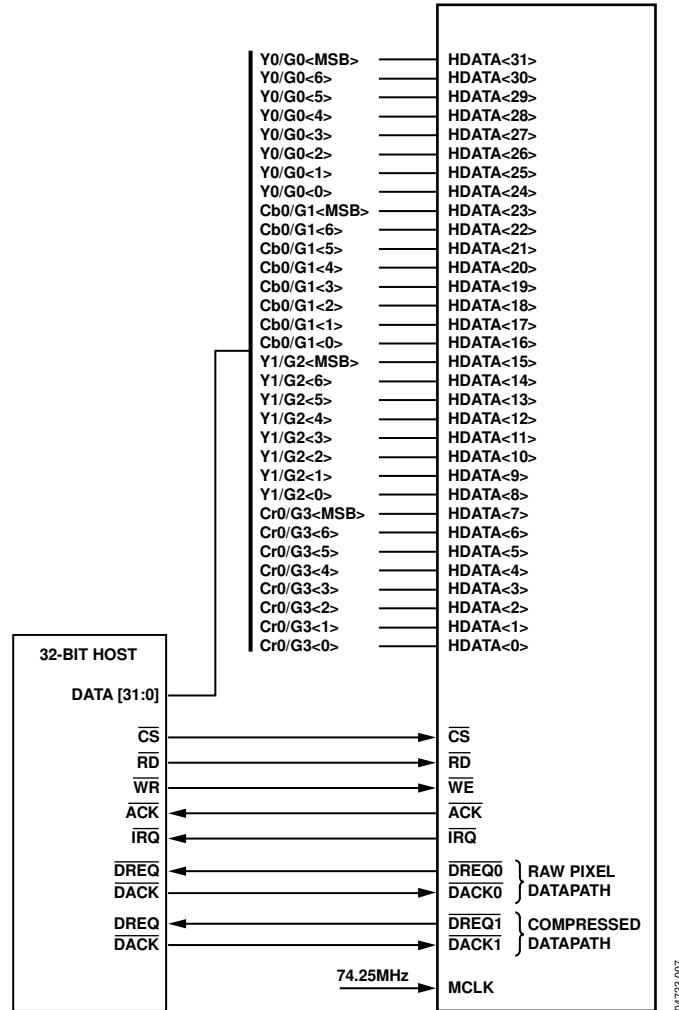

Figure 29. Host Interface—Pixel Interface Mode

JDATA INTERFACE

Figure 30 shows a typical configuration using JDATA with a dedicated JDATA output, 16-bit host, and 10-bit CCIR656.

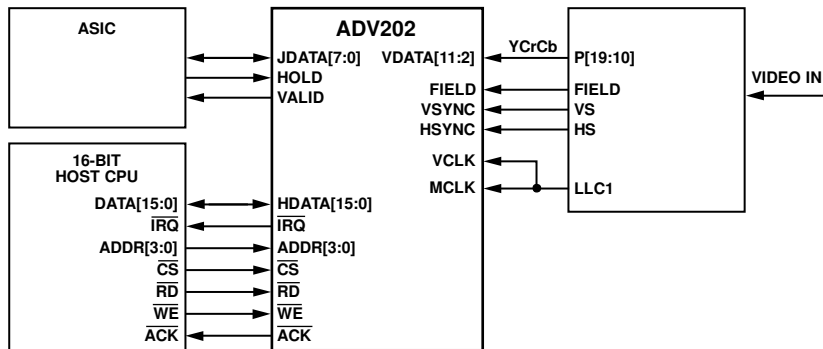
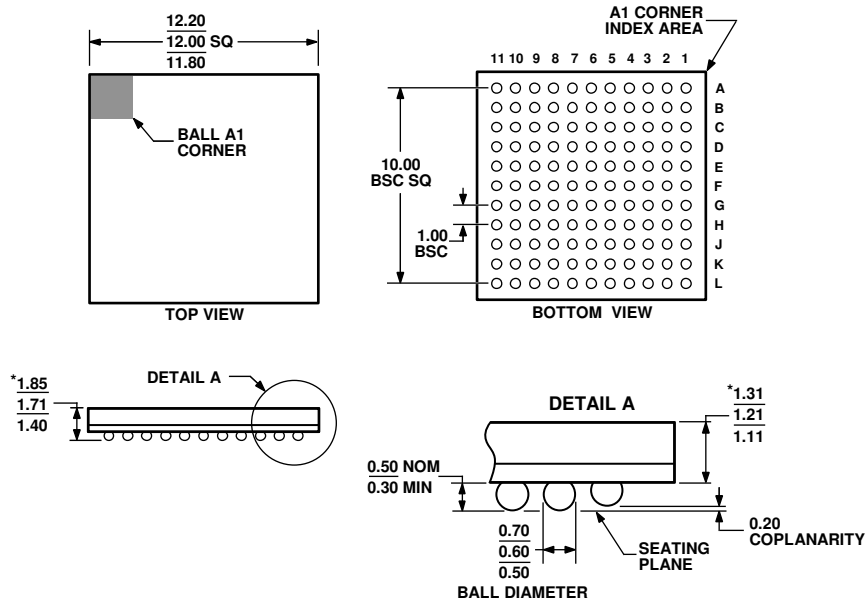

Figure 30. JDATA Application

OUTLINE DIMENSIONS



*COMPLIANT WITH JEDEC STANDARDS MO-192-ABD-1 WITH EXCEPTION TO PACKAGE HEIGHT AND THICKNESS.

Figure 31. 121-Lead Chip Scale Package Ball Grid Array [CSP_BGA] (BC-121-1)

Dimensions shown in millimeters

082406-A

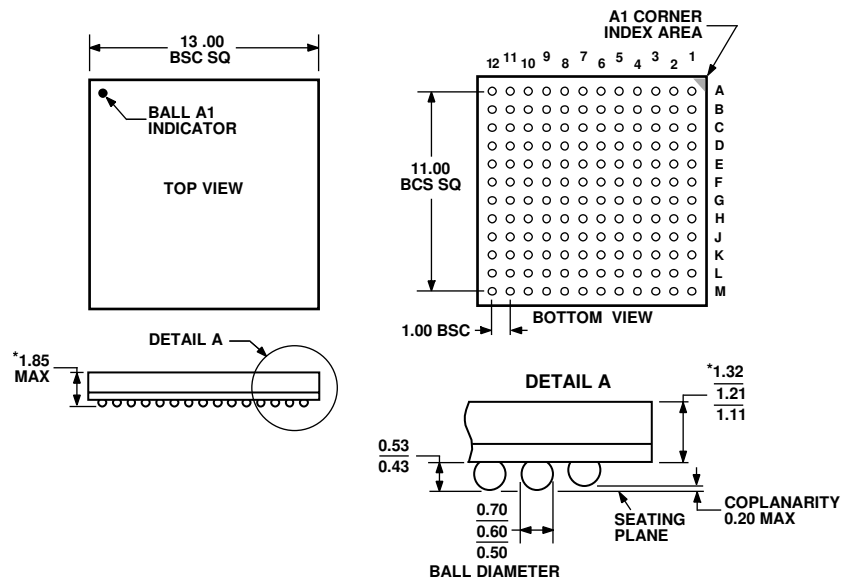

*COMPLIANT WITH JEDEC STANDARDS MO-192-AAD-1 WITH EXCEPTION TO PACKAGE HEIGHT AND THICKNESS.

Figure 32. 144-Lead Chip Scale Package Ball Grid Array [CSP_BGA] (BC-144-3)

Dimensions shown in millimeters

021506-A

ORDERING GUIDE

Model ¹	Temperature Range	Speed Grade	Operating Voltage	Package Description	Package Option
ADV202BBCZ-115	−40°C to +85°C	115 MHz	1.5 V Internal, 2.5 V or 3.3 V I/O	121-Lead CSP_BGA	BC-121-1
ADV202BBCZRL-115	−40°C to +85°C	115 MHz	1.5 V Internal, 2.5 V or 3.3 V I/O	121-Lead CSP_BGA	BC-121-1
ADV202BBCZ-135	−40°C to +85°C	135 MHz	1.5 V Internal, 2.5 V or 3.3 V I/O	144-Lead CSP_BGA	BC-144-3
ADV202BBCZ-150	−40°C to +85°C	150 MHz	1.5 V Internal, 2.5 V or 3.3 V I/O	144-Lead CSP_BGA	BC-144-3
ADV202BBCZRL-150	−40°C to +85°C	150 MHz	1.5 V Internal, 2.5 V or 3.3 V I/O	144-Lead CSP_BGA	BC-144-3

¹ Z = RoHS Compliant Part.