

1A Battery Gas Gauge with Internal Sense Resistor and Temperature/Voltage Measurement

FEATURES

- Indicates Accumulated Battery Charge and Discharge
- SMBus/I²C Interface
- Integrated 50mΩ High Side Sense Resistor
- ±1A Sense Current Range
- High Accuracy Analog Integration
- ADC Measures Battery Voltage and Temperature
- Integrated Temperature Sensor
- 1% Voltage and Charge Accuracy
- Configurable Alert Output/Charge Complete Input
- 2.7V to 5.5V Operating Range
- Quiescent Current Less than 100μA
- Small 6-Pin 2mm × 3mm DFN package

APPLICATIONS

- Low Power Handheld Products
- Cellular Phones
- MP3 Players
- Cameras
- GPS

DESCRIPTION

The LTC[®]2942-1 measures battery charge state, battery voltage and chip temperature in handheld PC and portable product applications. Its operating range is perfectly suited for single cell Li-Ion batteries. A precision coulomb counter integrates current through an internal sense resistor between the battery's positive terminal and the load or charger. Battery voltage and on-chip temperature are measured with an internal 14-bit No Latency $\Delta\Sigma$ [™] ADC. The three measured quantities (charge, voltage and temperature) are stored in internal registers accessible via the onboard SMBus/I²C interface.

The LTC2942-1 features programmable high and low thresholds for all three measured quantities. If a programmed threshold is exceeded, the device communicates an alert using either the SMBus alert protocol or by setting a flag in the internal status register.

LT, LTC, LTM, Linear Technology and the Linear logo are registered trademarks and No Latency $\Delta\Sigma$, ThinSOT and Bat-Track are trademarks of Linear Technology Corporation. All other trademarks are the property of their respective owners.

TYPICAL APPLICATION

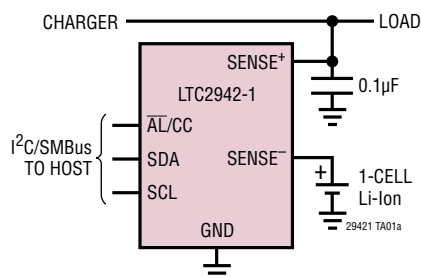

Total Charge Error vs Sense Current

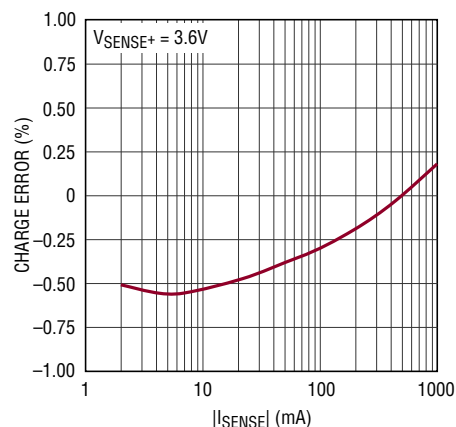

29421 TA01b

LTC2942-1

ABSOLUTE MAXIMUM RATINGS

(Notes 1, 2)

Supply Voltage (SENSE ⁺)	-0.3V to 6V
SCL, SDA, $\overline{\text{AL/CC}}$	-0.3V to 6V
Sense Current (into SENSE ⁻)	±2A
Operating Ambient Temperature Range	
LTC2942-1C	0°C to 70°C
LTC2942-1I	-40°C to 85°C
Storage Temperature Range	-65°C to 150°C

PIN CONFIGURATION

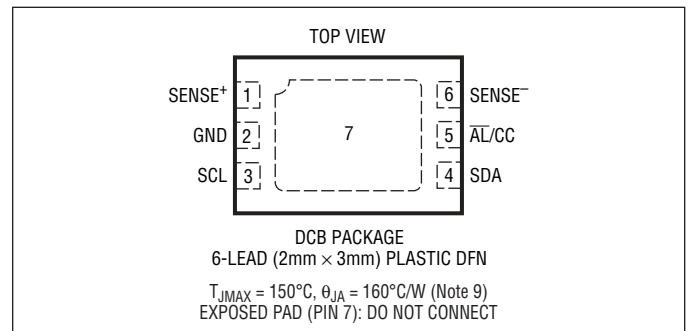

ORDER INFORMATION

Lead Free Finish

TAPE AND REEL (MINI)	TAPE AND REEL	PART MARKING*	PACKAGE DESCRIPTION	TEMPERATURE RANGE
LTC2942CDCB-1#TRMPBF	LTC2942CDCB-1#TRPBF	LDYR	6-Lead (2mm × 3mm) Plastic DFN	0°C to 70°C
LTC2942IDCB-1#TRMPBF	LTC2942IDCB-1#TRPBF	LDYR	6-Lead (2mm × 3mm) Plastic DFN	-40°C to 85°C

TRM = 500 pieces. *Temperature grades are identified by a label on the shipping container.

Consult LTC Marketing for parts specified with wider operating temperature ranges.

Consult LTC Marketing for information on lead based finish parts.

For more information on lead free part marking, go to: <http://www.linear.com/leadfree/>

For more information on tape and reel specifications, go to: <http://www.linear.com/tapeandreel/>

ELECTRICAL CHARACTERISTICS

The ● denotes the specifications which apply over the full operating temperature range, otherwise specifications are at T_A = 25°C. (Note 2)

SYMBOL	PARAMETER	CONDITIONS	MIN	TYP	MAX	UNITS	
Power Requirements							
V _{SENSE+}	Supply Voltage		2.7		5.5	V	
I _{SUPPLY}	Supply Current (Note 3)	Battery Gas Gauge On, ADC Sleep		70	100	μA	
		Battery Gas Gauge On, ADC Converting Voltage	●		300	400	μA
		Battery Gas Gauge On, ADC Converting Temperature	●		350	450	μA
		Shutdown	●			2.5	μA
		Shutdown, V _{SENSE+} ≤ 4.2V				1	μA
V _{UVLO}	Undervoltage Lockout Threshold	V _{SENSE+} Falling	●	2.5	2.6	2.7	V
Coulomb Counter							
I _{SENSE-}	Sense Current				±1	A	
R _{SENSE}	Internal Sense Resistance			50		mΩ	
R _{PP}	Pin-to-Pin Resistance from SENSE ⁺ to SENSE ⁻	(Note 8)	50	74	100	mΩ	
q _{LSB}	Charge LSB (Note 4)	Prescaler M = 128 (Default)		0.085		mAh	
TCE	Total Charge Error (Note 5)	0.2A ≤ I _{SENSE-} ≤ 1A DC			±1	%	
		0.2A ≤ I _{SENSE-} ≤ 1A DC, 0°C to 70°C			±1.8	%	
		0.02A ≤ I _{SENSE-} ≤ 1A DC (Note 8)	●			±2.8	%

29421f

ELECTRICAL CHARACTERISTICS

The ● denotes the specifications which apply over the full operating temperature range, otherwise specifications are at $T_A = 25^\circ\text{C}$. (Note 2)

SYMBOL	PARAMETER	CONDITIONS	MIN	TYP	MAX	UNITS
Voltage Measurement ADC						
	Resolution (No Missing Codes)	(Note 8)	●	14		Bits
V_{FS}	Full-Scale Voltage		●	6		V
ΔV_{LSB}	Quantization Step of 14-Bit Voltage ADC	(Note 6)		366.2		μV
TUE_V	Voltage Total Unadjusted Error		●		1 1.3	% %
Gain	Gain Accuracy		●		1.3	%
V_{OS}	Offset	Extrapolated from Measurements at 5.5V and 2.7V		± 1	± 10	LSB
INL	Integral Nonlinearity		●	± 1	± 4	LSB
t_{CONV}	Conversion Time		●		15	ms
Temperature Measurement ADC						
	Resolution (No Missing Code)	(Note 8)		10		Bits
T_{FS}	Full-Scale Temperature	(Note 10)	●	600		K
ΔT_{LSB}	Quantization Step of 10-Bit Temperature ADC	(Note 6)		0.586		K
TUE_T	Temperature Total Unadjusted Error	$V_{SENSE+} \geq 2.8\text{V}$ (Note 8)	●		± 5 ± 3	K K
t_{CONV}	Conversion Time		●		15	ms
Digital Inputs and Digital Outputs						
V_{ITH}	Logic Input Threshold, $\overline{A}/\overline{CC}$, SCL, SDA		●	$0.3 \cdot V_{SENSE+}$	$0.7 \cdot V_{SENSE+}$	V
V_{OL}	Low Level Output Voltage, $\overline{A}/\overline{CC}$, SDA	$I = 3\text{mA}$	●		0.4	V
I_{IN}	Input Leakage, $\overline{A}/\overline{CC}$, SCL, SDA	$V_{IN} = V_{SENSE+}/2$	●		1	μA
C_{IN}	Input Capacitance, $\overline{A}/\overline{CC}$, SCL, SDA	(Note 8)	●		10	pF
t_{PCC}	Minimum Charge Complete (CC) Pulse Width				1	μs
I²C Timing Characteristics						
$f_{SCL(MAX)}$	Maximum SCL Clock Frequency		●	400	900	kHz
$t_{BUF(MIN)}$	Bus Free Time Between Stop/Start		●		1.3	μs
$t_{SU,STA(MIN)}$	Minimum Repeated Start Set-Up Time		●		600	ns
$t_{HD,STA(MIN)}$	Minimum Hold Time (Repeated) Start Condition		●		600	ns
$t_{SU,STO(MIN)}$	Minimum Set-Up Time for Stop Condition		●		600	ns
$t_{SU,DAT(MIN)}$	Minimum Data Setup Time Input		●		100	ns

ELECTRICAL CHARACTERISTICS

The ● denotes the specifications which apply over the full operating temperature range, otherwise specifications are at $T_A = 25^\circ\text{C}$. (Note 2)

SYMBOL	PARAMETER	CONDITIONS	MIN	TYP	MAX	UNITS
$t_{\text{HD, DATI(MIN)}}$	Minimum Data Hold Time Input		●		0	μs
$t_{\text{HD, DATO}}$	Data Hold Time Output		●	0.3	0.9	μs
t_{of}	Data Output Fall Time	(Notes 7, 8)	●	$20 + 0.1 \cdot C_B$	300	ns

Note 1: Stresses beyond those listed under Absolute Maximum Ratings may cause permanent damage to the device. Exposure to any Absolute Maximum Rating condition for extended periods may affect device reliability and lifetime.

Note 2: All currents into pins are positive, all voltages are referenced to GND unless otherwise specified

Note 3: $I_{\text{SUPPLY}} = I_{\text{SENSE}^+} + I_{\text{SENSE}^-}$

Note 4: The equivalent charge of an LSB in the accumulated charge register depends on the setting of the internal prescaling factor M:

$$q_{\text{LSB}} = 0.085\text{mAh} \cdot \frac{M}{128}$$

See Choosing Coulomb Counter Prescaler M section for more information.
 $1\text{mAh} = 3.6\text{C}$ (Coulombs).

Note 5: Deviation of q_{LSB} from its nominal value. Data is for a new device and does not include long-term sense resistor aging. See the Internal Sense Resistor section for more information.

Note 6: The quantization step of the 14-bit ADC in voltage mode and 10-bit ADC in temperature mode is not to be mistaken with the LSB of the combined 16-bit voltage registers (I, J) and 16-bit temperature registers (M, N).

Note 7: C_B = Capacitance of one bus line in pF ($10\text{pF} \leq C_B \leq 400\text{pF}$). See Voltage and Temperature Registers section for more information.

Note 8: Guaranteed by design, not subject to test.

Note 9: Value decreases if exposed pad is soldered to large copper area. See Power Dissipation section for more information.

Note 10: Use for scaling of temperature reading only. Do not use part outside operating temperature range.

TIMING DIAGRAM

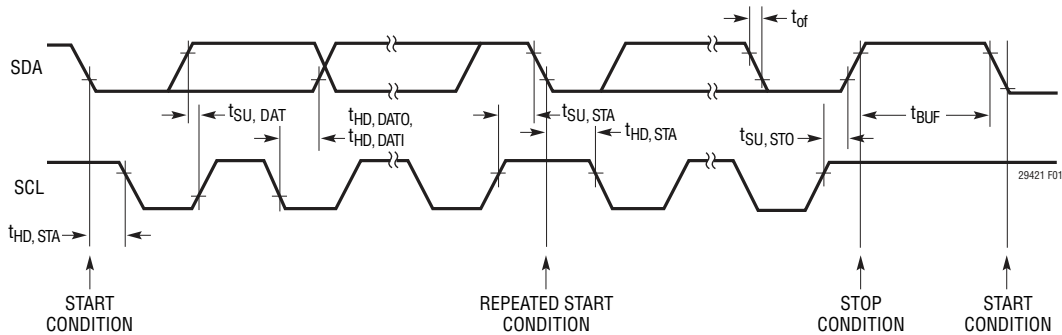
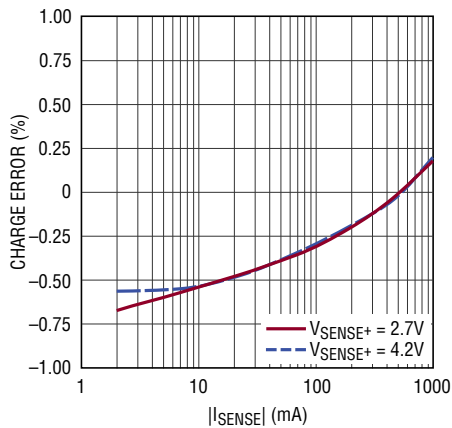

Figure 1. Definition of Timing on I²C Bus

TYPICAL PERFORMANCE CHARACTERISTICS

Total Charge Error vs Sense Current



29421 G01

Total Charge Error vs Supply Voltage

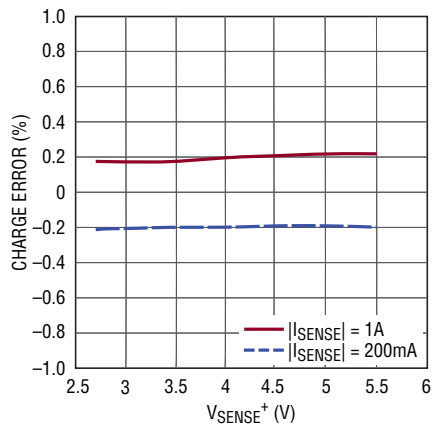

29421 G02

Total Charge Error vs Temperature

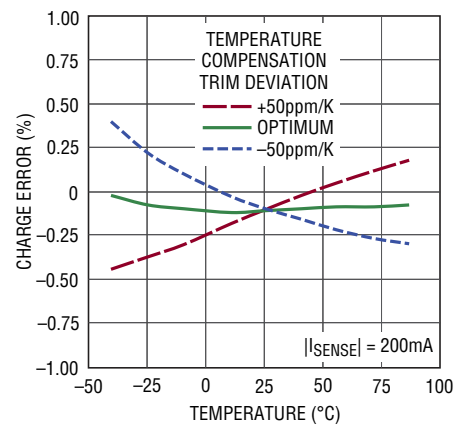

24921 G03

Supply Current vs Supply Voltage

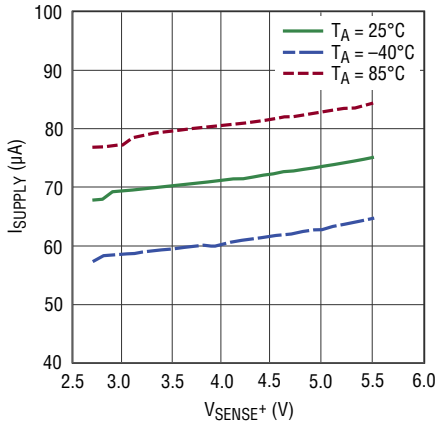

29421 G04

Shutdown Supply Current vs Supply Voltage

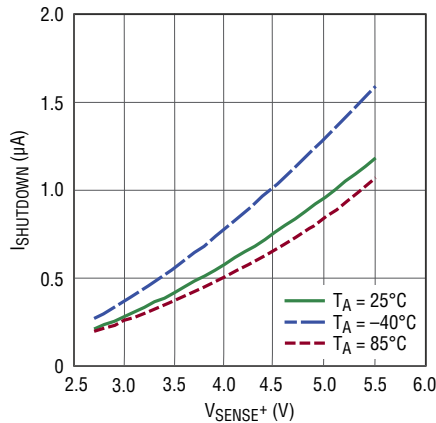

29421 G05

Voltage Measurement ADC Total Unadjusted Error

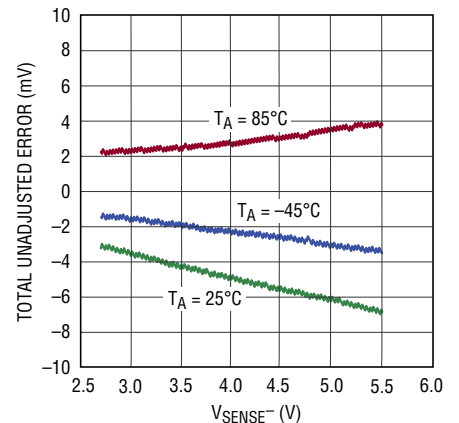

29421 G06

Voltage Measurement ADC Integral Nonlinearity

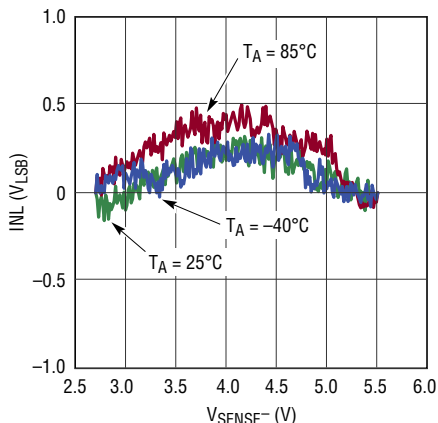

29421 G07

Temperature Error vs Temperature

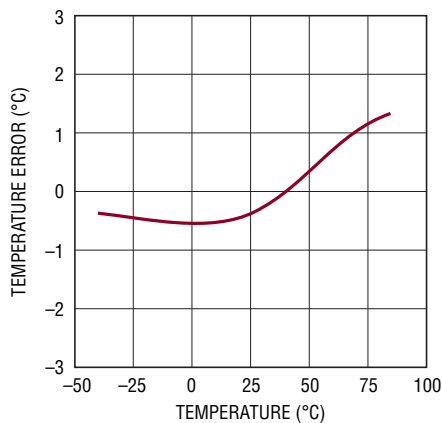

29421 G08

Sense Resistor Stability

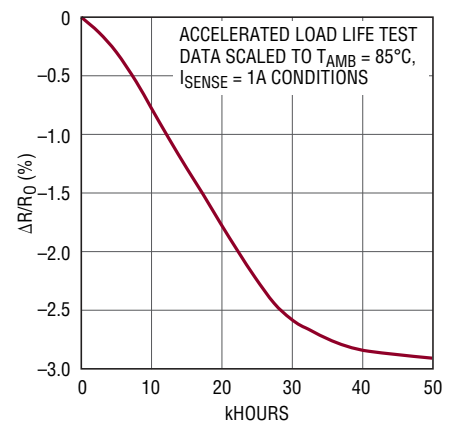

29421 G09

PIN FUNCTIONS

SENSE⁺ (Pin 1): Positive Current Sense Input and Power Supply. Connect to the load and battery charger output. V_{SENSE^+} operating range is 2.7V to 5.5V.

GND (Pin 2): Device Ground. Connect directly to the negative battery terminal.

SCL (Pin 3): Serial Bus Clock Input.

SDA (Pin 4): Serial Bus Data Input and Output.

$\overline{\text{AL}}/\text{CC}$ (Pin 5): Alert Output or Charge Complete Input. Configured either as an SMBus alert output or charge complete input by control register bits B[2:1]. At power-up, the pin defaults to alert mode conforming to the SMBus alert response protocol. It behaves as an open-drain logic

output that pulls to GND when any threshold register value is exceeded. When configured as a charge complete input, a high level at CC sets the value of the accumulated charge (registers C, D) to FFFFh. Columb counting starts when the input returns to low level.

SENSE⁻ (Pin 6): Negative Current Sense Input. Connect SENSE⁻ to the positive battery terminal. Current from/into this pin must not exceed 1A in normal operation.

Exposed Pad (Pin 7): Do Not Connect. Soldering the exposed pad to adequate electrically isolated copper area is recommended for best thermal performance, and best accuracy of the integrated temperature sensor.

BLOCK DIAGRAM

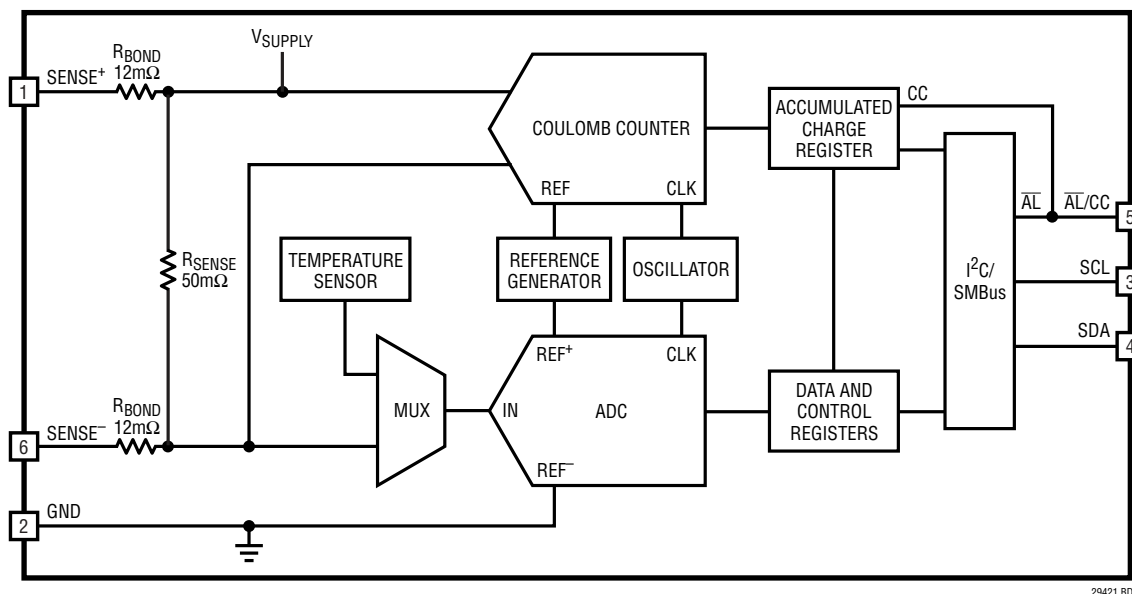

OPERATION

Overview

The LTC2942-1 is a battery gas gauge device designed for use with single Li-Ion cells and other battery types with terminal voltages from 2.7V to 5.5V. It measures battery charge and discharge, battery voltage and chip temperature. A precision coulomb counter integrates current through an internal sense resistor between the

battery's positive terminal and the load or charger. Battery voltage and on-chip temperature are measured with an internal 14-bit/10-bit ADC. The integrated, temperature-compensated sense resistor offers board space savings and superior charge measurement accuracy in applications with currents up to 1A.

OPERATION

Coulomb Counter

Charge is the time integral of current. The LTC2942-1 measures battery current by monitoring the voltage developed across its internal sense resistor and then integrates this information to infer charge. The internal sense resistor is tied between the SENSE⁺ and SENSE⁻ pins and is connected to an auto-zeroed differential analog integrator which converts the measured current to charge.

When the integrator output reaches the REFHI or REFLO thresholds, switches S1, S2, S3 and S4 toggle to reverse the ramp direction. By observing the condition of the switches and the ramp direction, polarity is determined. A programmable prescaler effectively increases integration time by a factor M programmable from 1 to 128. At each underflow or overflow of the prescaler, the accumulated charge register (ACR) value is incremented or decremented one count. The value of accumulated charge is read via the I²C interface.

Voltage and Temperature ADC

The LTC2942-1 includes a 14-bit No Latency $\Delta\Sigma$ analog-to-digital converter, with internal clock and voltage reference circuits.

The ADC can either be used to monitor the battery voltage at SENSE⁻ or to convert the output of the on-chip temperature sensor. The sensor generates a voltage proportional to temperature with a slope of 2.5mV/K resulting in a voltage of 750mV at 27°C.

Conversion of either temperature or voltage is triggered by setting the control register via the I²C interface. The LTC2942-1 features an automatic mode where a voltage and a temperature conversion are executed every two seconds. At the end of each conversion the corresponding registers are updated and the converter goes to sleep to minimize quiescent current.

Power-Up Sequence

When V_{SENSE+} rises above a threshold of approximately 2.5V, the LTC2942-1 generates an internal power-on reset (POR) signal and sets all registers to their default state. In the default state, the coulomb counter is active while the voltage and temperature ADC is switched off. The accumulated charge register is set to mid-scale (7FFFh), all low threshold registers are set to 0000h and all high threshold registers are set to FFFFh. The alert mode is enabled and the coulomb counter pre-scaling factor M is set to 128.

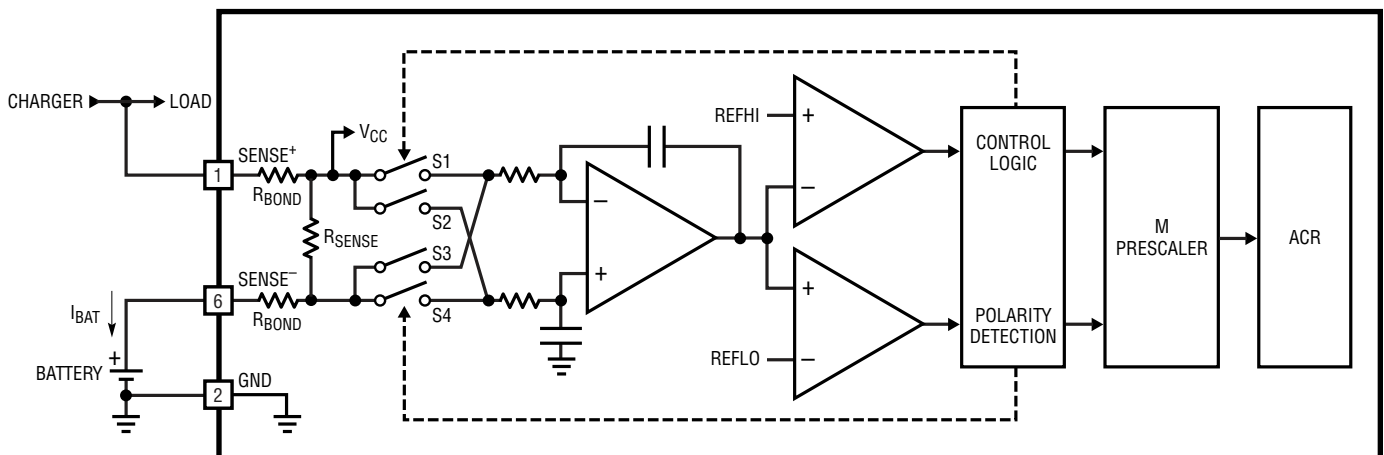

Figure 2. Coulomb Counter Section of the LTC2942-1

APPLICATIONS INFORMATION

I²C/SMBus Interface

The LTC2942-1 communicates with a bus master using a 2-wire interface compatible with I²C and SMBus. The 7-bit hard-coded **I²C address of the LTC2942-1 is 1100100**.

The LTC2942-1 is a slave-only device. Therefore the serial clock line (SCL) is an input only while the serial data line (SDA) is bidirectional. The device supports I²C standard and fast mode. For more details refer to the I²C Protocol section.

Internal Registers

The LTC2942-1 integrates current through a sense resistor, measures battery voltage and temperature and stores the results in internal 16-bit registers accessible via I²C. High and low limits can be programmed for each measurement quantity. The LTC2942-1 continuously monitors these limits and sets a corresponding flag in its status register when a limit is exceeded. If the alert mode is enabled, the $\overline{\text{AL/CC}}$ pin pulls low.

The sixteen internal registers are organized as shown in Table 1.

Table 1. Register Map

ADDRESS	NAME	REGISTER DESCRIPTION	R/W	DEFAULT
00h	A	Status	R	See Below
01h	B	Control	R/W	3Ch
02h	C	Accumulated Charge MSB	R/W	7Fh
03h	D	Accumulated Charge LSB	R/W	FFh
04h	E	Charge Threshold High MSB	R/W	FFh
05h	F	Charge Threshold High LSB	R/W	FFh
06h	G	Charge Threshold Low MSB	R/W	00h
07h	H	Charge Threshold Low LSB	R/W	00h
08h	I	Voltage MSB	R	XXh
09h	J	Voltage LSB	R	XXh
0Ah	K	Voltage Threshold High	R/W	FFh
0Bh	L	Voltage Threshold Low	R/W	00h
0Ch	M	Temperature MSB	R	XXh
0Dh	N	Temperature LSB	R	XXh
0Eh	O	Temperature Threshold High	R/W	FFh
0Fh	P	Temperature Threshold Low	R/W	00h

R = Read, W = Write, XX = unknown

Status Register (A)

The status of the charge, voltage and temperature alerts is reported in the status register shown in Table 2.

Table 2. Status Register A (Read only)

BIT	NAME	OPERATION	DEFAULT
A[7]	Chip Identification	0: LTC2942-1 1: LTC2941-1	0
A[6]	Reserved	Not Used.	0
A[5]	Accumulated Charge Overflow/Underflow	Indicates that the value of the accumulated charge hit either top or bottom.	0
A[4]	Temperature Alert	Indicates one of the temperature limits was exceeded.	0
A[3]	Charge Alert High	Indicates that the accumulated charge value exceeded the charge threshold high limit.	0
A[2]	Charge Alert Low	Indicates that the accumulated charge value dropped below the charge threshold low limit.	0
A[1]	Voltage Alert	Indicates one of the battery voltage limits was exceeded.	0
A[0]	Undervoltage Lockout Alert	Indicates recovery from undervoltage. If set to 1, a UVLO has occurred and the content of the registers is uncertain.	X

All status register bits except A[7] are cleared after being read by the host, if the conditions which set these bits have been removed.

As soon as one of the three measured quantities exceeds the programmed limits, the corresponding bit A[4], A[3], A[2] or A[1] in the status register is set.

Bit A[5] is set if the LTC2942-1's accumulated charge registers (ACR) overflows or underflows. In these cases, the ACR stays at FFFFh or 0000h and does not roll over.

The undervoltage lockout (UVLO) bit of the status register A[0] is set if, during operation, the voltage on SENSE⁺ pin drops below 2.7V without reaching the POR level. The analog parts of the coulomb counter are switched off while the digital register values are retained. After recovery of the supply voltage the coulomb counter resumes integrating with the stored value in the accumulated charge registers but it has missed any charge flowing while SENSE⁺ < 2.7V.

APPLICATIONS INFORMATION

The hard-coded bit A[7] of the status register enables the host to distinguish the LTC2942-1 from the pin compatible LTC2941, allowing the same software to be used with both devices.

Control Register (B)

The operation of the LTC2942-1 is controlled by programming the control register. Table 3 shows the organization of the 8-bit control register B[7:0].

Table 3. Control Register B

BIT	NAME	OPERATION	Default
B[7:6]	ADC Mode	[11] Automatic Mode. Performs voltage and temperature conversion every second. [10] Manual Voltage Mode. Performs single voltage conversion, then sleeps. [01] Manual Temperature Mode. Performs single temperature conversion, then sleeps. [00] Sleep.	[00]
B[5:3]	Prescaler M	Sets coulomb counter prescaling factor M between 1 and 128. Default is 128. $M = 2^{(4 \cdot B[5] + 2 \cdot B[4] + B[3])}$	[111]
B[2:1]	\overline{AL}/CC Configure	Configures the \overline{AL}/CC pin. [10] Alert Mode. Alert functionality enabled. Pin becomes logic output. [01] Charge Complete Mode. Pin becomes logic input and accepts "charge complete" signal (e.g., from a charger) to set accumulated charge register (C,D) to FFFFh. [00] \overline{AL}/CC pin disabled. [11] Not allowed.	[10]
B[0]	Shutdown	Shut down analog section to reduce I_{SUPPLY} .	[0]

Power Down B[0]

Programming the last bit B[0] of the control register to 1 sets the analog parts of the LTC2942-1 in power down and the current consumption drops typically below 1 μ A. All analog circuits are disabled while the values in the registers are retained. Note that any charge flowing while B[0] is 1 is not measured and the charge information below 1LSB of the accumulated charge register is lost.

Alert/Charge Complete Configuration B[2:1]

The \overline{AL}/CC pin is a dual function pin configured by the control register. By setting bits B[2:1] to [10] (default) the \overline{AL}/CC pin is configured as an alert pin following the SMBus protocol. In this configuration the \overline{AL}/CC pin is a digital output and is pulled low if one of the three measured quantities (charge, voltage, temperature) exceeds its high or low threshold or if the value of the accumulated charge register overflows or underflows. An alert response procedure started by the master resets the alert at the \overline{AL}/CC pin. For further information see the Alert Response Protocol section.

Setting the control bits B[2:1] to [01] configures the \overline{AL}/CC pin as a digital input. In this mode, a high input on the \overline{AL}/CC pin communicates to the LTC2942-1 that the battery is full and the accumulated charge register is set to its maximum value FFFFh. Columb counting starts when the \overline{AL}/CC pin returns to low level.

If neither the alert nor the charge complete functionality is desired, bits B[2:1] should be set to [00]. The \overline{AL}/CC pin is then disabled and should be tied to GND.

Avoid setting B[2:1] to [11] as it enables the alert and the charge complete modes simultaneously.

Choosing Coulomb Counter Prescaler 'M' B[5:3]

To use as much of the range of the accumulated charge register as possible the prescaler factor M is chosen based on battery capacity Q_{BAT} :

$$M \geq 128 \cdot \frac{Q_{BAT}}{2^{16} \cdot 0.085\text{mAh}} = \frac{23}{\text{Ah}} \cdot Q_{BAT}$$

M can be set to 1, 2, 4, 8, ... 128 by programming B[5:3] of the control register as $M = 2^{(4 \cdot B[5] + 2 \cdot B[4] + B[3])}$. The default value after power up is $M = 128 = 2^7$ (B[5:3] = 111). The maximum battery capacity supported within the prescaler range is 5.5Ah with $M = 128$. See the section Extending Coulomb Counter Range if battery capacity is higher.

Depending on the choice of prescaler factor M, the charge LSB of the accumulated charge register becomes:

$$q_{LSB} = 0.085\text{mAh} \cdot \frac{M}{128}$$

APPLICATIONS INFORMATION

Note that the internal digital resolution of the coulomb counter is higher than indicated by qLSB. The internal charge resolution is typically 299 μ As.

ADC Mode B[7:6]

The LTC2942-1 features an ADC which measures either voltage on SENSE⁻ (battery voltage) or temperature via an internal temperature sensor. The reference voltage and clock for the ADC are generated internally.

The ADC has four different modes of operation as shown in Table 3. These modes are controlled by bits B[7:6] of the control register. At power-up, bits B[7:6] are set to [00] and the ADC is in sleep mode.

A single voltage conversion is initiated by setting the bits B[7:6] to [10]. A single temperature conversion is started by setting bits B[7:6] to [01]. After a single voltage or temperature conversion, the ADC resets B[7:6] to [00] and goes to sleep.

The LTC2942-1 also offers an automatic scan mode where the ADC converts voltage, then temperature, then sleeps for approximately two seconds before repeating the voltage and temperature conversions. The LTC2942-1 is set to this automatic mode by setting B[7:6] to [11] and stays in this mode until B[7:6] are reprogrammed by the host.

Programming B[7:6] to [00] puts the ADC to sleep. If control bits B[7:6] change within a conversion, the ADC will complete the current conversion before entering the newly selected mode.

A conversion of either voltage or temperature requires 10ms conversion time (typical). At the end of each conversion, the corresponding registers are updated. If the converted quantity exceeds the values programmed in the threshold registers, a flag is set in the status register and the \overline{AL}/CC pin is pulled low (if alert mode is enabled).

Accumulated Charge Register (C,D)

The coulomb counter of the LTC2942-1 integrates current through its internal sense resistor over time. The result of this charge integration is stored in the 16-bit accumulated charge register (registers C, D). The amount of charge for

a given register contents (C[7:0]D[7:0]) and prescaler setting M can be calculated by:

$$Q = 0.085\text{mAh} \cdot \frac{M}{128} \cdot (C \cdot 256 + D)$$

The ACR should be read in a single I²C Read transaction (see Figure 10). If C and D are read in individual single-byte transactions, each with a STOP condition, the register may change between the first and the second transaction due to coulomb count events, causing erroneous charge readings.

As the LTC2942-1 does not know the actual battery status at power-up, the accumulated charge register (ACR) is set to mid-scale (7FFFh). If the host knows the status of the battery, the accumulated charge (C[7:0]D[7:0]) can be either programmed to the correct value via I²C or it can be set after charging to FFFFh (full) by pulling the \overline{AL}/CC pin high if charge complete mode is enabled via bits B[2:1]. In this case, FFFFh represents a fully charged battery. If the actual battery capacity is smaller, the host can subtract the excess charge whenever doing the charge calculation, and set the low charge threshold (registers G,H) to the value representing an empty battery. This procedure essentially shifts the zero point of the scale upwards. Before writing the accumulated charge registers, the analog section should be shut down by setting B[0] to 1.

Voltage and Temperature Registers (I, J),(M, N)

The result of the 14-bit ADC conversion of the voltage at SENSE⁻ is stored in the voltage registers (I, J), whereas the temperature measurement result is stored in the temperature registers (M, N). The voltage and temperature registers are read only.

As the ADC resolution is 14-bit in voltage mode and 10-bit in temperature mode, the lowest two bits of the combined voltage registers (I, J) and the lowest six bits of the combined temperature registers (M, N) are always zero. From the result of the 16-bit voltage registers I[7:0]J[7:0] the measured voltage can be calculated as:

$$V_{\text{SENSE}^-} = 6V \cdot \frac{\text{RESULT}_h}{\text{FFFF}_h} = 6V \cdot \frac{\text{RESULT}_{\text{DEC}}}{65535}$$

APPLICATIONS INFORMATION

Example: a register value of $I[7:0] = B0_h$ and $J[7:0] = 1C_h$ corresponds to a voltage on $SENSE^-$ of:

$$V_{SENSE^-} = 6V \cdot \frac{B01C_h}{FFFF_h} = 6V \cdot \frac{45084_{DEC}}{65535} \approx 4.1276V$$

Voltage is measured at the internal bond pads connected to $SENSE^-$, hence, the current flowing through the combined pin and bond wire resistance causes the measured voltage to deviate slightly from the actual battery voltage at the $SENSE^-$ package pin. For the full-scale current of $\pm 1A$ at room temperature, this error is typically $\pm 9mV$, which is negligible in most applications. To increase the precision of the voltage measurement, the error can be reduced by differentiating the coulomb counter data, multiplying the resultant current value by $9\ m\Omega$, and adding or subtracting the result from the voltage measurement. Note that the sign of the error changes depending on the direction of the current flow.

The actual temperature can be obtained from the two byte register $C[7:0]D[7:0]$ by:

$$T = 600K \cdot \frac{RESULT_h}{FFFF_h} = 600K \cdot \frac{RESULT_{DEC}}{65535}$$

Example: a register value of $C[7:0] = 80_h$ $D[7:0] = 00_h$ corresponds to $300K$ or $27^\circ C$.

Temperature is measured on the surface of the chip (T_{DIE}), which may be different from ambient temperature T_{AMB} , especially with high sense resistor currents. To minimize errors in the temperature measurement, the DFN package's exposed pad may be thermally coupled to the body whose temperature is to be measured. With the recommended PCB layout (Figure 11), T_{DIE} typically increases over T_{AMB} by $1K$ for $0.25A$, $3K$ for $0.5A$ and $12K$ for $1A$. Different results may be obtained depending on layout, mounting details, and air flow. Software in the host system can reduce this error if the rise over T_{AMB} is known by differentiating the coulomb counter data to obtain current and using this value to correct the temperature reading.

Threshold Registers (E, F, G, H, K, L, O, P)

For each of the measured quantities (battery charge, voltage and temperature) the LTC2942-1 features a high and a

low threshold registers. At power-up, the high thresholds are set to $FFFF_h$ while the low thresholds are set to 0000_h . All thresholds can be programmed to a desired value via I^2C . As soon as a measured quantity exceeds the high threshold or falls below the low threshold, the LTC2942-1 sets the corresponding flag in the status register and pulls the \overline{AL}/CC pin low if alert mode is enabled via bits $B[2:1]$. Note that the voltage and temperature threshold registers are single byte registers and only the 8 MSBs of the corresponding quantity are checked. To set a low level threshold for the battery voltage of $3V$, register L should be programmed to 80_h ; a high temperature limit of $60^\circ C$ is programmed by setting register O to $8E_h$.

I^2C Protocol

The LTC2942-1 uses an I^2C /SMBus compatible 2-wire open-drain interface supporting multiple devices and masters on a single bus. The connected devices can only pull the bus wires low and they never drive the bus high. The bus wires must be externally connected to a positive supply voltage via a current source or pull-up resistor. When the bus is idle, both SDA and SCL are high. Data on the I^2C bus can be transferred at rates of up to $100kbit/s$ in standard mode and up to $400kbit/s$ in fast mode.

Each device on the I^2C /SMBus is recognized by a unique address stored in that device and can operate as either a transmitter or receiver, depending on the function of the device. In addition to transmitters and receivers, devices can also be classified as masters or slaves when performing data transfers. A master is the device which initiates a data transfer on the bus and generates the clock signals to permit that transfer. At the same time any device addressed is considered a slave. The LTC2942-1 always acts as a slave.

Figure 3 shows an overview of the data transmission for fast and standard mode on the I^2C bus.

Start and Stop Conditions

When the bus is idle, both SCL and SDA must be high. A bus master signals the beginning of a transmission with a START condition by transitioning SDA from high to low while SCL is high. When the master has finished communicating with the slave, it issues a STOP condition by

APPLICATIONS INFORMATION

transitioning SDA from low to high while SCL is high. The bus is then free for another transmission. When the bus is in use, it stays busy if a repeated START (Sr) is generated instead of a STOP condition. The repeated START (Sr) conditions are functionally identical to the START (S).

Data Transmission

After a START condition, the I²C bus is considered busy and data transfer begins between a master and a slave. As data is transferred over I²C in groups of nine bits (eight data bits followed by an acknowledge bit), each group takes nine SCL cycles. The transmitter releases the SDA line during the acknowledge clock pulse and the receiver issues an acknowledge (ACK) by pulling SDA low or leaves SDA high to indicate a not acknowledge (NAK) condition. Change of data state can only happen while SCL is low.

Write Protocol

The master begins a write operation with a START condition followed by the seven bit slave **address 1100100** and the R/W bit set to zero, as shown in Figure 4. The LTC2942-1 acknowledges this by pulling SDA low and then the master sends a command byte which indicates which internal register the master is to write. The LTC2942-1 acknowledges and latches the command byte into its internal register address pointer. The master delivers the data byte, the LTC2942-1 acknowledges once more and latches the data into the desired register. The transmission is ended when the master sends a STOP condition. If the master continues by sending a second data byte instead of a stop, the LTC2942-1 acknowledges again, increments its address pointer and latches the second data byte in the following register, as shown in Figure 5.

Read Protocol

The master begins a read operation with a START condition followed by the seven bit slave **address 1100100** and the R/W bit set to zero, as shown in Figure 6. The LTC2942-1 acknowledges and then the master sends a command byte which indicates which internal register the master is to read. The LTC2942-1 acknowledges and then latches the command byte into its internal register address pointer. The master then sends a repeated START condition followed by the same seven bit address with the R/W bit now set

to one. The LTC2942-1 acknowledges and sends the contents of the requested register. The transmission is ended when the master sends a STOP condition. If the master acknowledges the transmitted data byte, the LTC2942-1 increments its address pointer and sends the contents of the following register as depicted in Figure 7.

Alert Response Protocol

In a system where several slaves share a common interrupt line, the master can use the alert response address (ARA) to determine which device initiated the interrupt (Figure 8).

The master initiates the ARA procedure with a START condition and the special **7-bit ARA bus address (0001100)** followed by the read bit (R) = 1. If the LTC2942-1 is asserting the $\overline{\text{AL/CC}}$ pin in alert mode, it acknowledges and responds by sending its **7-bit bus address (1100100)** and a 1. While it is sending its address, it monitors the SDA pin to see if another device is sending an address at the same time using standard I²C bus arbitration. If the LTC2942-1 is sending a 1 and reads a 0 on the SDA pin on the rising edge of SCL, it assumes another device with a lower address is sending and the LTC2942-1 immediately aborts its transfer and waits for the next ARA cycle to try again. If transfer is successfully completed, the LTC2942-1 will stop pulling down the $\overline{\text{AL/CC}}$ pin and will not respond to further ARA requests until a new Alert event occurs.

Internal Sense Resistor

The internal sense resistor uses proprietary* temperature compensation techniques to reduce the effective temperature coefficient to less than ± 50 ppm/K typically. The effective sense resistance as seen by the coulomb counter is factory trimmed to 50m Ω . Both measures, and the lack of thermocouple effects in the sense resistor connections, contribute to the LTC2942-1's superior charge measurement accuracy compared to competing solutions employing a common 1% tolerance, 50ppm/K tempco discrete current sense resistor.

Like all sense resistors, the integrated sense resistor in the LTC2942-1 will exhibit minor long-term resistance shift. The resistance typically drops less than -0.1% per

*Patent pending.

APPLICATIONS INFORMATION

1000h at 1A current and 85°C ambient temperature; this outperforms most types of discrete sense resistors except those of the *very high* and *ultrahigh* stability variety. See the Typical Performance Characteristics for expected resistor drift performance under worst-case conditions. Drift will be much slower at lower temperatures. Contact LTC applications for more information.

For most coulomb counter applications this aging behavior of the integrated sense resistor is insignificant compared to the change of battery capacity due to battery aging. The LTC2942-1 is factory trimmed to optimum accuracy when new; for applications which require the best possible coulomb count accuracy over the full product lifetime, the coulomb counter gain can be adjusted in software. For instance, if the error contribution of sense resistor drift must be limited to ±1%, coulomb counts may be biased high by 1% (use factor 1.01), and maximum operational temperature and current then must be derated such that

sense resistor drift over product lifetime or calibration intervals is less than -2%.

Applications employing the standard external resistor LTC2942 with an external 50mΩ sense resistor may be upgraded to the pin-compatible LTC2942-1 by removing the external sense resistor.

Voltage Drop Between SENSE⁺ and SENSE⁻

The LTC2942-1 is trimmed for an effective internal resistance of 50mΩ, but the total pin-to-pin resistance (R_{PP}), consisting of the sense resistor in series with pin and bond wire resistances, is somewhat higher. Assuming a sense resistor temperature coefficient of about 3900ppm/K, the total resistance between SENSE⁺ and SENSE⁻ at a temperature T is typically:

$$R_{PP}(T) = R_{PP}(T_{NOM}) [1 + 0.0039(T - T_{NOM})]$$

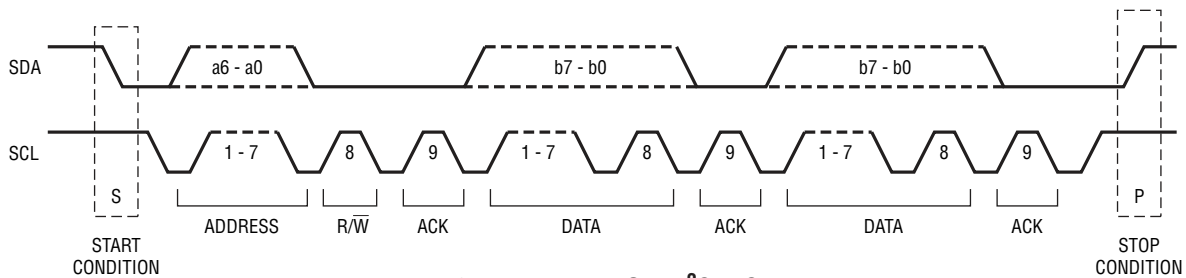

Figure 3. Data Transfer Over I²C or SMBus

S	ADDRESS	W	A	REGISTER	A	DATA	A	P
	1100100	0	0	01h	0	FCh	0	

FROM MASTER TO SLAVE
 FROM SLAVE TO MASTER
 A: ACKNOWLEDGE (LOW)
 \bar{A} : NOT ACKNOWLEDGE (HIGH)
 S: START CONDITION
 P: STOP CONDITION
 R: READ BIT (HIGH)
 W: WRITE BIT (LOW)

Figure 4. Writing FCh to the LTC2942-1 Control Register (B)

S	ADDRESS	W	A	REGISTER	A	DATA	A	DATA	A	P
	1100100	0	0	02h	0	F0h	0	01h	0	

Figure 5. Writing F001h to the LTC2942-1 Accumulated Charge Register (C, D)

S	ADDRESS	W	A	REGISTER	A	S	ADDRESS	R	A	DATA	\bar{A}	P
	1100100	0	0	00h	0		1100100	1	0	01h	1	

Figure 6. Reading the LTC2942-1 Status Register (A)

S	ADDRESS	W	A	REGISTER	A	S	ADDRESS	R	A	DATA	A	DATA	\bar{A}	P
	1100100	0	0	08h	0		1100100	1	0	F1h	0	24h	1	

Figure 7. Reading the LTC2942-1 Voltage Register (I, J)

APPLICATIONS INFORMATION

S	ALERT RESPONSE ADDRESS	R	A	DEVICE ADDRESS	\bar{A}	P
	0001100	1	0	11001001	1	

29421 F08

Figure 8. LTC2942-1 Serial Bus SDA Alert Response Protocol

S	ADDRESS	\bar{W}	A	REGISTER	A	DATA	P	S	ADDRESS	\bar{W}	A	REGISTER	A	S	ADDRESS	R	A	DATA	A	DATA	\bar{A}	P
	1100100	0	0	01h	0	BC			1100100	0	0	08h	0		1100100	1	0	F1h	0	80h	1	

29421 F09

Figure 9. Voltage Conversion Sequence

S	ADDRESS	\bar{W}	A	REGISTER	A	S	ADDRESS	R	A	DATA	A	DATA	\bar{A}	P
	1100100	0	0	02h	0		1100100	1	0	80h	0	01h	1	

29421 F10

Figure 10. Reading the LTC2942-1 Accumulated Charge Registers (C, D)

where $T_{NOM} = 27^{\circ}\text{C}$ (or 300K) and $R_{PP}(T_{NOM})$ is from the Electrical Characteristics table. This means that the resistance between SENSE⁺ and SENSE⁻ may drop by 26% if die temperature changes from 27°C to -40°C or increase by 23% for a 27°C to 85°C die temperature change. Ensure that total voltage drop between SENSE⁺ and SENSE⁻, caused by maximum peak current flowing in/out of SENSE⁻:

$$V_{DROP} = I_{PEAK} \cdot R_{PP}(T_{DIE(MAX)})$$

does not exceed the application's requirements.

Limiting Inrush Current

Inrush currents during events like battery insertion or closure of a mechanical power switch may be substantially higher than peak currents during normal operation. Extremely large inrush currents may require additional circuitry to keep currents through the LTC2942-1 sense resistor below the absolute maximum ratings.

Note that external Schottky clamp diodes between SENSE⁺ and SENSE⁻ can leak significantly, especially at high temperature, which can cause significant coulomb counter errors. Preferred solutions to limit inrush current include active Hot Swap™ current limiting or connector designs that include current limiting resistance and staggered pins to ensure a low impedance connection when the connector is fully mated.

Power Dissipation

Power dissipation in the R_{PP} resistance when operated at high currents can increase the die temperature several degrees over ambient. Soldering the exposed pad of the DFN package to a large copper region on the PCB is recommended for applications operating close to the specified maximum current and ambient temperature. Die temperature at a given I_{SENSE} can be estimated by:

$$T_{DIE} = T_{AMB} + 1.22 \cdot \theta_{JA} \cdot R_{PP(MAX)} \cdot I_{SENSE}^2$$

where the factor 1.22 approximates the effect of sense resistor self-heating, $R_{PP(MAX)}$ is the maximum pad-to-pad resistance at nominal temperature (27°C) and θ_{JA} is the thermal resistance from junction to ambient. The θ_{JA} data given for the DFN package is valid for typical PCB layouts; more precise θ_{JA} data for a particular PCB layout may be obtained by measuring the voltage V_{P-P} between SENSE⁺ and SENSE⁻, the ambient temperature T_{AMB} , and the die temperature T_{DIE} , and calculating:

$$\theta_{JA} = \frac{T_{DIE} - T_{AMB}}{V_{P-P} \cdot I_{SENSE}}$$

Both T_{AMB} and T_{DIE} temperature may be measured using the internal temperature sensor included in the LTC2942-1. I_{SENSE} should be set to zero to measure T_{AMB} , and high enough during T_{DIE} measurement to achieve a significant temperature increase over T_{AMB} .

APPLICATIONS INFORMATION

Measuring Current

In some applications, it may be desirable to measure the current I_{SENSE} flowing through the internal sense resistor. Since charge measured by the coulomb counter is the time integral over I_{SENSE} , differentiation of the contents of the accumulated charge register (ACR) over time may be used to measure average current.

Accuracy of such an indirect current measurement is limited by the basic accuracy of the coulomb counter, the accuracy of the timebase within the host system, quantization caused by the prescaler setting, and time delays caused by I²C transactions. Still, especially at higher currents, useful results may be obtained by reading the accumulated charge register twice, with a defined time interval in between, and dividing the charge difference by the time interval. The time interval may be increased at low currents to limit time quantization errors to the desired accuracy. For quicker current measurements at low currents, prescale factor M may be temporarily decreased, sacrificing some coulomb count accuracy for higher current resolution.

Extending Coulomb Counter Range

To increase the range of the coulomb counter for battery capacities higher than 5.5Ah, the host controller can either regularly poll the accumulated charge register (ACR) or use

the threshold registers to determine when the accumulated charge register approaches the minimum or maximum limits. At this point it can add or subtract a fixed charge quantity and rewrite the result into the ACR. The added or subtracted charge quantities can then be tracked in software, increasing the effective ACR range.

PC Board Layout Suggestions

Keep all traces as short as possible to minimize noise and inaccuracy. Use wider traces from the resistor to the battery, load and/or charger (see Figure 11). Put the bypass capacitor close to SENSE+ and GND. Provide adequate copper area on exposed pad for heat sinking.

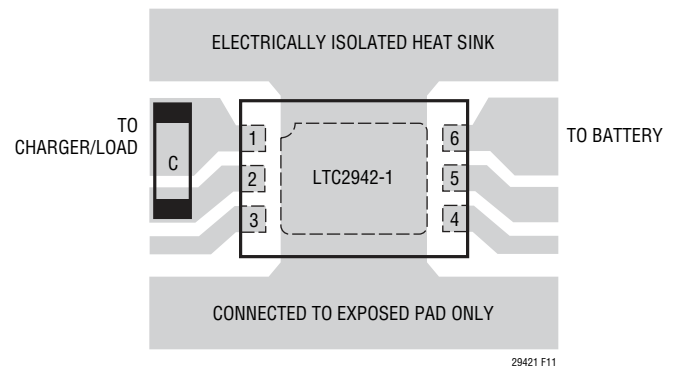
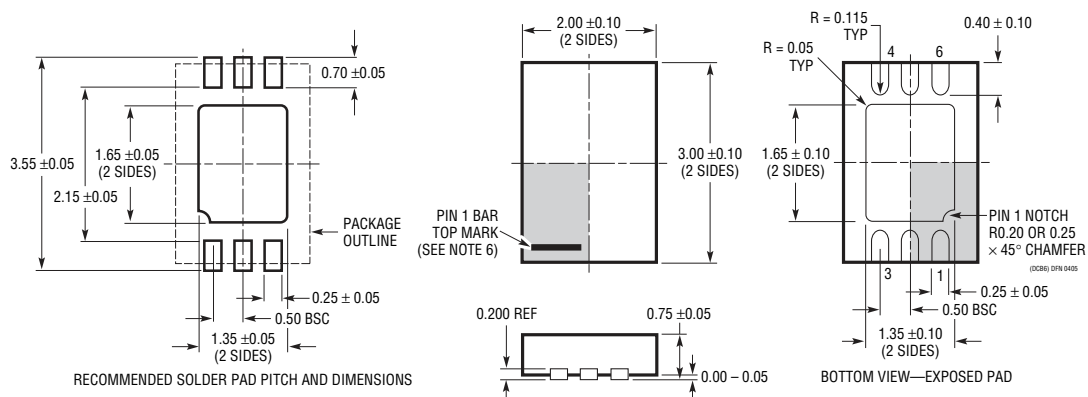

Figure 11. Recommended Layout

PACKAGE DESCRIPTION

DCB Package 6-Lead Plastic DFN (2mm × 3mm) (Reference LTC DWG # 05-08-1715)



- NOTE:
1. DRAWING TO BE MADE A JEDEC PACKAGE OUTLINE MO-229 VARIATION OF (TBD)
 2. DRAWING NOT TO SCALE
 3. ALL DIMENSIONS ARE IN MILLIMETERS

4. DIMENSIONS OF EXPOSED PAD ON BOTTOM OF PACKAGE DO NOT INCLUDE MOLD FLASH. MOLD FLASH, IF PRESENT, SHALL NOT EXCEED 0.15mm ON ANY SIDE
5. EXPOSED PAD SHALL BE SOLDER PLATED
6. SHADED AREA IS ONLY A REFERENCE FOR PIN 1 LOCATION ON THE TOP AND BOTTOM OF PACKAGE

TYPICAL APPLICATION

Single Cell Lithium-Ion Coulomb Counter with Battery Charger for Discharge Currents of up to 1A

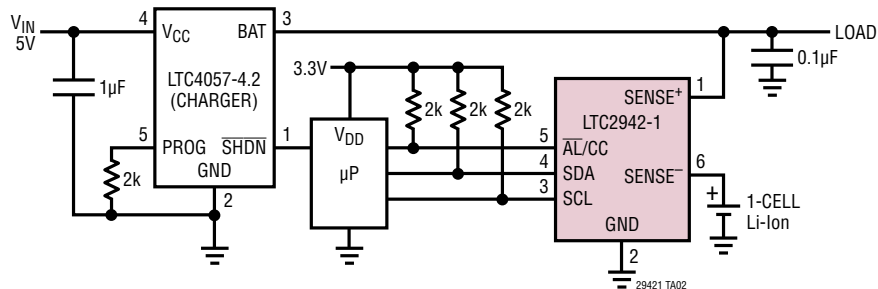

RELATED PARTS

PART NUMBER	DESCRIPTION	COMMENTS
Battery Gas Gauges		
LTC2942	Battery Gas Gauge with I ² C Interface and Voltage and Temperature ADC	2.7V to 5.5V Operation, 14-Bit $\Delta\Sigma$ -ADC, Pin Compatible with LTC2941
LTC2941	Battery Gas Gauge with I ² C Interface	2.7V to 5.5V Operation, Pin Compatible with LTC2942
LTC2941-1	Battery Gas Gauge with I ² C Interface and Integrated 50m Ω Sense Resistor	2.7V to 5.5V Operation, Pin Compatible with LTC2942-1
LTC4150	Coulomb Counter/Battery Gas Gauge	2.7V to 8.5V Operation, 10-Pin MSOP Package
Battery Chargers		
LTC1734	Lithium-Ion Battery Charger in ThinSOT™	Simple ThinSOT Charger, No Blocking Diode, No Sense Resistor Needed
LTC4002	Switch Mode Lithium-Ion Battery Charger	Standalone, 4.7V \leq V _{IN} \leq 24V, 500kHz Frequency
LTC4052	Monolithic Lithium-Ion Battery Pulse Charger	No Blocking Diode or External Power FET Required, \leq 1.5A Charge Current
LTC4053	USB Compatible Monolithic Li-Ion Battery Charger	Standalone Charger with Programmable Timer, Up to 1.25A Charge Current
LTC4057	Lithium-Ion Linear Battery Charger	Up to 800mA Charge Current, Thermal Regulation, ThinSOT Package
LTC4058	Standalone 950mA Lithium-Ion Charger in DFN	C/10 Charge Termination, Battery Kelvin Sensing, \pm 7% Charge Accuracy
LTC4059	900mA Linear Lithium-Ion Battery Charger	2mm \times 2mm DFN Package, Thermal Regulation, Charge Current Monitor Output
LTC4061	Standalone Linear Li-Ion Battery Charger with Thermistor Input	4.2V, \pm 0.35% Float Voltage, Up to 1A Charge Current, 3mm \times 3mm DFN Package
LTC4063	Li-Ion Charger with Linear Regulator	Up to 1A Charge Current, 100mA, 125mV LDO, 3mm \times 3mm DFN Package
LTC4088	High Efficiency Battery Charger/USB Power Manager	Maximizes Available Power from USB Port, Bat-Track™, Instant-On Operation, 1.5A Max Charge Current, 180m Ω Ideal Diode with $<$ 50m Ω Option, 3.3V/25mA Always-On LDO, 4mm \times 3mm DFN-14 Package