

THIS DRAWING IS UNPUBLISHED. RELEASED FOR PUBLICATION
 © COPYRIGHT - By - ALL RIGHTS RESERVED.

LOC	DIST	REVISIONS			
P	LTR	DESCRIPTION	DATE	DWN	APVD
GP	00	AC2	REVISED PER ECO-11-004835	11MAR11	RK HMR

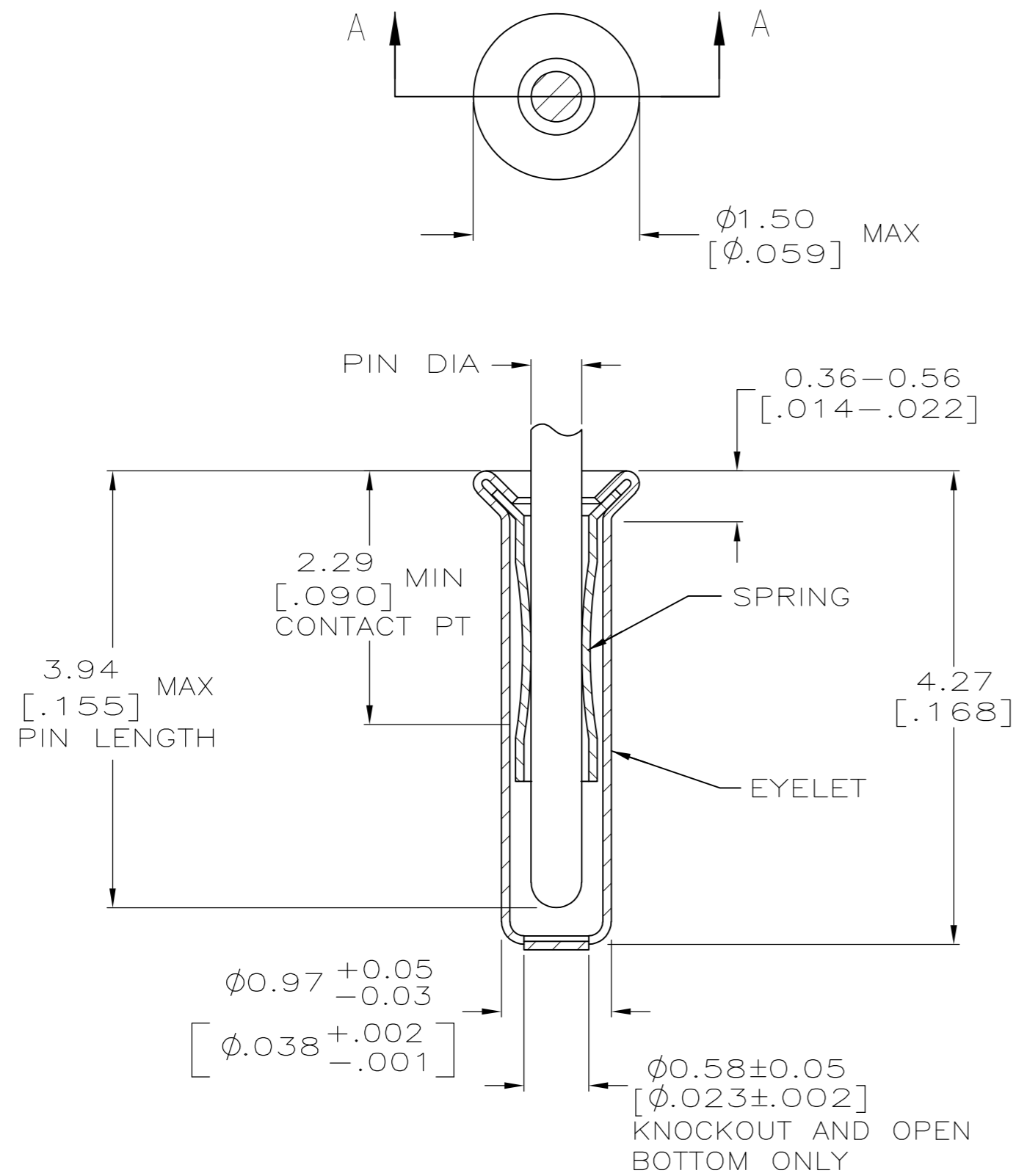

SECTION A-A

- 1. TIN PER MIL-T-10727 OR TIN LEAD .000254 [.000100] MIN THK.
- 2. GOLD PER MIL-G-45204, TYPE II, 0.00076 [.000030] MIN THK OVER NICKEL PER QQ-N-290 0.00028 [.000011] MIN THK ON CONTACT AREA.
- 3. GOLD FLASH PER MIL-G-45204, TYPE II, 0.13µm [.000005] MIN THK. OVER NICKEL PLATE PER QQ-N-290 0.51µm-1.52µm [.000020-.000060] EXT THK.
- 4. RECOMMENDED HOLE SIZE, PLATED OR UNPLATED:
 MACHINE INSERTION: 1.04±0.05 [.041±.002]
 HAND INSERTION: 1.02 +0.10/-0.00 [.040 +.004/-0.000]
- 5. APPLICATION TOOL PART NUMBER:
 MACHINE NO. 682127-2
 INSERTION HEAD NO. 682039-1
- 6. TO INSURE PROPER SPRING TENSION DO NOT EXCEED A 0.10 [.004] DIFFERENCE IN PIN DIA WHEN CHANGING TO A SMALLER PIN.
- 7. BOTTOM PLUG KNOCKOUT TOOL PART NUMBER 69729 WITH TIP PART NUMBER 69728.
- 8. TIN PER ASTM B 545, .000254 [.000100] MIN THK.

SUPSD BY 50935-1	CLOSED	0.33-0.51 [.013-.020]	TIN 8	TIN 8	6-50935-2
	OPEN		TIN 1	GOLD 2	50935-9
OBSOLETE OBSOLETE OBSOLETE	KNOCKOUT	0.33-0.51 [.013-.020]	GOLD 3	TIN 1	50935-8
	CLOSED		TIN 1	GOLD 2	50935-6
			TIN 1	TIN 1	50935-5
BOTTOM TYPE	RECOMMENDED PIN DIA 6	TIN 1	GOLD 2	50935-4	
			TIN 1	TIN 1	50935-2
			GOLD 3	GOLD 2	50935-1
			GOLD 3	GOLD 2	50935
			EYELET	SPRING	PART NO
			FINISH		

THIS DRAWING IS A CONTROLLED DOCUMENT.		DWN	20SEP2005	TE Connectivity	
DIMENSIONS: INCHES		CHK	R. TALLEY	MINIATURE SPRING SOCKET ASSEMBLY SERIES 1	
TOLERANCES UNLESS OTHERWISE SPECIFIED:		APVD	-	-	
0 PLC ± -		PRODUCT SPEC	-	-	
1 PLC ± -		APPLICATION SPEC	-	-	
2 PLC ± -		WEIGHT	-	-	
3 PLC ± 0.20 [.008]		SCALE	20:1	SHEET 1 of 1	
4 PLC ± -		CUSTOMER DRAWING	-	REV AC2	
ANGLES ± -					
MATERIAL BE CU					
FINISH -					