

DESCRIPTION

The EV3412EJ-00A is an evaluation board for the MP3412, a synchronous step-up WLED driver with true output load disconnection function. The EV board is designed for driving one WLED.

The MP3412 can startup from an input voltage as low as 0.8V and provides in-rush current limiting as well as output short circuit protection. The open load protection is also integrated

A switching frequency of 1MHz minimizes overall solution footprint by allowing the use of tiny, low profile inductors and ceramic capacitors. Current mode PWM control with internal compensation reduces external parts, thereby saving critical board space.

The device also features low shutdown current of under 1 μ A. The true output disconnect feature allows the output to be completely discharged in shutdown. It also limits the inrush of current during start-up, minimizing surge current seen by the input supply.

The MP3412 is available in 6-pin thin SOT23 package.

FEATURES

- Input Range: 0.8V to 4.4V
- 0.8V Low Start-Up Voltage
- Internal Power MOSFET and Synchronous Rectifier
- 1MHz Fixed Switching Frequency
- Up to 96% Efficiency
- True Output Load Disconnect
- Open-Load Protection
- Short-Circuit Protection
- Fully Assembled and Tested

APPLICATIONS

- Cellular Phones
- Digital Cameras
- Handheld Instruments
- Wireless Handsets
- GPS Receivers

ELECTRICAL SPECIFICATIONS

Parameter	Symbol	Value	Units
Input Voltage	V_{IN}	0.8~4.4	V
# of WLEDs		1	
LED Current	I_{LED}	200	mA

"MPS" and "The Future of Analog IC Technology" are Registered Trademarks of Monolithic Power Systems, Inc.

EV3412EJ-00A EVALUATION BOARD



(L x W x H) 2.0" x 2.0" x 0.4"
5.0cm x 5.0cm x 1.0cm

Board Number	MPS IC Number
EV3412EJ-00A	MP3412EJ

Efficiency

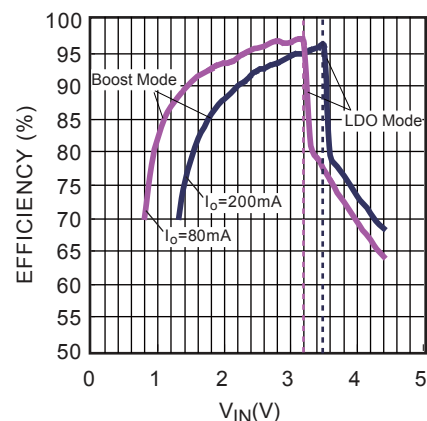

EVALUATION BOARD SCHEMATIC

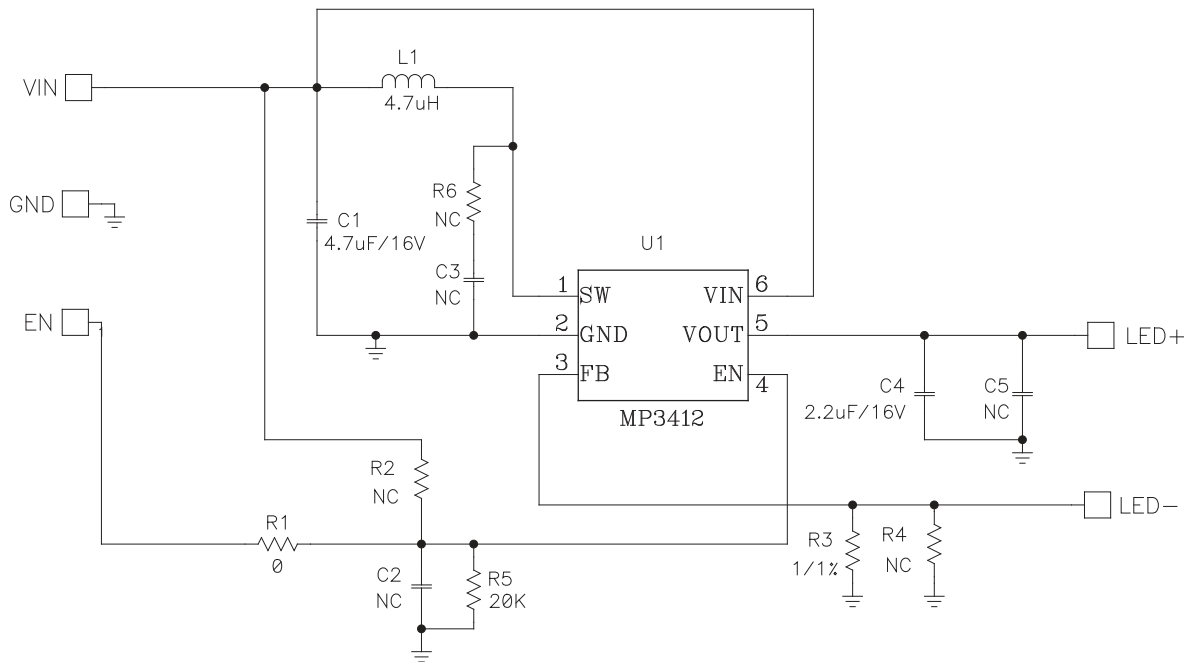

EV3412EJ-00A BILL OF MATERIALS

Qty	Ref	Value	Description	Package	Manufacturer	Part Number
1	C1	4.7µF	Ceramic Capacitor, 16V, X7R	1206	muRata	GRM31CR71C475KA01L
3	C2, C3, C5	NC				
1	C4	2.2µF	Ceramic Capacitor, 16V, X7R	0805	muRata	GRM21BR71C225KA12L
1	L1	4.7µH	Inductor 1.36A	D63LCB	TOKO	#A921CY-4R7M=P3
1	R1	0Ω	5%	0603	Any	
3	R2, R4, R6	NC				
1	R3	1Ω	1%	0805	Yageo	RC0805FR-071RL
1	R5	20kΩ	5%	0603	Any	
1	U1	MP3412EJ	MPS WLED Driver	TSOT23-6	MPS	MP3412EJ-LF-Z R1

PRINTED CIRCUIT BOARD LAYOUT



Figure 1—Top Layer

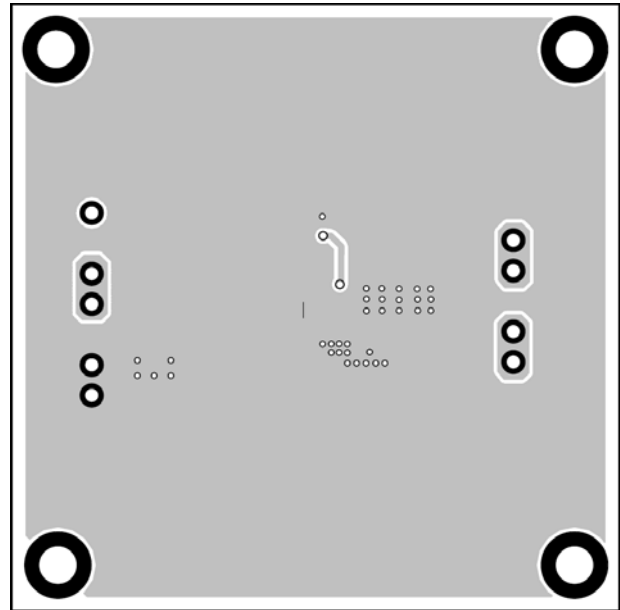

Figure 2—Bottom Layer

QUICK START GUIDE

1. Connect the positive and negative terminals of one WLED to the LED+ and LED- pins on the EV board, respectively.
2. Connect the positive and negative terminals of the power supply to the VIN and GND pins on the EV board, respectively. Turn the power supply on.
3. Drive EN pin high ($V_{EN} > 0.8V$) to enable the MP3412.
4. For PWM dimming mode, apply a PWM signal with high level greater than 0.8V to the EN pin. The typical PWM frequency should be 200Hz. The WLED brightness can be controlled by the PWM dimming duty cycle.

NOTICE: The information in this document is subject to change without notice. Users should warrant and guarantee that third party Intellectual Property rights are not infringed upon when integrating MPS products into any application. MPS will not assume any legal responsibility for any said applications.