

KA337 / LM337

3-Terminal 1.5 A Negative Adjustable Regulator

Features

- Output-Current in Excess of 1.5 A
- Output-Adjustable Between -1.25 V and -37 V
- Internal Thermal Overload Protection
- Internal Short-Circuit Current Limiting
- Output-Transistor Safe Area Compensation
- Floating Operation for High-Voltage Applications
- Standard 3-Pin TO-220 Package

Description

The KA337 / LM337 are 3-terminal negative adjustable regulators. They supply in excess of 1.5 A over an output voltage range of -1.25 V to -37 V. These regulators require only two external resistors to set the output voltage and employ current limiting, thermal overload protection, and safe area compensation.

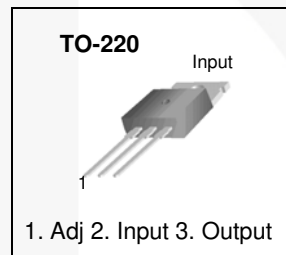

Ordering Information

Product Number	Package	Packing Method	Operating Temperature
KA337TU	TO-220 (Dual Gauge)	Rail	0°C to +125°C
LM337T	TO-220 (Single Gauge)		

Block Diagram

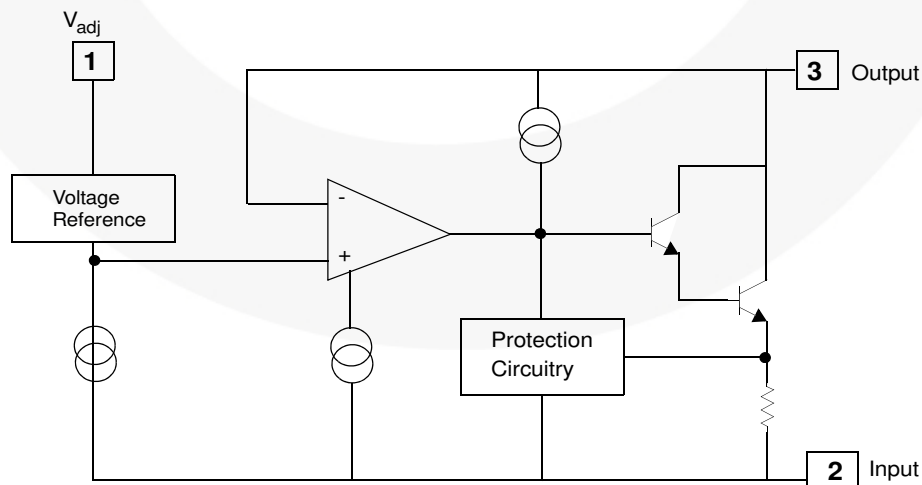

Figure 1. Block Diagram

Absolute Maximum Ratings

Stresses exceeding the absolute maximum ratings may damage the device. The device may not function or be operable above the recommended operating conditions and stressing the parts to these levels is not recommended. In addition, extended exposure to stresses above the recommended operating conditions may affect device reliability. The absolute maximum ratings are stress ratings only. Values are at $T_A = 25^\circ\text{C}$ unless otherwise noted.

Symbol	Parameter	Value	Unit
$ V_I - V_O $	Input-Output Voltage Differential	40	V
P_D	Power Dissipation	Internally Limited	W
$R_{\theta JC}$	Thermal Resistance, Junction to Case	4	$^\circ\text{C}/\text{W}$
T_{OPR}	Operating Temperature Range	0 to +125	$^\circ\text{C}$
T_{STG}	Storage Temperature Range	-65 to +125	$^\circ\text{C}$

Electrical Characteristics

$V_I - V_O = 5\text{ V}$, $I_O = 40\text{ mA}$, $0^\circ\text{C} \leq T_J \leq +125^\circ\text{C}$, $P_{D\text{MAX}} = 20\text{ W}$; unless otherwise specified.

Symbol	Parameter	Conditions	Min.	Typ.	Max.	Unit
R_{line}	Line Regulation ⁽¹⁾	$T_A = +25^\circ\text{C}$, $3\text{ V} \leq V_I - V_O \leq 40\text{ V}$		0.01	0.04	% / V
		$3\text{ V} \leq V_I - V_O \leq 40\text{ V}$		0.02	0.07	
R_{load}	Load Regulation ⁽¹⁾	$T_A = +25^\circ\text{C}$, $10\text{ mA} \leq I_O \leq 0.5\text{ A}$		15	50	mV
		$10\text{ mA} \leq I_O \leq 1.5\text{ A}$		15	150	
I_{ADJ}	Adjustable Pin Current			50	100	μA
ΔI_{ADJ}	Adjustable Pin Current Change	$T_A = +25^\circ\text{C}$, $10\text{ mA} \leq I_O \leq 1.5\text{ A}$, $3\text{ V} \leq V_I - V_O \leq 40\text{ V}$		2	5	μA
V_{REF}	Reference Voltage	$T_A = +25^\circ\text{C}$	-1.213	-1.250	-1.287	V
		$3\text{ V} \leq V_I - V_O \leq 40\text{ V}$, $10\text{ mA} \leq I_O \leq 1.5\text{ A}$	-1.200	-1.250	-1.300	
ST_T	Temperature Stability	$0^\circ\text{C} \leq T_J \leq +125^\circ\text{C}$		0.6		%
$I_{L(MIN)}$	Minimum Load Current to Maintain Regulation	$3\text{ V} \leq V_I - V_O \leq 40\text{ V}$		2.5	10.0	mA
		$3\text{ V} \leq V_I - V_O \leq 10\text{ V}$		1.5	6.0	
e_N	RMS Noise, % of V_{OUT}	$T_A = +25^\circ\text{C}$, $10\text{ Hz} \leq f \leq 10\text{ kHz}$		0.003		%
RR	Ripple Rejection Ratio	$V_O = -10\text{ V}$, $f = 120\text{ Hz}$		60		dB
		$C_{ADJ} = 10\text{ }\mu\text{F}^{(2)}$	66	77		
ST	Long-Term Stability	$T_J = 125^\circ\text{C}$, 1000 Hours		0.3	1.0	%

Notes:

1. Load and line regulation are specified at constant junction temperature. Change in V_O due to heating effects must be taken into account separately. Pulse testing with low duty is used.
2. C_{ADJ} , when used, is connected between the adjustment pin and ground.

Typical Performance Characteristics

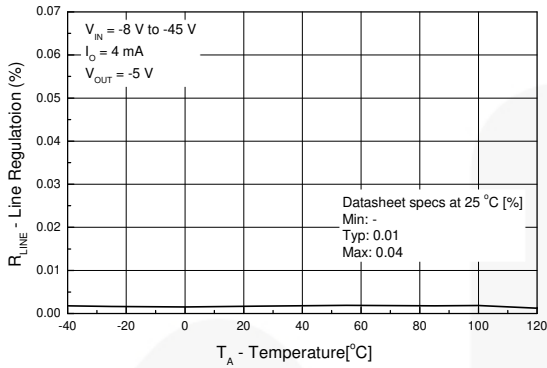

Figure 2. Line Regulation vs. Temperature

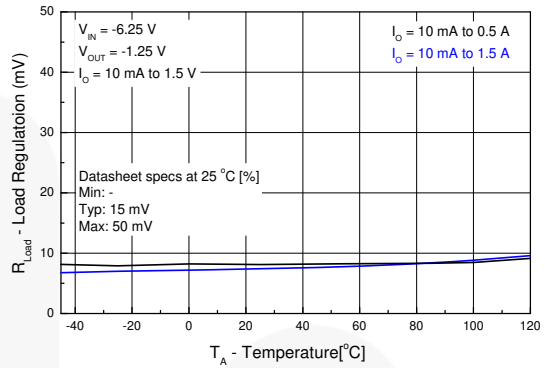

Figure 3. Load Regulations vs. Temperature

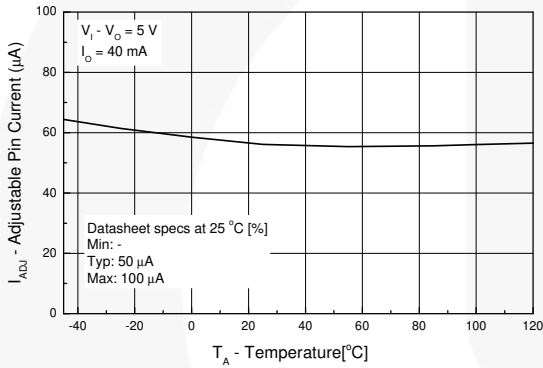

Figure 4. Adjustable Pin Current vs. Temperature

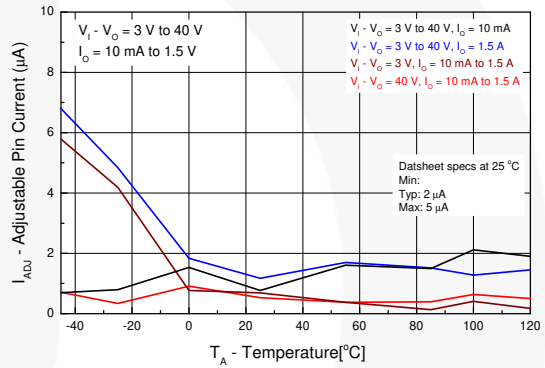

Figure 5. Adjustable Pin Current Change vs. Temperature

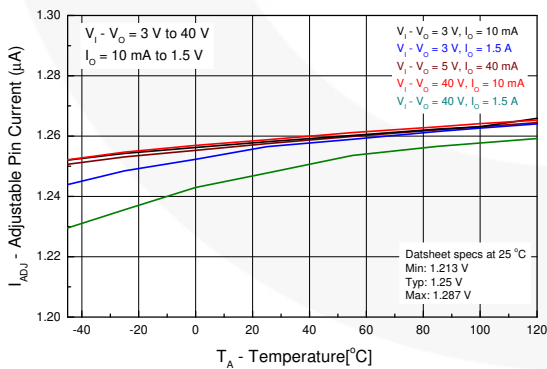

Figure 6. Reference Voltage vs. Temperature

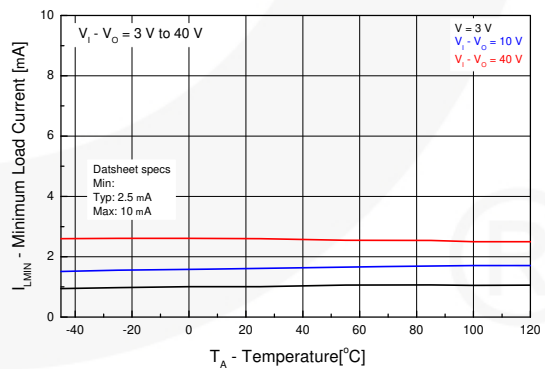

Figure 7. Minimum Load Current vs. Temperature

Typical Performance Characteristics

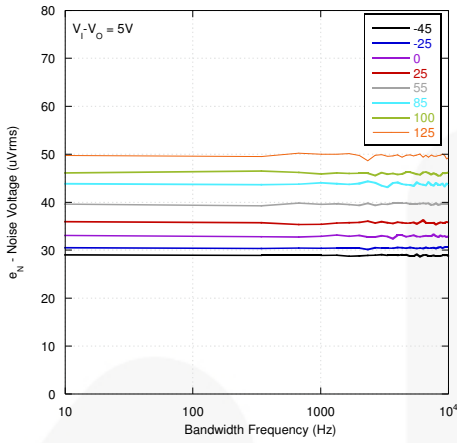

Figure 8. Noise Voltage vs. Temperature

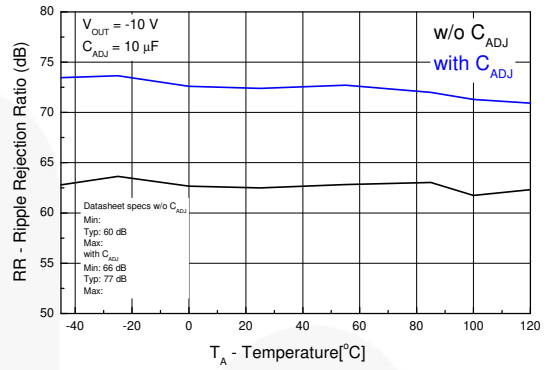

Figure 9. Ripple Rejection vs. Temperature

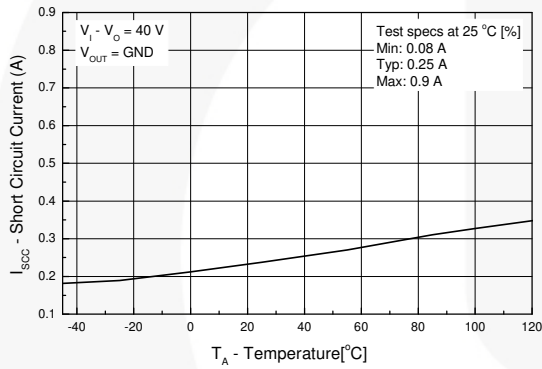

Figure 10. Short-Circuit Currents vs. Temperature

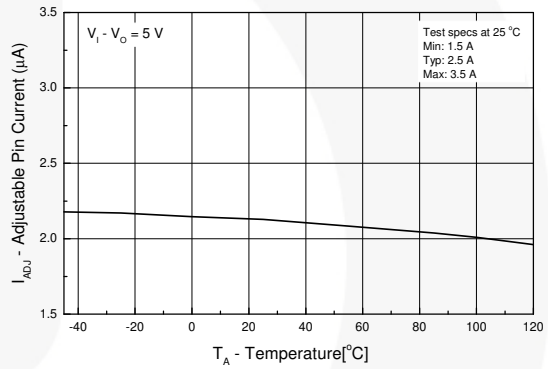

Figure 11. Peak Current vs. Temperature

Typical Application

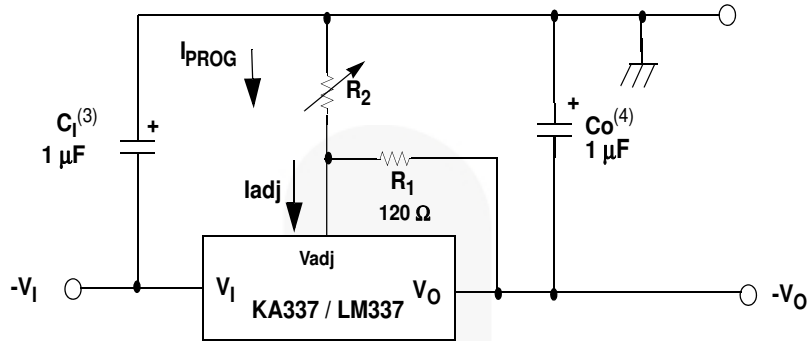

Figure 12. Typical Application

Notes:

- 3. C_1 is required if regulator is located more than 4 inches from power supply filter. 1.0 μF solid tantalum or 10 μF aluminum electrolytic is recommended.
 - 4. C_0 is necessary for stability. 1.0 μF solid tantalum or 10 μF aluminum electrolytic is recommended.
- $V_0 = -1.25 \text{ V} (1 + R_2 / R_1)$.

Physical Dimensions

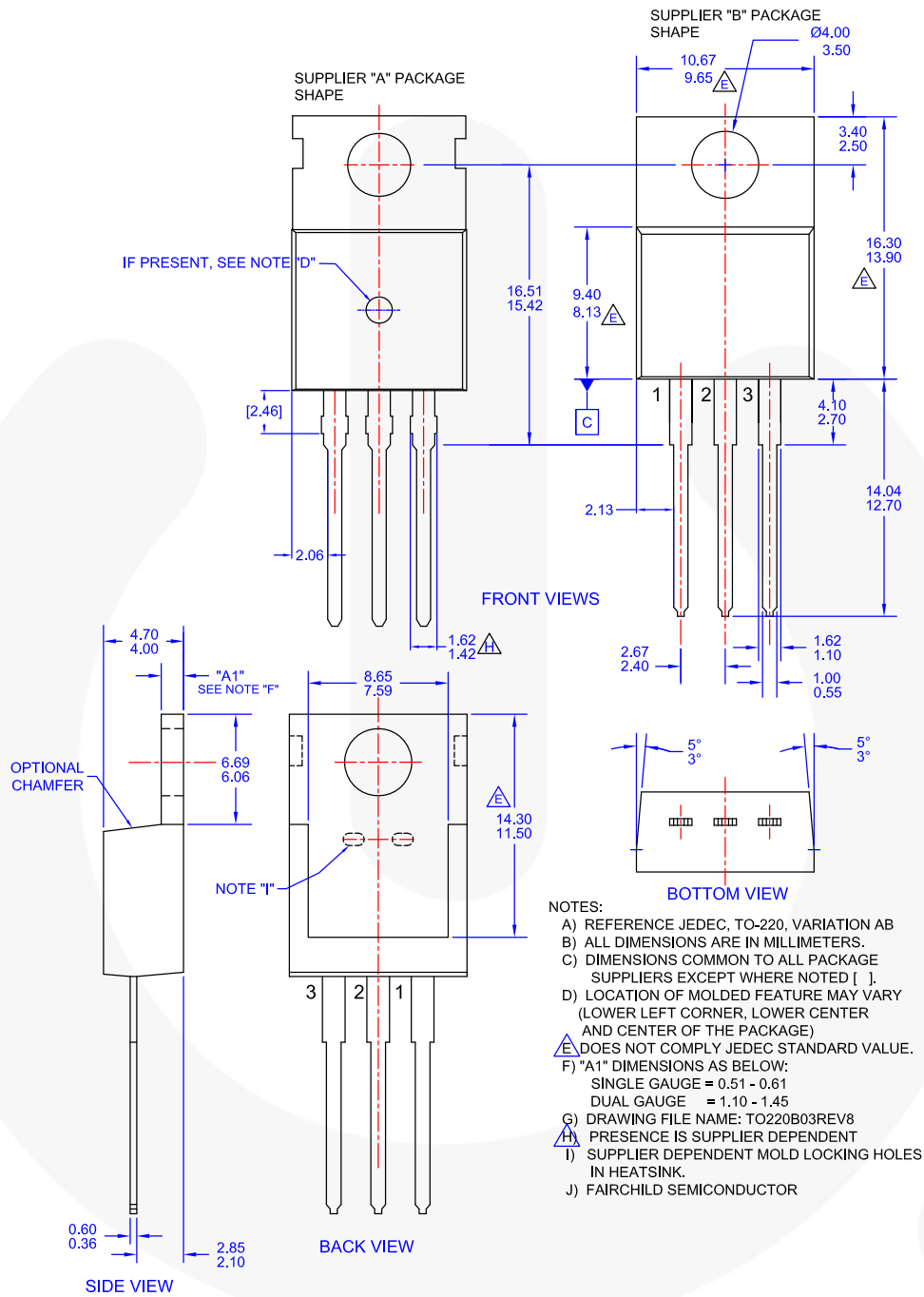

Figure 13. TO-220, MOLDED, 3LEAD, JEDEC VARIATION AB



TRADEMARKS

The following includes registered and unregistered trademarks and service marks, owned by Fairchild Semiconductor and/or its global subsidiaries, and is not intended to be an exhaustive list of all such trademarks.

AccuPower™	F-PFST™		
Awinda®	FRFET®	PowerTrench®	TinyBoost®
AX-CAP®*	Global Power Resource™	PowerXS™	TinyBuck®
BitSiC™	GreenBridge™	Programmable Active Droop™	TinyCalc™
Build it Now™	Green FPS™	QFET®	TinyLogic®
CorePLUS™	Green FPS™ e-Series™	QS™	TINYOPTO™
CorePOWER™	Gmax™	Quiet Series™	TinyPower™
CROSSVOLT™	GTO™	RapidConfigure™	TinyPWM™
CTL™	IntelliMAX™		TinyWire™
Current Transfer Logic™	ISOPLANAR™	Saving our world, 1mW/W/kW at a time™	TranSiC™
DEUXPEED®	Making Small Speakers Sound Louder and Better™	SignalWise™	TriFault Detect™
Dual Cool™	MegaBuck™	SmartMax™	TRUECURRENT®*
EcoSPARK®	MICROCOUPLER™	SMART START™	µSerDes™
EfficientMax™	MicroFET™	Solutions for Your Success™	
ESBC™	MicroPak™	SPM®	UHC®
	MicroPak2™	STEALTH™	Ultra FRFET™
Fairchild®	MillerDrive™	SuperFET®	UniFET™
Fairchild Semiconductor®	MotionMax™	SuperSOT™-3	VCX™
FACT Quiet Series™	MotionGrid®	SuperSOT™-6	VisualMax™
FACT®	MTi®	SuperSOT™-8	VoltagePlus™
FAST®	MTx®	SupreMOS®	XS™
FastvCore™	MVN®	SyncFET™	Xsens™
FETBench™	mWSaver®	Sync-Lock™	仙童™
FPS™	OptoHiT™		

* Trademarks of System General Corporation, used under license by Fairchild Semiconductor.

DISCLAIMER

FAIRCHILD SEMICONDUCTOR RESERVES THE RIGHT TO MAKE CHANGES WITHOUT FURTHER NOTICE TO ANY PRODUCTS HEREIN TO IMPROVE RELIABILITY, FUNCTION, OR DESIGN. TO OBTAIN THE LATEST, MOST UP-TO-DATE DATASHEET AND PRODUCT INFORMATION, VISIT OUR WEBSITE AT [HTTP://WWW.FAIRCHILDSEMI.COM](http://www.fairchildsemi.com). FAIRCHILD DOES NOT ASSUME ANY LIABILITY ARISING OUT OF THE APPLICATION OR USE OF ANY PRODUCT OR CIRCUIT DESCRIBED HEREIN; NEITHER DOES IT CONVEY ANY LICENSE UNDER ITS PATENT RIGHTS, NOR THE RIGHTS OF OTHERS. THESE SPECIFICATIONS DO NOT EXPAND THE TERMS OF FAIRCHILD'S WORLDWIDE TERMS AND CONDITIONS, SPECIFICALLY THE WARRANTY THEREIN, WHICH COVERS THESE PRODUCTS.

LIFE SUPPORT POLICY

FAIRCHILD'S PRODUCTS ARE NOT AUTHORIZED FOR USE AS CRITICAL COMPONENTS IN LIFE SUPPORT DEVICES OR SYSTEMS WITHOUT THE EXPRESS WRITTEN APPROVAL OF FAIRCHILD SEMICONDUCTOR CORPORATION.

As used herein:

1. Life support devices or systems are devices or systems which, (a) are intended for surgical implant into the body or (b) support or sustain life, and (c) whose failure to perform when properly used in accordance with instructions for use provided in the labeling, can be reasonably expected to result in a significant injury of the user.
2. A critical component in any component of a life support, device, or system whose failure to perform can be reasonably expected to cause the failure of the life support device or system, or to affect its safety or effectiveness.

ANTI-COUNTERFEITING POLICY

Fairchild Semiconductor Corporation's Anti-Counterfeiting Policy. Fairchild's Anti-Counterfeiting Policy is also stated on our external website, www.fairchildsemi.com, under Sales Support.

Counterfeiting of semiconductor parts is a growing problem in the industry. All manufacturers of semiconductor products are experiencing counterfeiting of their parts. Customers who inadvertently purchase counterfeit parts experience many problems such as loss of brand reputation, substandard performance, failed applications, and increased cost of production and manufacturing delays. Fairchild is taking strong measures to protect ourselves and our customers from the proliferation of counterfeit parts. Fairchild strongly encourages customers to purchase Fairchild parts either directly from Fairchild or from Authorized Fairchild Distributors who are listed by country on our web page cited above. Products customers buy either from Fairchild directly or from Authorized Fairchild Distributors are genuine parts, have full traceability, meet Fairchild's quality standards for handling and storage and provide access to Fairchild's full range of up-to-date technical and product information. Fairchild and our Authorized Distributors will stand behind all warranties and will appropriately address any warranty issues that may arise. Fairchild will not provide any warranty coverage or other assistance for parts bought from Unauthorized Sources. Fairchild is committed to combat this global problem and encourage our customers to do their part in stopping this practice by buying direct or from authorized distributors.

PRODUCT STATUS DEFINITIONS

Definition of Terms

Datasheet Identification	Product Status	Definition
Advance Information	Formative / In Design	Datasheet contains the design specifications for product development. Specifications may change in any manner without notice.
Preliminary	First Production	Datasheet contains preliminary data; supplementary data will be published at a later date. Fairchild Semiconductor reserves the right to make changes at any time without notice to improve design.
No Identification Needed	Full Production	Datasheet contains final specifications. Fairchild Semiconductor reserves the right to make changes at any time without notice to improve the design.
Obsolete	Not In Production	Datasheet contains specifications on a product that is discontinued by Fairchild Semiconductor. The datasheet is for reference information only.