

# TMS570LC43x Hercules Development Kit (HDK)

## User's Guide



Literature Number: SPNU597A  
May 2014–Revised November 2018

<b>Preface</b> .....	<b>4</b>
<b>1 Introduction</b> .....	<b>5</b>
1.1 Scope of Document .....	5
1.2 TMS570LC43 HERCULES Development Kit (HDK) Features.....	5
1.3 HDK Board Block Diagram .....	6
1.4 TMS570LC43 HDK Contents .....	6
1.5 HDK Specifications .....	7
1.6 Basic Operation .....	7
1.7 Memory Map .....	7
1.8 Power Supply.....	7
<b>2 Physical Description</b> .....	<b>9</b>
2.1 Board Layout .....	9
2.2 Connectors .....	10
2.2.1 20-Pin ARM JTAG Header .....	11
2.2.2 Ethernet Interface .....	11
2.2.3 CAN Interface.....	11
2.2.4 J19, MIPI ETM Connector.....	13
2.2.5 J7, XDS100V2 USB JTAG Interface.....	15
2.2.6 P1, +5 V to +12 V Input .....	15
2.2.7 SCI Interface .....	15
2.2.8 Daughter Card Interface.....	15
2.3 LEDs .....	19
2.4 S2 DIP Switch .....	19
2.5 Jumpers .....	20
2.6 S4, Power On Reset Switch .....	20
2.7 S3, System Reset Switch .....	20
<b>A Operation Notices</b> .....	<b>21</b>
A.1 Operation Notices .....	21
<b>Revision History</b> .....	<b>22</b>

## List of Figures

1-1.	TMS570LC43 HDK Board Block Diagram.....	6
2-1.	TMS570LC43 HDK Board, Interfaces Top Side .....	9
2-2.	Connectors on TMS570LC43 HDK .....	10
2-3.	CAN Bus Termination.....	12
2-4.	J2, J3 CAN Bus Interface (Screw Terminal) .....	12
2-5.	J19, 60 Pin MIPI ETM Header.....	13
2-6.	+12 V Input Jack .....	15
2-7.	J9, J10, and J11 on HDK .....	16
2-8.	DIP Switch Settings .....	19

## List of Tables

1-1.	TMS570LC43 Memory Map .....	7
1-2.	Power Test Points .....	8
2-1.	Connectors on HDK Board.....	10
2-2.	20-Pin ARM JTAG Header .....	11
2-3.	J1, Ethernet Interface .....	11
2-4.	J19, MIPI Connector Signal Mapping.....	13
2-5.	J19, MIPI Connector Signal Mapping.....	14
2-6.	J7, XDS100V2 USB JTAG Interface.....	15
2-7.	Expansion Connector P1 (J9, Left, BottomView) .....	16
2-8.	Expansion Connector P2 (J10, Right, BottomView) .....	17
2-9.	Expansion Connector P3 (J11, Bottom One, TopView) .....	18
2-10.	Demo LEDs .....	19
2-11.	Other LEDs as Indicator .....	19
2-12.	S2 DIP Switch Functions .....	20
2-13.	Jumpers .....	20

---

---

## Read This First

---

---

### Trademarks

Hercules, Code Composer Studio are trademarks of Texas Instruments.  
ARM is a registered trademark of ARM Limited.  
All other trademarks are the property of their respective owners.

### About This Manual

This document describes the board level operations of the TMS570LC43 Hercules™ Development Kit (HDK). The HDK is based on the Texas Instruments TMS570LC4357 Microcontroller. The TMS570LC43 HDK is a table top card that allows engineers and software developers to evaluate certain characteristics of the TMS570LC4357 microcontroller to determine if the microcontroller meets the designer's application requirements as well as begin early application development. Evaluators can create software to execute on board or expand the system in a variety of ways.

### Notational Conventions

This document uses the following conventions.

The TMS570LC43 HDK will sometimes be referred to as the HDK.

Program listings, program examples, and interactive displays are shown in a special italic typeface. Here is a sample program listing:

- equations
- !rd = !strobe&rw

### Information About Cautions

This book may contain cautions.

***This is an example of a caution statement.***

A caution statement describes a situation that could potentially damage your software, or hardware, or other equipment. The information in a caution is provided for your protection. Please read each caution carefully.

### Related Documentation From Texas Instruments

Information regarding this device can be found at the following Texas Instruments website:  
<http://www.ti.com/product/tms570lc4357>

## Introduction

---

---

---

This development kit provides a product-ready hardware and software platform for evaluating the functionality of the Texas Instruments TMS570LC43 microcontroller family. Schematics, list of materials, and PCB layout are available to ease hardware development and reduce time to market.

### 1.1 Scope of Document

This user's guide lists the contents of the development kit, points out the features of the major components, and provides the instructions necessary to verify your development kit is in working order. Any additional usage instructions or details fall outside the scope of this document. Additional resources will be listed at the end of this user's guide.

### 1.2 TMS570LC43 HERCULES Development Kit (HDK) Features

The HDK comes with a full complement of on board devices that suit a wide variety of application environments. Key features include:

- A Hercules TMS570LC4357 337-pin BGA microcontroller
- Integrated USB JTAG Emulator (XDS100v2)
- External JTAG Headers (ARM® 20 pin and TI Compact 20-pin CTI)
- 10/100 Mbps Ethernet interface
- Two CAN transceivers (SN65HVDA541Q1) and screw terminal blocks
- One ambient light sensor
- One ambient temperature sensor
- Microcontroller's serial communication interface (SCI) universal asynchronous receiver/transmitter (UART) accessible through a USB virtual COM port
- One 8MB SDRAM
- Eight user programmable white LEDs around the MCU silicon
- One user programmable pushbutton
- Three expansion connectors for hardware prototyping
- Reset pushbuttons (nPORRST and nRST)
- One SD card slot (SPI mode)
- Embedded trace macrocell (ETM) debug interface via MIPI connector
- Configurable pin mux options
- 5 V and 3.3 V analog-to-digital converter (ADC) option jumper
- Current measurement capability for 3.3 V IO, 1.2 V core, 1.2 V core, 1.2 V PLL, 3.3 V or 5 V ADC, and 3.3 V  $V_{CCP}$
- Accepts an external power supply between +5V and +12V

### 1.3 HDK Board Block Diagram

Figure 1-1 illustrates the HDK block diagram.

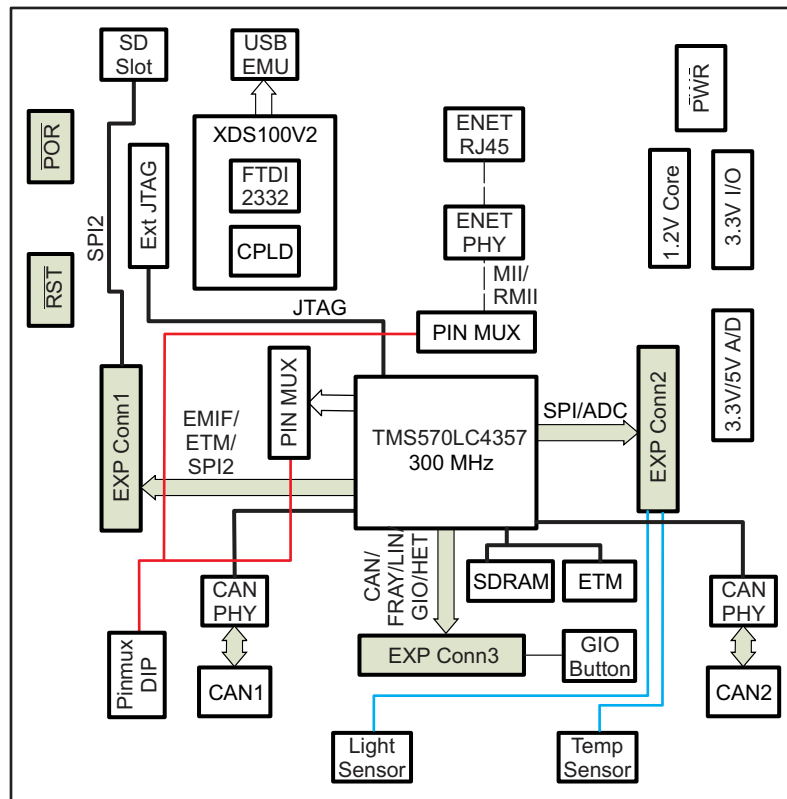

Figure 1-1. TMS570LC43 HDK Board Block Diagram

### 1.4 TMS570LC43 HDK Contents

The kit contains everything needed to develop and run applications for TMS570LC4357 microcontrollers including:

- Board:
  - TMS570LC43 Card
- Cables and Accessories
  - Type A to mini B USB cable for using on board XDS100V2 JTAG emulator
  - Ethernet cable
  - Flashlight for light sensor demo
- CCS DVD Containing:
  - Texas Instruments' Code Composer Studio™ Integrated Development Environments (IDE)
- Hercules DVD Containing:
  - Hercules Safety Demos
  - Hardware Abstraction Layer Code Generator (HALCoGen)
  - Training Videos
  - Device Documentation

Not included:

- 12-V power supply

Below are two options that electrically and mechanically will work with the HDK:

- [QAWA-24-12-US01](#)
  - 12-V output, 2-A max output current
  - Positive center
  - Barrel plug (2.1-mm x 5.5-mm)
  - Output Protection: Short Circuit, Overvoltage, Overcurrent
  - Safety approvals: CB, CE, UL, FCC, PSE, LPS, BSMI, RCM, and CCC
- [SMI24-12-V-P5](#)
  - 12-V output, 2-A max output current
  - Positive center
  - Barrel plug (2.1-mm x 5.5-mm)
  - Output Protection: Short Circuit, Overvoltage, Overcurrent
  - Safety approvals: UL/cUL, CCC, RCM, and PSE

## 1.5 HDK Specifications

- Board supply voltage: 5 V–12 V Vdc
- Dimensions: 4.90" x 4.30" x 0.85" (LxWxH)

## 1.6 Basic Operation

The HDK is designed to work with TI's Code Composer Studio and other third party ARM IDEs. The IDE communicates with the board through the embedded emulator or an external JTAG emulator. To start, follow the instructions in the Quick Start Guide to install Hercules-specific software. This process will install all of the necessary development tools, documentation and drivers.

## 1.7 Memory Map

The TMS570LC43 family of MCUs have a large byte addressable address space. [Table 1-1](#) shows the address space of a TMS570LC4357 microcontroller on the left with specific details of how each region is used by the HDK on the right. By default, the internal memory sits at the beginning of the address space.

The SDRAM is mapped into CS0 space on the EMIF. CS[4:2] are used for synchronous memory for example SRAM, NOR Flash, NAND Flash, and so forth.

To use EMIF, the MPU has to be enabled, and the CS regions have to be configured as "device mode" or "strongly ordered mode" through MPU.

**Table 1-1. TMS570LC43 Memory Map**

Start Address	End Address	HDK
0x0000 0000	0x002F FFFF	Flash
0x0800 0000	0x0803 FFFF	RAM
0x0840 0000	0x0843 FFFF	RAM-ECC
0x6000 0000	0x63FF FFFF	CS2 Async RAM
0x6400 0000	0x67FF FFFF	CS3 Async RAM
0x6800 0000	0x7BFF FFFF	CS4 Async RAM
0x8000 0000	0x87FF FFFF	CS0 Sync SDRAM

## 1.8 Power Supply

The HDK board operates from a single +12 V external power supply connected to the main power input (P1), a 2.5 mm, barrel-type plug. Internally, the +12 V input is converted into +1.2 V, +3.3 V and +5.0 V using Texas Instruments swift voltage regulators and PTH power module. The +1.2 V supply is used for the MCU core while the +3.3 V supply is used for the MCU's I/O buffers and other module on the board. The +5.0 V supply is used for ADC power (second option) and USB VBUS.

There are multiple power test points on the HDK board. The three main test point pairs provide a convenient mechanism to check the HDK's current for each supply. [Table 1-2](#) shows the voltages for each test point and what the supply is used for.

**Table 1-2. Power Test Points**

Test Point Pair	Voltage	Voltage Use
TP14 and TP15	1.2 V	MCU core
TP16 and TP17	3.3 V	MCU IO and logic
TP18 and TP19	1.2 V	MCU PLL
TP20 and TP21	3.3 V	MCU Flash pump
TP22 and TP23	3.3 V or 5.0 V (J8 to enable 5 V)	MCU MibADC, and ADREFHI



## Physical Description

This section describes the physical layout of the TMS570LC43 HDK board and its interfaces.

### 2.1 Board Layout

The TMS570LC43 HDK board is a 4.9 x 4.3 inch (125 x 109 mm) eight layer printed circuit board that is powered by an external +5 V to approximately +12 V only power supply. [Figure 2-1](#) shows the layout of the TMS570LC43 HDK board.



**Figure 2-1. TMS570LC43 HDK Board, Interfaces Top Side**

## 2.2 Connectors

The HDK board has 13 interfaces to various peripherals. These interfaces are described in the following sections.

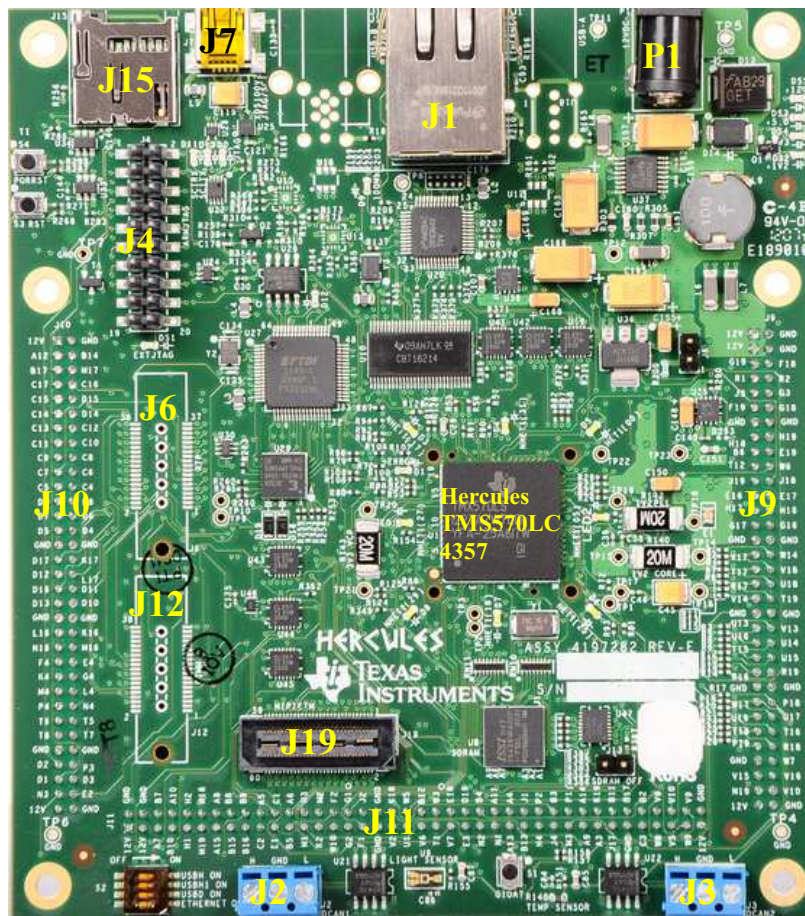

Figure 2-2. Connectors on TMS570LC43 HDK

Table 2-1. Connectors on HDK Board

Connector	Size	Function
J1	RJ45	Ethernet
J2	3 terminal, 2.54mm	DCAN1
J3	3 terminal, 2.54mm	DCAN2
J4	10x2, 2.54mm	ARM 20pin JTAG header
J6	19x2, mictor	RTP
J7	4pin, Mini-B USB	XDS100V2 USB
J9	33x2, 2mm	Exp P1, SPI1, SPI5, ADC
J10	33x2, 2mm	EXP P2, SPI2, EMIF, ECLK
J11	40x2, 2mm	EXP P3, SPI3, GIO, NHET, DCAN, LIN
J12	19x2, mictor	DMM
J15		SD card
J19	30x2, MIPI	ETM MIPI Header
P1	2.5mm	+12 V In

### 2.2.1 20-Pin ARM JTAG Header

In addition to on board XDS100V2 JTAG, one 20-pin ARM JTAG header is added for using external emulator. This is the standard interface used by JTAG emulators to interface to ARM microcontrollers. The pinout for the connector is shown in [Table 2-2](#).

**Table 2-2. 20-Pin ARM JTAG Header**

Signal Name	Pin Number	Pin Number	Signal Name
Vref	1	2	V <sub>CC</sub>
nTRST	3	4	GND
TDI	5	6	GND
TMS	7	8	GND
TCK	9	10	GND
RTCK	11	12	GND
TDO	13	14	GND
nRST	15	16	GND
NC	17	18	GND
NC	19	20	GND

### 2.2.2 Ethernet Interface

The TMS570LC4357 integrates an MII/RMII Ethernet MAC on chip. This interface is routed to the on board PHY via CBT switches. The board uses a DP83640 PHY. The interface is isolated and brought out to a RJ-45 connector with integrated magnetics, J1. The pinmux control DIP S2 is used to control the CBT FET switch for RMII, MII or other functions.

The J1 connector is used to provide a 10/100 Mbps Ethernet interface. This is a standard RJ-45 connector. The cable end pinout for the J1 connector is shown in [Table 2-3](#).

**Table 2-3. J1, Ethernet Interface**

Pin Number	Signal	Pin Number	Signal
1	D0+	2	D0-
3	D1-	4	D2+
5	D2-	6	D1-
7	D3+	8	D3-

Two LEDs are embedded into the connector to report link status (green LED) and transmit and receive status of the PHY (yellow LED).

### 2.2.3 CAN Interface

The TMS570LC4357 has up to three DCAN interfaces that provide a high-speed serial interface. Two 3-pin screw terminal blocks, J2, J3, are used to interface to the DCAN bus. The pinouts for this connector are shown in [Figure 2-4](#). H means CAN High (CAN H), and L means CAN Low (CAN L).

CAN Bus termination is used to minimize signal reflection on the bus. ISO-11898 requires that the CAN bus have a nominal characteristic line impedance of 120 Ω. Therefore, the typical terminating resistor value for each end of the bus is 120 Ω. A split termination method is used to help increase EMC performance. Split termination is a concept that is growing in popularity because emission reduction can be achieved very easily. Split termination is a modified standard termination in which the single 120 Ω resistor on each end of the bus is split into two 60 Ω resistors, with a bypass capacitor tied between the resistors and to ground. The two resistors should match as close as possible.



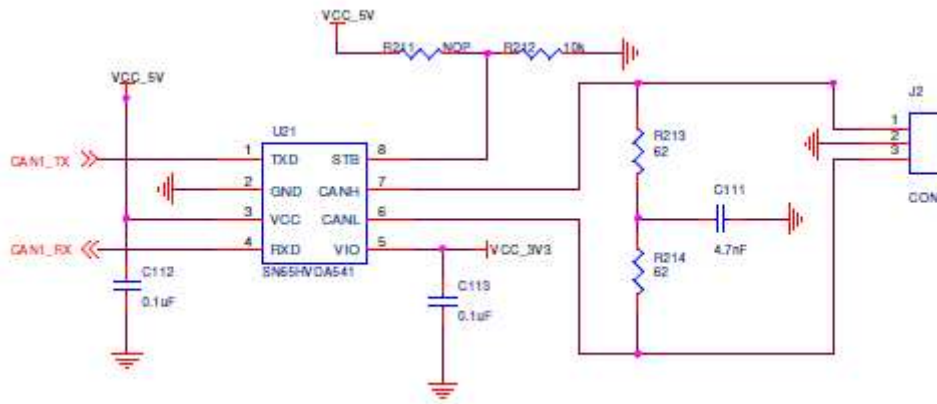

Figure 2-3. CAN Bus Termination

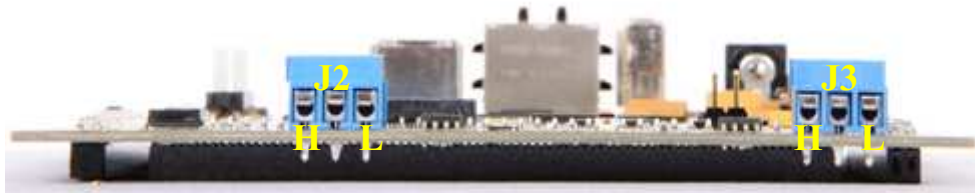
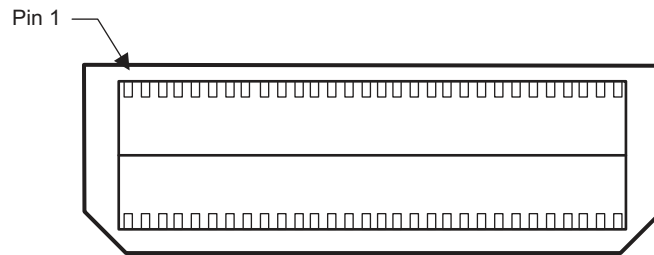

Figure 2-4. J2, J3 CAN Bus Interface (Screw Terminal)

### 2.2.4 J19, MIPI ETM Connector

Figure 2-5 and Table 2-4 show the 60 pin MIPI header.



**Figure 2-5. J19, 60 Pin MIPI ETM Header**

**Table 2-4. J19, MIPI Connector Signal Mapping**

MCU Signals	Pin Number	Pin Number	MCU Signals
3.3 V	1	2	TMS
TCK	3	4	TDO
TDI	5	6	System reset
RTCK	7	8	nTRST
NC	9	10	NC
NC	11	12	3.3 V
NC	13	14	NC
GND	15	16	GND
NC	17	18	NC
NC	19	20	NC
NC	21	22	NC
NC	23	24	NC
NC	25	26	NC
NC	27	28	NC
NC	29	30	NC
NC	31	32	NC
NC	33	34	NC
NC	35	36	NC
NC	37	38	NC
NC	39	40	NC
NC	41	42	NC
NC	43	44	NC
NC	45	46	NC
NC	47	48	NC
NC	49	50	NC
NC	51	52	NC
NC	53	54	NC
NC	55	56	NC
GND	57	58	GND
NC	59	60	NC

**Table 2-5. J19, MIPI Connector Signal Mapping**

MCU Signals	Pin Number	Pin Number	MCU Signals
3.3V	1	2	TMS
TCK	3	4	TDO
TDI	5	6	System reset
RTCK	7	8	nTRST
NC	9	10	NC
NC	11	12	3.3 V
ETMTACECLKOUT	13	14	NC
To GND thru 0 W	15	16	GND
EMTTRACECTL	17	18	ETMDATA[19]
ETMDATA[0]	19	20	ETMDATA[20]
ETMDATA[1]	21	22	ETMDATA[21]
ETMDATA[2]	23	24	ETMDATA[22]
ETMDATA[3]	25	26	ETMDATA[23]
ETMDATA[4]	27	28	ETMDATA[24]
ETMDATA[5]	29	30	ETMDATA[25]
ETMDATA[6]	31	32	ETMDATA[26]
ETMDATA[7]	33	34	ETMDATA[27]
ETMDATA[8]	35	36	ETMDATA[28]
ETMDATA[9]	37	38	ETMDATA[29]
ETMDATA[10]	39	40	ETMDATA[30]
ETMDATA[11]	41	42	ETMDATA[31]
ETMDATA[12]	43	44	NC
ETMDATA[13]	45	46	NC
ETMDATA[14]	47	48	NC
ETMDATA[15]	49	50	NC
ETMDATA[16]	51	52	NC
ETMDATA[17]	53	54	NC
ETMDATA[18]	55	56	NC
GND	57	58	GND
NC	59	60	NC

### 2.2.5 J7, XDS100V2 USB JTAG Interface

The USB connector J7 is used to connect to the host development system that is running the software development IDE, Code Composer Studio. The signals on this connector are shown in [Table 2-6](#).

**Table 2-6. J7, XDS100V2 USB JTAG Interface**

Pin Number	Signal Name
1	USBVDD
2	D-
3	D+
4	NC
5	USBVSS

Before the board is shipped, the XDS100V2 port1 is configured as JTAG, and port2 is configured as SCI. The CPLD on the board is also programmed to route the JTAG signals to the MCU.

There is a circuitry to detect the external JTAG emulator. If a device is plugged onto the header J4 and J19, the DS1 LED will be turned on, and XDS100V2 JTAG is disabled.

### 2.2.6 P1, +5 V to +12 V Input

Connector P1 is the input power connector. This connector brings in +5 V to +12 V to the HDK board. This is a 2.5 mm jack. [Figure 2-6](#) shows this connector as viewed from the card edge.

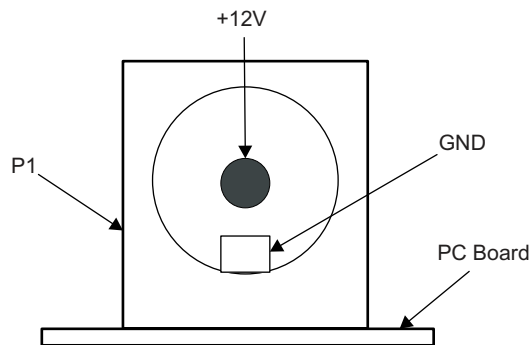

**Figure 2-6. +12 V Input Jack**

### 2.2.7 SCI Interface

The internal SCI on the TMS570LC4357 device is connected to the second port of the XDS100V2. The XDS100V2 USB driver makes the FT2232H second channel appear as a virtual COM port (VCP). This allows the user to communicate with the USB interface via a standard PC serial emulation port.

### 2.2.8 Daughter Card Interface

The HDK provides expansion connectors that can be used to accept plug-in daughter cards. The daughter card allows users to build on their EVM platform to extend its capabilities and provide customer and application specific I/O. The expansion connectors are for all major interfaces including asynchronous memory, peripherals, and A/D expansion.

There are three daughter card interfaces: J9, J10, J11. These connectors are described in [Table 2-7](#).

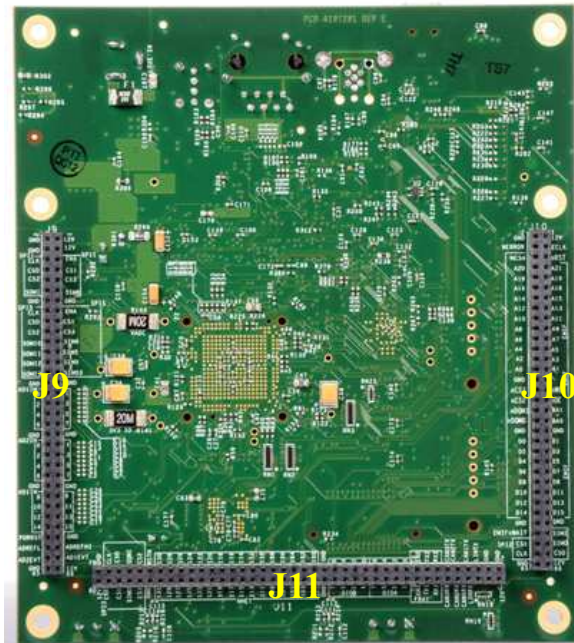
**Figure 2-7. J9, J10, and J11 on HDK**
**Table 2-7. Expansion Connector P1 (J9, Left, BottomView)**

Signal Name	Pin Number	Number	Pin Number	Signal Name	
EXP_12V		1	2	GND	
EXP_12V		3	4	GND	
MibSPI1ENA	G19	5	6	F18	MibSPI1CLK
MibSPI1CS[1]	F3	7	8	R2	MibSPI1CS[0]
MibSPI1CS[3]	J3	9	10	G3	MibSPI1CS[2]
MibSPI1SIMO	F19	11	12	G18	MibSPI1SOMI
GND		13	14		GND
MibSPI5ENA	H18	15	16	H19	MibSPI5CLK
MibSPI5CS[1]	B6	17	18	E19	MibSPI5CS[0]
MibSPI5CS[3]	T12	19	20	W6	MibSPI5CS[2]
MibSPI5SIMO[0]	J19	21	22		MibSPI5SOMI[0]
MibSPI5SIMO[1]	E16	23	24	E17	MibSPI5SOMI[1]
MibSPI5SIMO[2]	H17	25	26	H16	MibSPI5SOMI[2]
MibSPI5SIMO[3]	G17	27	28	G16	MibSPI5SOMI[3]
GND		29	30		GND
AD1IN[1]	V17	31	32	W14	AD1IN[0]
AD1IN[3]	T17	33	34	V18	AD1IN[2]
AD1IN[5]	R17	35	36	U18	AD1IN[4]
AD1IN[7]	V14	37	38	T19	AD1IN[6]
GND		39	40		GND
AD2IN[1]	U13	41	42	V13	AD2IN[0]
AD2IN[3]	U16	43	44	U14	AD2IN[2]
AD2IN[5]	T15	45	46	U15	AD2IN[4]
AD2IN[7]	R16	47	48	R19	AD2IN[6]
AGND		49	50		GND



**Table 2-7. Expansion Connector P1 (J9, Left, BottomView) (continued)**

Signal Name	Pin Number	Number	Pin Number	Signal Name	
AD1IN[9]	W17	51	52	P18	AD1IN[8]
AD1IN[11]	U19	53	54	U17	AD1IN[10]
AD1IN[13]	T18	55	56	T16	AD1IN[12]
AD1IN[15]	P19	57	58	R18	AD1IN[14]
GND		59	60		POR_RSTn
ADREFHI	V15	61	62	V16	ADREFLO
AD1EVT	N19	63	64	V10	AD2EVT
EXP_12V		65	66		GND

**Table 2-8. Expansion Connector P2 (J10, Right, BottomView)**

Signal Name	Pin Number	Number	Pin Number	Signal Name	
EXP_12V		1	2	GND	
ECLK	A12	3	4	B14	ERRORn
RST		5	6	M17	EMIF_CS[4]
NC	C17	7	8	C16	NC
NC	C15	9	10	D15	NC
NC	C14	11	12	D14	NC
NC	C13	13	14	C12	NC
NC	C11	15	16	C10	EMIF_ADDR[12]
EMIF_ADDR[11]	C9	17	18	C8	EMIF_ADDR[10]
EMIF_ADDR[9]	C7	19	20	C6	EMIF_ADDR[8]
EMIF_ADDR[7]	C5	21	22	C4	EMIF_ADDR[6]
EMIF_ADDR[5]	D9	23	24	D8	EMIF_ADDR[4]
EMIF_ADDR[3]	D7	25	26	D6	EMIF_ADDR[2]
EMIF_ADDR[1]	D5	27	28	D4	EMIF_ADDR[0]
GND		29	30		GND
EMIF_Wen	D17	31	32	K17	EMIF_CS[3]
EMIF_Oen	D12	33	34	L17	EMIF_CS[2]
EMIF_BA[1]	D16	35	36	D11	EMIF_DQMn[1]
EMIF_BA[0]	D13	37	38	D10	EMIF_DQMn[0]
GND		39	40		GND
EMIFDATA[1]	L16	41	42	K16	EMIFDATA[0]
EMIFDATA[3]	N16	43	44	M16	EMIFDATA[2]
EMIFDATA[5]	F4	45	46	E4	EMIFDATA[4]
EMIFDATA[7]	K4	47	48	G4	EMIFDATA[6]
EMIFDATA[9]	M4	49	50	L4	EMIFDATA[8]
EMIFDATA[11]	P4	51	52	N4	EMIFDATA[10]
EMIFDATA[13]	T6	53	54	T5	EMIFDATA[12]
EMIFDATA[15]	T8	55	56	T7	EMIFDATA[14]
GND		57	58		GND
SPI2_SOMI	D2	59	60	P3	EMIF_nWAIT
SPI2_SIMO	D1	61	62	D3	SPI2_CS1
SPI2_CS0	N3	63	64	E2	SPI2_CLK
EXP_12V		65	66		GND

**Table 2-9. Expansion Connector P3 (J11, Bottom One, TopView)**

Signal Name	Pin Number	Number	Pin Number	Signal Name	
EXP_12V		1	2	GND	
EXP_12V		3	4	GND	
LINRX	A7	5	6	B7	LINTX
CAN1RX	B10	7	8	A10	CAN1TX
CAN2RX	H1	9	10	H2	CAN2TX
CAN3RX	M19	11	12	M18	CAN3TX
FRAYRX1	A15	13	14	A8	FRAYRX2
FRAYTX1	B15	15	16	B8	FRAYTX2
FRAYTXEN1	B16	17	18	B9	FRAYTXEN2
GIOA[1]	C2	19	20	A5	GIOA[0]
GIOA[3]	E1	21	22	C1	GIOA[2]
GIOA[5]	B5	23	24	A6	GIOA[4]
GIOA[7]	M1	25	26	H3	GIOA[6]
GIOB[1]	K2	27	28	M2	GIOB[0]
GIOB[3]	W10	29	30	F2	GIOB[2]
GIOB[5]	G2	31	32	G1	GIOB[4]
GIOB[7]	F1	33	34	J2	GIOB[6]
GND		35	36		GND
NHET1[1]	V2	37	38	K18	NHET1[0]
NHET1[3]	U1	39	40	W5	NHET1[2]
NHET1[5]	V6	41	42	B12	NHET1[4]
NHET1[7]	T1	43	44	W3	NHET1[6]
NHET1[9]	V7	45	46	E18	NHET1[8]
NHET1[11]	E3	47	48	D19	NHET1[10]
NHET1[13]	N2	49	50	B4	NHET1[12]
NHET1[15]	N1	51	52	A11	NHET1[14]
NHET1[17]	A13	53	54	A4	NHET1[16]
NHET1[19]	B13	55	56	J1	NHET1[18]
NHET1[21]	H4	57	58	P2	NHET1[20]
NHET1[23]	J4	59	60	B3	NHET1[22]
NHET1[25]	M3	61	62	P1	NHET1[24]
NHET1[27]	A9	63	64	A14	NHET1[26]
NHET1[29]	A3	65	66	K19	NHET1[28]
NHET1[31]	J17	67	68	B11	NHET1[30]
GND		69	70		GND
MibSPI3CS[3]	C3	71	72	B2	MibSPI3CS[2]
MibSPI3SIMO	W8	73	74	V8	MibSPI3SOMI
MibSPI3CS[1]	V5	75	76	V10	MibSPI3CS[0]
MibSPI3ENA	W9	77	78	V9	MibSPI3CLK
EXP_12V		79	80		GND

## 2.3 LEDs

The TMS570LC43 HDK board has 19 LEDs. Eight of these LEDs (shown in [Table 2-10](#)) are under user control. Those LEDs are controlled and programmed by NHET signals.

LEDs DS2, DS3, DS4, and DS5 indicate the presence of the power (+1.2 V, +5 V, 3.3 V, and 12 V) s on the board. The LED functions are summarized in [Table 2-10](#) and [Table 2-11](#).

**Table 2-10. Demo LEDs**

LED Number	Location	Signals	Color
D3	Left Top	NHET1[17]	White
D4	Top	NHET1[31]	White
D5	Right Top	NHET1[0]	White
D6	Right Bottom	NHET1[25]	White
D7	Bottom	NHET1[18]	White
D8	Left bottom	NHET1[29]	White
LED1	Left	NHET1[27]	White
LED2	Right	NHET1[05]	White

**Table 2-11. Other LEDs as Indicator**

Number	LED	Color
D1	nERROR	Red
D10	XDS100V2 SCI RX	Blue
D11	XDS100V2 SCI TX	Blue
D12	XDS100V2 PWRENn	Blue
D2	JTAG TDI	Blue
D9	Ethernet Speed	Blue
DS1	ARM JTAG Plugin	Blue
DS2	VCC_1V2	Blue
DS3	VCC_5V	Blue
DS4	VCC_3V3	Blue
DS5	VCC_12V	Blue

## 2.4 S2 DIP Switch

There is one 4-position DIP switches located on the left-bottom corner at reference designator S2. By default, all of the switches are set to the “OFF” position and should remain in that position when completing the steps in this user's guide.

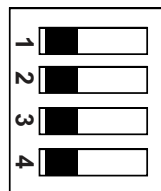

**Figure 2-8. DIP Switch Settings**

The S2 DIP switch is reserved for user application general purpose. [Table 2-12](#) describes the function of each channel on S2.

**Table 2-12. S2 DIP Switch Functions**

Switch	OFF Position	ON Position
S2:1 <sup>(1)</sup>	USB Host0 Disabled	USB Host0 Enabled
S2:2 <sup>(2)</sup>	USB Host1 Disabled	USB Host1 Enabled
S2:3 <sup>(2)</sup>	USB Device Disabled	USB Device Enabled
S2:4 <sup>(3)</sup>	Ethernet Disabled	Ethernet Enabled

<sup>(1)</sup> S2:1 indicates slide 1 on the S2 DIP switch, S2:2 indicates slide 2 on the S2 DIP switch, and so on.

<sup>(2)</sup> S2:2 and S2:3 cannot be enabled at the same time since those two ports have pinmux.

<sup>(3)</sup> To use Ethernet, S2:4 should be enabled and all other have to be disabled.

## 2.5 Jumpers

The HDK board has two jumpers that are used to enable and disable the on-board SDRAM and select 5 V or 3.3 V ADC.

**Table 2-13. Jumpers**

Jumper Number	OFF	ON
J8	5 V ADC	3.3 V ADC
J13	SDRAM on	SDRAM Off

## 2.6 S4, Power On Reset Switch

TMS570LC43 MCU has two resets: warm reset (nRST) and power-on reset (nPORRST). Switch S4 is a momentary switch that asserts power on reset to the TMS570LC4357 device. The nPORRST condition is intended to reset all logic on the device including the test and emulation circuitry.

## 2.7 S3, System Reset Switch

Switch S3 is used to assert a warm reset the TMS570LC4357 device. Warm reset does not reset any test or emulation logic. The reset signal from window watchdog will also assert a warm reset to the MCU. The warm reset can be invoked by pushing nRST button, or by RESET signals from XDS100 CPLD, ARM JTAG SREST.

## Operation Notices

---

---

### A.1 Operation Notices

The user assumes all responsibility and liability for proper and safe handling of the boards. It is the user's responsibility to take any and all appropriate precautions with regard to electrostatic discharge.

- For additional information regarding the embedded emulation, see the XDS100 USB wiki on the TI web site at the following URL: <http://tiexpressdsp.com/index.php?title=XDS100>
- Code Composer Studio support is available via a forum at: <http://community.ti.com/forums/138.aspx>
- Hercules MCU support is available via a forum at: <http://www.ti.com/hercules-support>



---

## Revision History

NOTE: Page numbers for previous revisions may differ from page numbers in the current version.

<b>Changes from Original (May 2014) to A Revision</b>	<b>Page</b>
• Updated TMS570LC43 HDK Contents power supply information. ....	<b>6</b>

---

## IMPORTANT NOTICE AND DISCLAIMER

TI PROVIDES TECHNICAL AND RELIABILITY DATA (INCLUDING DATASHEETS), DESIGN RESOURCES (INCLUDING REFERENCE DESIGNS), APPLICATION OR OTHER DESIGN ADVICE, WEB TOOLS, SAFETY INFORMATION, AND OTHER RESOURCES "AS IS" AND WITH ALL FAULTS, AND DISCLAIMS ALL WARRANTIES, EXPRESS AND IMPLIED, INCLUDING WITHOUT LIMITATION ANY IMPLIED WARRANTIES OF MERCHANTABILITY, FITNESS FOR A PARTICULAR PURPOSE OR NON-INFRINGEMENT OF THIRD PARTY INTELLECTUAL PROPERTY RIGHTS.

These resources are intended for skilled developers designing with TI products. You are solely responsible for (1) selecting the appropriate TI products for your application, (2) designing, validating and testing your application, and (3) ensuring your application meets applicable standards, and any other safety, security, or other requirements. These resources are subject to change without notice. TI grants you permission to use these resources only for development of an application that uses the TI products described in the resource. Other reproduction and display of these resources is prohibited. No license is granted to any other TI intellectual property right or to any third party intellectual property right. TI disclaims responsibility for, and you will fully indemnify TI and its representatives against, any claims, damages, costs, losses, and liabilities arising out of your use of these resources.

TI's products are provided subject to TI's Terms of Sale ([www.ti.com/legal/termsofsale.html](http://www.ti.com/legal/termsofsale.html)) or other applicable terms available either on [ti.com](http://ti.com) or provided in conjunction with such TI products. TI's provision of these resources does not expand or otherwise alter TI's applicable warranties or warranty disclaimers for TI products.

Mailing Address: Texas Instruments, Post Office Box 655303, Dallas, Texas 75265  
Copyright © 2018, Texas Instruments Incorporated