



MAX6683 Evaluation System/Evaluation Kit

General Description

The MAX6683 evaluation system (EV system) consists of a MAX6683 evaluation kit (EV kit) and a companion Maxim CMODUSB board.

The MAX6683 EV kit is an assembled and tested printed circuit board (PCB) that demonstrates the MAX6683 temperature sensor and system monitor. The MAX6683 monitors temperature, supply voltage, and the voltage of three external supplies. Temperature is converted to 11-bit serial data and voltage to 8-bit data.

The CMODUSB allows a PC to use its USB port to emulate an Intel SMBus. Windows® 98SE/2000/XP-compatible software provides a user-friendly interface to exercise the features of the MAX6683. The program is menu driven and offers a graphic interface with control buttons and status display.

Order the EV system (MAX6683EVCMODU) for a complete PC-based evaluation of the MAX6683. Order just the EV kit (MAX6683EVKIT) if you already have an SMBus interface.

To evaluate the MAX6652, order a free sample of the MAX6652AUB.

Features

- ◆ Measure and Display the MAX6683 Temperature
- ◆ Monitor Four Voltage Channels
 - Three External (1.8V, 2.5V, and 5V Nominal)
 - VCC Pin (3.3V Nominal)
- ◆ Programmable Alarms and Configuration
- ◆ SMBus/I²C Compatible
- ◆ Easy-to-Use Menu-Driven Software
- ◆ Fully Assembled and Tested
- ◆ Include Windows 98SE/2000/XP-Compatible Software and Demo PCB
- ◆ EV System Includes USB Connectivity

Ordering Information

PART	TEMP RANGE	INTERFACE TYPE
MAX6683EVKIT	0°C to +70°C	Not included
MAX6683EVCMODU	0°C to +70°C	CMODUSB

Note: The MAX6683 EV kit software is provided with the MAX6683EVKIT. However, the CMODUSB board is required to interface the EV kit to the computer when using the software.

Component Lists

MAX6683 EV System

PART	QTY	DESCRIPTION
MAX6683EVKIT	1	MAX6683 evaluation kit
CMODUSB+	1	Serial interface board

+Denotes lead-free and RoHS compliance.

MAX6683 EV Kit

DESIGNATION	QTY	DESCRIPTION
C1, C2	2	0.1µF, 16V X7R ceramic capacitors Taiyo Yuden EMK107BJ104KA Murata GRM188R71C104KA01 TDK C1608X7R1C104K
C3	1	2.2µF, 16V X7R ceramic capacitor Taiyo Yuden EMK316BJ225ML Murata GRM42-6X7R225K016 TDK C3216X7R1C225M
J1	1	2 × 10 right-angle female
JU1	1	2 × 4 straight header
JU2	0	Not installed
R1, R2, R3	3	10kΩ ±5% resistors
R4	1	470kΩ ±5% resistor
SW1	1	Slide switch
U1	1	MAX6683AUB
U2	1	MAX1615EUK
—	1	Shunt for JU1
—	1	PCB: MAX6683 Evaluation Kit

SMBus is a trademark of Intel Corp.

Windows is a registered trademark of Microsoft Corp.



MAX6683 Evaluation System/Evaluation Kit

Component Suppliers

SUPPLIER	PHONE	FAX	WEBSITE
Murata Mfg. Co., Ltd.	770-436-1300	770-436-3030	www.murata.com
Taiyo Yuden	800-348-2496	847-925-0899	www.t-yuden.com
TDK Corp.	847-803-6100	847-390-4405	www.component.tdk.com

Note: Indicate that you are using the MAX6683 when contacting these component suppliers.

Quick Start

Recommended Equipment

- MAX6683 EV system
 - MAX6683 EV kit
 - Maxim CMODUSB interface board
 - USB cable (included with the CMODUSB)
- A user-supplied Windows 98SE/2000/XP PC with spare USB port
- 3.3V power supply for VCC
- 1.8V power supply*
- 2.5V power supply*
- 5V power supply*

Note: In the following sections, software-related items are identified by bolding. Text in **bold** refers to items directly from the EV kit software. Text in **bold and underlined** refers to items from the Windows 98SE/2000/XP operating system.

Procedure

The MAX6683 EV kit is fully assembled and tested. Follow the steps below to verify board operation.

Caution: Do not turn on the power supplies until all connections are completed.

- 1) Visit the Maxim website (www.maxim-ic.com/evkit-software) to download the latest version of the EV kit software, 6683Rxx.ZIP.
- 2) Install the MAX6683 EV kit software on your computer by running the INSTALL.EXE program. The program files are copied and icons are created in the Windows **Start** menu.
- 3) Carefully connect the boards by aligning the 20-pin connector of the MAX6683 EV kit with the 20-pin header of the CMODUSB interface board. Gently press them together.
- 4) Ensure that a shunt is on pins 1-2 of jumper JU4. Do not turn on the power until all connections are made.

- 5) Connect the 3.3V power supply to the VCC and GND pads.
- 6) Connect the 1.8V nominal power supply to the 1.8 VIN and GND pads.
- 7) Connect the 2.5V nominal power supply to the 2.5 VIN and GND pads.
- 8) Connect the 5V nominal power supply to the 5 VIN and GND pads.
- 9) Connect the USB cable from the PC to the CMODUSB board. A **Building Driver Database** window pops up in addition to a **New Hardware Found** message. If you do not see a window that is similar to the one described above after 30 seconds, remove the USB cable from the CMODUSB and reconnect it. Administrator privileges are required to install the USB device driver on Windows 98SE/2000/XP. Refer to the TROUBLESHOOTING_USB.PDF document included with the software if you have any problems during this step.
- 10) Follow the directions of the **Add New Hardware Wizard** to install the USB device driver. Choose the **Search for the best driver for your device** option. Specify the location of the device driver to be **C:\Program Files\MAX6683** (or the directory chosen during installation) using the **Browse** button.
- 11) Turn on the power supplies.
- 12) Turn on the EV kit by moving SW1 to the ON position.
- 13) Start the MAX6683 EV kit software by clicking on its icon in the **Start** menu.
- 14) Wait until the program automatically detects the address of the MAX6683 and displays the user-interface panel (Figure 1).
- 15) Select the **Configuration** tab on the panel (Figure 2). Uncheck the **Interrupt Clear** checkbox.
- 16) Check the **START** checkbox.
- 17) Verify that the internal temperature displayed on the user-interface panel is not 0.000°C.

*These supplies are optional; however, if different nominal supplies are used, appropriate threshold values should be programmed.

MAX6683 Evaluation System/Evaluation Kit

Evaluate: MAX6652/MAX6683

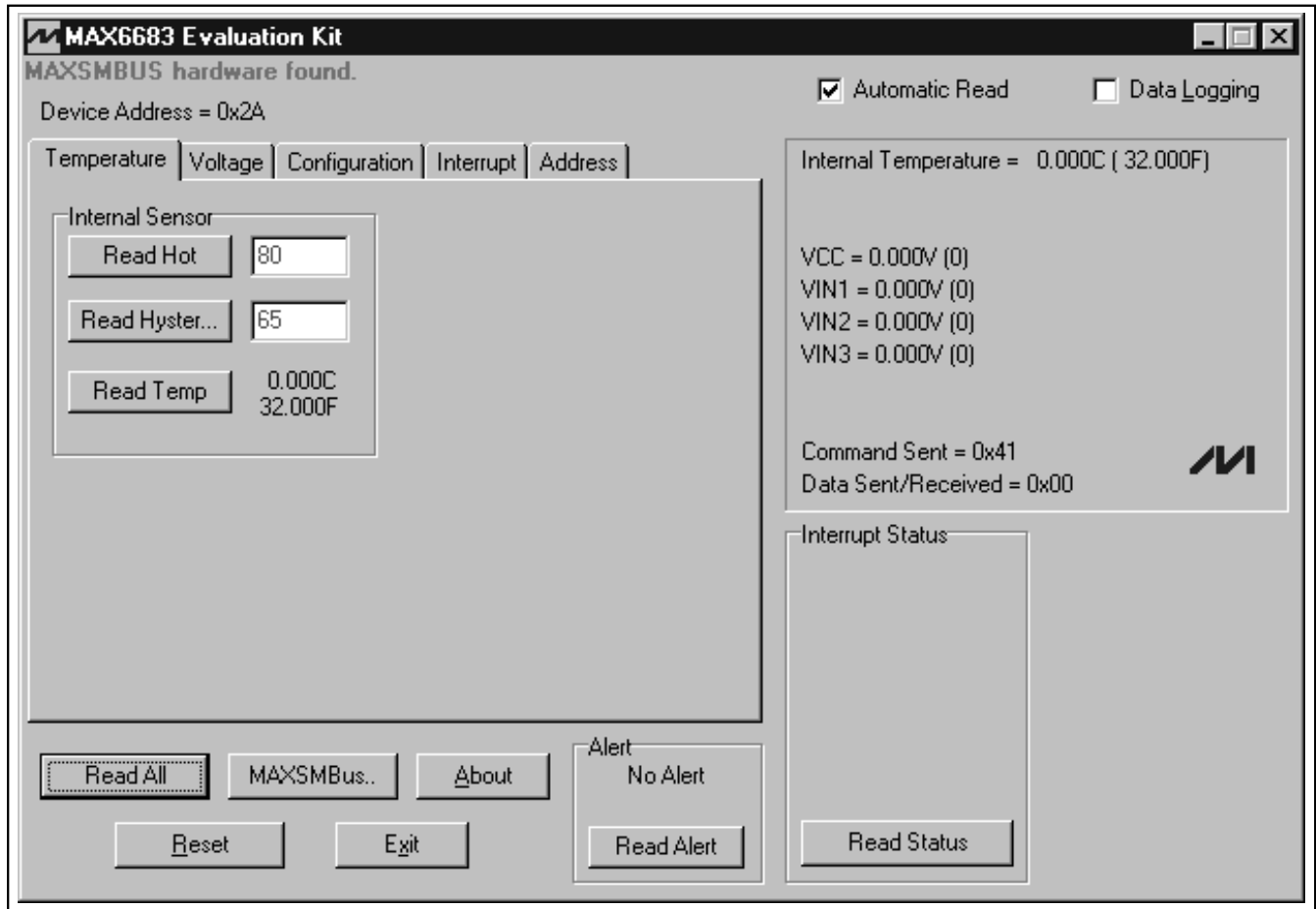

Figure 1. MAX6683 EV Kit User-Interface Panel

MAX6683 Evaluation System/Evaluation Kit

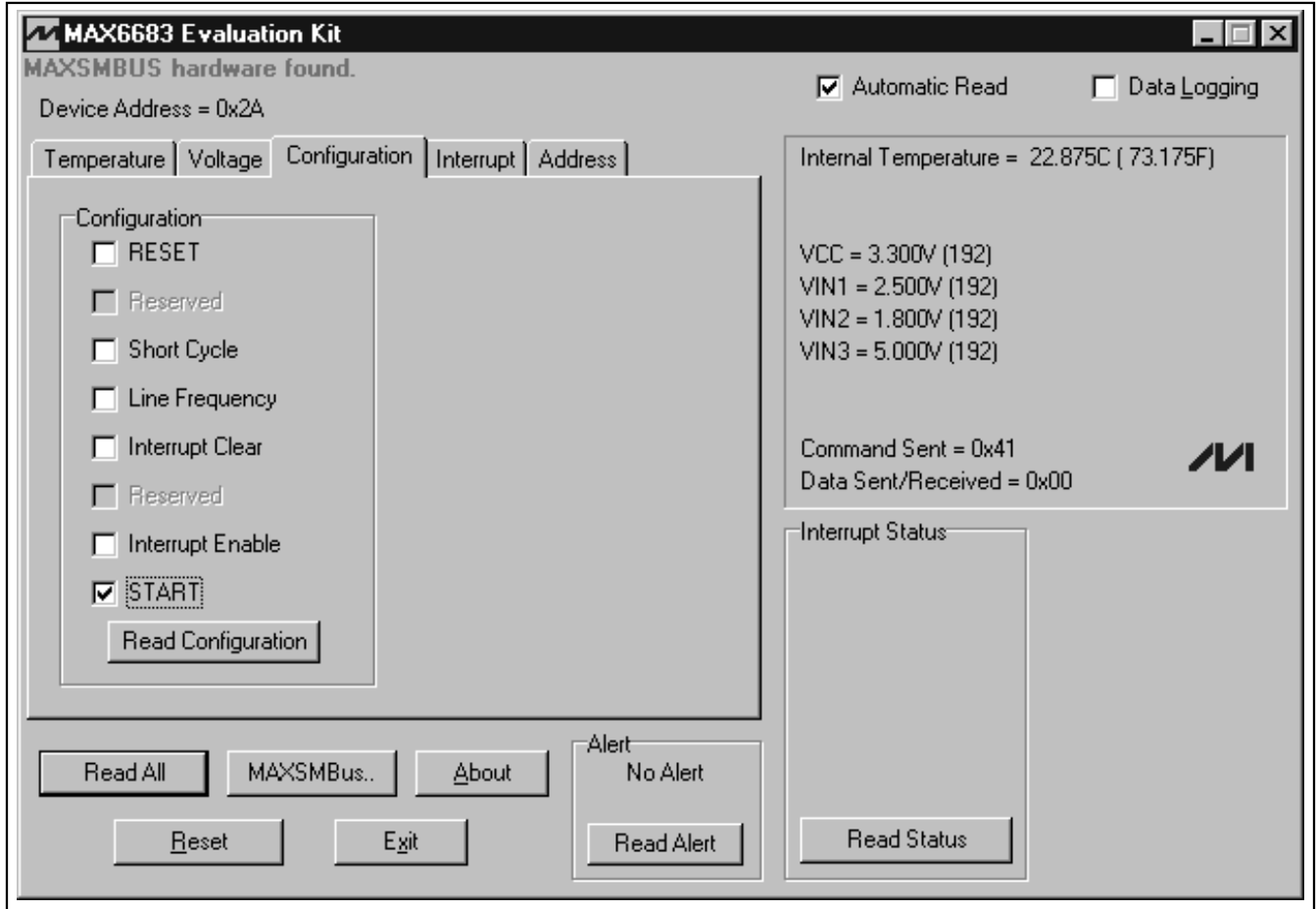

Figure 2. MAX6683 EV Kit Configuration Display

MAX6683 Evaluation System/Evaluation Kit

Detailed Description

User-Interface Panel

The user interface is easy to operate using the mouse, or by using the tab key to navigate with the arrow keys. The checkboxes, edit fields, and radio buttons correspond to bits in the internal registers. By clicking on them, the correct SMBus write operation is generated to update the registers.

The program monitors for an alert interrupt and continually polls the device for new temperature, voltage, and status data. To disable the continuous polling of data, uncheck the **Automatic Read** checkbox. To change the temperature or voltage threshold comparison registers, select the appropriate data field and type in the new value. Pressing Enter, after typing in the new values, updates the internal registers.

The message **ALERT** appears whenever an interrupt condition occurs. To clear the interrupt, first eliminate the condition that caused it and then click on **Read Status**.

Simple SMBus Commands

There are two methods for communicating with the MAX6683: through the normal user-interface panel or through the SMBus commands available from pressing the **MAXSMBus..** button. A display appears that allows the SMBus protocols, such as Read Byte and Write Byte, to be executed. To stop normal user-interface execution so that it does not override the manually set values, turn off the update timer that slaves the program to the conversion rate by unchecking the **Automatic Read** checkbox.

The SMBus dialog boxes accept numeric data in binary, decimal, or hexadecimal. Hexadecimal numbers should be prefixed by \$ or 0x. Binary numbers must be exactly eight digits.

Note: In places where the slave address asks for an 8-bit value, it must be the 7-bit slave address of the MAX6683 as determined by the address pin (ADD) with the last bit set to 1 for a read operation and 0 for a write.

Data Logging

Check the **Data Logging** checkbox to activate data logging. Data logging saves temperature, voltage, and status data to a text file that includes a time/date stamp next to each data point. If **Automatic Read** is enabled, data is sampled at 2Hz; however, the data is logged to the file only if the temperature, voltage, or status change. This slows the growth of the data-logging file. When **Automatic Read** is disabled, the data is logged each time the **Read All** button is clicked. To stop data logging, uncheck the **Data Logging** checkbox.

Jumper and Switch Settings

Jumper 1 (JU1) sets the MAX6683 slave address. The default address is 0010 101 (ADD = VCC); see Table 1 for a complete list of addresses. The slide switch, SW1, provides a means to force a reset. This switch disables power to the device.

Table 1. JU1 Shunt Settings for SMBus Address

SHUNT LOCATION	ADD CONNECTION	MAX6683 ADDRESS
0x28	To GND	0010 100Y
0x2A	To VCC	0010 101Y
0x2C	To SDA	0010 110Y
0x2E	To SCL	0010 111Y

Note: The first 7 bits shown are the address. Y (bit 0) is the SMBus read/write bit. This bit is a 1 for a read operation and zero for a write.

Evaluating the MAX6652

The MAX6683 EV kit can also evaluate the MAX6652. Remove the MAX6683 from the board and install the MAX6652.

The MAX6652 and MAX6683 monitor different voltages. See Table 2.

When evaluating the MAX6652 with the MAX6683 software, the voltages displayed for the supply voltage (VCC), the 1.8V nominal voltage, and the 5V nominal voltage are incorrect. However, the ADC output code, shown in parentheses next to the voltage, is correct. Use the equations shown below to calculate the actual voltages:

$$V_{CC} = \frac{5V \times \text{ADC output code}}{192}$$
$$\text{Voltage on pin 1} = \frac{12V \times \text{ADC output code}}{192}$$
$$\text{Voltage on pin 3} = \frac{3.3V \times \text{ADC output code}}{192}$$

Table 2. Voltage Monitor Differences Between MAX6652 and MAX6683

PIN	MAX6652 (V)	MAX6683 (V)
10 (VCC)	5	3.3
1	12	1.8
3	3.3	5

MAX6683 Evaluation System/Evaluation Kit

Evaluate: MAX6652/MAX6683

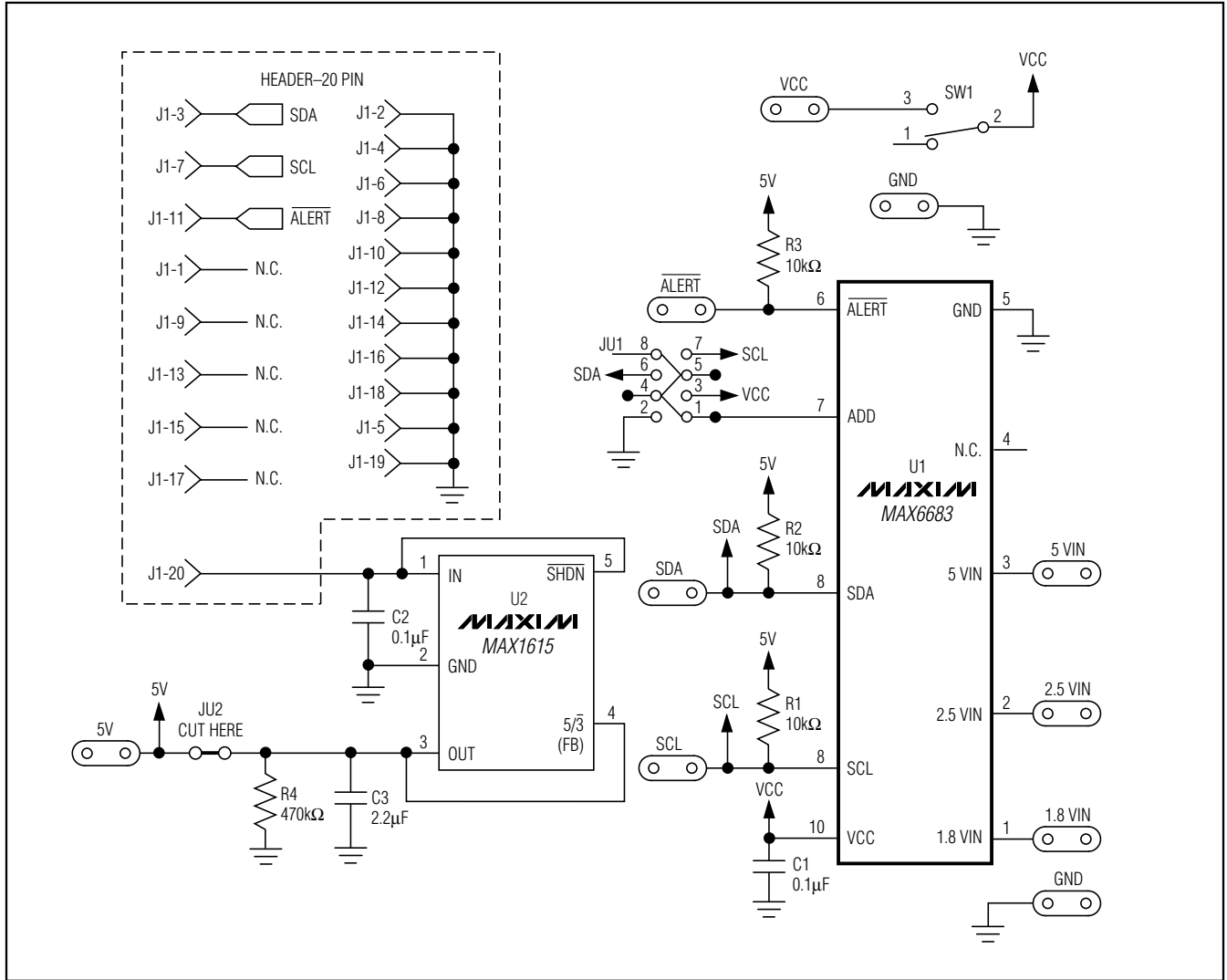

Figure 3. MAX6683 EV Kit Schematic

MAX6683 Evaluation System/Evaluation Kit

Evaluate: MAX6652/MAX6683

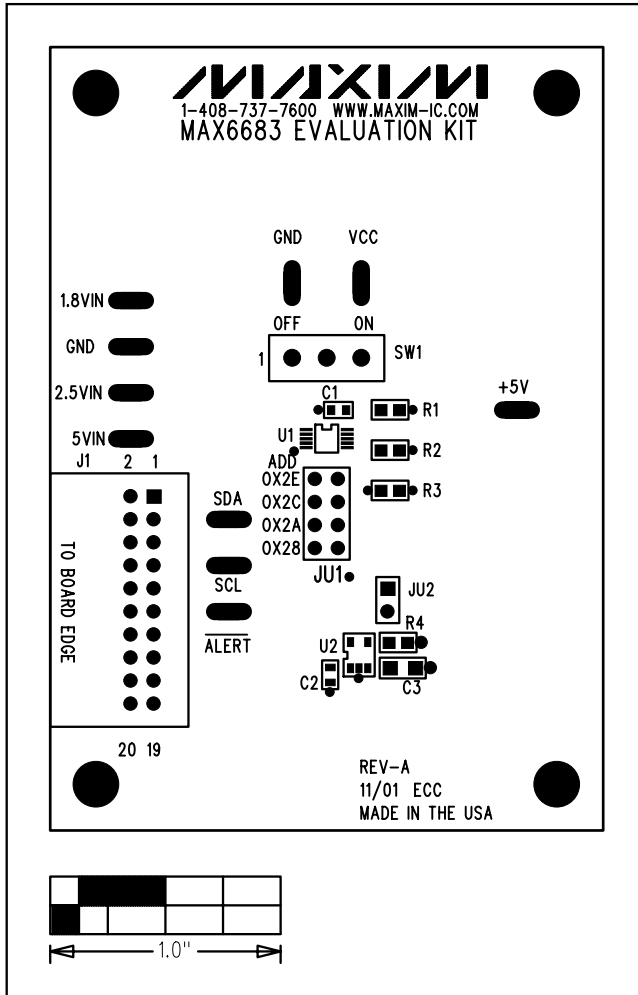

Figure 4. MAX6683 EV Kit Component Placement Guide—Component Side

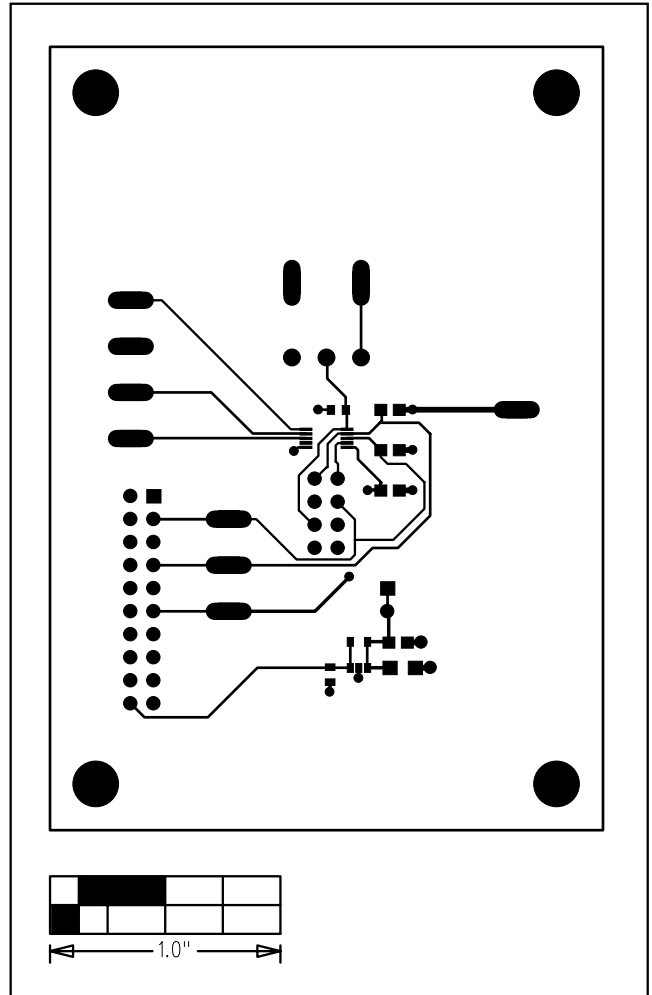

Figure 5. MAX6683 EV Kit PCB Layout—Component Side

MAX6683 Evaluation System/Evaluation Kit

Evaluate: MAX6652/MAX6683

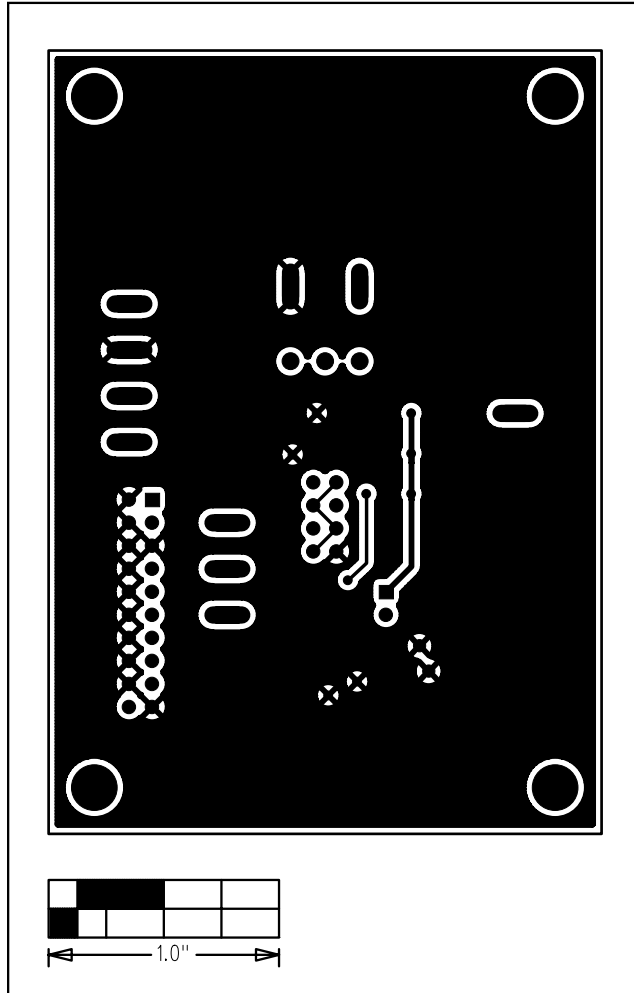

Figure 6. MAX6683 EV Kit PCB Layout—Solder Side

Revision History

Pages changed at Rev 1: 1–5, 7, 8

Maxim cannot assume responsibility for use of any circuitry other than circuitry entirely embodied in a Maxim product. No circuit patent licenses are implied. Maxim reserves the right to change the circuitry and specifications without notice at any time.

8 **Maxim Integrated Products, 120 San Gabriel Drive, Sunnyvale, CA 94086 408-737-7600**

© 2007 Maxim Integrated Products

MAXIM is a registered trademark of Maxim Integrated Products, Inc.