

REVISIONS					
P	LTR	DESCRIPTION	DATE	DMN	APVD
E		REV PER ECO 20-001902	4-30-20	CT	DM

1. THIS RECEPTACLE WILL MATE WITH ANY SIZE 5,78 POSN. PLUG IN AMPLIMITE SERIES.
2. CONNECTOR SUPPLIED WITHOUT CONTACTS; SHOWN FOR ILLUSTRATION ONLY.
3. BE-CU RETENTION CLIPS ARE INCLUDED IN INSERTS AND INSTALLED WITH TINES POINTING TOWARDS MATING FACE.
4. OVERALL DIMENSIONS DO NOT INCLUDE RAISED CAVITY IDENTIFICATION
5. MARKING FAR SIDE REFERS TO WIDE SIDE OF KEYSTONE. NEAR SIDE REFERS TO NARROW SIDE OF KEYSTONE.
6. 100% INSPECTION REQUIRED PER BOEING 1B01:
 - A. VISUAL
 - B. DWV
 - C. IR
7. CUSTOMER REQUIRES SINGLE LOT DATE CODE.

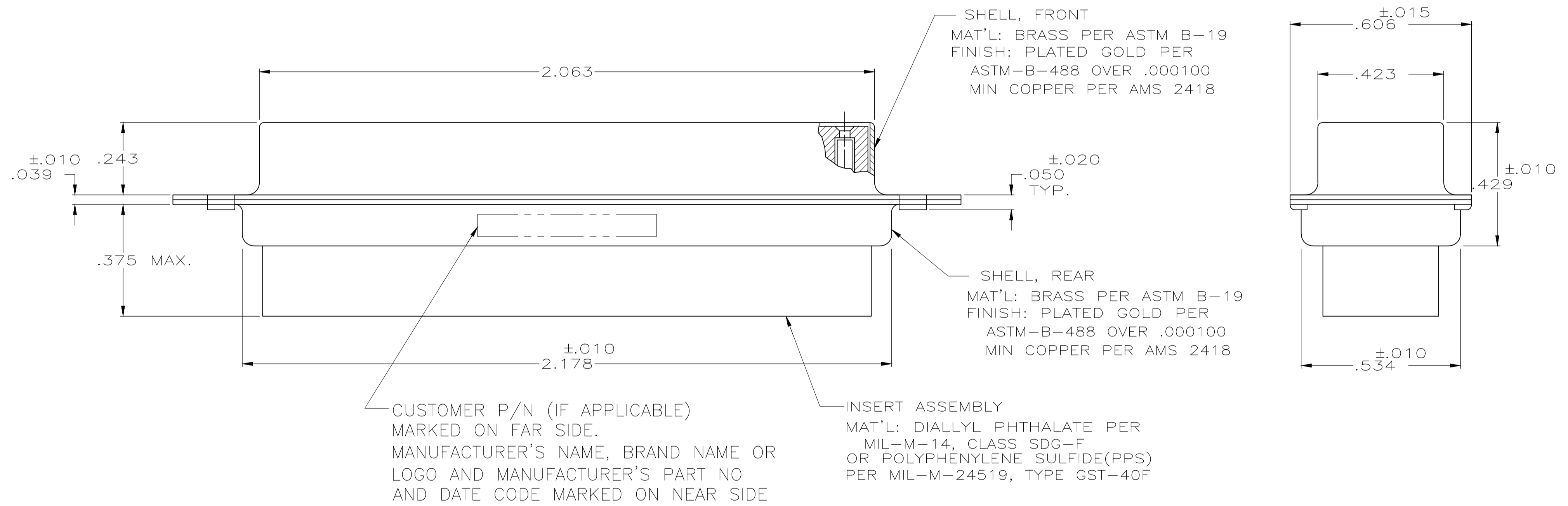
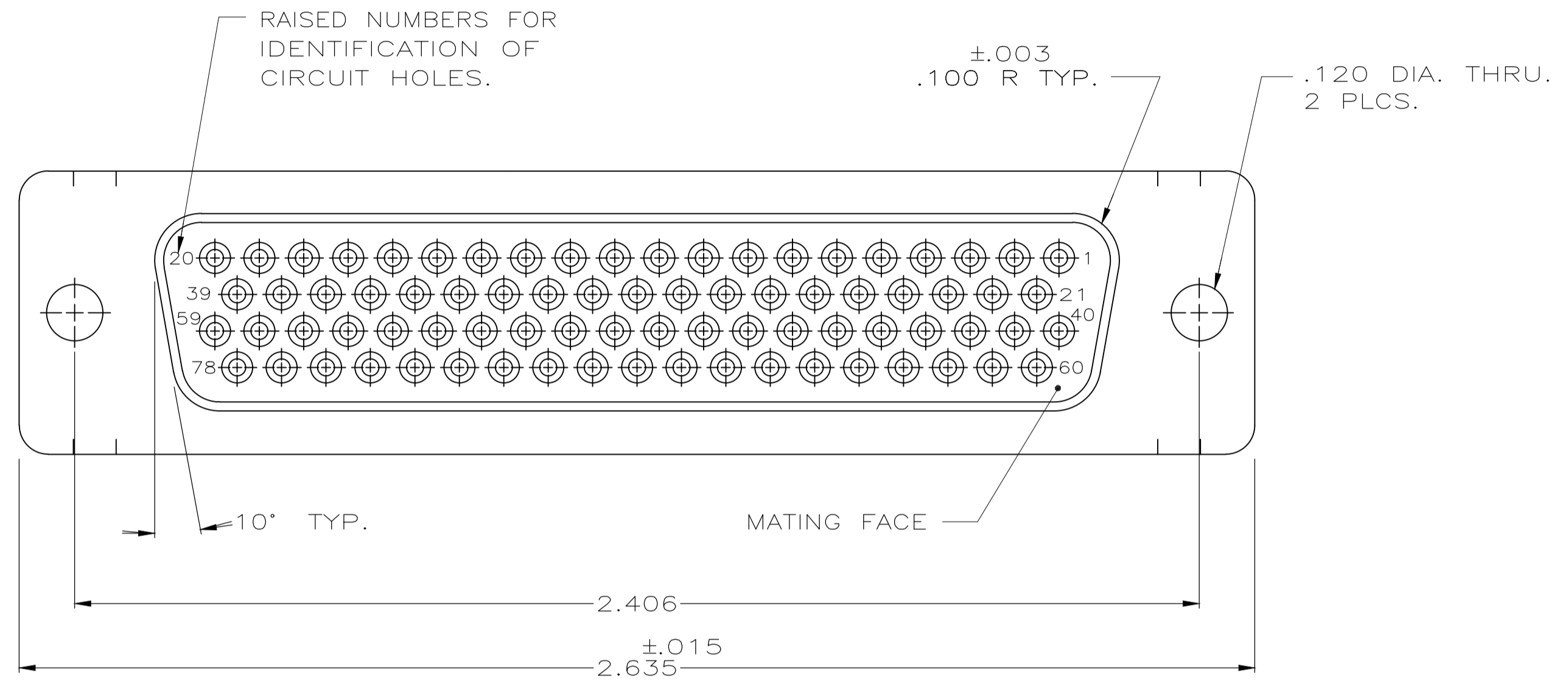

REMARKS	1B01-005RHW	1-211647-1
	1B01-005	211647-1
REMARKS	CUSTOMER PART NUMBER	PART NO.

THIS DRAWING IS A CONTROLLED DOCUMENT.

DIMENSIONS: INCHES	TOLERANCES UNLESS OTHERWISE SPECIFIED:	DIN D. ERDMAN 160CT2008	APVD B. YOHN 160CT2008
0 PLC ± -	1 PLC ± -	APVD J. BROSCARD 1602008	NAME RECEPTACLE ASS'Y, AMPLIMITE 78 POSN, SIZE 5, SERIES 90 NON-MAGNETIC
2 PLC ± -	3 PLC ± .005	SIZE A1	CAGE CODE 00779
4 PLC ± -	ANGLES ± # 0'30"	WEIGHT 0.000000	DRAWING NO 211647
MATERIAL SEE CALLOUT	FINISH SEE CALLOUT	CUSTOMER DRAWING	RESTRICTED TO -

SCALE NTS SHEET 1 OF 1 REV E