

REV.	DESCRIPTION	DATE	APPROVED
B	Engineering Release.	11/20/14	J. C.

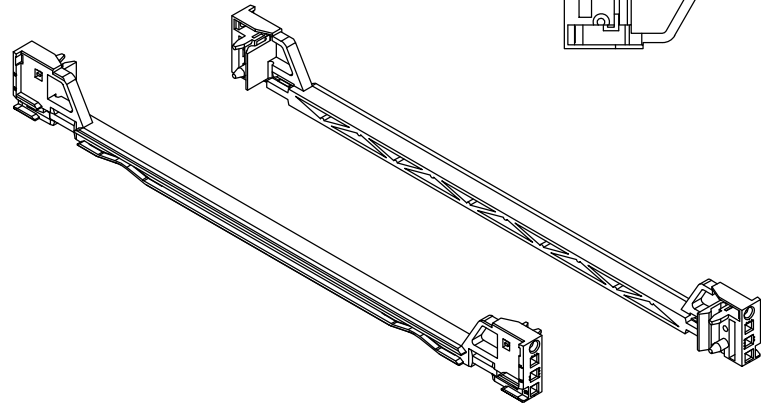
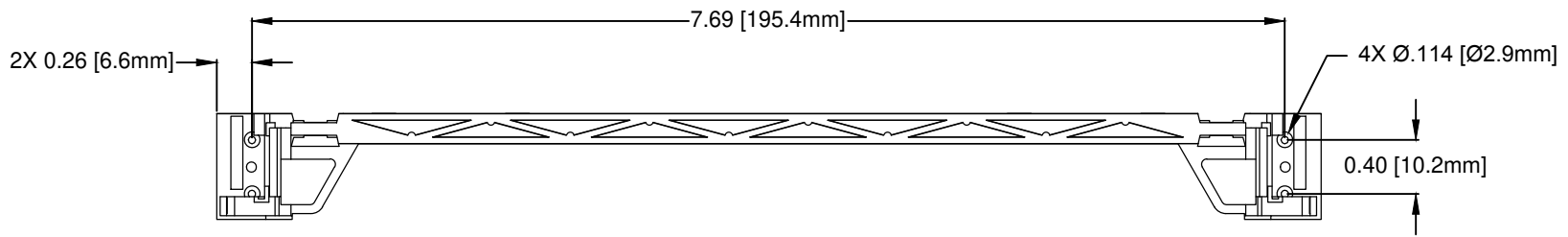
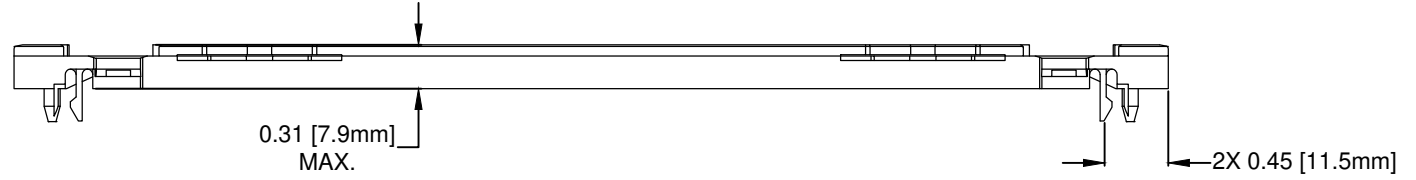
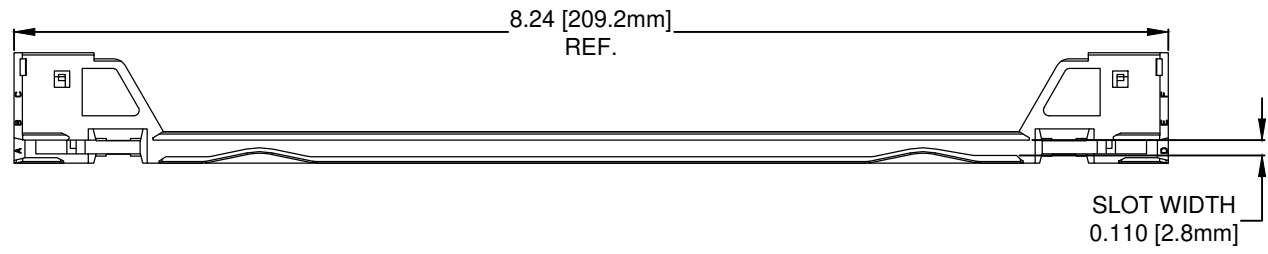
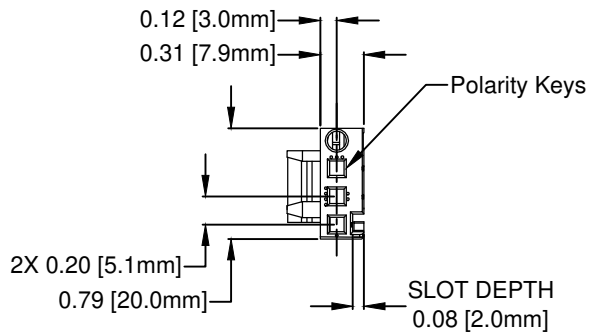

ORDERING INFORMATION

PART NUMBER	COLOR
CPCI-220	GREY
CPCI-220Y	YELLOW
CPCI-220R	RED
CPCI-220G	GREEN

- 2. MATERIAL: POLYCARBONATE, GLASS FILLED 20%
- 1. GENERAL SPECIFICATIONS: BIVAR MOLDED COMPONENT SPECIFICATION BV00-E101.

STANDARD TOLERANCE (UNLESS OTHERWISE SPECIFIED)		 4 THOMAS, IRVINE, CA 92618 TEL: (949) 951-8808 FAX: (949) 951-3974		
DECIMALS	ANGULAR			
.X ±.1	X° ± 1°	TITLE: 220mm COMPACT-PCI CARD GUIDE		
.XX ±.01				
.XXX ±.005			REVISION: B	
DESIGNED: Alex Wright	DATE: 08/21/14	PART NO: CPCI-220X		
CHECKED: Brian Oliver	DATE: 08/21/14	CAGE CODE : 32559 SHEET # 1 OF 1		
CAD GENERATED DOCUMENT, DO NOT MEASURE DRAWING.				