

NCX8193

Audio jack detection and configuration with false detection prevention

Rev. 2 — 21 November 2014

Product data sheet

1. General description

The NCX8193 is an advanced audio jack accessory detector and controller. It supports 3-pole and 4-pole connectors and detects the insertion of plugs into jacks using a fault detection technique. An internal microphone bias line switch allows a codec or application processor to control the audio jack configuration. The device supports a broad variety of after-market headphones.

2. Features and benefits

- Fail-safe headset and headphone detection
- Low-power standby mode
- Click free switching
- Low THD and noise microphone pass through channel
- Send/End button detection
- Low ON resistance: 0.9 Ω (typical) at a supply voltage of 2.8 V
- ESD protection:
 - ◆ HBM JEDEC JDS-001 Class 3B exceeds 8 kV
- Operating ambient temperature -40°C to $+85^{\circ}\text{C}$

3. Applications

- Headphones with integrated microphone and remote control buttons

4. Ordering information

Table 1. Ordering information

Type number	Package			
	Temperature range	Name	Description	Version
NCX8193GU	-40°C to $+85^{\circ}\text{C}$	XQFN10	plastic, extremely thin quad flat package; no leads; 10 terminals; body $1.8 \times 1.4 \times 0.5$ mm	SOT1160-2

5. Marking

Table 2. Marking codes

Type number	Marking code
NCX8193GU	q8



6. Functional diagram

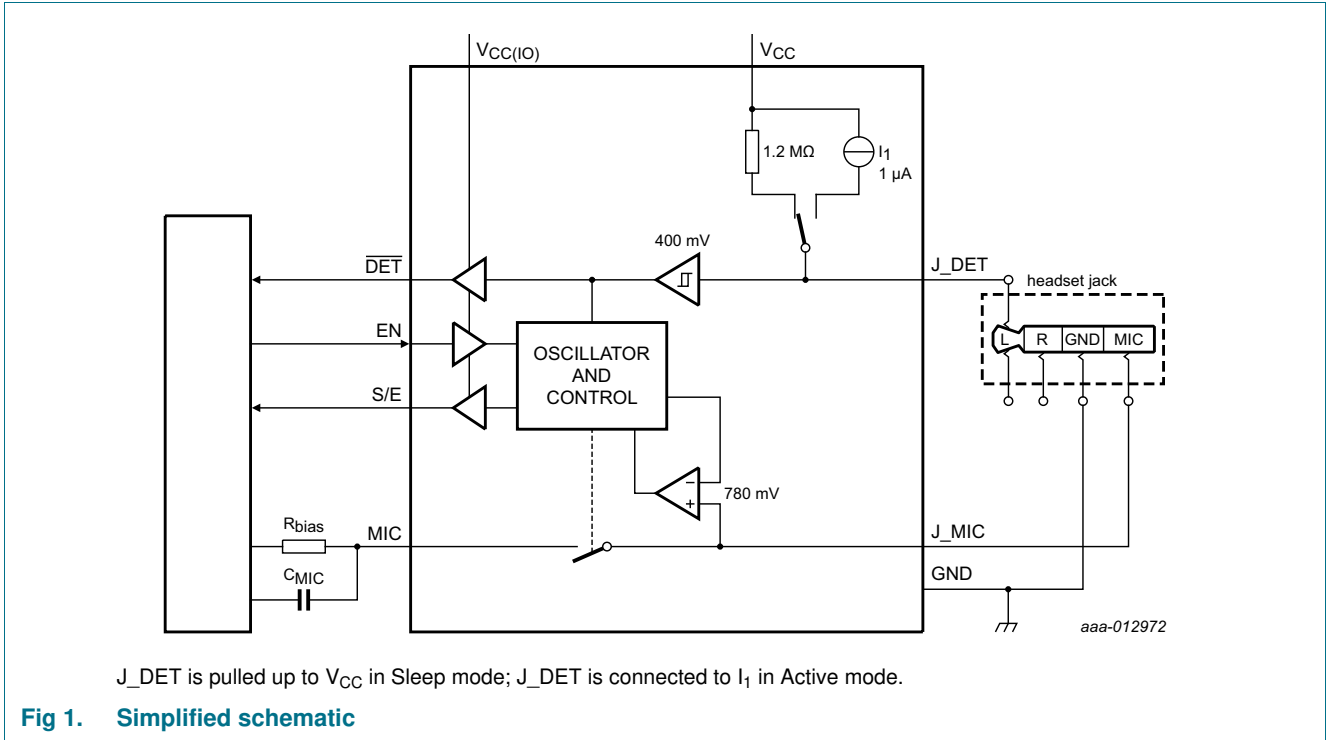

7. Pinning information

7.1 Pinning

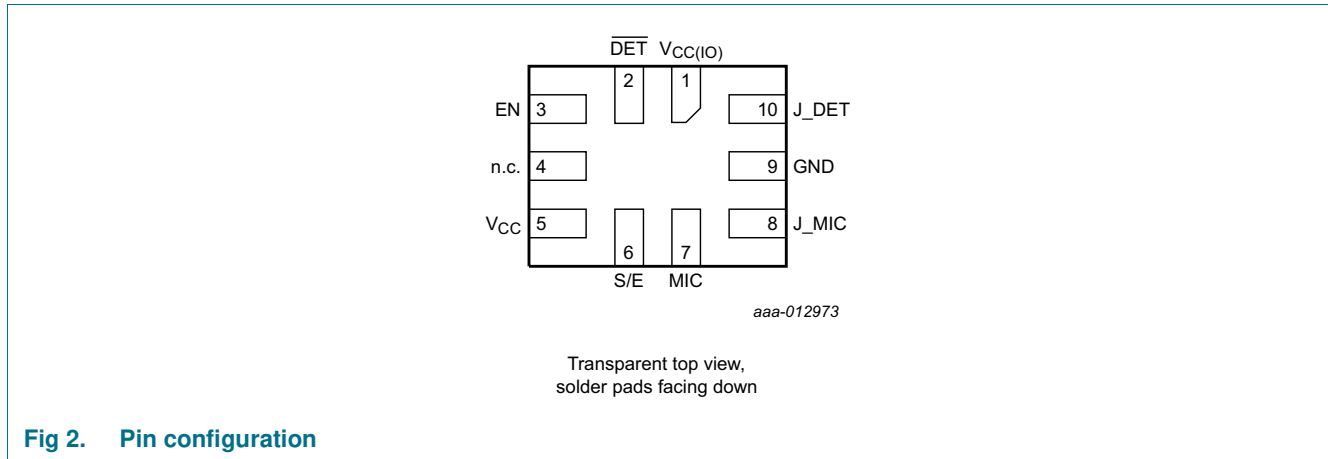

Fig 2. Pin configuration

7.2 Pin description

Table 3. Pin description

Symbol	Pin	Type	Description
$V_{CC(I/O)}$	1	Power	digital interface input/output supply voltage; headphone mode bias supply
\overline{DET}	2	O	plug detect; Plug inserted: \overline{DET} = LOW; unplugged: \overline{DET} = HIGH
EN	3	I	microphone bias path switch SWM control. closed: EN = HIGH; open: EN = LOW
n.c.	4	n.c.	not connected (preferably connected GND)
V_{CC}	5	Power	core supply (e.g. battery)
S/E	6	O	keypress-detect; key press: S/E = HIGH; NO key press: S/E = LOW
MIC	7	I/O	microphone bias connection audio codec side
J_MIC	8	I/O	microphone bias connection audio headset side
GND	9	ground	ground
J_DET	10	I/O	plug detection bias and logic level input

8. Functional description

The simplified schematic of the NCX8193 is shown in [Figure 1](#).

If no plug is inserted, J_DET is pulled-up to V_{CC} via a 1.2 MΩ resistor. Once J_DET is pulled below 400 mV, the pull-up resistor is switched out and J_DET is connected to a variable current source. The current source slowly increases its output current. If J_DET remains lower than 300 mV, $\overline{\text{DET}}$ is set LOW to indicate that a plug has been inserted.

In case $\overline{\text{DET}}$ is set LOW, when EN is HIGH, J_DET is connected to the current source and the integrated button press detection circuit on J_MIC is active. The button press detection uses a trigger level of 780 mV. It enables a 1.8 V bias voltage in combination with an R_{bias}, matching the series resistance of the microphone, to detect button presses. Not only call-end button press but also forward and reverse button press event levels can be passed from J_MIC to MIC. The codec or processor decodes according to the individual button pressed. Refer to [Figure 3](#) and [Figure 4](#) for details.

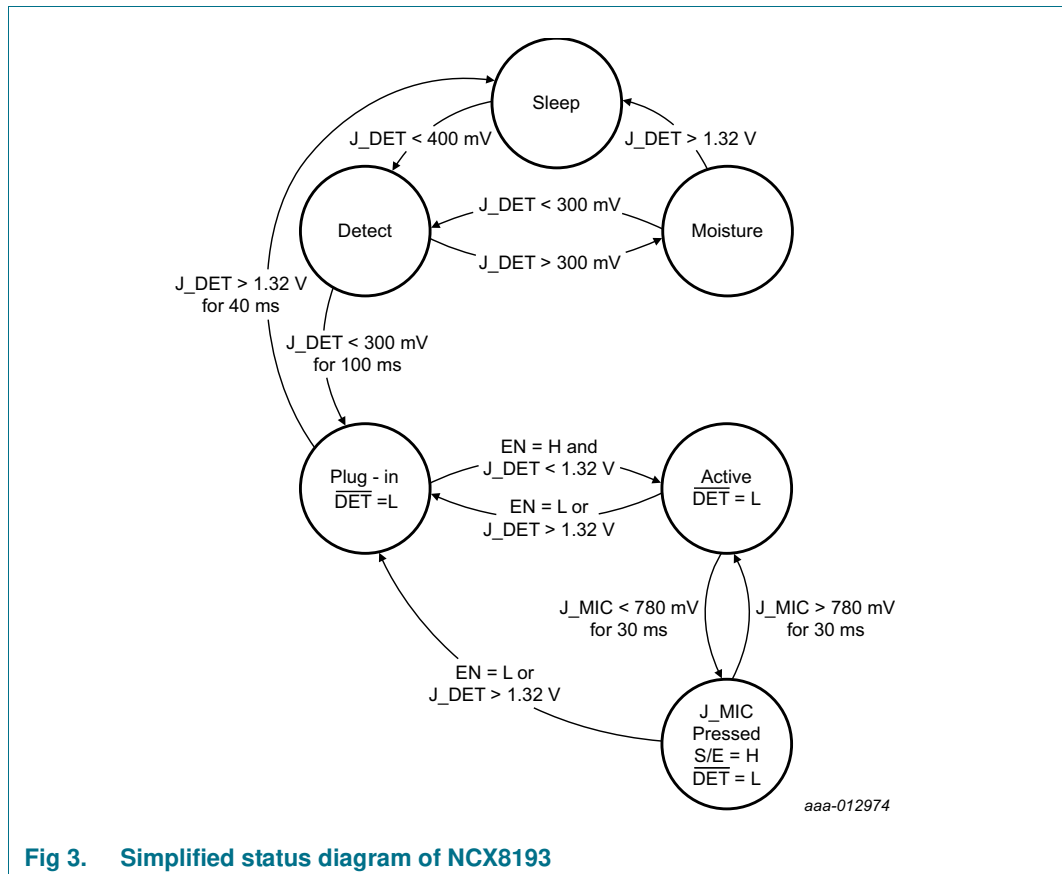

Fig 3. Simplified status diagram of NCX8193

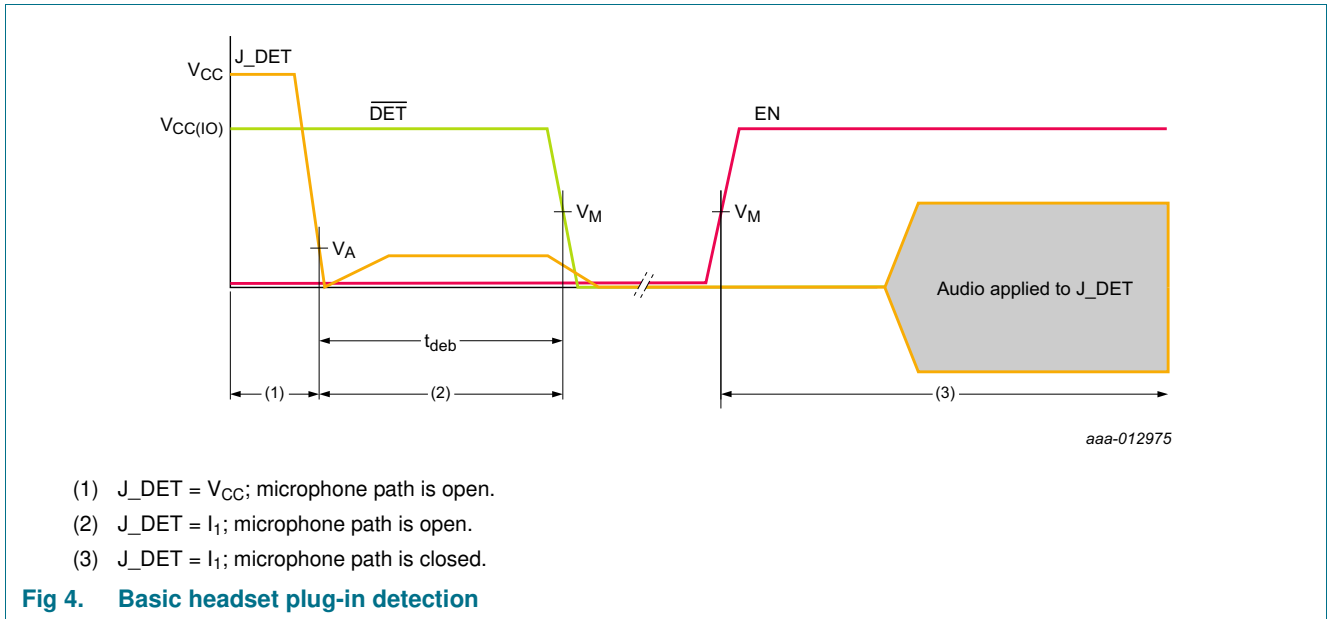

Table 4. Simplified status diagram signal and functional conditions^[1]

		States					
		Sleep	Detect	Moisture	Plug-in	Active	J_MIC pressed
I/O	J_DET	H	L	0.3 V	audio signal	audio signal	audio signal
Input	EN	X	X	X	L	H	H
I/O	J_MIC	L	L	L	L	> 780 mV	< 780 mV
I/O	MIC	Z	Z	Z	Z	J_MIC	J_MIC
Output	$\overline{\text{DET}}$	H ^[2]	H	H	L	L	L
Output	S/E	L	L	L	L	L	H

[1] H = HIGH voltage level; L = LOW voltage level; X = don't care; Z = high-impedance OFF-state.

[2] In case an unplug event is detected, $\overline{\text{DET}}$ remains LOW for 40 ms before returning to HIGH.'

9. Application diagram

For stable operation of the NCX8913, place a 4.7 μF capacitor between V_{CC} and GND and place a 1 μF capacitor between $V_{CC(10)}$ and GND. These bypass capacitors should be placed as close to the device as possible with low-ohmic connections from the power supplies and GND connections.

When the headset or accessory plug is inserted into audio jack, the J_DET pin is shorted to the left (L) audio channel. Audio performance, within the audio range of 20 – 20 kHz, may be affected when connecting external circuitry to the J_DET pin.

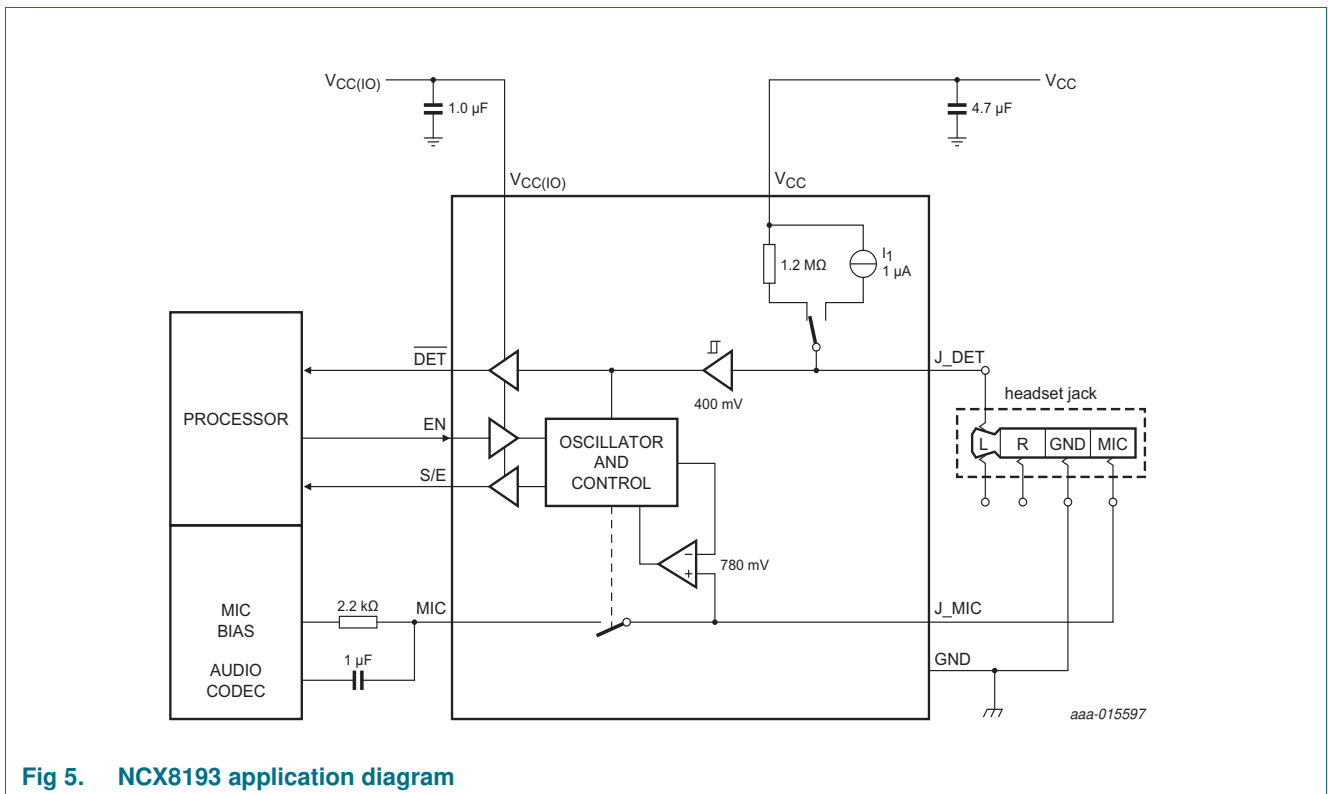

Fig 5. NCX8193 application diagram

10. Limiting values

Table 5. Limiting values

In accordance with the Absolute Maximum Rating System (IEC 60134). Voltages are referenced to GND (ground = 0 V).

Symbol	Parameter	Conditions	Min	Max	Unit
V_{CC}	supply voltage		-0.5	+6.0	V
$V_{CC(10)}$	input/output supply voltage		-0.5	+6.0	V
V_i	input voltage	J_MIC; MIC	-0.5	V_{CC}	V
		EN	-0.5	$V_{CC(10)} + 0.1$	V
		J_DET	-1.5	V_{CC}	V
V_o	output voltage	$\overline{\text{DET}}$; S/E	-0.5	$V_{CC(10)} + 0.3$	V
ΔV	voltage difference	V_{CC} to J_DET	-	6.0	V
I_{sw}	switch current	continuous current from MIC to J_MIC	-	50	mA

Audio jack detection and configuration with false detection prevention

Table 5. Limiting values ...continued

In accordance with the Absolute Maximum Rating System (IEC 60134). Voltages are referenced to GND (ground = 0 V).

Symbol	Parameter	Conditions	Min	Max	Unit
$T_{j(max)}$	maximum junction temperature		-40	+125	°C
T_{stg}	storage temperature		-65	+150	°C
P_{tot}	total power dissipation		-	250	mW

11. Recommended operating conditions

Table 6. Recommended operating conditions

Symbol	Parameter	Conditions	Min	Max	Unit
V_{CC}	supply voltage		2.4	5.25	V
$V_{CC(IO)}$	input/output supply voltage	$V_{CC(IO)} \leq V_{CC}$	1.6	V_{CC}	V
V_I	input voltage	MIC; J_MIC	0	V_{CC}	V
ΔV	voltage difference	V_{CC} to J_DET	-	5.5	V
T_{amb}	ambient temperature		-40	+85	°C

12. Thermal characteristics

Table 7. Thermal characteristics

Symbol	Parameter	Conditions	Typ	Unit
$R_{th(j-a)}$	thermal resistance from junction to ambient		[1] 148	K/W

- [1] $R_{th(j-a)}$ is dependent upon board layout. To minimize $R_{th(j-a)}$, ensure that all pins have a solid connection to larger copper layer areas. In multi-layer PCBs, the second layer should be used to create a large heat spreader area below the device. Avoid using solder-stop varnish under the device.

13. Static characteristics

Table 8. Static characteristics

At recommended operating conditions, unless otherwise specified typical values are measured with $V_{CC} = 3.6$ V and $V_{CC(IO)} = 1.8$ V. Voltages are referenced to GND (ground 0 V).

Symbol	Parameter	Conditions	$T_{amb} = 25$ °C			$T_{amb} = -40$ °C to $+85$ °C		Unit
			Min	Typ	Max	Min	Max	
Digital control								
V_{IH}	HIGH-level input voltage	EN	-	-	-	$0.7V_{CC(IO)}$	-	V
V_{IL}	LOW-level input voltage	EN	-	-	-	-	$0.3V_{CC(IO)}$	V
V_{OH}	HIGH-level output voltage	$\overline{\overline{DET}}$; S/E; $I_O = 0.5$ mA	-	-	-	$0.8V_{CC(IO)}$	-	V
V_{OL}	LOW-level output voltage	$\overline{\overline{DET}}$; S/E; $I_O = 0.5$ mA	-	-	-	-	$0.2V_{CC(IO)}$	V
C_I	input capacitance	J_DET	-	5	-	-	-	pF
		EN	-	1	-	-	-	pF

Audio jack detection and configuration with false detection prevention

Table 8. Static characteristics ...continued

At recommended operating conditions, unless otherwise specified typical values are measured with $V_{CC} = 3.6\text{ V}$ and $V_{CC(IO)} = 1.8\text{ V}$. Voltages are referenced to GND (ground 0 V).

Symbol	Parameter	Conditions	$T_{amb} = 25\text{ °C}$			$T_{amb} = -40\text{ °C to }+85\text{ °C}$		Unit
			Min	Typ	Max	Min	Max	
Microphone bias switch								
$I_{S(OFF)}$	OFF-state leakage current	MIC; $V_{I(MIC)} = 850\text{ mV}$; see Figure 6	-	-	-	-	0.1	μA
R_{ON}	ON resistance	MIC; $I_{O(J_MIC)} = 30\text{ mA}$; $V_{I(MIC)} = 850\text{ mV}$; see Figure 7 and Figure 8						
		$V_{CC} = 2.8\text{ V}$; see Figure 9	-	0.9	-	-	1.5	Ω
		$V_{CC} = 3.0\text{ V}$; see Figure 10	-	0.9	-	-	1.5	Ω
		$V_{CC} = 3.3\text{ V}$; see Figure 11	-	0.9	-	-	1.5	Ω
		$V_{CC} = 3.8\text{ V}$; see Figure 12	-	0.9	-	-	1.5	Ω
$R_{ON(Flat)}$	ON resistance (flatness)	$I_{O(J_MIC)} = 30\text{ mA}$; $0.8\text{ V} < V_{I(MIC)} < 1.2\text{ V}$						
		$V_{CC} = 2.8\text{ V}$; see Figure 9	-	-	-	-	0.6	Ω
		$V_{CC} = 3.0\text{ V}$; see Figure 10	-	-	-	-	0.6	Ω
		$V_{CC} = 3.3\text{ V}$; see Figure 11	-	-	-	-	0.6	Ω
		$V_{CC} = 3.8\text{ V}$; see Figure 12	-	-	-	-	0.6	Ω
$C_{S(OFF)}$	OFF-state capacitance	J_MIC; MIC	-	20	-	-	-	pF
$C_{S(ON)}$	ON-state capacitance	J_MIC; MIC	-	60	-	-	-	pF
Audio/analog performance								
THD	total harmonic distortion	$R_S = R_L = 600\ \Omega$; $V_{AC} = 0.5\text{ V (p-p)}$; $V_{DC} = 1.7\text{ V}$; $f_i = 20\text{ Hz to }20\text{ kHz}$; $V_{CC} = 3.8\text{ V}$; $V_{CC(IO)} = 1.8\text{ V}$; see Figure 13	-	0.01	-	-	-	%
α_{iso}	isolation (OFF-state)	$R_S = R_L = 32\ \Omega$; $V_{AC} = 0.1\text{ V (p-p)}$; $V_{DC} = 2.2\text{ V}$; $f_i = 20\text{ kHz}$; $V_{CC} = 3.8\text{ V}$; $V_{CC(IO)} = 1.8\text{ V}$; see Figure 14	-	-100	-	-	-	dB
PSRR	power supply rejection ratio	$R_S = R_L = 600\ \Omega$; $V_{CC} = 3.8\text{ V}$; $V_{CC(IO)} = 1.8\text{ V}$; $V_{DC} = 1.7\text{ V}$; $V_{AC} = 0.3\text{ V (p-p)}$; $f_i = 217\text{ Hz}$; see Figure 15	-	-110	-	-	-	dB

Audio jack detection and configuration with false detection prevention

Table 8. Static characteristics ...continued

At recommended operating conditions, unless otherwise specified typical values are measured with $V_{CC} = 3.6\text{ V}$ and $V_{CC(10)} = 1.8\text{ V}$. Voltages are referenced to GND (ground 0 V).

Symbol	Parameter	Conditions	$T_{\text{amb}} = 25\text{ °C}$			$T_{\text{amb}} = -40\text{ °C to }+85\text{ °C}$		Unit
			Min	Typ	Max	Min	Max	
Headset detection								
V_{T-}	negative-going threshold voltage	J_DET	-	-	-	-	400	mV
V_{ref}	reference voltage	J_DET; plug detect	-	300	-	270	330	mV
		J_DET; plug removed; $1.6\text{ V} < V_{CC(10)} < V_{CC}$	-	1.32	-	1.2	1.44	V
f_{max}	maximum frequency	J_DET	-	-	-	20000	-	Hz
R_{pu}	pull-up resistance	J_DET	-	1.2	-	0.9	1.6	$\text{M}\Omega$
I_{source}	source current	J_DET	-	1.0	-	-	-	μA
Button press; S/E detect								
V_{ref}	reference voltage	J_MIC	-	780	-	718	842	mV
Current consumption								
I_{CC}	supply current	power down; $V_{CC(10)} = 0\text{ V}$; $V_{CC} = 3.6\text{ V}$; J_DET = open	-	0.1	-	-	1	μA
$I_{\text{CC(tot)}}$	total supply current	$I_{\text{CC(10)}} + I_{\text{CC}}$; $1.6\text{ V} < V_{CC(10)} < 2.0\text{ V}$; $V_{CC} = 3.6\text{ V}$;						
		Sleep mode; J_DET = open	-	0.1	-	-	1	μA
		Plug-in mode	-	15	-	-	25	μA
		Active mode	-	15	-	-	25	μA

13.1 Test circuits and graphs

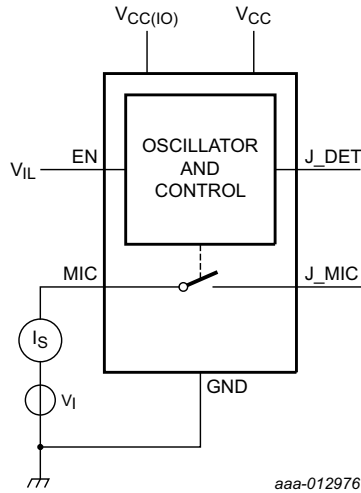

aaa-012976

Fig 6. Test circuit for measuring OFF-state leakage current

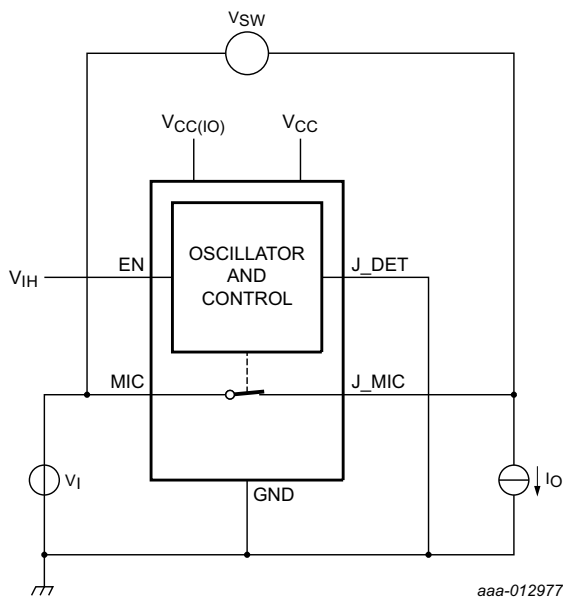

aaa-012977

$R_{ON} = V_{SW} / I_o$

Fig 7. Test circuit for measuring ON resistance

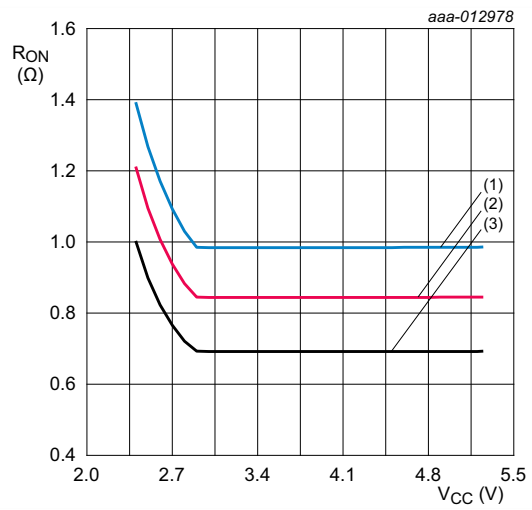

aaa-012978

- (1) $T_{amb} = 85\text{ °C}$
- (2) $T_{amb} = 25\text{ °C}$
- (3) $T_{amb} = -40\text{ °C}$

Fig 8. ON resistance versus VCC

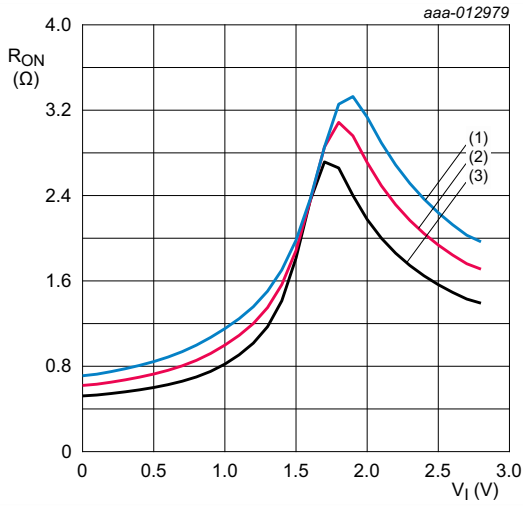

- (1) $T_{amb} = 85$ °C
- (2) $T_{amb} = 25$ °C
- (3) $T_{amb} = -40$ °C

Fig 9. ON resistance as a function of $V_{I(MIC)}$; $V_{CC} = 2.8$ V

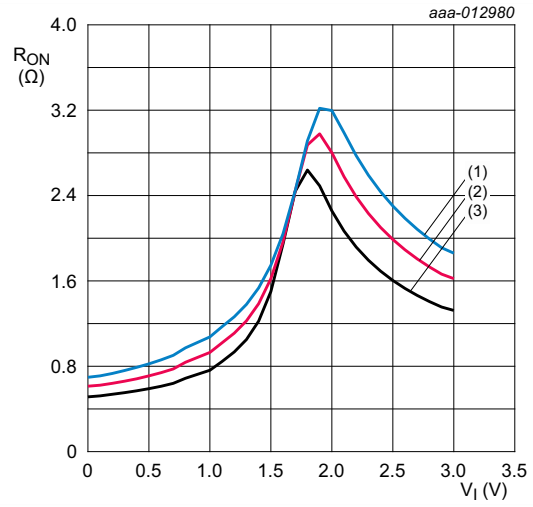

- (1) $T_{amb} = 85$ °C
- (2) $T_{amb} = 25$ °C
- (3) $T_{amb} = -40$ °C

Fig 10. ON resistance as a function of $V_{I(MIC)}$; $V_{CC} = 3.0$ V

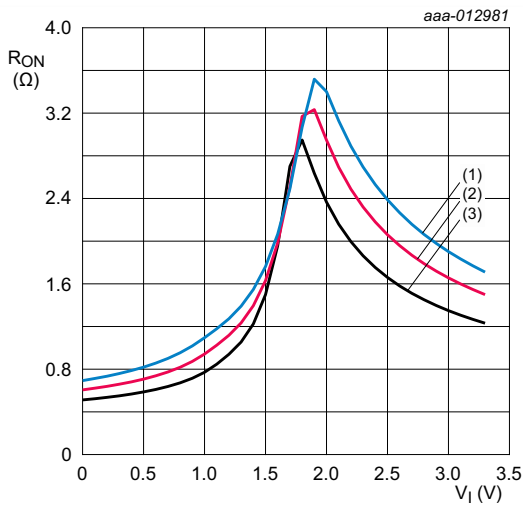

- (1) $T_{amb} = 85$ °C
- (2) $T_{amb} = 25$ °C
- (3) $T_{amb} = -40$ °C

Fig 11. ON resistance as a function of $V_{I(MIC)}$; $V_{CC} = 3.3$ V

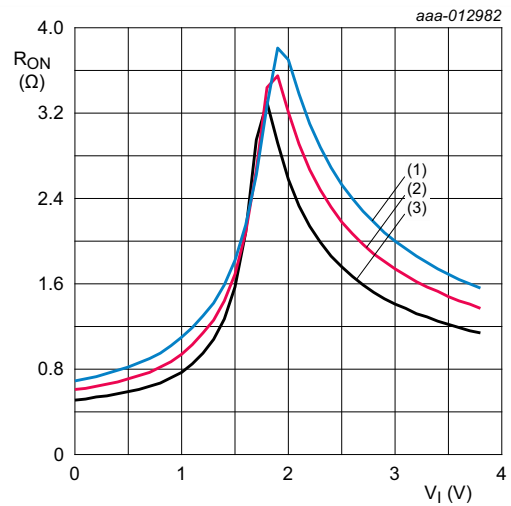

- (1) $T_{amb} = 85$ °C
- (2) $T_{amb} = 25$ °C
- (3) $T_{amb} = -40$ °C

Fig 12. ON resistance as a function of $V_{I(MIC)}$; $V_{CC} = 3.8$ V

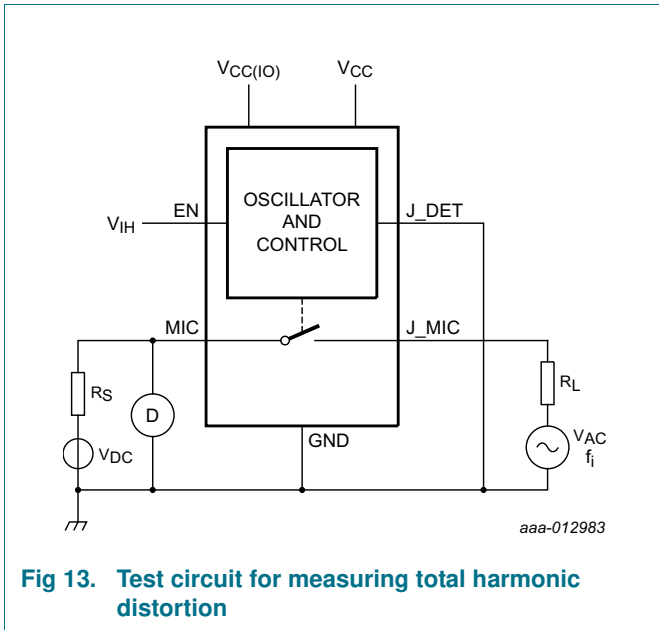

Fig 13. Test circuit for measuring total harmonic distortion

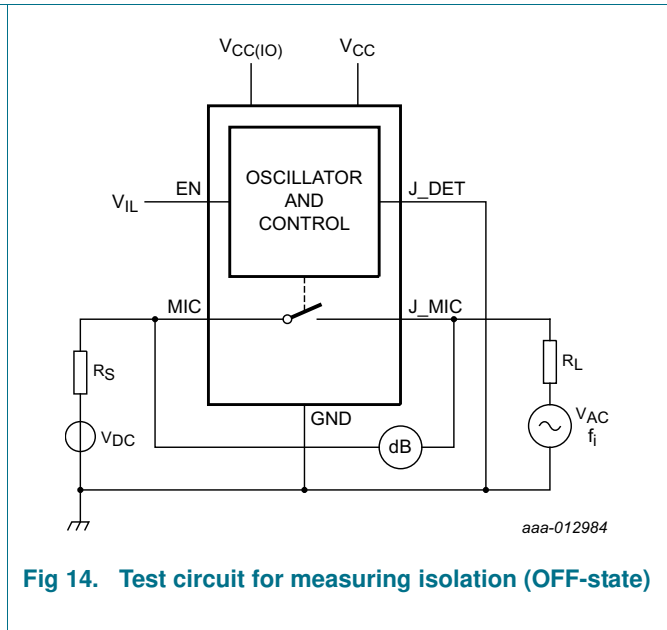

Fig 14. Test circuit for measuring isolation (OFF-state)

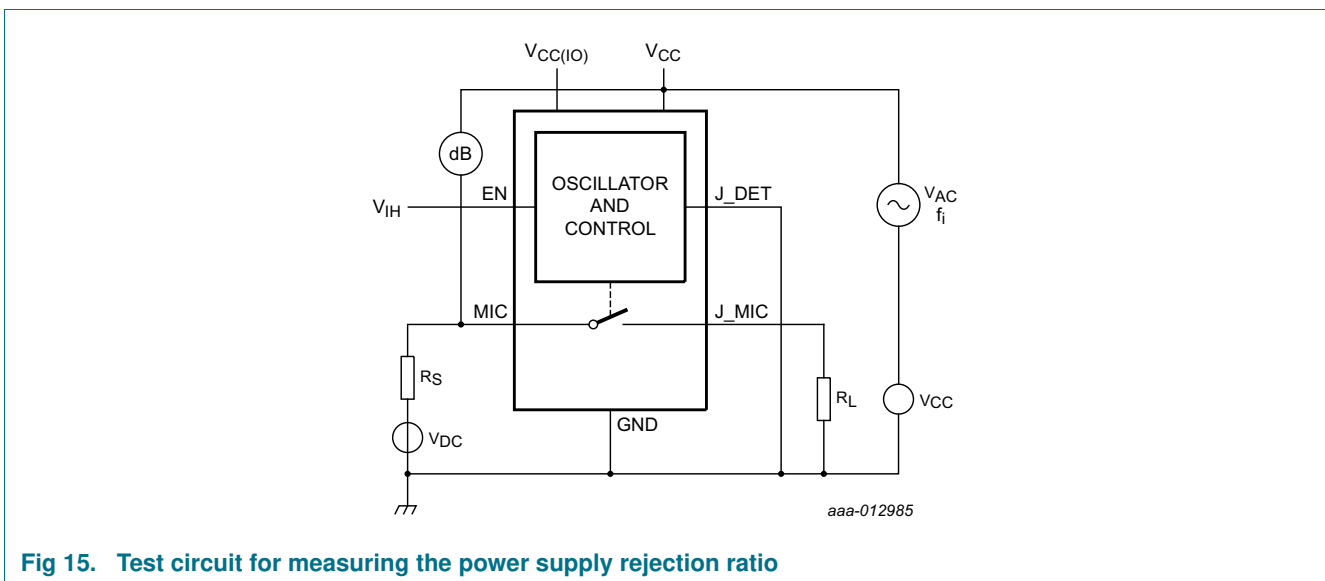

Fig 15. Test circuit for measuring the power supply rejection ratio

14. Dynamic characteristics

Table 9. Dynamic characteristics

At recommended operating conditions; unless otherwise specified typical values are measured with $V_{CC} = 3.6\text{ V}$ and $V_{CC(IO)} = 1.8\text{ V}$; voltages are referenced to GND (ground = 0 V); see [Figure 19](#).

Symbol	Parameter	Conditions	$T_{amb} = 25\text{ °C}$			$T_{amb} = -40\text{ °C to }+85\text{ °C}$		Unit
			Min	Typ	Max	Min	Max	
t_{TLH}	LOW to HIGH output transition time	\overline{DET} ; S/E; $C_L = 5\text{ pF}$; see Figure 16 and Figure 19	-	5	-	-	-	ns
t_{THL}	HIGH to LOW output transition time	\overline{DET} ; S/E; $C_L = 5\text{ pF}$; see Figure 16 and Figure 19	-	2	-	-	-	ns
t_{deb}	debounce time	see Figure 16 and Figure 19						
		Detect to Plug-in	-	80	-	-	100	ms
		Plug-in to Sleep	-	40	-	-	-	ms
	Active to or from J_MIC Pressed	-	30	-	-	-	ms	
t_{en}	enable time	EN to J_MIC; $V_{I(MIC)} = V_{CC}$; see Figure 17 and Figure 20	-	15	-	-	-	μs
t_{dis}	disable time	$V_{I(MIC)} = V_{CC}$;						
		EN to J_MIC; see Figure 17 and Figure 20	-	15	-	-	-	μs
		J_DET to J_MIC; see Figure 18	-	15	-	-	-	μs

14.1 Waveform and test circuits

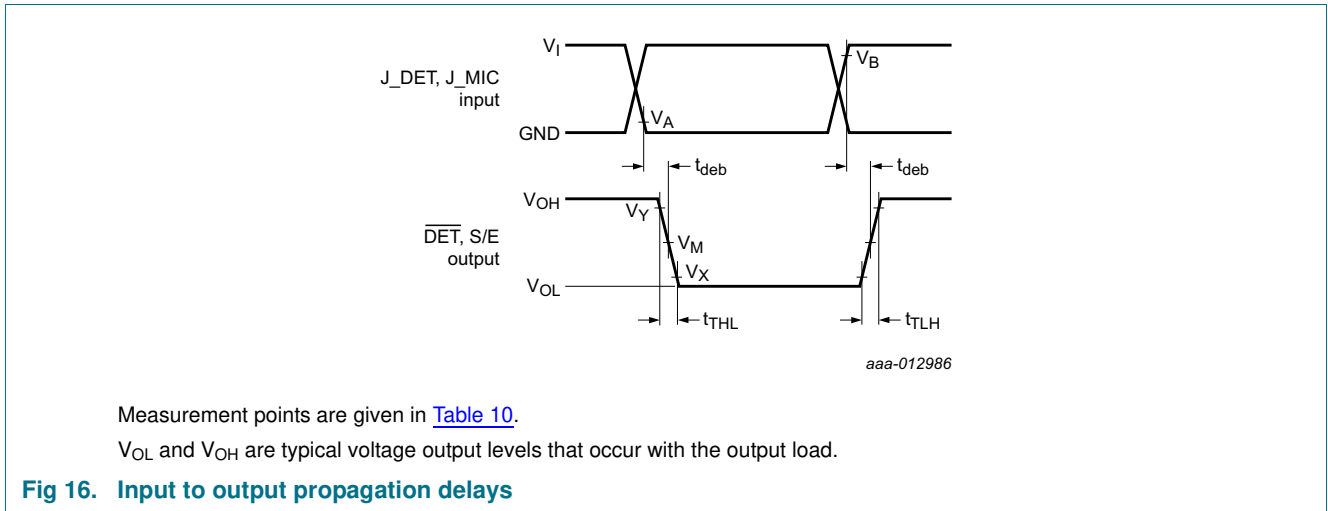
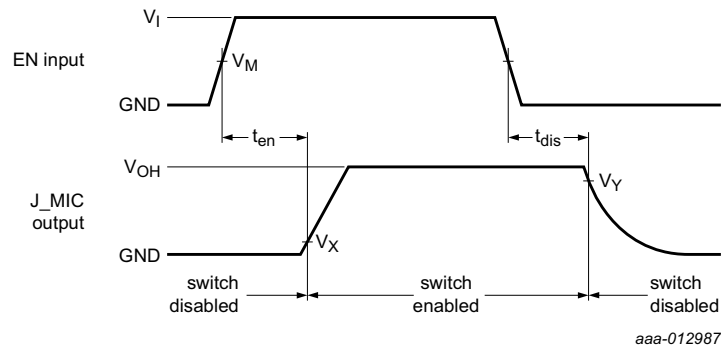

Table 10. Measurement points

Supply voltage		Input J_DET		Input J_MIC		Output DET, S/E		
V_{CC}	$V_{CC(IO)}$	V_A	V_B	V_A	V_B	V_M	V_X	V_Y
3.6 V	1.8 V	0.05 V	1.44 V	0.7 V	0.85 V	$0.5V_{CC(IO)}$	$0.2V_{CC(IO)}$	$0.8V_{CC(IO)}$

Audio jack detection and configuration with false detection prevention



Measurement points are given in [Table 11](#).
 Logic level: V_{OH} is the typical output voltage that occurs with the output load.

Fig 17. Enable and disable times (EN to J_MIC)

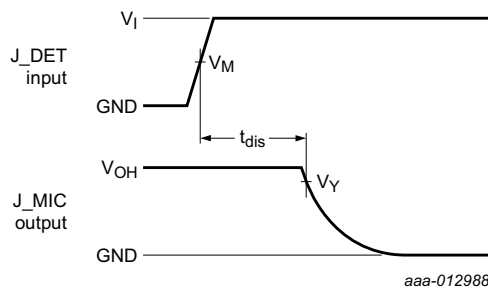

Measurement points are given in [Table 11](#).
 Logic level: V_{OH} is the typical output voltage that occurs with the output load.

Fig 18. Enable and disable times (J_DET to J_MIC)

Table 11. Measurement points

Supply Voltage		Input J_DET	Input EN	Output J_MIC	
V_{CC}	$V_{CC(10)}$	V_M	V_M	V_X	V_Y
3.6 V	1.8 V	1.44 V	$0.5V_{CC(10)}$	$0.1V_{CC}$	$0.9V_{CC}$

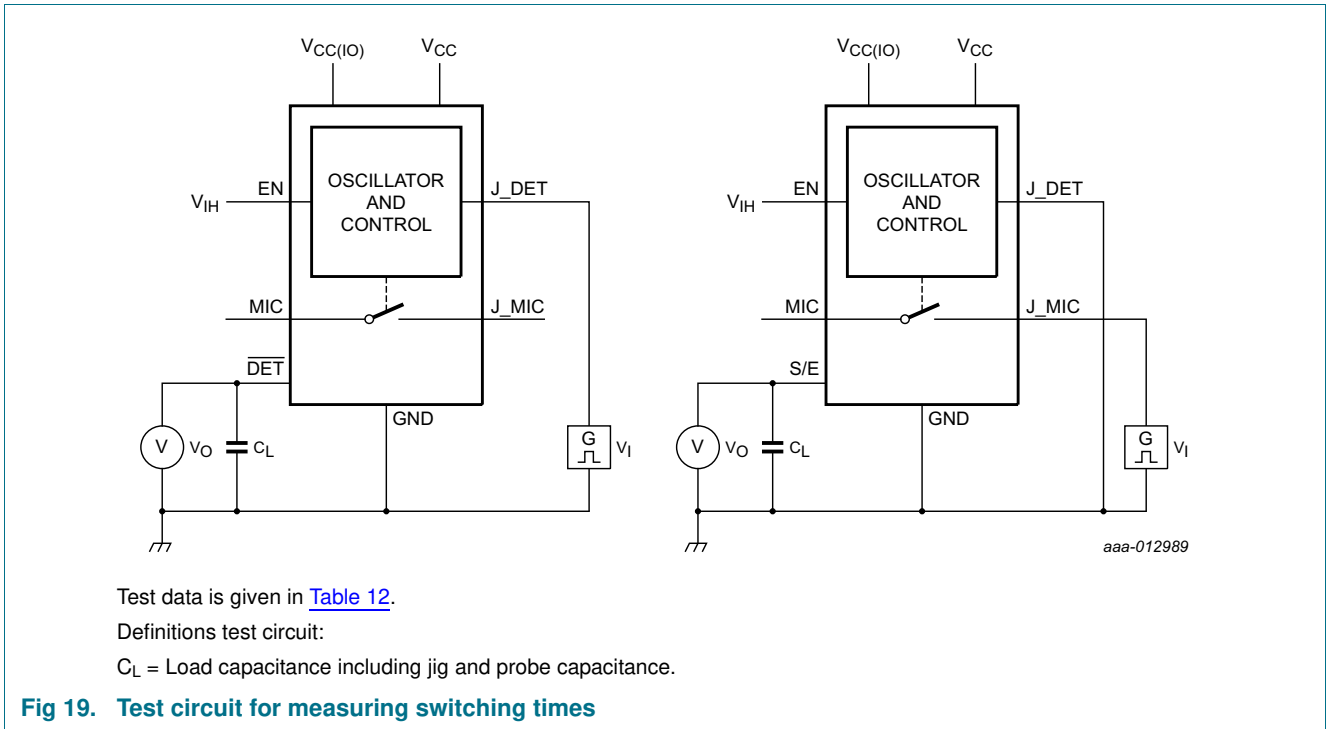

Table 12. Test data

Supply voltage		Input		Load
V_{CC}	$V_{CC(10)}$	V_I	t_r, t_f	C_L
2.4 V to 5.25 V	1.6 V to V_{CC}	V_{CC}	≤ 2.5 ns	5 pF

Audio jack detection and configuration with false detection prevention

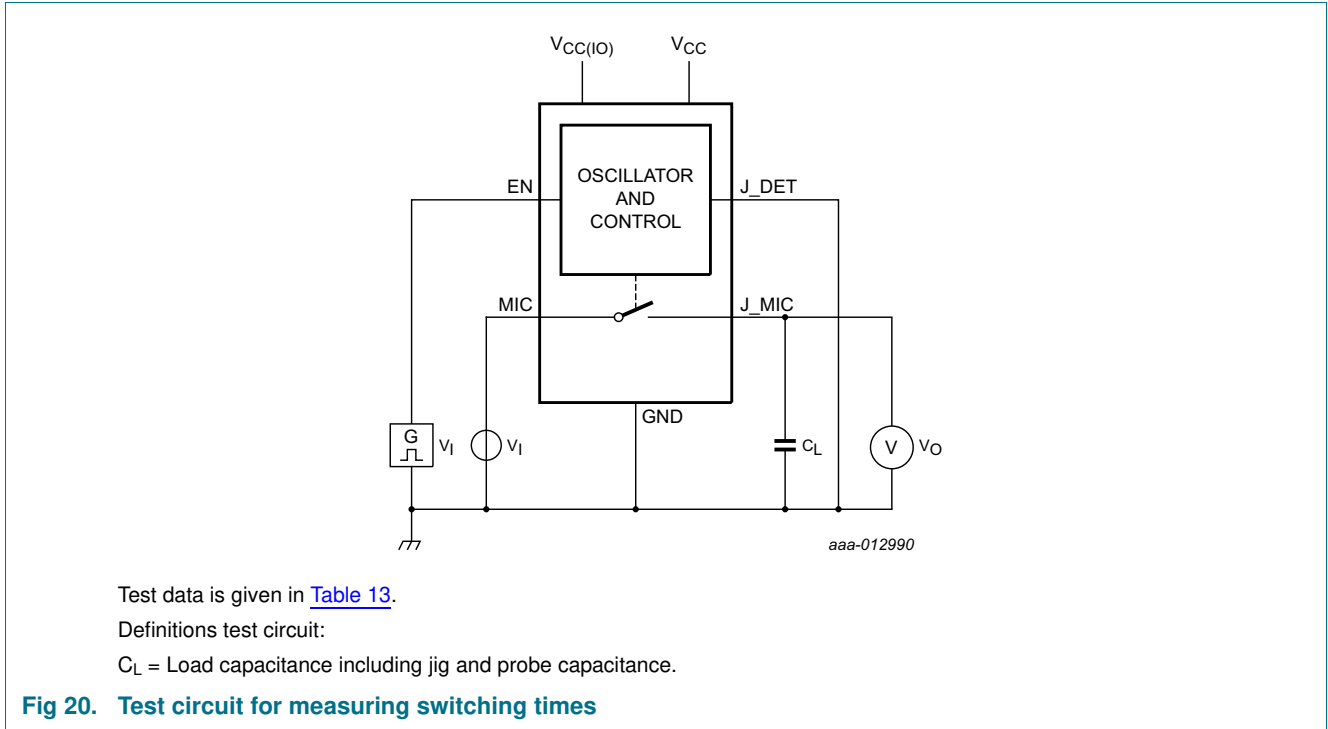

Table 13. Test data

Supply voltage		Input			Load
V_{CC}	$V_{CC(10)}$	$V_{I(EN)}$	$V_{I(J_MIC)}$	t_r, t_f	C_L
2.4 V to 5.25 V	1.6 V to V_{CC}	$V_{CC(10)}$	V_{CC}	≤ 2.5 ns	5 pF

15. Package outline

XQFN10: plastic, extremely thin quad flat package; no leads; 10 terminals; body 1.8 x 1.4 x 0.5 mm

SOT1160-2

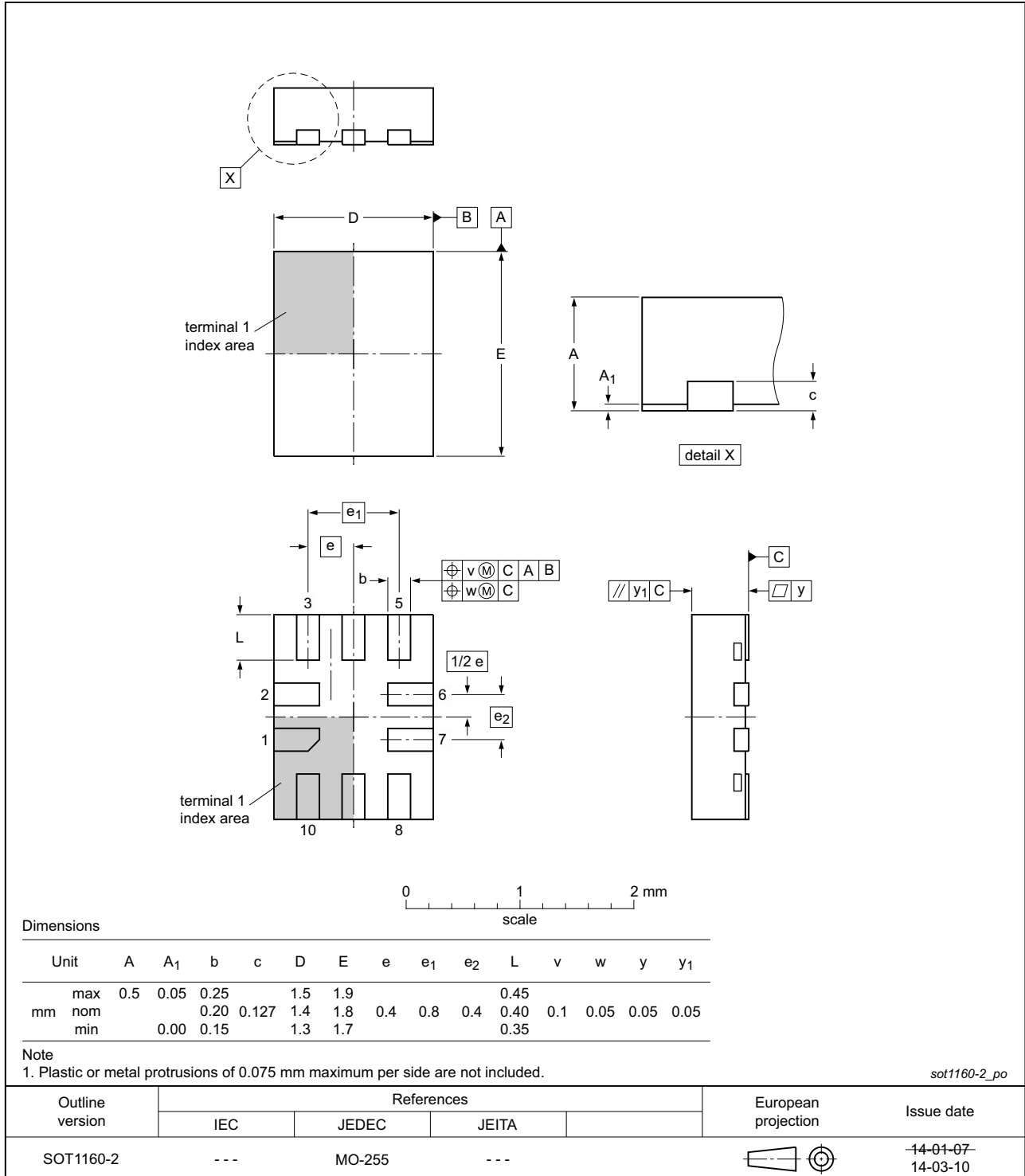

Fig 21. Package outline XQFN10 (SOT1160-2) package

16. Abbreviations

Table 14. Abbreviations

Acronym	Description
CDM	Charged Device Model
DUT	Device Under Test
ESD	ElectroStatic Discharge
HBM	Human Body Model
MOSFET	Metal-Oxide Semiconductor Field Effect Transistor
THD	Total Harmonic Distortion

17. Revision history

Table 15. Revision history

Document ID	Release date	Data sheet status	Change notice	Supersedes
NCX8193 v.2	20141121	Product data sheet	-	NCX8193 v.1
Modifications:	• Added application			
NCX8193 v.1	20140709	Product data sheet	-	-

18. Legal information

18.1 Data sheet status

Document status ^{[1][2]}	Product status ^[3]	Definition
Objective [short] data sheet	Development	This document contains data from the objective specification for product development.
Preliminary [short] data sheet	Qualification	This document contains data from the preliminary specification.
Product [short] data sheet	Production	This document contains the product specification.

[1] Please consult the most recently issued document before initiating or completing a design.

[2] The term 'short data sheet' is explained in section "Definitions".

[3] The product status of device(s) described in this document may have changed since this document was published and may differ in case of multiple devices. The latest product status information is available on the Internet at URL <http://www.nxp.com>.

18.2 Definitions

Draft — The document is a draft version only. The content is still under internal review and subject to formal approval, which may result in modifications or additions. NXP Semiconductors does not give any representations or warranties as to the accuracy or completeness of information included herein and shall have no liability for the consequences of use of such information.

Short data sheet — A short data sheet is an extract from a full data sheet with the same product type number(s) and title. A short data sheet is intended for quick reference only and should not be relied upon to contain detailed and full information. For detailed and full information see the relevant full data sheet, which is available on request via the local NXP Semiconductors sales office. In case of any inconsistency or conflict with the short data sheet, the full data sheet shall prevail.

Product specification — The information and data provided in a Product data sheet shall define the specification of the product as agreed between NXP Semiconductors and its customer, unless NXP Semiconductors and customer have explicitly agreed otherwise in writing. In no event however, shall an agreement be valid in which the NXP Semiconductors product is deemed to offer functions and qualities beyond those described in the Product data sheet.

18.3 Disclaimers

Limited warranty and liability — Information in this document is believed to be accurate and reliable. However, NXP Semiconductors does not give any representations or warranties, expressed or implied, as to the accuracy or completeness of such information and shall have no liability for the consequences of use of such information. NXP Semiconductors takes no responsibility for the content in this document if provided by an information source outside of NXP Semiconductors.

In no event shall NXP Semiconductors be liable for any indirect, incidental, punitive, special or consequential damages (including - without limitation - lost profits, lost savings, business interruption, costs related to the removal or replacement of any products or rework charges) whether or not such damages are based on tort (including negligence), warranty, breach of contract or any other legal theory.

Notwithstanding any damages that customer might incur for any reason whatsoever, NXP Semiconductors' aggregate and cumulative liability towards customer for the products described herein shall be limited in accordance with the *Terms and conditions of commercial sale* of NXP Semiconductors.

Right to make changes — NXP Semiconductors reserves the right to make changes to information published in this document, including without limitation specifications and product descriptions, at any time and without notice. This document supersedes and replaces all information supplied prior to the publication hereof.

Suitability for use — NXP Semiconductors products are not designed, authorized or warranted to be suitable for use in life support, life-critical or safety-critical systems or equipment, nor in applications where failure or malfunction of an NXP Semiconductors product can reasonably be expected to result in personal injury, death or severe property or environmental damage. NXP Semiconductors and its suppliers accept no liability for inclusion and/or use of NXP Semiconductors products in such equipment or applications and therefore such inclusion and/or use is at the customer's own risk.

Applications — Applications that are described herein for any of these products are for illustrative purposes only. NXP Semiconductors makes no representation or warranty that such applications will be suitable for the specified use without further testing or modification.

Customers are responsible for the design and operation of their applications and products using NXP Semiconductors products, and NXP Semiconductors accepts no liability for any assistance with applications or customer product design. It is customer's sole responsibility to determine whether the NXP Semiconductors product is suitable and fit for the customer's applications and products planned, as well as for the planned application and use of customer's third party customer(s). Customers should provide appropriate design and operating safeguards to minimize the risks associated with their applications and products.

NXP Semiconductors does not accept any liability related to any default, damage, costs or problem which is based on any weakness or default in the customer's applications or products, or the application or use by customer's third party customer(s). Customer is responsible for doing all necessary testing for the customer's applications and products using NXP Semiconductors products in order to avoid a default of the applications and the products or of the application or use by customer's third party customer(s). NXP does not accept any liability in this respect.

Limiting values — Stress above one or more limiting values (as defined in the Absolute Maximum Ratings System of IEC 60134) will cause permanent damage to the device. Limiting values are stress ratings only and (proper) operation of the device at these or any other conditions above those given in the Recommended operating conditions section (if present) or the Characteristics sections of this document is not warranted. Constant or repeated exposure to limiting values will permanently and irreversibly affect the quality and reliability of the device.

Terms and conditions of commercial sale — NXP Semiconductors products are sold subject to the general terms and conditions of commercial sale, as published at <http://www.nxp.com/profile/terms>, unless otherwise agreed in a valid written individual agreement. In case an individual agreement is concluded only the terms and conditions of the respective agreement shall apply. NXP Semiconductors hereby expressly objects to applying the customer's general terms and conditions with regard to the purchase of NXP Semiconductors products by customer.

No offer to sell or license — Nothing in this document may be interpreted or construed as an offer to sell products that is open for acceptance or the grant, conveyance or implication of any license under any copyrights, patents or other industrial or intellectual property rights.

Audio jack detection and configuration with false detection prevention

Export control — This document as well as the item(s) described herein may be subject to export control regulations. Export might require a prior authorization from competent authorities.

Non-automotive qualified products — Unless this data sheet expressly states that this specific NXP Semiconductors product is automotive qualified, the product is not suitable for automotive use. It is neither qualified nor tested in accordance with automotive testing or application requirements. NXP Semiconductors accepts no liability for inclusion and/or use of non-automotive qualified products in automotive equipment or applications.

In the event that customer uses the product for design-in and use in automotive applications to automotive specifications and standards, customer (a) shall use the product without NXP Semiconductors' warranty of the product for such automotive applications, use and specifications, and (b) whenever customer uses the product for automotive applications beyond

NXP Semiconductors' specifications such use shall be solely at customer's own risk, and (c) customer fully indemnifies NXP Semiconductors for any liability, damages or failed product claims resulting from customer design and use of the product for automotive applications beyond NXP Semiconductors' standard warranty and NXP Semiconductors' product specifications.

Translations — A non-English (translated) version of a document is for reference only. The English version shall prevail in case of any discrepancy between the translated and English versions.

18.4 Trademarks

Notice: All referenced brands, product names, service names and trademarks are the property of their respective owners.

19. Contact information

For more information, please visit: <http://www.nxp.com>

For sales office addresses, please send an email to: salesaddresses@nxp.com

20. Contents

1	General description	1
2	Features and benefits	1
3	Applications	1
4	Ordering information	1
5	Marking	1
6	Functional diagram	2
7	Pinning information	3
7.1	Pinning	3
7.2	Pin description	3
8	Functional description	4
9	Application diagram	6
10	Limiting values	6
11	Recommended operating conditions	7
12	Thermal characteristics	7
13	Static characteristics	7
13.1	Test circuits and graphs	10
14	Dynamic characteristics	13
14.1	Waveform and test circuits	13
15	Package outline	17
16	Abbreviations	18
17	Revision history	18
18	Legal information	19
18.1	Data sheet status	19
18.2	Definitions	19
18.3	Disclaimers	19
18.4	Trademarks	20
19	Contact information	20
20	Contents	21

Please be aware that important notices concerning this document and the product(s) described herein, have been included in section 'Legal information'.

© NXP Semiconductors N.V. 2014.

All rights reserved.

For more information, please visit: <http://www.nxp.com>

For sales office addresses, please send an email to: salesaddresses@nxp.com

Date of release: 21 November 2014

Document identifier: NCX8193